



# ***AP5C***

**User's Guide**

# Copyright

---

Copyright © 1995 by this company. All rights reserved. No part of this publication may be reproduced, transmitted, transcribed, stored in a retrieval system, or translated into any language or computer language, in any form or by any means, electronic, mechanical, magnetic, optical, manual or otherwise, without the prior written permission of this company.

# Disclaimer

---

This company makes no representations or warranties, either expressed or implied, with respect to the contents hereof and specifically disclaims any warranties, merchantability or fitness for any particular purpose. Any software described in this manual is sold or licensed "as is". Should the programs prove defective following their purchase, the buyer (and not this company, its distributor, or its dealer) assumes the entire cost of all necessary servicing, repair, and any incidental or consequential damages resulting from any defect in the software. Further, this company reserves the right to revise this publication and to make changes from time to time in the contents hereof without obligation to notify any person of such revision or changes.

AMI is a registered trademark of American Megatrends Inc.  
Pentium is a registered trademark of Intel Corporation.  
PC XT/AT is a registered trademark of International Business Machines Corporation.

Other brand and product names are trademarks and/or registered trademarks of their respective holders.

# FCC Statement

---

## FCC Class B Radio Frequency Interference Statement

**Note:**

This equipment has been tested and found to comply with the limits for a Class B digital device, pursuant to Part 15 of FCC Rules. These limits are designed to provide reasonable protection against harmful interference in a residential installation. This equipment generates, uses, and can radiate radio frequency energy and, if not installed and used in accordance with the instructions, may cause harmful interference to radio communications. However, there is no guarantee that interference will not occur in a particular installation. If this equipment does cause harmful interference to radio or television reception, which can be determined by turning the equipment off and on, the user is encouraged to try to correct the interference by one or more of the following measures:

1. Reorient or relocate the receiving antenna.
2. Increase the separation between the equipment and receiver.
3. Connect the equipment into an outlet on a circuit different from that to which the receiver is connected.
4. Consult the dealer or an experienced radio/television technician for help.

**Notice 1:**

The changes or modifications not expressly approved by the party responsible for compliance could void the user's authority to operate the equipment.

**Notice 2:**

Shielded interface cables, if any, must be used in order to comply with emission limits.

# About this Manual

---

## ***Purpose and Scope***

This manual tells how to install and configure the system board.

## ***Organization***

This manual consists of three chapters and one appendix.

Chapter 1, **Features**, covers the specifications, layout and components of the system board.

Chapter 2, **Hardware Setup**, tells how to set the jumpers, upgrade the CPU and the system memory, install the system board and add expansion cards.

Chapter 3, **AMI BIOS**, explains the system BIOS and tells how to configure the system by setting the BIOS parameters.

Appendix A, **Jumper Summary**, gives you a tabular summary of the jumper settings discussed in Chapter 2. It also gives a list of the onboard connectors.

# About this Manual

---

## Conventions

The following conventions are used in this manual:

Text entered by user,  
default settings

message displayed

a, e, s, etc



Represent text input by the user, default  
settings and recommended selections

Denotes actual messages that appear  
on screen

Represent the actual keys that you  
have to press on the keyboard.

### NOTE

Gives bits and pieces of additional  
information related to the current topic.

### WARNING

Alerts you to any damage that might  
result from doing or not doing specific  
actions.

### CAUTION

Suggests precautionary measures to  
avoid potential hardware or software  
problems.

### IMPORTANT

Reminds you to take specific action  
relevant to the accomplishment of the  
procedure at hand.

### TIP

Tells how to accomplish a procedure  
with minimum steps through little  
shortcuts.

# Table of Contents

---

## 1 Features

Specifications .....	1-2
Board Layout.....	1-3
System Board Parts .....	1-4
Microprocessor.....	1-4
ASICs .....	1-4
AMI BIOS .....	1-4
Expansion Slots.....	1-5
DRAM Sockets .....	1-5
Two-Channel PCI Mode 4 Enhanced IDE	1-5
Super I/O Controller.....	1-6
Keyboard Connector.....	1-6
SRAM .....	1-6
Power Management .....	1-6

## 2 Hardware Setup

ESD Precautions.....	2-1
Installing a Microprocessor .....	2-2
Upgrading the Microprocessor .....	2-4
Jumper Settings .....	2-4
Selecting the CPU Type .....	2-6
Selecting the SRAM Type (Optional).....	2-7
Setting the Cache Size .....	2-7

## Table of Contents

---

Selecting the Flash ROM Type.....	2-9
Clearing the CMOS .....	2-10
Enabling the PS/2 Mouse (Optional) .....	2-10
Enabling the Onboard Super I/O Controller.....	2-11
Selecting the ECP DMA Channel .....	2-11
Memory Configuration.....	2-12
Installing a SIMM.....	2-14
Removing a SIMM.....	2-15
Connectors.....	2-16
Multifunction Connector.....	2-16
Break Switch .....	2-18
Keyboard Connector.....	2-18
Power Connector.....	2-19
Fan Connectors.....	2-20
Installation.....	2-21
Installing the System Board.....	2-21
Installing Expansion Boards .....	2-22



# Table of Contents

---

## 3 AMI BIOS

AMI BIOS Setup Main Menu .....	3-1
Standard CMOS Setup .....	3-2
Date/Time .....	3-2
Floppy Drives A and B .....	3-3
Hard Disk Drives .....	3-4
Advanced CMOS Setup .....	3-5
Typematic Rate (Chars./Sec.) .....	3-6
System Keyboard .....	3-7
Primary Display .....	3-7
PS/2 Mouse Support .....	3-7
Above 1 MB Memory Test .....	3-7
Memory Test Tick Sound .....	3-7
Hit "Del" Message Display .....	3-8
Extended BIOS RAM Area .....	3-8
Wait for F1 If Any Error .....	3-8
System Boot-up Num Lock .....	3-8
Floppy Drive Seek at Boot .....	3-9
Floppy Drive Swapping .....	3-9
System Boot-up Sequence .....	3-9
Password Checking .....	3-9
Cache Memory .....	3-10
System BIOS Shadow Cacheable .....	3-10

## Table of Contents

---

Adapter ROM Control .....	3-10
IDE Control .....	3-11
Secondary Drives Present .....	3-13
Chipset Setup Mode .....	3-13
Chipset Features Setup .....	3-14
SRAM Type* .....	3-17
DRAM Control .....	3-17
ISA Control .....	3-19
PCI Control .....	3-20
IRQ Allocated .....	3-21
Power Management Setup .....	3-22
Advanced Power Management .....	3-23
Full-on to Standby Timeout .....	3-23
Standby to Suspend Timeout .....	3-23
IDE Drive Power Down in .....	3-24
Video Power Down in .....	3-24
VGA Power Down Mode .....	3-24
Slow Clock Ratio .....	3-24
Break Event (IRQ 3~7, 9~15) .....	3-24
Peripheral Setup .....	3-25
Programming Mode .....	3-25
Onboard FDC .....	3-26
Serial Port 1 .....	3-26

# Table of Contents

---

Serial Port 2.....	3-26
Parallel Port.....	3-26
IRQ Active .....	3-26
Parallel Port Mode .....	3-26
Utility Setup.....	3-27
IDE Setup .....	3-27
Color Set .....	3-28
Default Setup .....	3-28
Original .....	3-28
Optimal .....	3-29
Fail-safe.....	3-29
Security Setup.....	3-30
Password.....	3-30
Anti-virus .....	3-32
Exit Setup.....	3-33
NCR SCSI BIOS and Drivers .....	3-34

## **Appendix A      Jumper Summary**

# **Features 1**

---

The AP5C is a Pentium™ -based system board that utilizes the PCI/ISA architecture. It has three PCI slots, three ISA-AT slots and one PCI-/ISA-shared slot. The board integrates the Intel Triton 82437FX, 82438FX and 82371FB application-specific integrated circuit (ASIC) chipsets that enable the System Management Mode (SMM) function of the Pentium chip. It also features the Green power management that extends energy conservation from system components to display monitor.

The system memory is expandable to 128 MB by adding single in-line memory modules (SIMMs). The second-level cache is also upgradable to 512 KB and supports the write-back mode.

A super I/O controller and a PCI mode 4 enhanced-IDE controller with bus master support are also incorporated in the design to further enhance system performance. The board measures 220 mm x 330 mm (full baby-AT size).

# Features

---

## Specifications

<b>Microprocessor</b>	Pentium™ (3.3V) Processor 75/90/100/120/133/150/166 MHz
<b>Memory</b>	128 MB
<b>SIMM Sockets</b>	Six 72-pin, 32-bit
<b>ASICs</b>	Intel Triton 82437FX Intel Triton 82438FX Intel Triton 82371FB
<b>I/O Chip</b>	SMC FDC37C665GT
<b>Bus Architecture</b>	PCI, ISA
<b>Expansion Slots</b>	Three PCI slots Three ISA-AT slots One PCI-/ISA-shared slot
<b>Ports</b>	One parallel port (SPP/ECP/EPP) Two serial ports (UART 16C550) Two-channel PCI mode 4 enhanced IDE One floppy disk controller port
<b>Secondary Cache</b>	256 KB/512 KB
<b>BIOS</b>	AMI Plug-and-Play WinBIOS
<b>RTC</b>	Dallas DS12887A
<b>Board Size</b>	220 mm x 330 mm (full baby-AT)

# Features

## Board Layout

1. Keyboard controller
2. SMC37C665GT I/O chip
3. PS/2 mouse connector
4. Keyboard connector
5. Power connector
6. Parallel connector
7. COM 1 connector
8. COM 2 connector
9. FDC connector
10. IDE 2 connector
11. IDE 1 connector
12. 72-pin SIMM sockets
13. 82438 ASIC chip
14. Voltage regulator
15. Second-level cache
16. 4-pin fan connector
17. 2-pin fan connector
18. HDD LED connector
19. Multifunction connector
20. ZIF-type CPU socket
21. Battery/RTC
22. 82437 ASIC chip
23. TAG RAM
24. System BIOS
25. 82371 ASIC chip
26. ISA slots
27. PCI slots

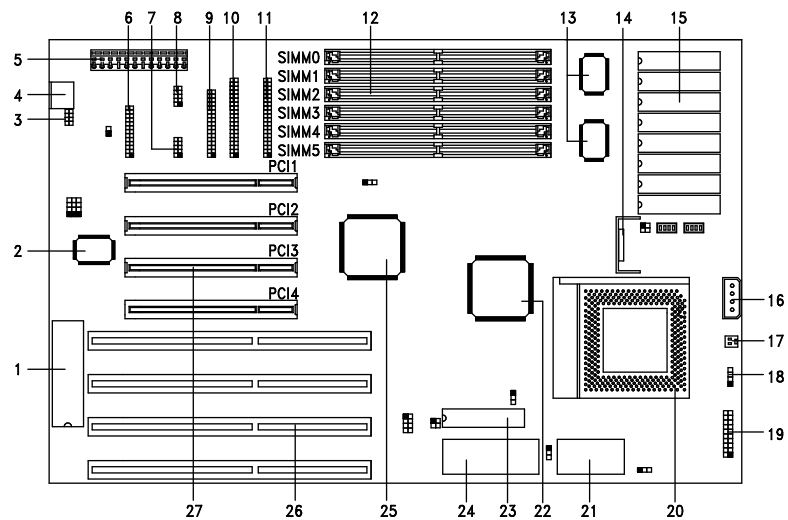

# Features

---

## System Board Parts

### *Microprocessor*

The AP5C system board uses an Intel Pentium (3.3V) processor running at speeds of 75, 90, 100, 120, 133, 150 or 166 MHz. Chapter 2 gives details on how to upgrade the Pentium processor.

### *ASICs*

The ASICs onboard are the 82437FX, 82438FX and 82371FB. The 82437 serves as the system memory controller and PCI bus interface.

The two 82438FX ASICs function as PCI local-bus data paths that offer 64-bit DRAM and 32-bit PCI bus interfaces to support the 64-bit Pentium processor data bus.

The 82371FB acts as the PCI-/ISA-bus bridge that translates the PCI bus cycles into ISA bus cycles or vice-versa. It also functions as the PCI fast-IDE interface and the SMM controller.

### *AMI BIOS*

The AMI BIOS (basic input-output system) resides in the flash ROM chip. This contains the program that performs the power-on self-tests (POST) upon booting. During POST, this program activates the peripheral devices, tests onboard memory, and prepares the system for operation. Chapter 3 gives more information on the AMI BIOS.

# Features

---

## ***Expansion Slots***

The board expansion slots consist of three PCI slots, three ISA-AT slots and one PCI-/ISA-shared slot. These expansion slots are the parallel bars on the system board. There are rows of golden pins inside each slot that serve as a clutch to secure the contacts of expansion boards. Chapter 2 tells how to install expansion boards.

## ***DRAM Sockets***

The system board has six 72-pin DRAM sockets that expand system memory to a maximum of 128 MB. These sockets accept single- and double-density SIMMs. Chapter 2 tells how to install memory modules and the different memory configurations available.

## ***Two-Channel PCI Mode 4 Enhanced-IDE Controller***

The board integrates a two-channel PCI mode 4 enhanced-integrated drive electronics (E-IDE) controller that improves data transfer rate and supports bus master IDE. It also has E-IDE interfaces that allow the system to support four E-IDE devices, including hard disks with more than 528-MB capacity. This feature offers users increased data storage capacity.



# Features

---

## ***Super I/O Controller***

The onboard super I/O controller chip SMC37C665GT supports two UART 16450/16550-compatible serial ports and a parallel port (SPP, EPP, ECP)<sup>1</sup>. It also accommodates 1.2-/1.44-/2.88-MB disk drives allowing full-range access to 5.25-inch drives with 360-KB or 1.2-MB format and 3.5-inch drives with 720-KB, 1.44-MB or 2.88-MB format.

## ***Keyboard Connector***

The keyboard connector at the rear of the system board allows you to connect any AT-compatible keyboard. PS/2 keyboard and mouse connectors are optional.

## ***SRAM***

The system board supports 256-KB and 512-KB second-level, write-back cache.

## ***Power Management***

The AP5C features a system power-management mode that conforms to the power-saving standards of the U.S. Environmental Protection Agency (EPA) Energy Star program. See Chapter 3 for more information on the power-management mode.

---

<sup>1</sup> SPP: Standard Parallel Port  
EPP: Enhanced Parallel Port (IEEE 1284 compliant)  
ECP: Extended Capabilities Port (IEEE 1284 compliant)

# Hardware Setup 2

---

This chapter tells how to set jumpers, upgrade system memory, add expansion boards, and install the system board.

Install the CPU, memory, and set the jumpers before you install the system board inside a system housing. You may add the other components after installing the board. Read this chapter to learn about the components before you install them.

## ESD Precautions

Electrostatic discharge (ESD) can damage your CPU, disk drives, expansion boards, and other components. Always observe the following precautions before you install a system component.

1. Do not remove a component from its protective packaging until you are ready to install it.
2. Wear a wrist grounding strap and attach it to a metal part of the system unit before handling components. If a wrist strap is not available, maintain contact with the system unit throughout any procedure requiring ESD protection.

# Hardware Setup

---

## Installing a Microprocessor

The motherboard has a zero-insertion force microprocessor socket that allows you to install a Pentium CPU without using any tools.

Follow these steps to install a Pentium CPU in a ZIF-type upgrade socket:



*Make sure that the system power is OFF before installing any component.*

1. Attach the heatsink and the fan to the CPU.

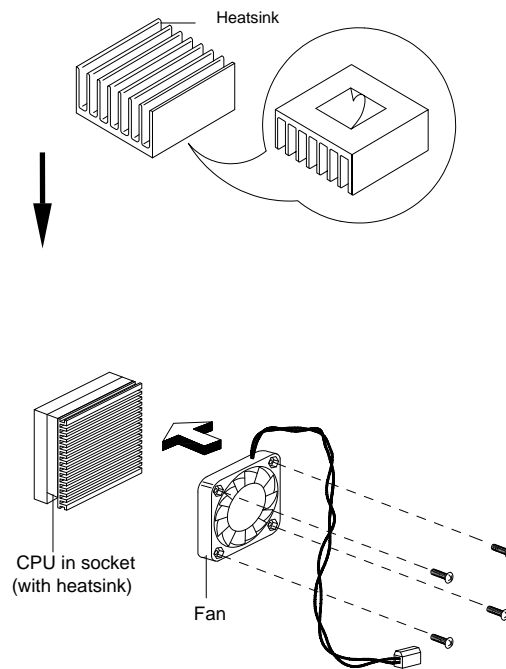

# Hardware Setup

2. Pull up the socket lever.
3. Insert the CPU with the attached heatsink and fan. Make sure that pin 1 of the CPU aligns with the hole 1 of the socket. The notched corner on the CPU indicates pin 1.
4. Pull down the socket lever to lock the CPU into the socket.

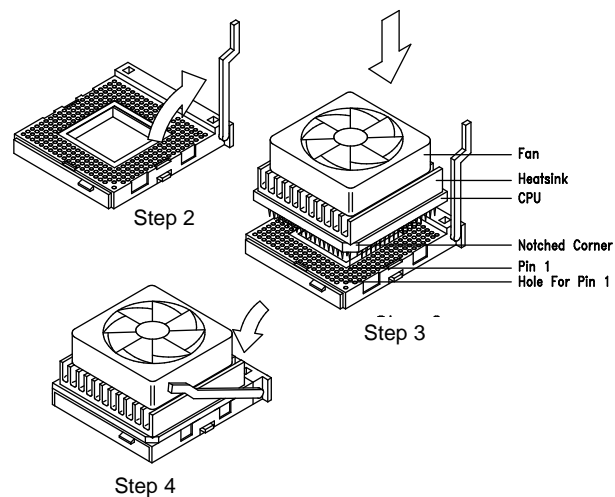

5. Plug the fan cable into the fan connector. The board has one 2-pin and one 4-pin fan connector. See the section *Connectors* for more details on fan connectors.
6. Set the jumpers accordingly. See the following sections for the correct jumper settings.

# Hardware Setup

## Upgrading the Microprocessor

Follow these steps to upgrade the Pentium CPU from 75 MHz to 90,100, 120, 133, 150 or 166 MHz:

1. Turn off the system power.
2. Pull up the socket lever.
3. Remove the installed CPU.
4. Install the upgrade CPU. Refer to the section *Installing a Microprocessor* for instructions on how to install a Pentium CPU.

## Jumper Settings

You have to change the jumper settings when you reconfigure the system. This section tells how to reset the jumpers. The figure below shows the jumper locations.

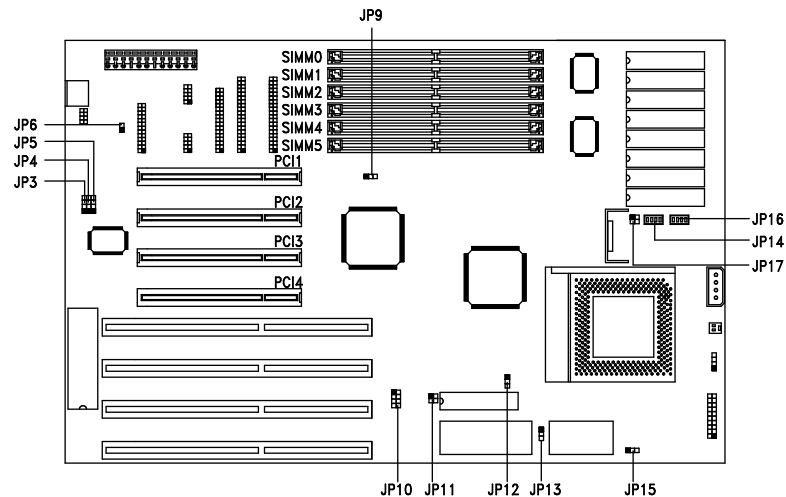

# Hardware Setup

---



*Optional jumpers:*

*JP6 - for PS/2 mouse function*

*JP14, JP16 - for 3.3V or 3.3V/5V Mix  
Mode SRAM*

Set a jumper switch as follows:

- To close a jumper switch, insert the plastic jumper cap over two pins of a jumper.
- To open a jumper switch, remove the jumper cap.

The following conventions are used to represent the proper jumper settings.

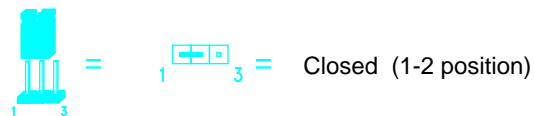
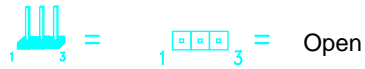





















# Hardware Setup

---

## Selecting the CPU Type

The jumpers **JP9**, **JP10** and **JP11** let you select the CPU type. The available settings are as follows:

CPU TYPE	JP9	JP10	JP11
P54C-75			
P54C-90			
P54C-100			
P54C/CS/CQS-120			
P54C/CS/CQS-133			
P54CS/CQS-150			
P54CS/CQS-166			

# Hardware Setup

## Selecting the SRAM Type (Optional)

The system board supports both 3.3V and 3.3V/5V Mix Mode SRAMs. Set the onboard switches marked as **JP14** and **JP16** according to the SRAM type. See the figure below.

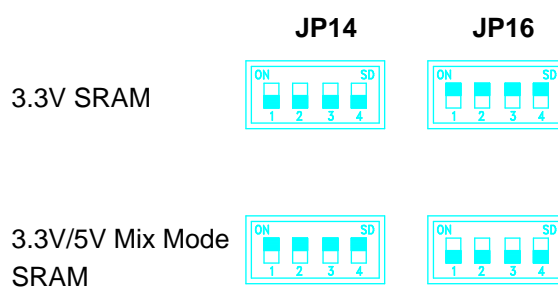

## Setting the Cache Size

The second-level cache is upgradable from 256 KB to 512 KB. See the table below for the possible cache configurations.

Cache Size	TAG SRAM (U25)	Data SRAM (U28, U30, U31, U32, U34, U35, U36, U37)
256 KB	16 Kb x 8 x 1 pc or 32 Kb x 8 x 1 pc	32 Kb x 8 x 8 pcs
512 KB	16 Kb x 8 x 1 pc or 32 Kb x 8 x 1 pc	64 Kb x 8 x 8 pcs



# Hardware Setup

---

Follow these steps to install SRAMs:

1. Locate the cache sockets on the system board. See the section *Board Layout*.
2. Insert the SRAM chip into the socket. Align the straight edge of the chip with the straight edge of the socket. Also, make sure that the cut edge of the chip corresponds to the cut edge of the cache socket. See the figure below.

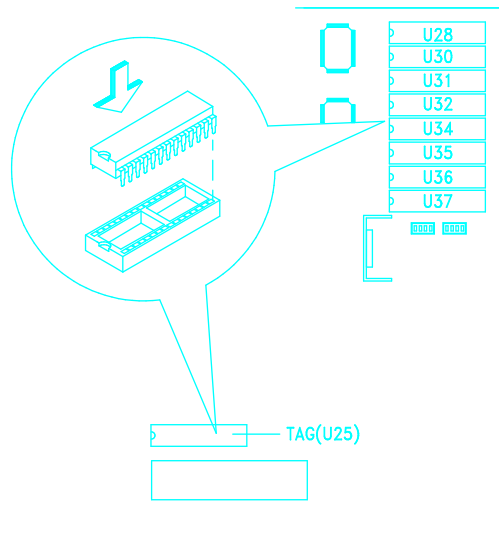

*Press the SRAM chip gently but firmly into place. Be careful not to bend the pins.*



# Hardware Setup

You must reset the 3-pin jumper **JP12** when you upgrade your cache. See the figure below for the correct settings.

CACHE SIZE	JP12
256 KB	
512 KB	

## *Selecting the Flash ROM Type*

Set the 3-pin jumper **JP13** according to the Flash ROM type. If you use 5V Flash ROM, then you must close pins 1-2 of JP13. For a 12V Flash ROM, the required setting is 2-3. The default setting is 1-2.

Flash ROM	JP13
5V	
12V	

# Hardware Setup

---

## ***Clearing the CMOS***

The 3-pin jumper **JP15** is used to clear the values in the CMOS. You need to clear the CMOS if you forget your system password. To do this, shut off the system power and short pins 2-3 of JP15 for a few seconds. Then set the jumper to the normal setting by shorting pins 1-2 with a jumper cap. Enter Setup to specify a new password.

### **JP15**

Default



Clear CMOS



## ***Enabling the PS/2 Mouse (Optional)***

The 2-pin jumper **JP6** lets you enable or disable the PS/2 mouse. To enable, simply close both pins of the jumper. To disable, leave the jumper open.

### **JP6**

Enabled



Disabled



# Hardware Setup

## ***Enabling the Onboard Super I/O Controller***

The onboard super I/O controller is SMC37C665GT. If you want to enable or disable the onboard I/O controller then you must reset the 3-pin jumper marked **JP5** on the system board.

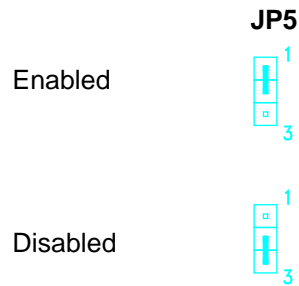

## ***Selecting the ECP DMA Channel***

The 3-pin jumpers **JP3** and **JP4** let you select the DMA channel for ECP function. The available channels are DMA 3 and DMA 1.



# Hardware Setup

---

## Memory Configuration

The system board supports a maximum memory of 128 MB. The six 72-pin SIMM sockets accommodate 4- and 16-MB single-density SIMMs, and 8- and 32-MB double-density SIMMs, with or without the Extended Data Output (EDO) function. The EDO feature expands data transfer cycle, thus improves memory performance. All SIMMs support a DRAM speed of 70/60 ns (or less). Refer to section *Board Layout* and see the figure for the location of the SIMMs.

The table below lists the SIMM types and their corresponding capacities.

<b>SIMM Type</b>	<b>Capacity</b>
1 Mb x 32/36	4 MB
2 Mb x 32/36	8 MB
4 Mb x 32/36	16 MB
8 Mb x 32/36	32 MB

# Hardware Setup

The following are the possible SIMM configurations.

Total Memory	SIMM 0/1	SIMM 2/3	SIMM 4/5
8 MB	4 MB x 2		
16 MB	4 MB x 2	4 MB x 2	
16 MB	8 MB x 2		
24 MB	4 MB x 2	4 MB x 2	4 MB x 2
24 MB	8 MB x 2	4 MB x 2	
32 MB	8 MB x 2	4 MB x 2	4 MB x 2
32 MB	8 MB x 2	8 MB x 2	
32 MB	16 MB x 2		
40 MB	8 MB x 2	8 MB x 2	4 MB x 2
40 MB	16 MB x 2	4 MB x 2	
48 MB	16 MB x 2	4 MB x 2	4 MB x 2
48 MB	16 MB x 2	8 MB x 2	
56 MB	16 MB x 2	8 MB x 2	4 MB x 2
64 MB	8 MB x 2	8 MB x 2	
64 MB	16 MB x 2	16 MB x 2	
64 MB	32 MB x 2		
72 MB	32 MB x 2	4 MB x 2	
80 MB	32 MB x 2	4 MB x 2	4 MB x 2
80 MB	32 MB x 2	8 MB x 2	
88 MB	32 MB x 2	8 MB x 2	4 MB x 2
96 MB	32 MB x 2	16 MB x 2	
104 MB	32 MB x 2	16 MB x 2	4 MB x 2
112 MB	32 MB x 2	8 MB x 2	16 MB x 2
128 MB	32 MB x 2	16 MB x 2	16 MB x 2
128 MB	32 MB x 2	32 MB x 2	

# Hardware Setup

---

## *Installing a SIMM*



*Observe the ESD precautions when installing components.*

Follow these steps to install a SIMM:

1. Slip a SIMM at a 45° angle into a socket with the component side facing down. Always install SIMMs beginning with Bank 0.



*Be careful when inserting or removing SIMMs. Forcing a SIMM in or out of a socket can damage the socket or the SIMM (or both).*

2. Gently push the SIMM up until the pegs of the socket slip into the holes on the SIMM and the holding clips lock the SIMM into a vertical position.



*The SIMM should be at a 90° angle when installed.*

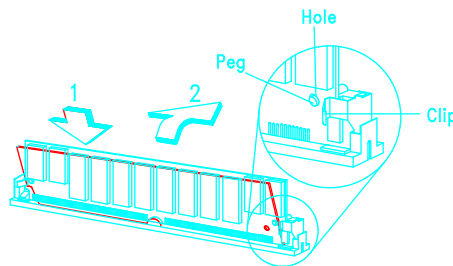

# Hardware Setup

---

## ***Removing a SIMM***

1. Press the holding clips on both sides of the SIMM outward to release it.
2. Press the SIMM downward to about a 45° angle.
3. Gently pull the SIMM out of the socket.

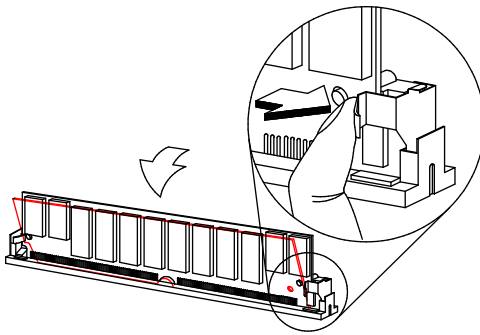



# Hardware Setup

---

## Connectors

### *Multifunction Connector*

This 20-pin connector is marked **CN14** on the system board. It supports a number of system functions: green mode LED, break switch, keylock, and speaker. Attach the front panel connectors to the corresponding pins as in the illustration below.

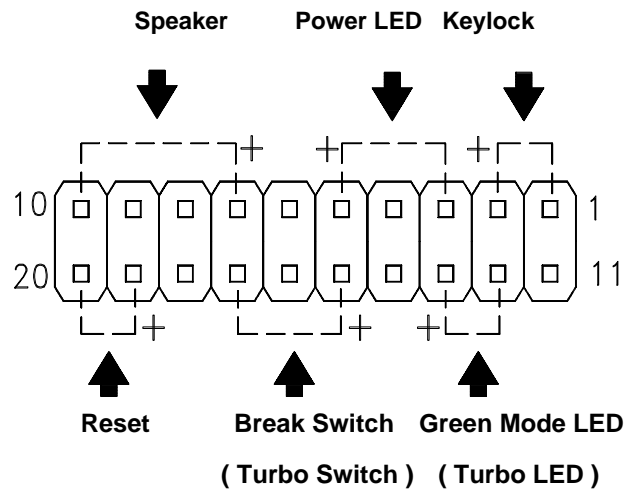

Some housings have a five-pin connector for the keylock and power LED. See the following illustration.

# Hardware Setup

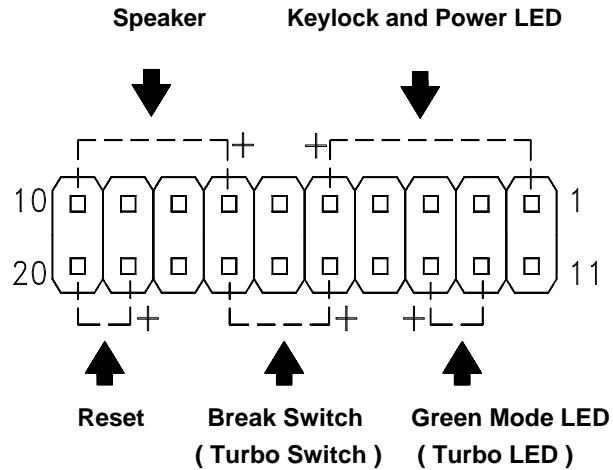

Other housings may have a 12-pin connector. If your housing has this type of connector, plug it into CN14 as shown in the following figure. Make sure that the red wire of the connector connects to pin 11.

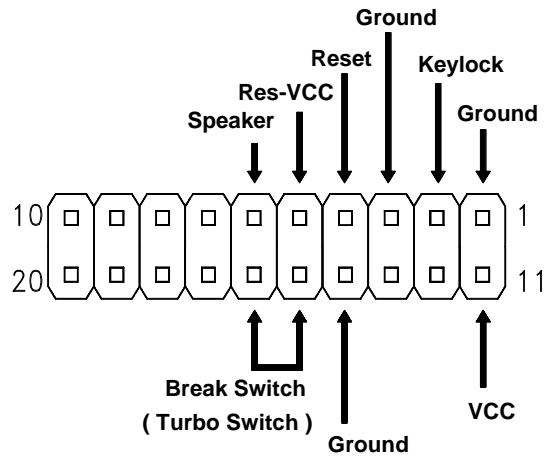

# Hardware Setup

---

## ***Break Switch***

The break switch is originally the turbo switch. It gives the user the option to directly enter the system suspend mode by setting the switch to the on position. To set, simply press the switch. Make sure that the break switch is at the off position before you set it to the on position. To set it to the off position, simply press the switch to release it from the on position.

## ***Keyboard Connector***

The keyboard connector is a 5-pin, AT-compatible connector. The following figure shows how to connect a keyboard.

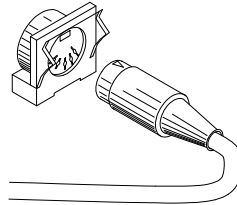

*The PS/2 keyboard connector is optional.*

# Hardware Setup

---

## ***Power Connector***

A standard power supply has two cables with six wires each. Attach these cables to the power connector on the board in such a way that all the black wires are in the center. The power connector is marked **CN4** on the system board.

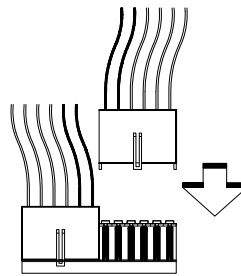

# Hardware Setup

---

## *Fan Connectors*

The board has one 4-pin and one 2-pin fan connector. The 4-pin fan connector is marked **CN11** on the system board and the 2-pin is marked **CN12**. Figure below shows the pin configuration of each connector.

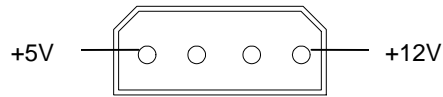

**4-PIN FAN CONNECTOR (CN11)**

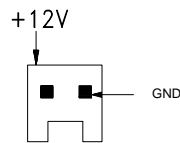

**2-PIN FAN CONNECTOR (CN12)**

# Hardware Setup

---

## Installation

The full baby-AT size of the AP5C system board easily fits most housings. It has mounting holes that conform to the standard system housing.

Some housings may differ slightly in design, requiring additional steps to install the board. Read the documentation that comes with the housing.



*Make sure that you have already installed the system board components like the CPU and memory, and have set the appropriate jumpers before you proceed.*

## ***Installing the System Board***

1. Open the system housing.
2. Use at least two screws that come with the housing to secure the board.
3. Attach the power supply cables to the power connector and the front panel connectors to the multifunction connector. See the section *Connectors*.
4. Install any additional components that you have not yet installed.

# Hardware Setup

---

## *Installing Expansion Boards*

Install any expansion boards after you have installed the system board into the housing.

Follow these steps to install an expansion board.

1. Remove the bracket opposite the slot that you want to use. Save the cover for future use. Save the screw to secure the expansion board.
2. Remove the board from its protective packaging.
3. Gently insert the golden edge of the board into the slot until it fits into place.

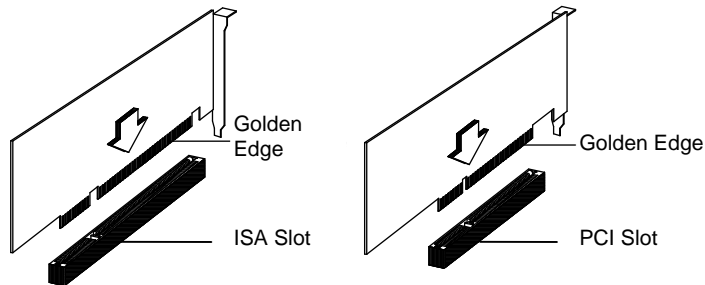

4. Secure the board bracket with the screw.

## AMI BIOS Setup Main Menu

The AMI BIOS Setup Main Menu appears below. Press C to enter the system menu.

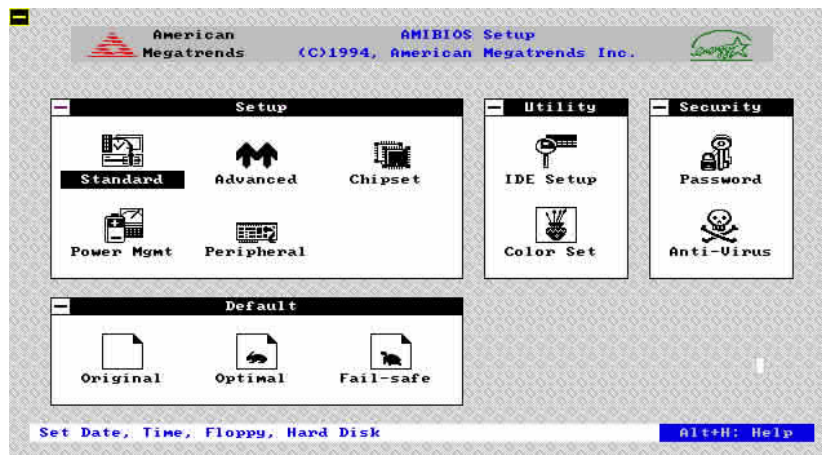

The AMI BIOS is in Windows form. You can use either the keyboard or a mouse to move between the items. To select among the Setup groups, use V to highlight the selected group or simply click on the icon of the selected Setup menu.

To select among the options, you can either use the arrow keys to move the highlight bar or simply click on the icon of the desired option.

After selecting, press E or double-click on the icon to open the menu.



# AMI BIOS

---



You can press **h** to enter the BIOS Setup screen. This also enables you to do the following:

- Resolve an address conflict due to an IRQ address assigned to multiple slots. For more information on IRQ assignment, see the section Chipset Features Setup.
- Return to the BIOS default settings if the PnP BIOS does not recognize the hardware modifications under Windows 95.

## Standard CMOS Setup

Highlight **Setup** using **V** or simply click on the Setup icon. Select **Standard** to input configuration values such as the date, time, and disk types. The Standard CMOS Setup pop-up window appears below:



# AMI BIOS

---

## ***Date/Time***

To set the date and time, highlight `Date/Time` and press `e` or double-click on the `Date/Time` icon. The following screen appears:



Use the arrow keys to move among the items. Press the `+` and `-` keys or click the `+` and `-` icons to set the current date and time. Close the window by pressing `e` or double-clicking the Control menu box in the upper-left corner of the window.

## ***Floppy Drives A and B***

To configure the floppy drive, select `Floppy A`. The following values appear on the screen:



# AMI BIOS

---

After selecting the proper setting, press **E** or double-click the Control menu box to close the window.

Select **Floppy B** and follow the same procedure to configure the second floppy drive, if present.

## ***Hard Disk Drives***

Select **Master Hard Disk** to configure the first hard disk. The following values appear on the screen:



If you cannot find your hard disk drive type on the list, select **User** and enter the disk parameters. You can also select **Utility Setup**. This automatically configures your hard disk. Refer to the section *Utility Setup* for more information.

Select **ESDI** or **SCSI** depending the device installed.

If you have two hard disks installed, select **Slave Disk** and follow the same procedure to configure the second hard disk.

# AMI BIOS

---

## Advanced CMOS Setup

The window below appears if you select the Advanced option.



The screen above does not show all the parameters of the Advanced Configuration menu. Use W or y to highlight the desired parameter. Press } to view the rest of the parameters. The following screens appear:



## AMI BIOS

---

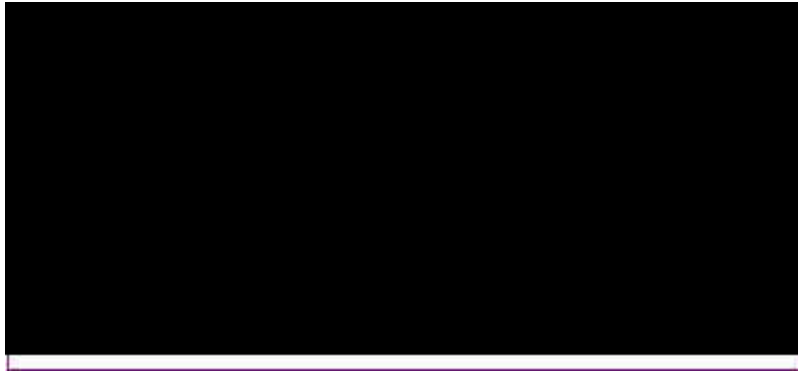

### ***Typematic Rate (Chars./Sec.)***

This parameter determines the typematic rate. The typematic rate settings are 15, 20, 30 and Disabled. The default setting is 30. Select Disabled to disregard the rate setting.

# AMI BIOS

---

## ***System Keyboard***

Set this parameter to `Present` if there is a keyboard connected to the system. However, some servers may not have keyboards. Select `Absent` if there is no keyboard present.

## ***Primary Display***

This function detects the type of VGA in use. The settings are `VGA/EGA`, `CGA 40 x 25`, `CGA 80 x 25`, `Mono`, and `Absent`. The default setting is `VGA/EGA`.

## ***PS/2 Mouse Support***

Setting this parameter to `Enabled` lets you support a PS/2 mouse. Disable the parameter to disregard the function. The default setting is `Disabled`.

## ***Above 1 MB Memory Test***

This parameter allows your system to check all available memory. Therefore, setting this parameter to `Enabled` slows down the power-on self-test. The default setting is `Disabled`.

## ***Memory Test Tick Sound***

Enabling this parameter lets you hear the tick sound during the memory test. Disable the parameter to bypass the function.

# AMI BIOS

---

## ***Hit "Del" Message Display***

This option lets you enable or disable the Hit <Del> if you want Setup message from appearing when the system boots. The default setting is Enabled.

## ***Extended BIOS RAM Area***

This function allows you to relocate the BIOS from ROM to RAM. Relocating to RAM enhances system performance as information access is faster than ROM. The parameter settings are 0:300 and DOS 1K. The default address is 0 : 300 .

## ***Wait for F1 If Any Error***

If this option is enabled, the BIOS waits for the end user to press I before continuing. If this option is disabled, the BIOS continues the boot process without waiting for I to be pressed. The default setting is Enabled.

## ***System Boot-up Num Lock***

Setting this parameter to On enables the numeric function of the numeric keypad. Set this parameter to Off to disregard the function. Disabling the numeric function allows you to use the numeric keypad for cursor control. The default setting is On.

## ***Floppy Drive Seek at Boot***

When enabled, the BIOS detects whether there is a floppy disk drive installed. Disable the parameter to bypass the function. The default setting is Disabled.

# AMI BIOS

---

## ***Floppy Drive Swapping***

This parameter allows you to swap floppy drives. For example, if you have two floppy drives (A and B), you can assign the first drive as drive B and the second drive as drive A or vice-versa. Disable the parameter to bypass the function. The default is `Disabled`.

## ***System Boot-up Sequence***

The settings are `C:`, `A:` and `A:, C:` to specify the system search sequence. The default setting is `A: , C: .`

## ***Password Checking***

The settings are `Setup` and `Always`. The `Setup` setting allows the system to boot and use the password only to protect the Setup Utility Configuration settings from being tampered with. The `Always` setting requires you to enter the password everytime you boot the system. The default setting is `Setup`.

## ***Cache Memory***

The available selections for this parameter are `Internal`, `Both` and `Disabled`. Select `Internal` if you want to enable the internal cache memory. Select `Both` if you want to use both the internal and external cache memories. Select `Disabled` to disregard the internal and external cache features.



# AMI BIOS

---

## ***System BIOS Shadow Cacheable***

The default setting for this parameter is `Enabled`. This enhances the system performance. Disabling the parameter prevents the system BIOS from being cached.

## ***Adapter ROM Control***

### **C000, 32 K**

This address is for shadowing video ROMs. Select `Shadow` to assign the address for shadowing expansion video card with ROM. Select `Cache` to assign them for cache. The default setting is `Cache`.

### **C800 ~ DC00, 16 K**

These addresses are for shadowing other expansion card ROMs. The default setting for these areas is `Disabled`. Set the addresses to `Shadow` if you want to use them for shadowing expansion cards with ROM. Set the addresses to `Cache` to assign them for cache.



*The F000 and E000 addresses are exclusively shadowed for BIOS.*

# AMI BIOS

---

## ***IDE Control***

### **IDE Auto-detect**

There are cases wherein the HDD parameters that you entered and those detected by the auto-detection function are mismatched. This causes the system not to boot. If this happens, we recommend that you set this parameter to *Disabled* to bypass the auto-detection function. The default setting is *Enabled*.

### **Block Mode**

This function enhances disk performance depending on the hard disk in use. This parameter is normally set to *Auto*. This setting allows data transfer in block (multiple sectors) by increasing the data transfer rate. The other selections for this parameter are *2 S/B*, *4 S/B*, *8 S/B*, *16 S/B*, *32 S/B*, *64 S/B* and *Disabled*. Disable the parameter if your hard disk does not support this feature.

### **Onboard IDE Present**

The settings for this function are *Auto*, *Enabled* and *Disabled*. Select *Enabled* if you have an onboard PCI IDE. Select *Auto* to automatically detect the presence of PCI IDE. Select *Disabled* to disregard the PCI IDE function.

### **PIO Mode**

This parameter lets you set the PIO mode that your onboard PCI IDE supports. The selections are from *Mode 0* to *Mode 4*, *Auto* and *Disabled*. Set this parameter either by entering the PIO mode manually or selecting *Auto* to automatically detect the supported PIO mode. Disable the parameter to bypass the feature.

# AMI BIOS

---

## **32-bit Mode**

Enabling this function improves the hard disk performance by increasing the data transfer rate from 16-bit to 32-bit.

## **Primary 1st LBA Mode**

This enhanced IDE feature allows you to use a hard disk with a capacity higher than 528 MB. This is made possible through the Logical Block Address (LBA) mode translation. This parameter affects the primary IDE hard disk drive connected to the IDE 1 connector. The default setting is *Disabled*.

## **Primary 2nd LBA Mode**

This enhanced IDE feature allows you to use a hard disk with a capacity higher than 528 MB. This is made possible through the Logical Block Address (LBA) mode translation. This parameter affects the secondary IDE hard disk drive connected to the IDE 1 connector. The default setting is *Disabled*.

## **Secondary 1st LBA Mode**

This enhanced IDE feature allows you to use a hard disk with a capacity higher than 528 MB. This is made possible through the Logical Block Address (LBA) mode translation. This parameter affects the primary IDE hard disk drive connected to the IDE 2 connector. The default setting is *Disabled*.

# AMI BIOS

---

## **Secondary 2nd LBA Mode**

This enhanced IDE feature allows you to use a hard disk with a capacity higher than 528 MB. This is made possible through the Logical Block Address (LBA) mode translation. This parameter affects the secondary IDE hard disk drive connected to the IDE 2 connector. The default setting is `Disabled`.

## ***Secondary Drives Present***

This parameter lets you install up to two IDE hard disks in the secondary channel. Select `None` if you do not have any.

## ***Chipset Setup Mode***

This function allows you to change the Chipset Setup DRAM control parameters according to the end-user type. The available settings are `End-user` and `Engineer`. We recommend that you select `End-user`. See the following section for more details on Chipset Features Setup.

# AMI BIOS

---

## Chipset Features Setup

The Chipset Features Setup controls the board's chipset settings. The controls for this menu are the same as for the previous screen.

The Chipset Setup DRAM control parameters differ depending on the Chipset Setup Mode setting in the Advanced CMOS Setup. This screen appears if you select the Chipset option from the Setup menu and if the Chipset Setup Mode parameter setting is `End-user`.



The following screen appears if your Chipset Setup Mode parameter setting is `Engineer`. Take note of the DRAM control parameters.

## AMI BIOS

---



Both screens do not show all the parameters of the Chipset Setup menu. Use W or Y to highlight the desired parameter. Press } to view the rest of the parameters. The following screens appear regardless of the end-user type or the Chipset Setup Mode parameter setting:



# AMI BIOS

---



# AMI BIOS

---

## ***SRAM Type***

This parameter allows the user to select the transmission mode that your SRAM supports. The selections are Asyn, Burst and Pipelined. The Asyn or asynchronous mode is also known as the start-stop-bit transmission, wherein the transmission of data is only one-way and per character. This is the most common form of data transmission. The Burst mode supports the simultaneous transmission of data in fixed blocks. The Pipelined-burst mode allows simultaneous transmission of data in four continuous clocks (no recovery time within each clock). The default setting is `Asyn`.

## ***DRAM Control***

### **Read/Write Leadoff\***

Before data can be accessed, the core logic must issue the memory address signal, the column address strobe (CAS) signal and the row address strobe (RAS) signal to the DRAM. However, these signals are not issued at the same time. The time difference between the issuance of these signals is called the lead-off time.

The lead-off time for read and write actions varies depending on the DRAM type. Some DRAMs may even require a longer delay to access data. This parameter allows you to set the lead-off time. The default setting is  $8 T/6T$ .

---

\* This parameter appears only if the Chipset Setup Mode parameter in the Advanced Setup screen is set to `Engineer`.



# AMI BIOS

---

## **Read Burst Timing\***

This parameter adjusts the read wait state between the L2 and the DRAM cache. Everytime the CPU reads a L2 cache miss, it reads four continuous addresses from the DRAM cache.

The available settings are X-4-4-4, X-3-3-3 and X-2-2-2. The value of X depends on the DRAM Lead-off Timing parameter setting. Faster DRAMs require shorter wait states. The default setting is X-4-4-4.

## **Write Burst Timing\***

This parameter adjusts the write wait state between the L2 and the DRAM cache. Each cache write process consists of four continuous cache cycles and therefore, this function has four numbers to adjust. The selections are X-4-4-4, X-3-3-3 and X-2-2-2. The value of X depends on the DRAM Lead-off Timing parameter setting. Faster DRAMs require shorter wait states. The default setting is X-4-4-4.

## **RAS to CAS Delay\***

This function allows you to set the wait state between the RAS and CAS signals. The available settings are 3T and 2T. The default setting 3T.

---

\* This parameter appears only if the Chipset Setup Mode parameter in the Advanced Setup screen is set to *Engineer*.

# AMI BIOS

---

## **RAS Precharge\***

This function lets you set the RAS precharge time. The RAS Precharge time refers to the period it takes for the core logic to charge the RAS signal before issuance. Some DRAMs require shorter time to charge RAS signals.

The selections for this parameter are 3T and 4T. The default setting is 3T.

## **Speed**

This DRAM control parameter lets you set the DRAM speed. The speed settings are 60 ns and 70 ns. The default setting is 70 ns.

## **Memory Hole**

This option lets you set the system memory area that you need to avoid memory conflicts. The settings are 512 ~ 640 K, 15 ~ 16 M and Disabled.

## **ISA Control**

### **8-bit I/O Recovery Time**

This parameter allows you to set the response time of the 8-bit I/O connected to your system. The range is from 1~7 SYSCLK. The default setting is 4 SYSCLK.

---

\* This parameter appears only if the Chipset Setup Mode parameter in the Advanced Setup screen is set to `Engineer`.

# AMI BIOS

---

## **16-bit I/O Recovery Time**

This parameter allows you to set the response time of the 16-bit I/O connected to your system. The range is from 1~4 SYSCLK. The default setting is 1 SYSCLK.

## ***PCI Control***

### **VGA Palette Snooping**

PCI devices support the “palette snooping” technique that enables the device to control access to their palette registers.

Set this parameter to `Enabled` to activate the palette snooping function in the PCI VGA devices installed in your system.

### **PCI-IDE Card Selection**

This parameter allows you to select the PCI-IDE card that you want to enable. The board can support a maximum of four PCI-IDE cards. The available selections are Slot 1, Slot 2, Slot 3, Slot 4, and `Absent`. Select `Absent` if you do not have any PCI card installed.

### **PCI Primary IDE INT# Line**

This parameter lets you assign an INT for the IDE device connected to your primary IDE connector. The settings are INT A, INT B, INT C, INT D, `Absent` and `Not Used`. If you do not have any PCI IDE card installed in your system and your PCI IDE Card Selection parameter setting is `Absent`, this parameter becomes non-configurable.

# AMI BIOS

---

## **PCI Secondary IDE INT# Line**

This parameter lets you assign an INT for the IDE device connected to your secondary IDE connector. The settings are INT A, INT B, INT C, INT D, Absent and Not Used. If you do not have any PCI IDE card installed in your system and your PCI IDE Card Selection parameter setting is *Absent*, this parameter becomes non-configurable.

## **NCR810 Card Used Slot**

This parameter lets you choose where to install the NCR810 SCSI card. The options are Slot 1, Slot 2, Slot 3 and Slot 4.

## **PCI Slot 1, 2, 3, and 4**

These functions allow you to assign an IRQ for each PCI slot in use. The selections are IRQs 3, 4, 5, 7, 10, 11, 12, Auto and None. Selecting *Auto* enables the BIOS to automatically assign an available IRQ for the selected PCI slot. Select *None* if the PCI slot is not in use or to disregard the slot. The default setting is *Auto*.

## ***IRQ Allocated***

### **IRQ 3, 4, 5, 7, 9, 10, 11, 14, 15 is for...**

These lines allow you to assign the available IRQs to either ISA or PCI/PnP device.

# AMI BIOS

---



*If the same IRQ address is assigned to multiple slots, an address conflict occurs. To resolve this, press **h** during boot-up. This enables the BIOS to reassign the IRQ addresses.*

## Power Management Setup

To take advantage of the power management features, select **Power Management** from the Setup menu. To select, highlight **Power Mgmt** and press **e** or double-click on the Power Management icon. The following screen appears:

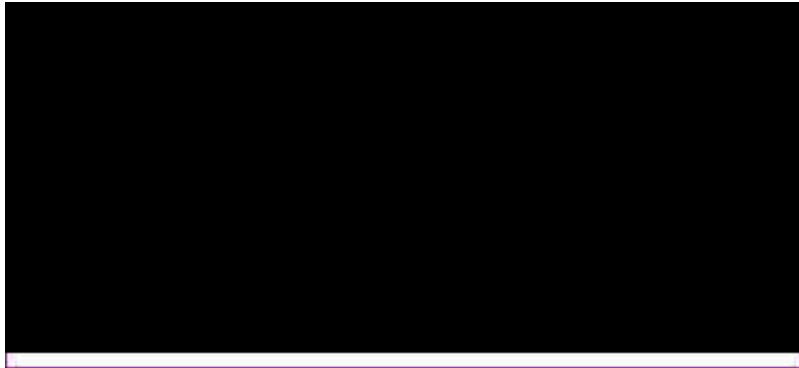

The screen above does not show all the parameters of the Power Management Setup menu. Use **w** or **y** to highlight the desired parameter. Press **}** to view the rest of the parameters. The following screens appear:

# AMI BIOS

---



## ***Advanced Power Management***

Set this parameter to `Enabled` to take advantage of the power-saving feature. Disable the parameter to bypass the feature.

## ***Full-on to Standby Timeout***

This function lets you set when to put the system into standby mode. In standby mode, the CPU clock slows down and the video signal is suspended. Full power returns when an event is detected. The settings range from 1~255 Min and Disabled.

## ***Standby to Suspend Timeout***

This function lets you set when to put the system into suspend mode. In suspend mode, the CPU clock stops, the IDE hard disk spins down and the video signal is suspended. This mode conserves the most energy. Full power returns when an event is detected. The settings range from 1~255 Min and Disabled.

# AMI BIOS

---

## ***IDE Drive Power Down in***

This option allows you to set the mode when to "spin down" your IDE hard disk. The disk returns to full speed once the system resumes to normal mode. The settings are Standby, Suspend and Disabled.

## ***Video Power Down in***

This option allows you to set the mode when to power down your video monitor. The video monitor returns to full power once the system resumes to normal mode. The settings are Standby, Suspend and Disabled.

## ***VGA Power Down Mode***

This option lets you choose the VGA power down mode. The settings are Standby, Suspend and Off.

## ***Slow Clock Ratio***

When the system enters the standby mode, the CPU clock starts to slow down. This parameter lets you set the "slow-down" clock ratio. The settings are 1:2, 1:4, 1:8, 1:16, 1:32, 1:64, and 1:128.

## ***Break Event (IRQ 3~7, 9~15)***

Enabling these parameters allow your system to monitor the IRQ activities. Any activity detected resets the power-management timers and resumes the system to normal mode.

# AMI BIOS

---



*You must enable at least one IRQ activity. Otherwise, the system stays in suspend mode.*

## Peripheral Setup

This screen appears if you select `Peripherals` or double-click on the Peripheral Setup icon from the Setup menu. The Peripheral Setup screen allows you to set up your system peripherals.



## ***Programming Mode***

The settings for this option are Auto and Manual. The Manual setting allows you to set up the screen items manually. The Auto setting sets up all the items automatically except for the Parallel Port Mode parameter.



# AMI BIOS

---

## ***Onboard FDC***

Enabling this function allows you to use the onboard floppy disk controller (FDC). The default setting is Enabled.

## ***Serial Port 1***

This parameter allows you to set the base address of serial port 1. The available settings are 3F8H, 2F8H, 3E8H, 2E8H and Disabled.

## ***Serial Port 2***

This parameter allows you to set the base address of serial port 2. The available settings are 3F8H, 2F8H, 3E8H, 2E8H and Disabled.

## ***Parallel Port***

This parameter allows you to set the base address of the parallel port. The available settings are 3BCH, 378H, 278H and Disabled..

## ***IRQ Active***

This option specifies if the parallel and serial port IRQs are active high or active low. The settings are High and Low.

## ***Parallel Port Mode***

This option lets you set the parallel port mode. The settings are Normal or Extended.

# AMI BIOS

---

## Utility Setup

### *IDE Setup*

This function allows your system to automatically configure your IDE hard disk(s). This screen appears if you select `IDE Setup`.



After a few seconds, the screen below appears showing your disk(s) parameters. Select `Yes` to accept the values.



# AMI BIOS

---

## ***Color Set***

This pop-up window appears if you select `Color Set` from the `Utility Setup` menu.



Color Set lets you select the color of your windows background. The selections are LCD, Army, Pastel, and Sky.

## **Default Setup**

Select this option to automatically set your system configuration parameters. To select, highlight `Default` and press `e`.

## ***Original***

This option loads the values that you saved before shutting off the system. The following prompt appears if you choose `Original` from the `Default Setup` menu. Select `Yes` to load the original values.



# AMI BIOS

---

## ***Optimal***

Choose this option and the BIOS configures the system using the best-case values to optimize system performance. However, these values may not be applicable to your system. If your system does not boot after choosing this setting, reconfigure it using the Fail-safe settings. Refer to the following section.

The screen below appears if you choose `Optimal` from the Default Setup menu. Select `Yes` to load the optimum values.



## ***Fail-safe***

Choose this option and the BIOS automatically configures the system using the most stable settings. These settings are not necessarily the best settings for system performance, but safe and stable enough to guarantee you that your system will boot. This is useful if you are having problems with your current system configuration and need to determine the cause.

A prompt appears if you choose `Fail-safe` from the Default Setup menu. Select `Yes` to load the fail-safe values.



# AMI BIOS

---

## Security Setup

### *Password*

The system password prevents unauthorized use of your computer. If you enabled the password feature, it is impossible to boot the computer without entering the password.

To set a password, highlight `Password` or simply double-click the Password icon. The following screen appears:



Your password can consist of up to six characters. The password does not appear on the screen. WinBIOS prompts you to retype the password. The following screen appears.

# AMI BIOS

---



If you forget your password, you must clear the CMOS RAM and reconfigure the system.

To disable the password, press **E** when prompted for your password. Press **E** again when prompted to retype the password.



# AMI BIOS

---

## ***Anti-virus***

Set this parameter to `Enabled` to protect the boot sector and partition table of your hard disk from virus intrusion. Set it to `Disabled` to bypass the feature.

A prompt appears when you select `Anti-virus` from the `Security Setup` menu:



Select `Enabled` and the screen below appears:



# AMI BIOS

---

## Exit Setup

To exit Setup, you can either double-click on the Control menu box or simply press `^`. A dialog box appears on the screen.

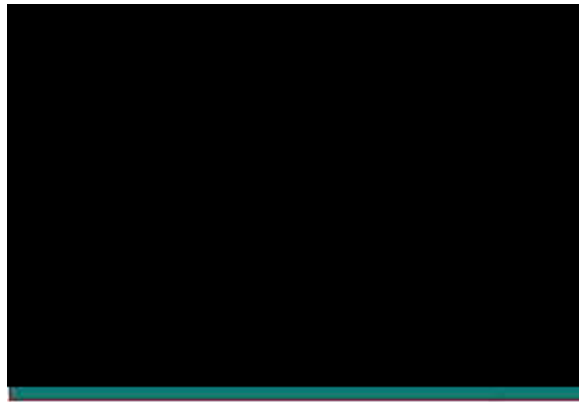

If you select `Save Changes and Exit`, the BIOS automatically saves all CMOS values before leaving Setup. Select `Do Not Save Changes and Exit` to exit Setup without saving the CMOS values. Select `Continue` to return to Setup if you want to reconfigure your system.



# AMI BIOS

---

## NCR SCSI BIOS and Drivers

The NCR 53C810 SCSI BIOS resides on the same flash memory chip as the system BIOS. To use the onboard NCR BIOS, you need to install an NCR 53C810 SCSI controller card in your system.

All SCSI devices that you install in your system require software drivers. The NCR SCSI BIOS directly supports SCSI hard disks under DOS, Windows and OS/2. It also uses DOS-format and SCO UNIX-format support floppy disk device drivers that come with the NCR 53C810 SCSI controller card. The DOS-format device drivers are for SCSI devices used with DOS, Windows NT, Novell NetWare and OS/2. The SCO UNIX-format device drivers are for SCSI devices used with SCO UNIX. These drivers offer higher performance than the direct BIOS support.

To use the device drivers, you must install them in your system hard disk drive and add them to your system configuration files. For detailed installation instructions, see the README files that come with the drivers.



*The system board also supports the AMI Flash Memory Writer Utility that allows you to upgrade the system BIOS. For more information on this utility, contact your local distributor.*

# Jumper Summary **A**

## CPU Type

CPU Type	JP9	JP10	JP11
P54C-75	1-2	1-2, 3-4	1-2, 3-4
P54C-90	2-3	1-2, 3-4	1-2
P54C-100	2-3	1-2, 3-4	3-4
P54C/CS/CQS-120	2-3	3-4, 5-6	1-2
P54C/CS/CQS-133	2-3	3-4, 5-6	3-4
P54CS/CQS-150	2-3	5-6, 7-8	1-2
P54CS/CQS-166	2-3	5-6, 7-8	3-4

## SRAM Type (Optional)

SRAM	JP14	JP16
3.3V SRAM	Off	On
3.3V/5V Mix Mode SRAM	On	Off

## Cache Size

Cache Size	JP12
256 KB	1-2
512 KB	2-3

## Flash ROM Type

Flash ROM	JP13
5V	1-2
12V	2-3

# Jumper Summary

---

## CMOS

Function	JP15
Default (Normal)	1-2
Clear CMOS	2-3

## PS/2 Mouse (Optional)

Function	JP6
Enabled	Closed
Disabled	Open

## Onboard Super I/O Controller

SMC 665GT	JP5
Enabled	1-2
Disabled	2-3

## ECP DMA Channel

ECP DMA Channel	JP3	JP4
DMA 3	1-2	1-2
DMA 1	2-3	2-3

# Jumper Summary

---

## Onboard Connectors

Connector	Function
CN1	AT-keyboard connector
CN2	PS/2 keyboard connector (optional)
CN3	PS/2 mouse connector (optional)
CN4	Power connector
CN5	Parallel port connector
CN6	COM 2 connector
CN7	COM 1 connector
CN8	FDC connector
CN9	IDE 2 connector
CN10	IDE 1 connector
CN11	4-pin fan connector
CN12	2-pin fan connector
CN13	HDD LED connector
CN14	Multifunction connector