



Dell™ OptiPlex™ 580 Service Manual—Small Form Factor

[Working on Your Computer](#)
[Removing and Replacing Parts](#)
[Specifications](#)
[System Board Layout](#)
[System Setup](#)
[Diagnostics](#)

Notes, Cautions, and Warnings

-  **NOTE:** A NOTE indicates important information that helps you make better use of your computer.
-  **CAUTION:** A CAUTION indicates potential damage to hardware or loss of data if instructions are not followed.
-  **WARNING:** A WARNING indicates a potential for property damage, personal injury, or death.

If you purchased a Dell™ n Series computer, any references in this document to Microsoft® Windows® operating systems are not applicable.

Information in this document is subject to change without notice.
© 2010 Dell Inc. All rights reserved.

Reproduction of this material in any manner whatsoever without the written permission of Dell Inc. is strictly forbidden.

Trademarks used in this text: *Dell*, the *DELL* logo, and *OptiPlex* are trademarks of Dell Inc.; *ATI Radeon* is a trademarks of Advanced Micro Devices, Inc.; *Intel* and *Core* are either trademarks or registered trademarks of Intel Corporation; *AMD Athlon*, *AMD Sempron*, and combinations thereof are trademarks of Advanced Micro Devices, Inc.; *Blu-ray Disc* is a trademark of the Blu-ray Disc Association; *Microsoft*, *Windows*, *Windows Vista*, and the *Windows Vista* start button are either trademarks or registered trademarks of Microsoft Corporation in the United States and/or other countries.

Other trademarks and trade names may be used in this document to refer to either the entities claiming the marks and names or their products. Dell Inc. disclaims any proprietary interest in trademarks and trade names other than its own.

April 2010 Rev. A00

[Back to Contents Page](#)

Coin-Cell Battery

Dell™ OptiPlex™ 580 Service Manual—Small Form Factor



WARNING: Before working inside your computer, read the safety information that shipped with your computer. For additional safety best practices information, see the Regulatory Compliance Homepage at www.dell.com/regulatory_compliance.

Removing the Coin-Cell Battery

1. Follow the procedures in [Before Working Inside Your Computer](#).
2. Remove the [hard-drive assembly](#).
3. Press in on the coin-cell battery release latch.

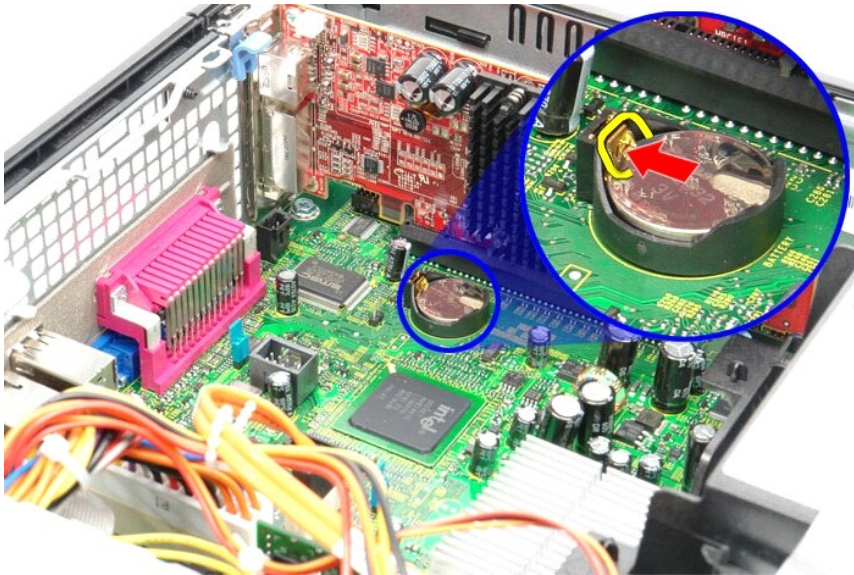

3. Remove the coin-cell battery from the computer.

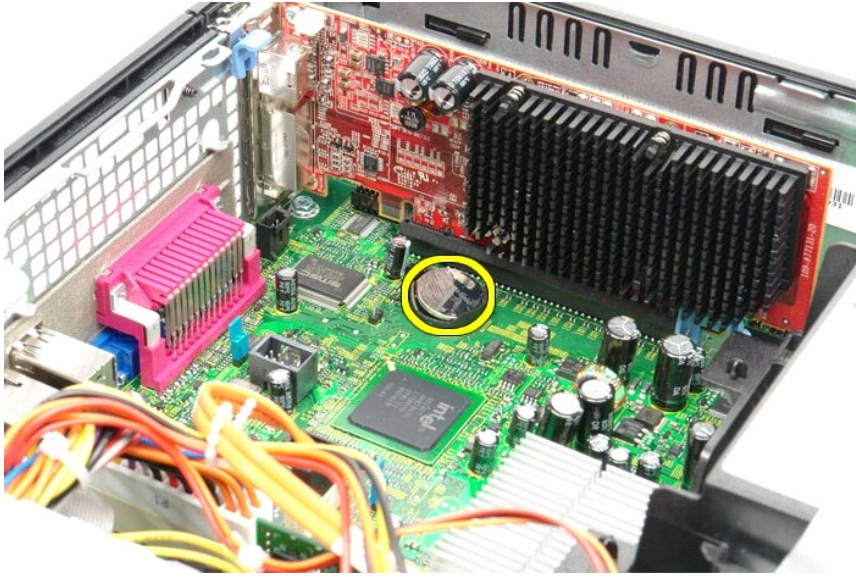

Replacing the Coin-Cell Battery

To replace the coin-cell battery, perform the above steps in reverse order.

[Back to Contents Page](#)

[Back to Contents Page](#)

Cover

Dell™ OptiPlex™ 580 Service Manual—Small Form Factor



⚠ WARNING: Before working inside your computer, read the safety information that shipped with your computer. For additional safety best practices information, see the Regulatory Compliance Homepage at www.dell.com/regulatory_compliance.

Removing the Cover

1. Follow the procedures in [Before Working Inside Your Computer](#).
2. Slide back the cover release latch.



3. Tilt the cover from the top outward and remove the cover from the computer.



Replacing the Cover

To replace the cover, perform the above steps in reverse order.

[Back to Contents Page](#)

Diagnostics

Dell™ OptiPlex™ 580 Service Manual—Small Form Factor

- [Dell Diagnostics](#)
- [Power Button Light Codes](#)
- [Beep Codes](#)
- [Diagnostic Lights](#)

Dell Diagnostics

When to Use the Dell Diagnostics

It is recommended that you print these procedures before you begin.

- 📌 **NOTE:** The Dell Diagnostics software works only on Dell computers.
- 📌 **NOTE:** The *Drivers and Utilities* media is optional and may not ship with your computer.

Enter system setup (see [Entering System Setup](#)), review your computer's configuration information, and ensure that the device you want to test displays in System Setup and is active.

Start the Dell Diagnostics from either your hard drive or from the *Drivers and Utilities* media.

Starting the Dell Diagnostics From Your Hard Drive

1. Turn on (or restart) your computer.
2. When the DELL logo appears, press <F12> immediately.

- 📌 **NOTE:** If you see a message stating that no diagnostics utility partition has been found, run the Dell Diagnostics from your *Drivers and Utilities* media.

If you wait too long and the operating system logo appears, continue to wait until you see the Microsoft® Windows® desktop. Then shut down your computer and try again.

3. When the boot device list appears, highlight **Boot to Utility Partition** and press <Enter>.
4. When the Dell Diagnostics **Main Menu** appears, select the test that you want to run.

Starting the Dell Diagnostics From the Drivers and Utilities Disc

1. Insert the *Drivers and Utilities* disc.
2. Shut down and restart the computer.

When the DELL logo appears, press <F12> immediately.

If you wait too long and the Windows logo appears, continue to wait until you see the Windows desktop. Then shut down your computer and try again.

- 📌 **NOTE:** The next steps change the boot sequence for one time only. On the next startup, the computer boots according to the devices specified in the system setup program.

3. When the boot device list appears, highlight **Onboard or USB CD-ROM Drive** and press <Enter>.
4. Select the **Boot from CD-ROM** option from the menu that appears and press <Enter>.
5. Type 1 to start the menu and press <Enter> to proceed.
6. Select **Run the 32 Bit Dell Diagnostics** from the numbered list. If multiple versions are listed, select the version appropriate for your computer.
7. When the Dell Diagnostics **Main Menu** appears, select the test you want to run.

Dell Diagnostics Main Menu

1. After the Dell Diagnostics loads and the **Main Menu** screen appears, click the button for the option you want.

Option	Function
Express Test	Performs a quick test of devices. This test typically takes 10 to 20 minutes and requires no interaction on your part. Run Express Test first to increase the possibility of tracing the problem quickly.
Extended Test	Performs a thorough check of devices. This test typically takes 1 hour or more and requires you to answer questions periodically.
Custom Test	Tests a specific device. You can customize the tests you want to run.
Symptom Tree	Lists the most common symptoms encountered and allows you to select a test based on the symptom of the problem you are having.





- If a problem is encountered during a test, a message appears with an error code and a description of the problem. Write down the error code and problem description and follow the instructions on the screen.
- If you run a test from the **Custom Test** or **Symptom Tree** option, click the applicable tab described in the following table for more information.

Tab	Function
Results	Displays the results of the test and any error conditions encountered.
Errors	Displays error conditions encountered, error codes, and the problem description.
Help	Describes the test and may indicate requirements for running the test.
Configuration	Displays your hardware configuration for the selected device. The Dell Diagnostics obtains configuration information for all devices from system setup, memory, and various internal tests, and it displays the information in the device list in the left pane of the screen. The device list may not display the names of all the components installed on your computer or all devices attached to your computer.
Parameters	Allows you to customize the test by changing the test settings.

- When the tests are completed, if you are running the Dell Diagnostics from the *Drivers and Utilities* disc, remove the disc.
- Close the test screen to return to the **Main Menu** screen. To exit the Dell Diagnostics and restart the computer, close the **Main Menu** screen.

Power Button Light Codes

The diagnostic lights give much more information about the system state, but legacy power light states are also supported in your computer. The power light states are shown in following table.

Power Light State	Description
 Off	Power is off, light is blank.
 Blinking Amber	Initial state of light at power up. Indicates system has power, but the POWER_GOOD signal is not yet active. If the Hard Drive light is off , it is probable that the power supply needs to be replaced. If the Hard Drive light on , it is probable that an onboard regulator or VRM has failed. Look at the diagnostic lights for further information.
 Solid Amber	Second state of the light at power up. Indicates the POWER_GOOD signal is active and it is probable that the power supply is fine. Look at the diagnostic lights for further information.
 Blinking Green	System is in a low power state, either S1 or S3. Look at the diagnostic lights to determine which state the system is in.
 Solid Green	System is in S0 state, the normal power state of a functioning machine. The BIOS will turn the light to this state to indicate it has started fetching op-codes.

Beep Codes

If the monitor cannot display error messages during the POST, the computer may emit a series of beeps that identifies the problem or that can help you identify a faulty component or assembly. The following table lists the beep codes that may be generated during the POST. Most beep codes indicate a fatal error that prevents the computer from completing the boot routine until the indicated condition is corrected.

Code	Cause
one long, two short	Memory test failure
one long, three short, two short	No Memory
one short	<F12> key pressed
two short, one long	ROM BIOS checksum failure

Diagnostic Lights

To help troubleshoot a problem, your computer has four lights labeled 1, 2, 3, and 4 on the bank panel. When the computer starts normally, the lights flash before turning off. If the computer malfunctions, the sequence of the lights help to identify the problem.

 **NOTE:** After the computer completes POST, all four lights turn off before booting to the operating system.

Light Pattern	Problem Description	Suggested Resolution
	The computer is in a normal <i>off</i> condition or a possible pre-BIOS failure has occurred.	<ol style="list-style-type: none"> Plug the computer into a working electrical outlet. If the problem persists, contact Dell.

	The diagnostic lights are not lit after the computer successfully boots to the operating system.	
①②③④	A possible processor failure has occurred.	<ul style="list-style-type: none"> 1 Reseat the processor (see Processor information for your computer). 1 If the problem persists, contact Dell.
①②③④	Memory modules are detected, but a memory failure has occurred.	<ul style="list-style-type: none"> 1 If two or more memory modules are installed, remove the modules, then reinstall one module and restart the computer. If the computer starts normally, continue to install additional memory modules (one at a time) until you have identified a faulty module or reinstalled all modules without error. 1 If available, install working memory of the same type into your computer. 1 If the problem persists, contact Dell.
①②③④	A possible graphics card failure has occurred.	<ul style="list-style-type: none"> 1 Reseat any installed graphics cards. 1 If available, install a working graphics card into your computer. 1 If the problem persists, contact Dell.
①②③④	A possible floppy drive or hard drive failure has occurred.	Reseat all power and data cables.
①②③④	A possible USB failure has occurred.	Reinstall all USB devices and check all cable connections.
①②③④	No memory modules are detected.	<ul style="list-style-type: none"> 1 If two or more memory modules are installed, remove the modules, then reinstall one module and restart the computer. If the computer starts normally, continue to install additional memory modules (one at a time) until you have identified a faulty module or reinstalled all modules without error. 1 If available, install working memory of the same type into your computer. 1 If the problem persists, contact Dell.
①②③④	Memory modules are detected, but a memory configuration or compatibility error has occurred.	<ul style="list-style-type: none"> 1 Ensure that no special requirements for memory module/connector placement exist. 1 Ensure that the memory you are using is supported by your computer (see the Specifications section for your computer). 1 If the problem persists, contact Dell.
①②③④	A possible expansion card failure has occurred.	<ul style="list-style-type: none"> 1 Determine if a conflict exists by removing an expansion card (not a graphics card) and restarting the computer. 1 If the problem persists, reinstall the card you removed, then remove a different card and restart the computer. 1 Repeat this process for each expansion card installed. If the computer starts normally, troubleshoot the last card removed from the computer for resource conflicts. 1 If the problem persists, contact Dell.
①②③④	Another failure has occurred.	<ul style="list-style-type: none"> 1 Ensure that all hard drive and optical drive cables are properly connected to the system board. 1 If there is an error message on the screen identifying a problem with a device (such as the floppy drive or hard drive), check the device to make sure it is functioning properly. 1 If the operating system is attempting to boot from a device (such as the floppy drive or optical drive), check system setup to ensure the boot sequence is correct for the devices installed on your computer. 1 If the problem persists, contact Dell.

[Back to Contents Page](#)

[Back to Contents Page](#)

Expansion Card

Dell™ OptiPlex™ 580 Service Manual—Small Form Factor



⚠ WARNING: Before working inside your computer, read the safety information that shipped with your computer. For additional safety best practices information, see the Regulatory Compliance Homepage at www.dell.com/regulatory_compliance.

Removing an Expansion Card

1. Follow the procedures in [Before Working Inside Your Computer](#).
2. Push the release tab on the card retention latch from the inside, then pivot the latch open.



3. If you are removing a PCI-Express x16 video card go to [step 4](#), otherwise go to [step 5](#).
4. Press the securing tab to unlock the PCI-Express x16 video card from its connector.



5. Grasp the card by its top corners and ease it out from the connector on the system board.



Replacing an Expansion Card

To replace an expansion card, perform the above steps in reverse order.

[Back to Contents Page](#)

[Back to Contents Page](#)

Fan

Dell™ OptiPlex™ 580 Service Manual—Small Form Factor



⚠ WARNING: Before working inside your computer, read the safety information that shipped with your computer. For additional safety best practices information, see the Regulatory Compliance Homepage at www.dell.com/regulatory_compliance.

Removing the Fan

1. Follow the procedures in [Before Working Inside Your Computer](#).
2. Remove the [system board](#).
3. Remove the diagnostic-lights ribbon cable.



4. Press in on the retaining clips to release the fan from the computer chassis.



5. Tilt the fan forward and remove it from the computer chassis.

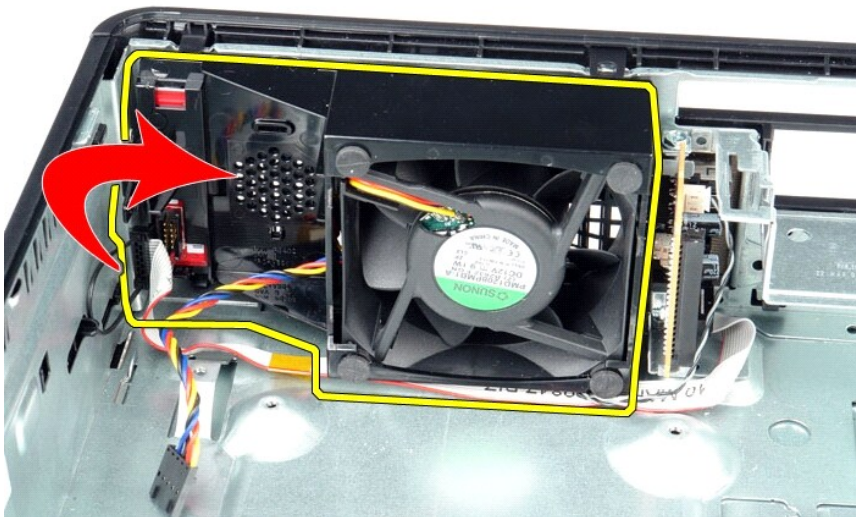

Replacing the Fan

To replace the fan, perform the above steps in reverse order.

[Back to Contents Page](#)

[Back to Contents Page](#)

Hard Drive

Dell™ OptiPlex™ 580 Service Manual—Small Form Factor



⚠ WARNING: Before working inside your computer, read the safety information that shipped with your computer. For additional safety best practices information, see the Regulatory Compliance Homepage at www.dell.com/regulatory_compliance.

Removing the Hard Drive

1. Follow the procedures in [Before Working Inside Your Computer](#).
2. Release the hard-drive cables from their restraining tie.



3. Disconnect the data cable from the system board.



4. Press the blue securing tabs on each side of the hard-drive assembly and slide the assembly up and out of the computer.

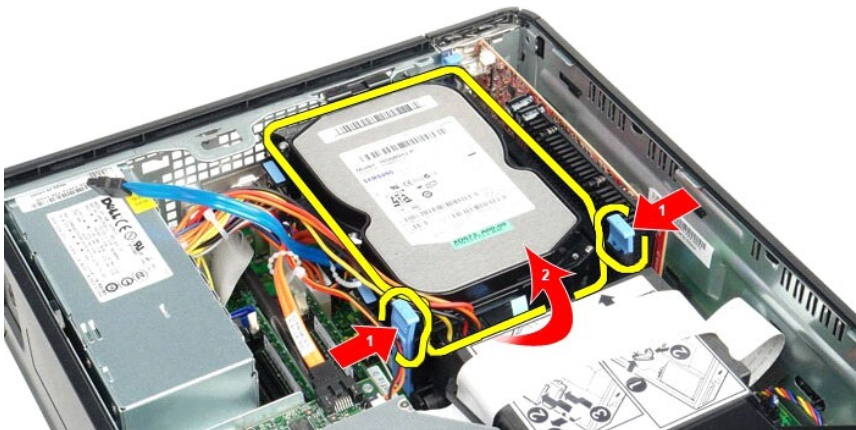

5. Disconnect the hard-drive power cable.

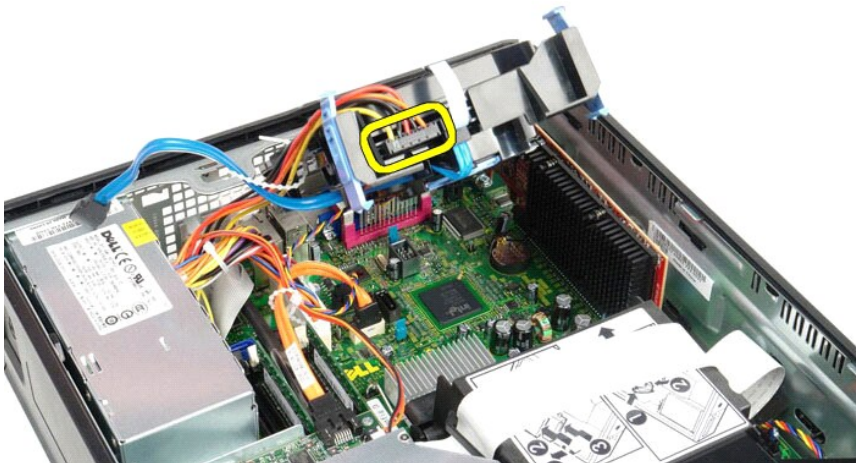

6. Disconnect the hard-drive fan cable.



7. Remove the hard-drive assembly from the computer.

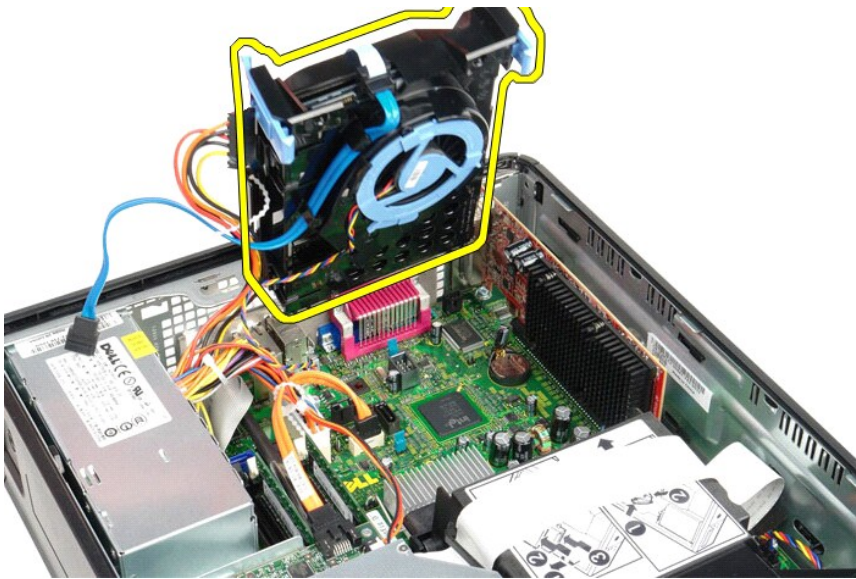

8. Pull on the blue tab to disconnect the hard-drive data cable from the hard-drive assembly.

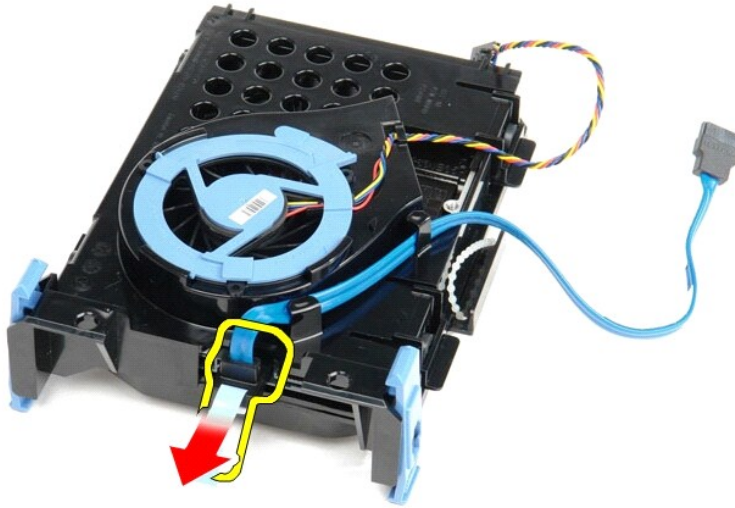

9. Remove the hard-drive data cable from the outside of the hard-drive assembly.



10. Remove the hard-drive fan cable from the outside of the hard-drive assembly.



11. Lift the blue tab and rotate it counter-clockwise to release the hard-drive fan from the hard-drive assembly.

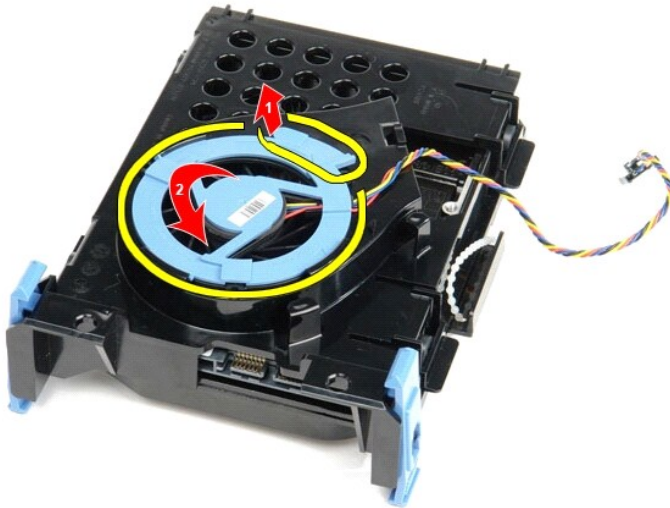

12. Remove the hard-drive fan from the hard drive assembly.

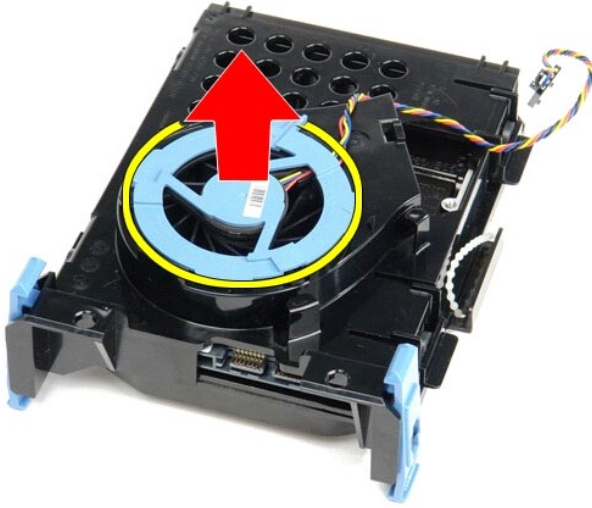

13. Pull back the blue tabs and pull forward the hard drive to remove the hard drive from the hard drive assembly.



14. Remove the hard drive from the hard-drive assembly.



Replacing the Hard Drive

To replace the hard drive, perform the above steps in reverse order.

[Back to Contents Page](#)

[Back to Contents Page](#)

Heat Sink and Processor

Dell™ OptiPlex™ 580 Service Manual—Small Form Factor



⚠ WARNING: Before working inside your computer, read the safety information that shipped with your computer. For additional safety best practices information, see the Regulatory Compliance Homepage at www.dell.com/regulatory_compliance.

Removing the Heat Sink and Processor

1. Follow the procedures in [Before Working Inside Your Computer](#).
2. Loosen the screws that secure the heat sink to the system board.

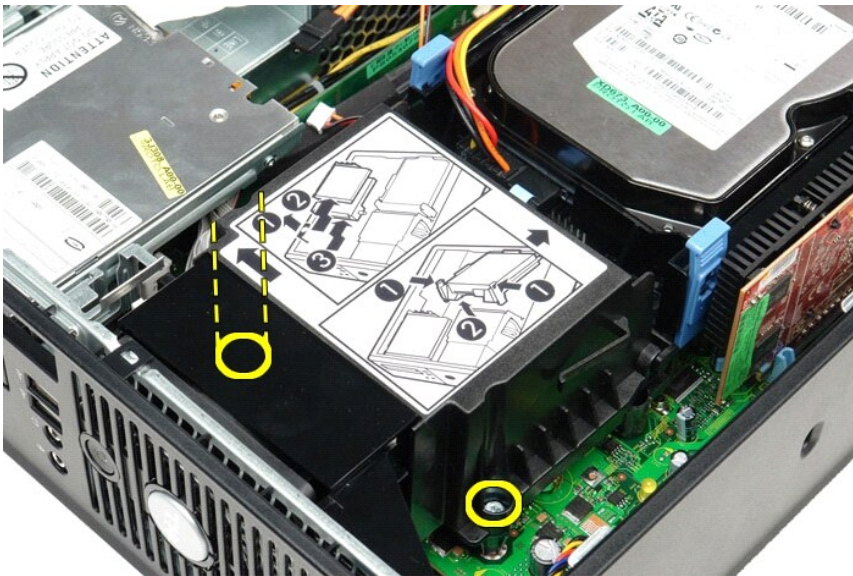

3. Rotate the heat sink toward the back of the computer and remove the heat sink from the computer.

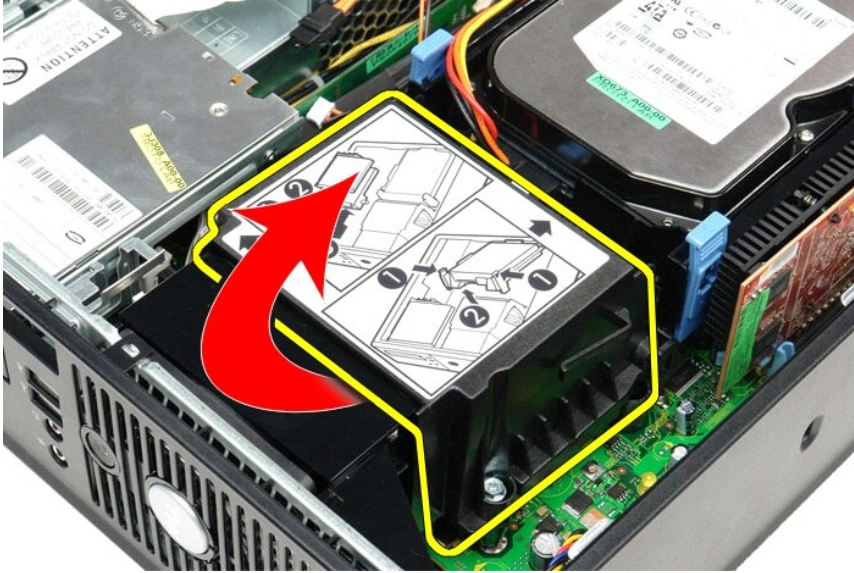

4. Press the processor cover release lever down and out to release the cover.



5. Lift the processor out of its socket on the system board.

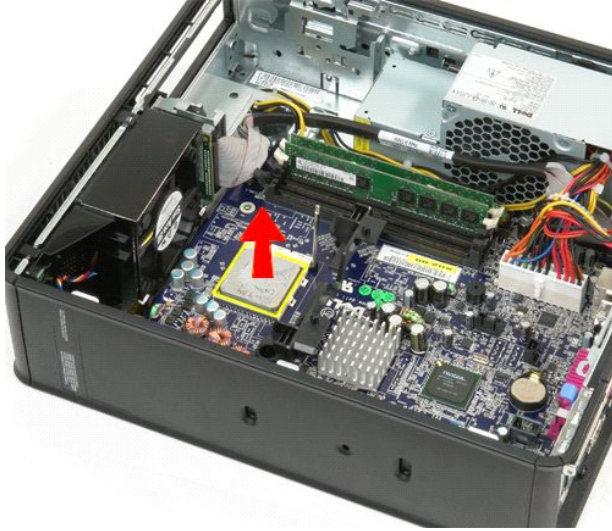

△ **CAUTION:** When replacing the processor, do not touch any of the pins inside the socket or allow any objects to fall on the pins in the socket.

Replacing the Heat Sink and Processor

To replace the heat sink and processor, perform the above steps in reverse order.

[Back to Contents Page](#)

[Back to Contents Page](#)

Chassis Intrusion Switch

Dell™ OptiPlex™ 580 Service Manual—Small Form Factor

WARNING: Before working inside your computer, read the safety information that shipped with your computer. For additional safety best practices information, see the Regulatory Compliance Homepage at www.dell.com/regulatory_compliance.

Removing the Chassis Intrusion Switch



NOTE: You may need to install Adobe® Flash® Player from Adobe.com in order to view the illustrations below.

1. Follow the procedures in [Before Working Inside Your Computer](#).
2. Remove the [hard-drive assembly](#).
3. Disconnect the chassis intrusion-switch cable from the system board.

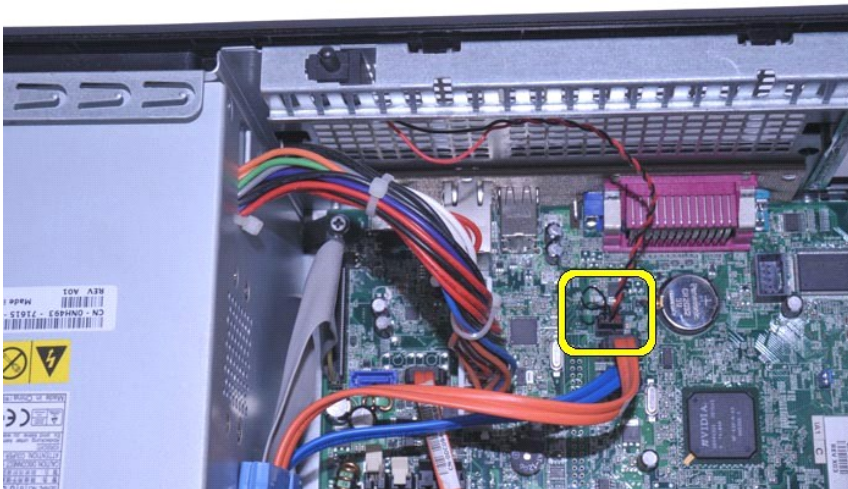

4. Slide the chassis intrusion switch from its slot in the metal bracket, and then push down the switch to remove it from the computer.



Replacing the Chassis Intrusion Switch

To replace the chassis intrusion switch, perform the above steps in reverse order.

[Back to Contents Page](#)

[Back to Contents Page](#)

Internal Speaker

Dell™ OptiPlex™ 580 Service Manual—Small Form Factor

WARNING: Before working inside your computer, read the safety information that shipped with your computer. For additional safety best practices information, see the Regulatory Compliance Homepage at www.dell.com/regulatory_compliance.

Removing the Internal Speaker



NOTE: You may need to install Adobe® Flash® Player from Adobe.com in order to view the illustrations below.

1. Follow the procedures in [Before Working Inside Your Computer](#).
2. Remove the [hard drive](#).
3. Disconnect the internal-speaker cable from the system board.
4. Press the locking tab and slide the internal speaker upward to remove it from the computer.

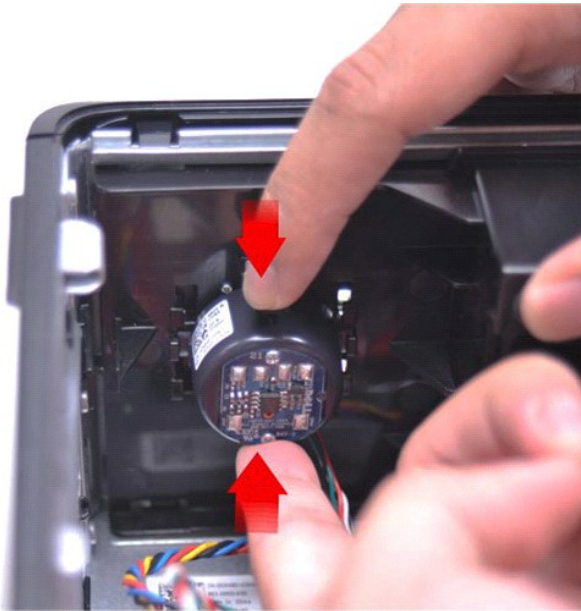

Replacing the Internal Speaker

To replace the internal speaker, perform the above steps in reverse order.

[Back to Contents Page](#)

[Back to Contents Page](#)

I/O Panel

Dell™ OptiPlex™ 580 Service Manual—Small Form Factor



WARNING: Before working inside your computer, read the safety information that shipped with your computer. For additional safety best practices information, see the Regulatory Compliance Homepage at www.dell.com/regulatory_compliance.

Removing the I/O Panel

1. Follow the procedures in [Before Working Inside Your Computer](#).
2. Remove the [system board](#).
3. Remove the [fan](#).
4. Press the clips on either sides of the air temperature sensor and remove it from the computer chassis.

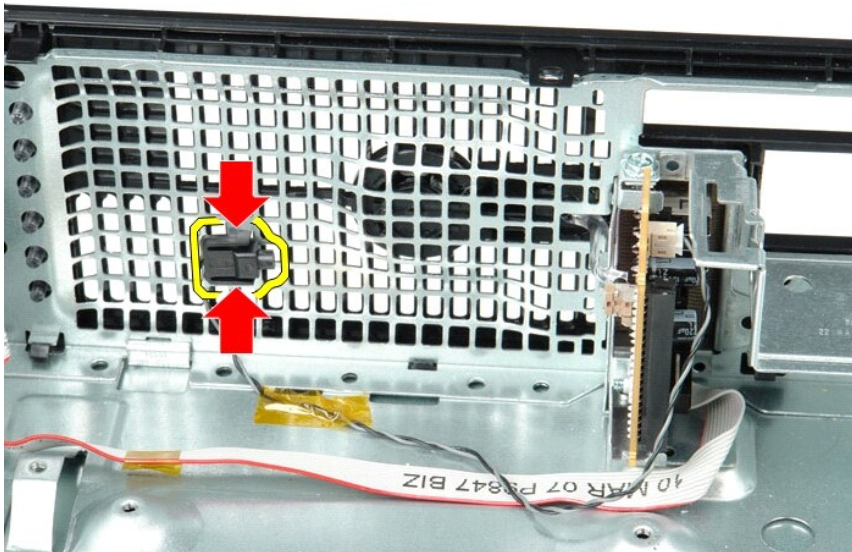

5. Remove the mounting screw that secures the I/O panel to the computer.

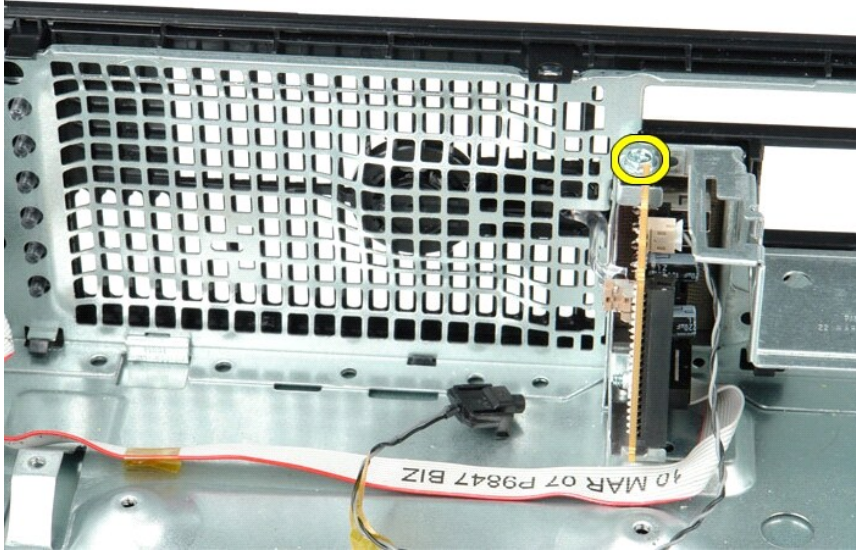

6. Ease the I/O panel back and forth to release its circular tabs from the chassis.

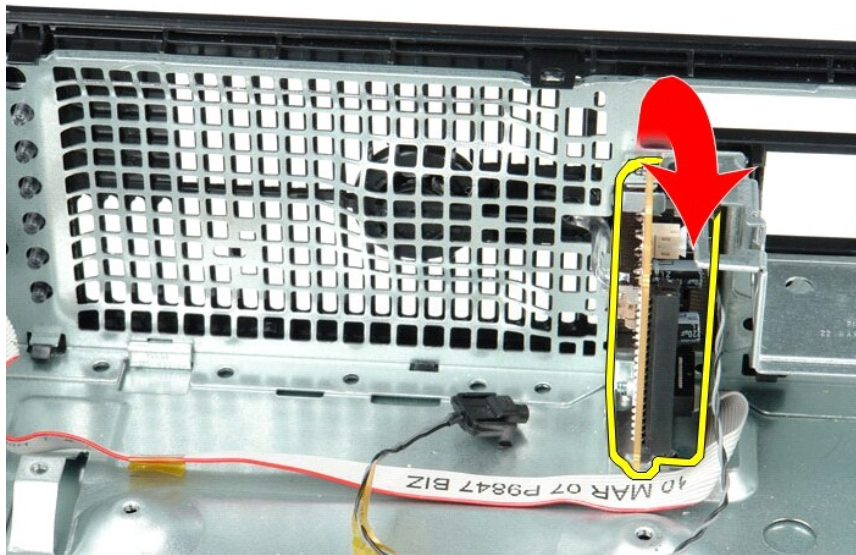

7. Remove the I/O panel from the computer.

Replacing the I/O Panel

To replace the I/O panel, perform the above steps in reverse order.

[Back to Contents Page](#)

[Back to Contents Page](#)

Memory

Dell™ OptiPlex™ 580 Service Manual—Small Form Factor



⚠ WARNING: Before working inside your computer, read the safety information that shipped with your computer. For additional safety best practices information, see the Regulatory Compliance Homepage at www.dell.com/regulatory_compliance.

Removing a Memory Module

1. Follow the procedures in [Before Working Inside Your Computer](#).
2. Push down on the memory retention clips to release the memory module.

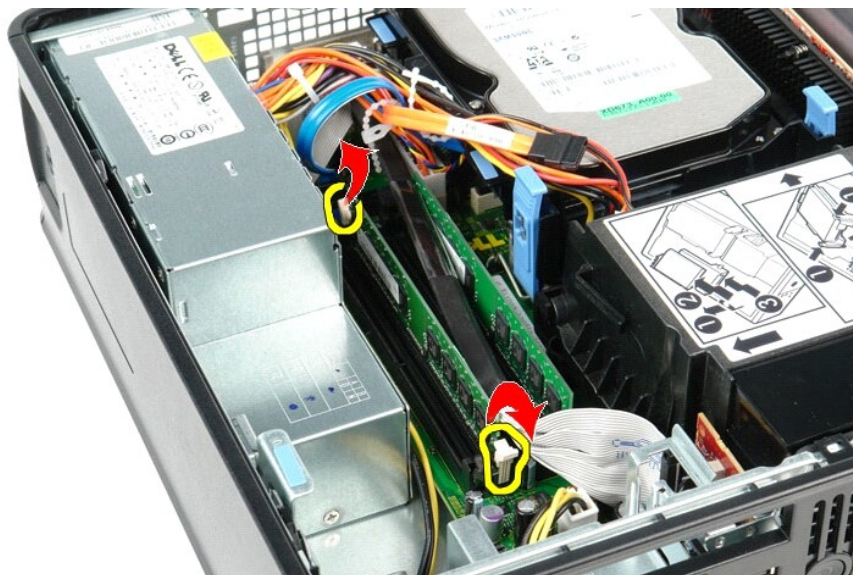

3. Lift the memory module from its connector on the system board and remove it from the computer.

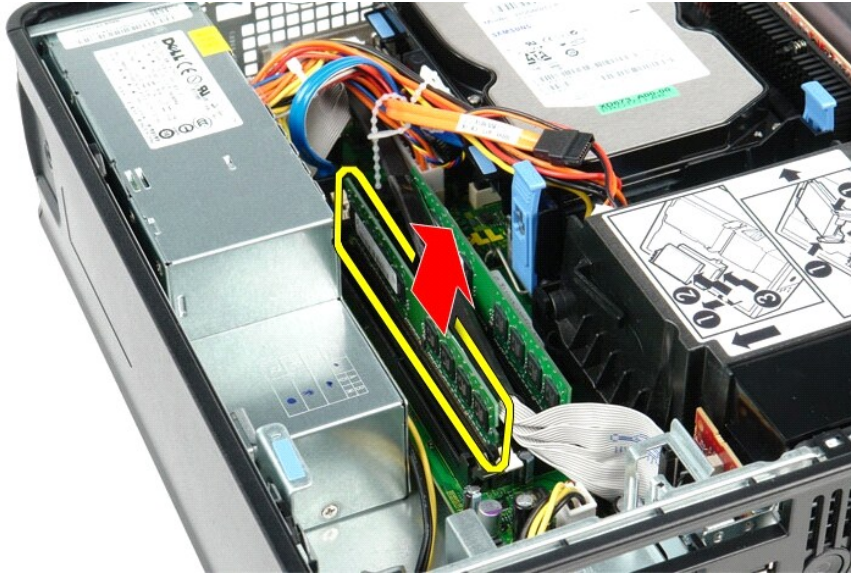

Replacing a Memory Module

To replace a memory module, perform the above steps in reverse order.

[Back to Contents Page](#)

[Back to Contents Page](#)

Optical Drive

Dell™ OptiPlex™ 580 Service Manual—Small Form Factor



⚠ WARNING: Before working inside your computer, read the safety information that shipped with your computer. For additional safety best practices information, see the Regulatory Compliance Homepage at www.dell.com/regulatory_compliance.

Removing the Optical Drive

1. Follow the procedures in [Before Working Inside Your Computer](#).
2. Disconnect the power cable from the back of the optical drive.



3. Disconnect the data cable from the back of the optical drive.



4. Pull up on the drive-release latch and slide the optical drive toward the back of the computer.



5. Lift the optical drive up and out of the computer.



Replacing the Optical Drive

To replace the optical drive, perform the above steps in reverse order.

[Back to Contents Page](#)

[Back to Contents Page](#)

Removing and Replacing Parts

Dell™ OptiPlex™ 580 Service Manual—Small Form Factor

- [Cover](#)
- [Hard Drive](#)
- [Memory](#)
- [Internal Speaker](#)
- [I/O Panel](#)
- [Power Supply](#)
- [Intrusion Switch](#)
- [Optical Drive](#)
- [Expansion Cards](#)
- [Heat Sink and Processor](#)
- [Fan](#)
- [Coin-Cell Battery](#)
- [System Board](#)

[Back to Contents Page](#)

[Back to Contents Page](#)

Power Supply

Dell™ OptiPlex™ 580 Service Manual—Small Form Factor



⚠ WARNING: Before working inside your computer, read the safety information that shipped with your computer. For additional safety best practices information, see the Regulatory Compliance Homepage at www.dell.com/regulatory_compliance.

Removing the Power Supply

1. Follow the procedures in [Before Working Inside Your Computer](#).
2. Remove the [optical drive](#).
3. Disconnect the processor power cable from the system board.

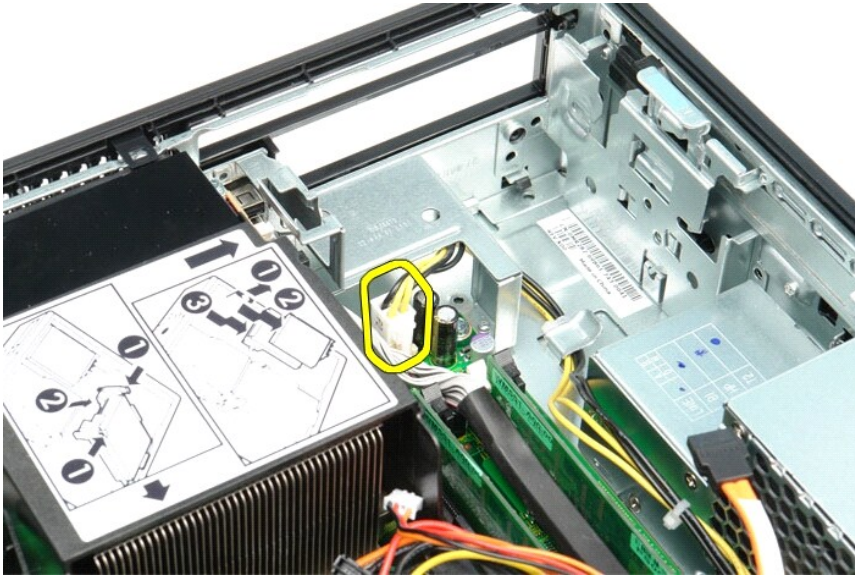

4. Remove the processor power cable from its routing guides on the chassis.

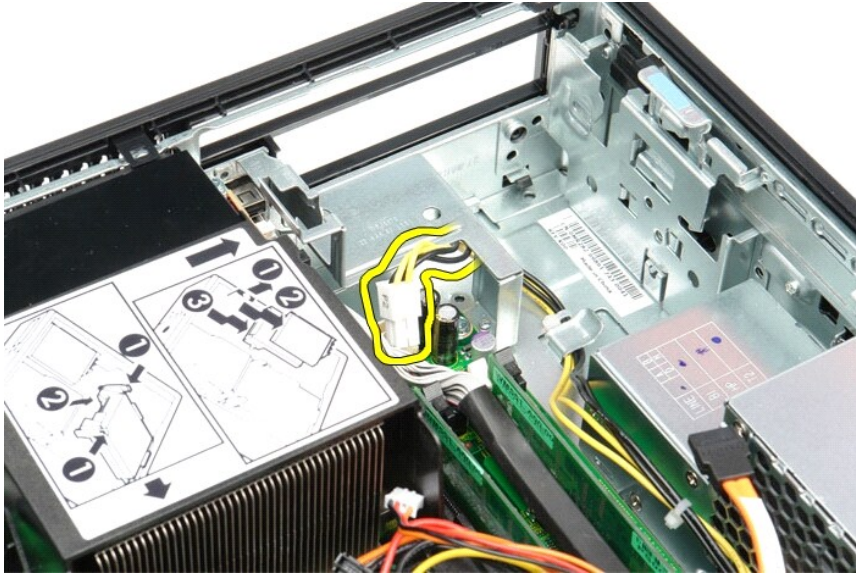

5. Press the release latch and disconnect the main power cable from the system board.



6. Remove the screws that secure the power supply to the computer chassis.



7. Slide the power supply towards the front of the computer.



8. Lift the power supply up and out of the computer.



Replacing the Power Supply

To replace the power supply, perform the above steps in reverse order.

[Back to Contents Page](#)

System Setup

Dell™ OptiPlex™ 580 Service Manual—Small Form Factor

- [Overview](#)
- [Entering System Setup](#)
- [System Setup Options](#)

Overview

Use System Setup to:

1. Change the system configuration information after you add, change, or remove any hardware in your computer.
1. Set or change a user-selectable option such as the user password.
1. View the installed amount of memory or set the type of hard drive installed.

 **CAUTION:** Do not change the settings in system setup unless you are an expert computer user. Certain changes can cause your computer to work incorrectly.

 **NOTE:** Before you use System Setup, it is recommended that you write down the System Setup screen information for future reference.

Entering System Setup

1. Turn on (or restart) your computer.
2. When the DELL logo appears, press <F2> immediately.

 **NOTE:** Keyboard failure may result when a key on the keyboard is held down for extended periods of time. To avoid possible keyboard failure, press and release <F2> in even intervals until the system setup screen appears.

If you wait too long and the operating system logo appears, continue to wait until you see the Microsoft® Windows® desktop, then shut down your computer and try again.

System Setup Screens

Options List — This field appears on the top of the system setup window. The tabbed options contain features that define the configuration of your computer, including installed hardware, power conservation, and security features.

Option Field — This field contains information about each option. In this field you can view your current settings and make changes to your settings. Use the right- and left-arrow keys to highlight an option. Press <Enter> to make that selection active.

Help Field — This field provides context sensitive help based on the options selected.

Key Functions — This field appears below the Option Field and lists keys and their functions within the active system setup field.

System Setup Options

 **NOTE:** Depending on your computer and installed devices, the items listed in this section may not appear, or may not appear exactly as listed.

System Info	
Main	
System Time	Displays current time in the format (hh:mm:ss)
System Date	Displays current date in the format (mm:dd:yy)
System	Displays the computer model number
BIOS Version	Shows the BIOS version number and date information
Service Tag	Displays the service tag of the computer
Express service code	Displays the express service code of the computer
Asset Tag	Displays the asset tag for the computer, if present
Processor Type	Displays the processor type
Processor clock speed	Displays the processor clock speed
L1 cache	Displays the amount of processor Level 1 cache

L2 Cache	Displays the amount of processor Level 2 cache
L3 Cache	Displays the amount of processor Level 3 cache
Installed Memory	Indicates the amount of installed memory
Memory Speed	Indicates the frequency of installed memory
Memory Technology	Indicates the type of installed memory
SATA 0	Displays the SATA drives connected to the SATA 0 connector
SATA 1	Displays the SATA drives connected to the SATA 1 connector
SATA 2	Displays the SATA drives connected to the SATA 2 connector
SATA 3	Displays the SATA drives connected to the SATA 3 connector
Keyboard Errors	Displays keyboard errors when set to Report. Default is Report
Advanced Settings	
CPU Information	Allows you to enable or disable the following functions: <ul style="list-style-type: none"> 1 Virtualization (enabled by default) 1 Cool & Quiet (enabled by default) 1 C1E (enabled by default)
Onboard Device	Allows you to set the mode of operation of the following devices on the system board: <ul style="list-style-type: none"> 1 GFX/Display Port <ul style="list-style-type: none"> o x6 — GFX with x16 o x8+Display Port (default) — integrated video card 1 Surround View — Enable ; Disable (default) 1 Integrated Audio — Auto; Off; On (default) 1 Integrated NIC — Off; On (default); On w/PXE; On w/RPL 1 Video Memory Size — Auto (default); 32 MB; 64 MB; 128 MB; 256 MB; 512 MB 1 Serial Port #1 — Off; 3F8/IRQ4 (default); 3E8/IRQ4; 2E8/IRQ3 1 LPT Port Mode — AT; PS/2 (default); EPP; ECP 1 LPT Port Address — 378h (default); 278h; 3BCh 1 USB controller — On (default); Off; No boot 1 Front Dual USB — On (default); Off 1 Rear Dual USB — On (default); Off 1 Rear Quad USB — On (default); Off
Sata Configuration	Allows you to configure the following: <ul style="list-style-type: none"> 1 SATA Operation — IDE; RAID; AHCI (default) 1 HDD Acoustic Mode — Performance; Suggested; Quiet; Bypass (default) 1 SATA 0, SATA 1, SATA 2, and SATA 3 — Disable; Enable (default) 1 External SATA — Disable; Enable (default) 1 SMART Reporting — Disable; Enable (default)
BIOS Events	Provides the following options: <ul style="list-style-type: none"> 1 View Event Log 1 Mark all events as read 1 Clear Event Log 1 Event Log Statistics
System Management	Allows you to configure the following: <ul style="list-style-type: none"> 1 DASH/ASF Configuration — Disable (default); Alert Only; DASH/ASF 1 Text Console Redirection — Enabled; Disabled (default)
Computrace	Allows you to permanently activate or disable the Computrace® service from the computer.
Security	
Unlock Setup Status	Indicates if the System Setup is locked or unlocked
Admin Password	Displays the status of the administrator password
System Password	Displays the status of the system password
Password Lock	Allows you to enable the system password to be changed with or without providing the admin password. <ul style="list-style-type: none"> 1 Lock (default) — You must provide the admin password to change the system password 1 Unlock — You can change the system password without providing the admin password.
Chassis Intrusion	Allows you to configure your computer's chassis intrusion switch: <ul style="list-style-type: none"> 1 On (default) — Enable chassis intrusion detection and report intrusion at power-on self test (POST) 1 Off — Disable chassis intrusion detection 1 On-Silent — Enable chassis intrusion detection, do not display any detected intrusions.
No Execute	Enables or disables the No Execute Memory Protection Technology. <ul style="list-style-type: none"> 1 On (default)

	<ul style="list-style-type: none"> 1 Off
TPM Security	<p>Enables or disables the TPM security feature.</p> <ul style="list-style-type: none"> 1 On 1 Off (default)
TPM Activation	<p>Activates or deactivates the TPM feature if it is enabled.</p> <ul style="list-style-type: none"> 1 Enable 1 Disable 1 Don't Change
Power	
AC Recovery	<p>Specifies the behavior of the system when AC power is restored after an AC power loss.</p> <ul style="list-style-type: none"> 1 Off (default) 1 On 1 Last
Auto Power On	<p>Enables the Auto Power On feature</p> <ul style="list-style-type: none"> 1 Disabled (default); 1 Enabled
Remote Wake Up	<p>Specifies if your computer can be turned on.</p> <ul style="list-style-type: none"> 1 Disabled 1 Enabled (default)
Low Power Mode	<p>Allows the system to conserve power while in hibernate mode.</p> <ul style="list-style-type: none"> 1 On (default) 1 Off
Suspend Type	<p>Specifies the power state in suspend mode.</p> <ul style="list-style-type: none"> 1 S1(POS) 1 S3(STR) (default)
Boot	
NOTE: The items displayed are dynamically updated according to the devices detected	
Fast Boot	<p>Speeds up the boot process by bypassing some compatibility steps.</p> <ul style="list-style-type: none"> 1 Off 1 On (default)
Numlock Key	<p>Turns on or off the Numlock.</p> <ul style="list-style-type: none"> 1 Off 1 On (default)
Wait for "F1" if error	<p>Waits for the F1 key to be pressed when an error occurs.</p> <ul style="list-style-type: none"> 1 Enabled (default) 1 Disabled
Post Hot Keys	<p>Specifies the post hot key messages to be displayed.</p> <ul style="list-style-type: none"> 1 Setup and Boot Menu 1 Setup 1 Boot Menu 1 None
1st Boot Device	Specifies the first boot device.
2nd Boot Device	Specifies the second boot device.
3rd Boot Device	Specified the third boot device.
4th Boot Device	Specifies the fourth boot device.
Exit	

Provides options to **Save Changes and Exit**, **Discard Changes and Exit**, and **Load Default Setting**

[Back to Contents Page](#)

[Back to Contents Page](#)

Specifications

Dell™ OptiPlex™ 580 Service Manual—Small Form Factor

- [Processor](#)
- [Memory](#)
- [Expansion Bus](#)
- [Video](#)
- [System Information](#)
- [Cards](#)
- [Drives](#)
- [External Connectors](#)
- [Controls and Lights](#)
- [Network](#)
- [Audio](#)
- [Power](#)
- [System Board Connectors](#)
- [Physical](#)
- [Environmental](#)

 **NOTE:** Offerings may vary by region. For more information regarding the configuration of your computer, click **Start→ Help and Support** and select the option to view information about your computer.

 **NOTE:** Unless otherwise stated, the specifications are identical for mini-tower, desktop, and small form factor computers.

Processor	
Type	AMD Phenom™ II AMD Athlon™ II AMD Sempron™
Level 2 (L2) cache	up to 2 MB

Memory	
Type	DDR3 SDRAM (non-ECC memory only)
Speed	1066 MHz
Connectors	four DIMM slots
Capacity	1 GB, 2 GB, or 4 GB
Minimum memory	1 GB
Maximum memory	16 GB

Video	
Integrated	ATI Radeon™ HD 4200 graphics
Discrete	PCI Express 2.0 x16 graphics adapter NOTE: The DisplayPort is automatically disabled when you configure the GFX/Display Port as PCI Express x16.
Video Memory:	
Integrated	up to 512 MB shared video memory (with system memory greater than 1536 MB)

Audio	
Integrated	Realtek ALC269Q-VB3

Network	
Integrated	Broadcom 5761 10/100/1000

System Information	
Chipset	AMD 785G chipset (RS880 + SB710)
DMA channels	seven
Interrupt levels	15
BIOS chip (NVRAM)	8 Mb SPI Serial Flash

Expansion Bus	
Bus type	PCI 2.3 PCI Express 1.0A SATA 1.0A and 2.0 USB 2.0
Bus speed:	
PCI	133 MBps
PCI Express x16	40 GBps bidirectional speed
PCI Express x1	2.5 Gbps

SATA	1.5 Gbps and 3.0 Gbps
USB	480 Mbps (high speed) 12 Mbps (full speed) 1.2 Mbps (low speed)

Cards	
PCI:	
Mini-tower	two
Desktop	one low profile card
Small form factor	N/A
PCI Express x4	one
PCI Express x16	one
NOTE: The PCI Express x16 slot is disabled when a display is connected to the integrated video connector.	

Drives	
Externally accessible:	
5.25 inch drive bay(s):	
Mini-tower	two
Desktop	one
Small form factor	one (slimline)
Internally accessible:	
3.5 inch SATA drive bay(s):	
Mini-tower	two
Desktop	one
Small form factor	one
Available Devices:	
2.5-inch SATA hard drives (with brackets)	two
3.5-inch SATA hard drive(s):	
Mini-tower	two
Desktop	one
Small form factor	one
5.25-inch optical drive (s):	
Mini-tower	two
Desktop	one
Small form factor	one (slimline)
NOTE: The Dell™ OptiPlex™ 580 Small Form Factor does not support the following combination of drives: one 3.5-inch hard drive, one 2.5-inch hard drive, and one 5.25-inch optical drive.	

External Connectors	
Audio:	
Back panel	two connectors for line-in/ microphone and line-out
Front panel	one front-panel connectors for headphones and microphone
eSATA	one 7-pin connector
Network	one RJ45 connector
Serial	one 9-pin connector; 16550C-compatible
USB:	
Front panel	two connectors
Back panel	six connectors
Video	one 15-hole VGA connector one 20-pin DisplayPort connector

System Board Connectors	
PCI 2.3:	
Mini-tower	two 120-pin connectors
Desktop	one 120-pin connector
Small form factor	none
PCI Express x4	one
PCI Express x16	one

Serial ATA:	
Mini-tower	four 7-pin connectors
Desktop	three 7-pin connectors
Small form factor	three 7-pin connectors
Memory	four 240-pin connectors
Internal USB device	none
Processor fan	one 5-pin connector
Hard-drive fan:	
Mini-tower	none
Desktop	none
Small form factor	one 5-pin connector
Front panel control	one 40-pin connector
Processor	AM3 941-pin connector
Power 12V	one 4-pin connector
Power	one 24-pin connector
PS/2 or serial connector (optional)	one 24-pin connector

Controls and Lights	
Front of the computer:	
Power button light	green light—Solid green light indicates power-on state; blinking green light indicates sleep state of the computer amber light—Solid amber light when the computer does not start indicates a problem with the system board or power supply. Blinking amber light indicates a problem with the system board
Power button	front of chassis—push button
Drive activity light	displays the SATA hard drive or optical drive activity green light—blinking green light indicates that the computer is reading data from, or writing data to, from the drive
Network connectivity light	green light—a good connection exists between the network and the computer off (no light)—the computer is not detecting a physical connection to the network
Diagnostic lights	four lights located on the front/back panel of the computer. For information on the diagnostic lights, see the <i>Service Manual</i> available on the Dell Support website at support.dell.com/manuals
Back of the computer:	
Link integrity light on integrated network adapter	green light—Link 10 Mbps orange light—Link 100 Mbps
Network activity light on integrated network adapter	yellow light

Power		
DC power supply		
Wattage:	EPA	Non-EPA
Mini-tower	255 W	305 W
Desktop	255 W	255 W
Small form factor	235 W	235 W
Maximum heat dissipation:		
Mini-tower	1041 BTU/hr.	1041 BTU/hr.
Desktop	955 BTU/hr.	955 BTU/hr.
Small form factor	938 BTU/hr.	938 BTU/hr.
Voltage:		
Mini-tower	115/230 VAC, 50/60 Hz, 3.6/1.8 A	115/230 VAC, 50/60 Hz, 3.6/1.8 A
Desktop	115/230 VAC, 50/60 Hz, 4.0/2.0 A	115/230 VAC, 50/60 Hz, 4.0/2.0 A
Small form factor	115/230 VAC, 50/60 Hz, 3.5/1.8 A	115/230 VAC, 50/60 Hz, 3.5/1.8 A
Coin-cell battery	3 V CR2032 lithium coin cell	

NOTE: Heat dissipation is calculated by using the power supply wattage rating.

NOTE: See the safety information that shipped with your computer for important voltage setting information.

Physical	
Height:	
Mini-tower	40.80 cm (16.10 inches)
Desktop	11.40 cm (4.50 inches)
Small form factor	9.30 cm (3.70 inches)
Width:	
Mini-tower	18.70 cm (7.40 inches)
Desktop	39.90 cm (15.70 inches)
Small form factor	31.40 cm (12.40 inches)
Depth:	
Mini-tower	43.30 cm (17.00 inches)
Desktop	35.30 cm (13.90 inches)
Small form factor	34.00 cm (13.40 inches)
Weight:	
Mini-tower	11.70 kg (25.80 lb)
Desktop	8.26 kg (18.20 lb)
Small form factor	6.80 kg (15.00 lb)

Environmental	
Temperature:	
Operating	10 °C to 35 °C (50 °F to 95 °F)
Storage	-40 °C to 65 °C (-40 °F to 149 °F)
Relative humidity (noncondensing)	20% to 80%
Maximum vibration:	
Operating	5 Hz-350 Hz at 0.0002 G2/Hz
Storage	5 Hz-500 Hz at 0.001 to 0.01 G2/Hz
Maximum shock:	
Operating	40 G +/- 5% with pulse duration of 2 msec +/- 10% (equivalent to 20 in/sec [51 cm/sec])
Storage	105 G +/- 5% with pulse duration of 2 msec +/- 10% (equivalent to 50 in/sec [127 cm/sec])
Altitude:	
Operating	-15.2 m to 3048 m (-50 ft to 10,000 ft)
Storage	-15.2 m to 10,668 m (-50 ft to 35,000 ft)
Airborne contaminant level	G2 or lower as defined by ISA-S71.04-1985

[Back to Contents Page](#)

System Board Layout

Dell™ OptiPlex™ 580 Service Manual—Small Form Factor

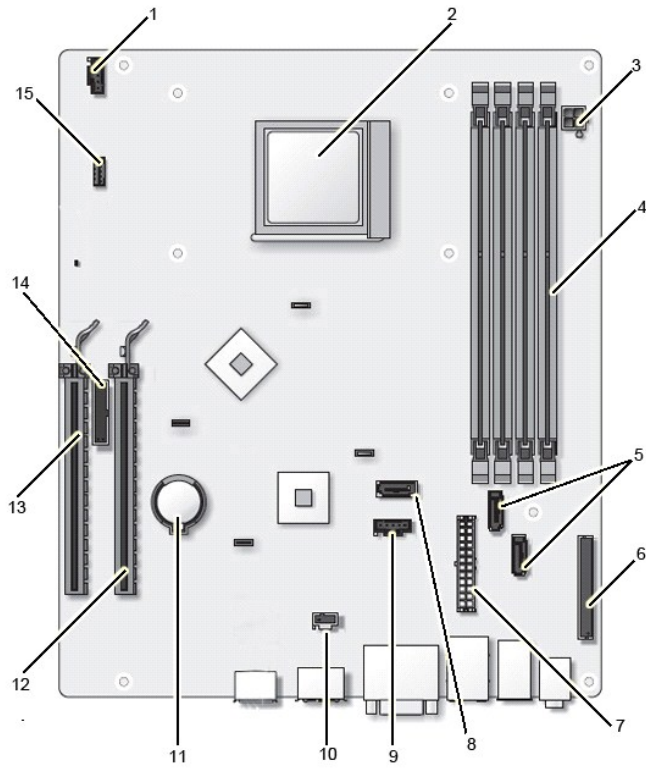

1	fan connector (FAN_CPU)	2	processor connector (CPU)
3	processor power connector (12VPOWER)	4	memory module connectors (DIMM_1, DIMM_2, DIMM_3, and DIMM_4)
5	SATA drive connectors (SATA 0 and SATA 1)	6	front panel connector (FRONTPANEL)
7	power connector (POWER)	8	SATA drive connector (SATA 2)
9	fan connector (FAN_HDD)	10	chassis intrusion switch connector (INTRUDER)
11	coin-cell battery socket (BATTERY)	12	PCI Express x16 connector (SLOT1)
13	PCI Express x4 connector (SLOT2)	14	serial or PS/2 connector (SERIAL2)
15	internal speaker (INT_SPKR)		

[Back to Contents Page](#)

System Board

Dell™ OptiPlex™ 580 Service Manual—Small Form Factor



⚠ WARNING: Before working inside your computer, read the safety information that shipped with your computer. For additional safety best practices information, see the Regulatory Compliance Homepage at www.dell.com/regulatory_compliance.

Removing the System Board

1. Follow the procedures in [Before Working Inside Your Computer](#).
2. Remove the [optical drive](#).
3. Remove the [hard drive](#).
4. Remove the [expansion card](#).
5. Remove the [memory](#).
6. Remove the [heat sink and processor](#).
7. Disconnect the processor power cable from the system board.



9. Disconnect the hard-drive and optical-drive data cables from the system board.



10. Disconnect the main power connector.



11. Remove the I/O panel cable from the system board.

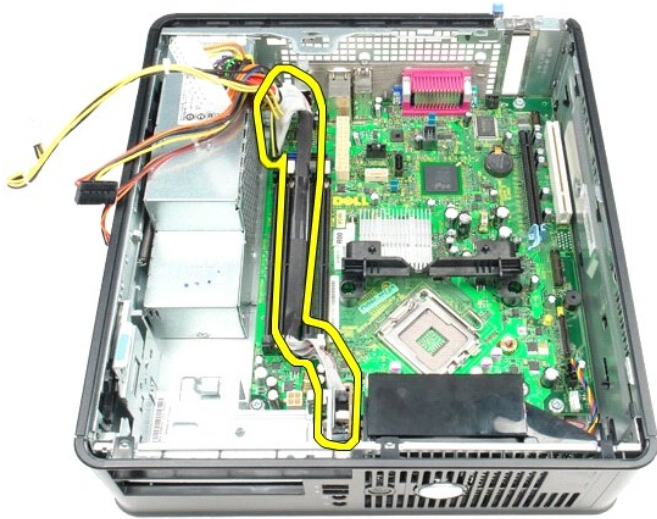

12. Disconnect the fan and internal-speaker cable from the system board.



13. Remove the screws that secure the heat-sink retention module to the system board.



14. Remove the heat-sink retention module.



15. Remove the screws that secure the system board to the computer chassis.

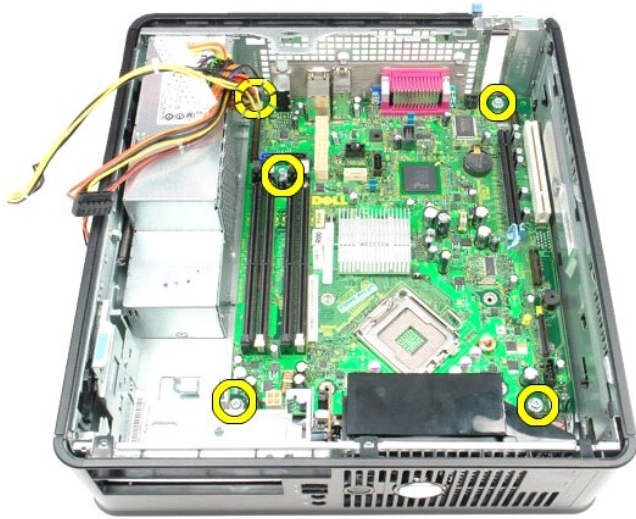

16. Remove the system board.

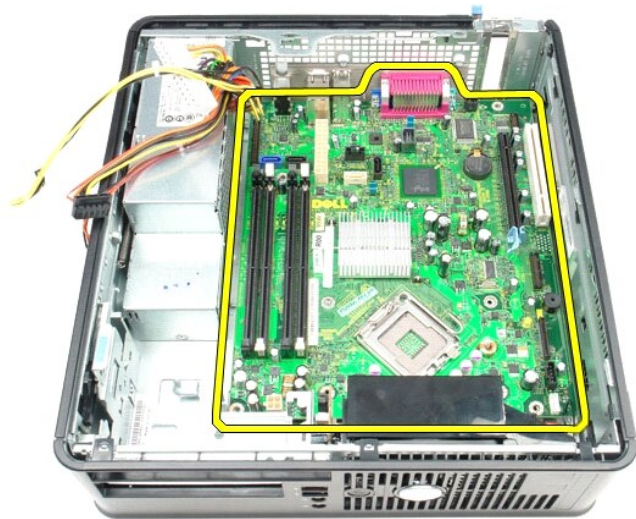

Replacing the System Board

To replace the system board, perform the above steps in reverse order.

[Back to Contents Page](#)

Working on Your Computer

Dell™ OptiPlex™ 580 Service Manual—Small Form Factor

- [Before Working Inside Your Computer](#)
- [Recommended Tools](#)
- [Turning Off Your Computer](#)
- [After Working Inside Your Computer](#)

Before Working Inside Your Computer

Use the following safety guidelines to help protect your computer from potential damage and to help to ensure your personal safety. Unless otherwise noted, each procedure included in this document assumes that the following conditions exist:

- 1 You have performed the steps in [Working on Your Computer](#).
- 1 You have read the safety information that shipped with your computer.
- 1 A component can be replaced or—if purchased separately—installed by performing the removal procedure in reverse order.

⚠ WARNING: Before working inside your computer, read the safety information that shipped with your computer. For additional safety best practices information, see the Regulatory Compliance Homepage at www.dell.com/regulatory_compliance.

⚠ CAUTION: Only a certified service technician should perform repairs on your computer. Damage due to servicing that is not authorized by Dell is not covered by your warranty.

⚠ CAUTION: To avoid electrostatic discharge, ground yourself by using a wrist grounding strap or by periodically touching an unpainted metal surface, such as a connector on the back of the computer.

⚠ CAUTION: Handle components and cards with care. Do not touch the components or contacts on a card. Hold a card by its edges or by its metal mounting bracket. Hold a component such as a processor by its edges, not by its pins.

⚠ CAUTION: When you disconnect a cable, pull on its connector or on its pull-tab, not on the cable itself. Some cables have connectors with locking tabs; if you are disconnecting this type of cable, press in on the locking tabs before you disconnect the cable. As you pull connectors apart, keep them evenly aligned to avoid bending any connector pins. Also, before you connect a cable, ensure that both connectors are correctly oriented and aligned.

📌 NOTE: The color of your computer and certain components may appear differently than shown in this document.

To avoid damaging your computer, perform the following steps before you begin working inside the computer.

- 1. Ensure that your work surface is flat and clean to prevent the cover from being scratched.
- 2. Turn off your computer (see [Turning Off Your Computer](#)).

⚠ CAUTION: To disconnect a network cable, first unplug the cable from your computer and then unplug the cable from the network device.

- 3. Disconnect all network cables from the computer.
- 4. Disconnect your computer and all attached devices from their electrical outlets.
- 5. Press and hold the power button while the computer is unplugged to ground the system board.
- 6. Remove the [cover](#).

⚠ CAUTION: Before touching anything inside your computer, ground yourself by touching an unpainted metal surface, such as the metal at the back of the computer. While you work, periodically touch an unpainted metal surface to dissipate static electricity, which could harm internal components.

Recommended Tools

The procedures in this document may require the following tools:

- 1 Small flat-blade screwdriver
- 1 Phillips screwdriver
- 1 Small plastic scribe
- 1 Flash BIOS update program media

Turning Off Your Computer

⚠ CAUTION: To avoid losing data, save and close all open files and exit all open programs before you turn off your computer.

- 1. Shut down the operating system:

- 1 In Windows Vista®:

Click **Start** , then click the arrow in the lower-right corner of the **Start** menu as shown below, and then click **Shut Down**.



- 1 In Windows® XP:

Click **Start**→ **Turn Off Computer**→ **Turn Off**.

The computer turns off after the operating system shutdown process is complete.

2. Ensure that the computer and all attached devices are turned off. If your computer and attached devices did not automatically turn off when you shut down your operating system, press and hold the power button for about 6 seconds to turn them off.

After Working Inside Your Computer

After you complete any replacement procedure, ensure you connect any external devices, cards, and cables before turning on your computer.

1. Replace the [cover](#).

 **CAUTION:** To connect a network cable, first plug the cable into the network device and then plug it into the computer.

2. Connect any telephone or network cables to your computer.
3. Connect your computer and all attached devices to their electrical outlets.
4. Turn on your computer.
5. Verify that the computer works correctly by running the Dell Diagnostics. See [Dell Diagnostics](#).

[Back to Contents Page](#)