



ADLINK
TECHNOLOGY INC.

NuPRO-860

PICMG 1.2 ePCI-X

Full-Size SBC

User's Manual

Manual Rev. 2.00
Revision Date: December 15, 2004
Part No: 50-13050-100



Recycled Paper

Advance Technologies; Automate the World.



Copyright 2004 ADLINK TECHNOLOGY INC.

All Rights Reserved.

The information in this document is subject to change without prior notice in order to improve reliability, design, and function and does not represent a commitment on the part of the manufacturer.

In no event will the manufacturer be liable for direct, indirect, special, incidental, or consequential damages arising out of the use or inability to use the product or documentation, even if advised of the possibility of such damages.

This document contains proprietary information protected by copyright. All rights are reserved. No part of this manual may be reproduced by any mechanical, electronic, or other means in any form without prior written permission of the manufacturer.

Trademarks

Product names mentioned herein are used for identification purposes only and may be trademarks and/or registered trademarks of their respective companies.

Getting Service from ADLINK

Customer Satisfaction is top priority for ADLINK Technology Inc. Please contact us should you require any service or assistance.

ADLINK TECHNOLOGY INC.

Web Site: <http://www.adlinktech.com>
 Sales & Service: Service@adlinktech.com
 TEL: +886-2-82265877
 FAX: +886-2-82265717
 Address: 9F, No. 166, Jian Yi Road, Chungho City,
 Taipei, 235 Taiwan

Please email or FAX this completed service form for prompt and satisfactory service.

Company Information	
Company/Organization	
Contact Person	
E-mail Address	
Address	
Country	
TEL	FAX:
Web Site	
Product Information	
Product Model	
Environment	OS: M/B: CPU: Chipset: Bios:

Please give a detailed description of the problem(s):

Table of Contents

List of Figures	iii
1 Introduction	1
1.1 Product Overview	1
1.2 Features.....	1
EM-64 CPU Module	1
ProCB-860 Carrier Board	2
1.3 Specifications.....	4
1.4 NuPRO-860 Mechanical Drawing.....	6
1.5 ProCB-860 Components and Connectors	7
1.6 EM-64 Functional Diagram	8
1.7 Unpacking Checklist	9
2 Connectors and Jumpers.....	11
2.1 Connector Pin Assignments	11
VGA Connector (CN1)	11
LAN RJ-45 Connector (CN2))	12
COM 1 - 4 Ports (CN5, CN6, CN8, CN10)	13
Primary/Secondary IDE connector (CN16/CN17)	14
ATX Power Connector (CN24)	15
Floppy Connector (CN9)	16
Front Panel Pin Header (CN27)	17
Parallel Port (CN7)	18
USB Pin Header (CN25)	18
FAN connectors (FN1,FN2)	19
IrDA Connector (CN15)	19
External Temperature Sensor Connector (CN11)	20
External PS/2 KB/MS Connector (CN14)	20
SATA 1, 2 Connectors (CN22, CN23)	21
AC '97 Interface (CN26)]	21
ePCI-X SHB Connector Pin Definition	22
Board-to-Board Interface Pin Definition (CN21)	24
2.2 Jumper Settings.....	26
Clear CMOS Jumper (JP1)	26
3 Getting Started	27
3.1 CPU Installation.....	27
3.2 Memory Installation.....	29

Installing the First Memory Module	29
Installing the second memory module	30
3.3 Heat Sink Installation	32
3.4 Connecting IDE Devices to the NuPRO-860	32
3.5 BIOS Configuration Overview	33
3.6 Operating System Installation	33
4 Device Driver Installation	35
4.1 Intel® 855GME/6300ESB Chipset	35
System Requirements	35
Intel® Chipset Software Installation Utility	35
4.2 VGA Driver Installation	36
4.3 LAN Driver Installation	36
4.4 Audio Codec Driver Installation	37
5 Watchdog Timer	39
5.1 WDT Overview	39
5.2 Configuration Registers	40
5.3 WDT Programming Procedure	42
5.4 WDT Utilities	42
6 ePCI-X Bus Details	43
6.1 NuPRO-860 ePCI-X Bus	43
6.2 Global Signals	43
6.3 PCI-X Bus Signals	44
Warranty Policy	45

List of Figures

Figure 1-1: NuPRO-860 Mechanical Drawing.....	6
Figure 1-2: ProCB-860 Carrier Board Layout	7
Figure 1-3: EM-64 Functional Diagram.....	8
Figure 3-1: Heat Sink Installation.....	28
Figure 3-2: CPU Installation.....	28
Figure 3-3: First Memory Module Installation.....	30
Figure 3-4: EM-64 CPU Module Removal	31
Figure 3-5: Second Memory Module Installation	31
Figure 3-6: Heat Sink Installation.....	32
Figure 5-1: WDT Block Diagram	40

1 Introduction

1.1 Product Overview

The NuPRO-860 single board computer is comprised of the ProCB-860, a PICMG 1.2 ePCI-X compliant full-size carrier board, and the EM-64 CPU module. It features a single Intel® Pentium® M processor with 1MB L2 cache in a 478-pin Micro-FCPGA package, and is validated with the Intel® 855GME chipset that supports 144-bit wide PC2100/2700 (266/333 MHz) ECC DDR DIMM up to a maximum of 2GB.

The EM-64 CPU module is a 112.4 x 94 mm embedded form factor CPU module that incorporates the 855GME Graphics Memory Controller Hub (GMCH) northbridge. By separating the northbridge and southbridge between the EM-64 CPU module and ProCB-860 carrier board, the NuPRO-860 is designed to facilitate speedy development of semi-custom designs.

The ProCB-860 carrier board is equipped with the Intel® 6300ESB I/O Controller Hub (ICH). It also includes common PC peripheral I/O interfaces such as serial and parallel ports, keyboard/mouse, Gigabit Ethernet, IDE, VGA, and AC '97 audio.

The ProCB-860 carrier board and EM-64 CPU module are connected by a proprietary high-speed interface that links the CPU and northbridge on the CPU module to the southbridge on the carrier board. It also connects the display signals such as analog RGB, LVDS LFP and DVO signals from the northbridge to the ProCB-860.

The NuPRO-860 is designed to support the following operating systems: Windows 2000, Windows XP, and Red Hat Linux 7.x

1.2 Features

EM-64 CPU Module

The following is a list of the EM-64's key features:

- ▶ A single high performance, low power Intel® Pentium® M processor with 1MB L2 cache in Micro-FCPGA packages (up to 1.7GHz).
 - ▷ Supports Intel® Architecture with Dynamic Execution.
 - ▷ High performance, low-power core.
 - ▷ On-die, primary 32-KB instruction cache and 32-KB write-back data cache.
 - ▷ On-die, 1-MB second level cache with Advanced Transfer Cache Architecture.
 - ▷ 400-MHz, Source-Synchronous processor system bus.
- ▶ 855GME Graphics Memory Controller Hub (GMCH) north-bridge.
- ▶ Supports up to two double-sided SODIMMs (four rows populated) with unbuffered PC2100/PC2700 DDR-SDRAM with or without ECC (64-bit data interface with ECC SODIMM, 72-bit with ECC SODIMM).
- ▶ Supports 64 Mb, 128 Mb, 256 Mb, and 512 Mb technologies for x8 and x16 width devices.
- ▶ Supports analog display (RGB) up to 1600 x 1200 at 85Hz, 2048 x 1536 at 75Hz; and digital display (DVO) up to 1600 x 1200 at 85Hz.
- ▶ Up to 64 MB of dynamic video memory allocation.
- ▶ CPU temperature monitoring.

ProCB-860 Carrier Board

The ProCB-860 includes the **Intel® 6300ESB ICH** that has the following functions and capabilities:

- ▶ 8-Bit Hub Interface with 266 Mbyte/s maximum throughput.
- ▶ PCI-X Specification, Revision 1.0 compliant for 64-bit/66MHz operations: Supports one PCI-X interface on PCI golden finger bus-A, and is also compliant with PCI Local Bus Specification, Revision 2.2. Throughput of PCI-X bus is up to 480 MB/s; supports 64-bit addressing on PCI-X using DAC protocol.
- ▶ PCI Local Bus Specification, Revision 2.2 compliant for 32-bit/33MHz operations: Supports one PCI interface on

PCI golden finger bus-B. Throughput of PCI bus interface is 132 MB/s; supports 44-bit addressing using DAC protocol

- ▶ Integrated IDE controller supports dual Ultra ATA 33/66/100 IDE channels; secondary IDE also supports a DB-6760CF daughter card interface to provide one CF Type I/II connector.
- ▶ Integrated Serial ATA Host Controllers: Features two sets of interface signals that may be independently enabled, tri-stated or driven low. An independent DMA controller supports each interface.
- ▶ One EHCI USB 2.0 Host Controller and two USB UHCI Host Controllers provide support for 4 USB 2.0 ports (two ports on the back panel, and two ports via onboard pin header. Over-current detection, USB legacy devices, USB devices boot feature supported on all USB ports.
- ▶ ACPI Power Management Logic Support.
- ▶ Enhanced DMA Controller, Interrupt Controller, and Timer Functions.
- ▶ System Management Bus (SMBus) Specification, v2.0 with support for I²C devices.
- ▶ Low Pin Count interface/Firmware Hub: The ProCB-860's System BIOS flash, the SST 49LF004A (4Mbit capacity), is compatible with the Intel® 82802 Firmware Hub device. BIOS write-protect function can be enabled/disabled in the BIOS option menu.
- ▶ Watchdog Timer: A 2-stage Watchdog Timer (WDT) is embedded on Hance Rapids and can be enabled/disabled via BIOS settings. Supports a selectable prescaler – approximately 1 MHz (1 us to 1 s) and approximately 1KHz (1 ms to 10 min). When the counter reaches the first preset value the WDT generates an IRQ, SMI, or SCI interrupt and loads the second preset value. When the counter reaches the second preset value it drives WDT_OUT# low and resets the ProCB-860.

Other features of the **ProCB-860** include:

- ▶ The Intel® 82541GI single port **Gigabit Ethernet Controller** supports one gigabit Ethernet (GbE) port which is connected

to the rear I/O panel. The 82541GI enables offloading of tasks such as TCP/UDP/IP checksum calculations from the host processor, handles all IEEE 802.3 receive and transmit MAC functions, and contains fully integrated PHY circuitry for 1000 Base-T, 100 Base-TX, and 10 Base-T (IEEE 802.3, 802.3u, and 802.3ab) applications, provides an integrated dual-port solution comprised of two distinct MAC/PHY instances, and appears as a multi-function PCI device.

- ▶ **Hardware Monitor:** The W83627HF monitors critical hardware parameters, including system and CPU voltages and temperature. All hardware health status can be accessed from the BIOS options menu, and runtime utilities. In addition, once the preset thresholds of hardware conditions are met, the W83627HF will alert the system or reset the system in critical situations.

1.3 Specifications

NuPRO-860 Specifications	
Carrier Board	ProCB-860
CPU	Single Intel® Pentium® M Processor 1M L2 cache, 400MHz FSB, 1.1 to 1.6 GHz
System Memory	ECC DDR SDRAM, So-DIMM x2 2GB maximum
Chipset	Intel® 855GME Graphic Memory Controller Hub Intel® 6300ESB I/O Controller Hub
Hardware Monitor	Analog Device® ADM-1032 Winbond® W83627HF
LAN	Intel® 82541GI single port gigabit Ethernet controller
Display Interface	Analog CRT output on back panel I/O, supports 1600x1200 at 85Hz refresh and 2048x1536 at 75Hz refresh.
	One DVI interface supports up to 165M pixels/sec, resolutions up to 1600x1200 UXGA display.
	One channel LFP transmitter interface to support LVDS LCD panel resolutions up to UXGA.

Table 1-1: NuPRO-860 Specifications

NuPRO-860 Specifications	
Back panel I/O	10/100/1000Mbps LAN x 1 USB 2.0 x 2 VGA x 1
BIOS	Award/Phoenix
USB	Two USB 2.0 ports on back panel Two USB 2.0 ports via onboard pin header
I/O Connectors	SATA x2
	IEEE-1284 Printer Port x1
	RS-232 Serial Ports x4
	6-pin PS/2 keyboard/mouse interface pin header
	34 pin floppy interface pin header, supports 2 floppy devices.
	AC '97 interface
Watchdog Timer	Built into 6300ESB, programmable I/O port to configure Watchdog Timer, programmable timer 1~255 seconds or 1~255 minutes
Dimension	338mm x 122mm
Operating Temp.	0 to 60°C
Humidity	5% to 95% non-condensed
Operating System	Microsoft® Windows 2000, Windows XP, Windows eXP, Red Hat Linux 9.x. Other OS support upon request.
Safety Certificates and Tests	CE, FCC Class A

Table 1-1: NuPRO-860 Specifications

1.4 NuPRO-860 Mechanical Drawing

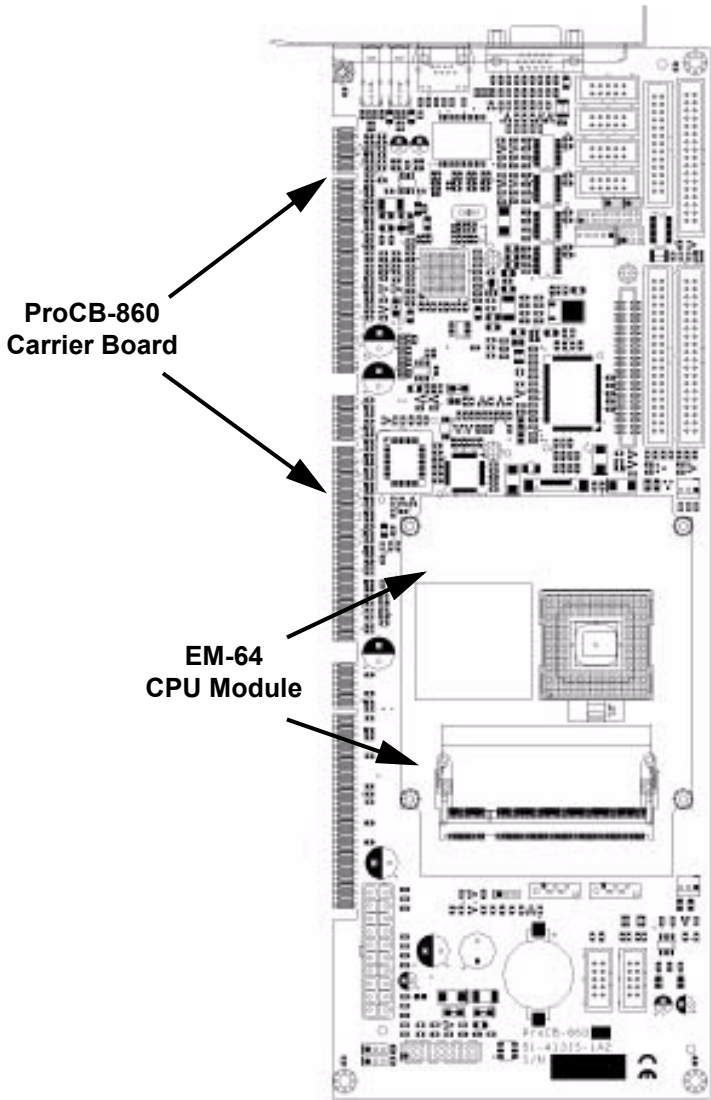

Figure 1-1: NuPRO-860 Mechanical Drawing

1.5 ProCB-860 Components and Connectors

A	6300ESB
B	GigaLan (82541)
C	FWH (BIOS)
D	Connector to EM-64 (CN21)
E	Primary-IDE (CN16)
F	Secondary-IDE (CN17)
G	CF Interface (CN18) (Secondary-IDE)
H	Super IO (83627HF)
I	LVDS LFP connector (CN20)
J	Ext. Temp Sensor (CN11) DVI connector (CN13)
K	PS/2 KB/MS (CN14)
L	IrDA connector (CN15)
M	COM1~4 (CN5,6,8,10)
N	Parallel port connector (CN7)
O	Floppy connector (CN9)
P	USB pin header (CN25)
Q	AC '97 interface (CN26)
R	RTC battery
S	Buzzer
T	ATX connector (CN24)
U	SATA 0, 1 (CN22,23)
V	Clear CMOS jumper (JP1)
W	Front Panel Pin Connector (CN27)
X	VGA connector (CN1)
Y	LAN RJ-45 connector (CN2)
Z	USBx2 (CN3,4)

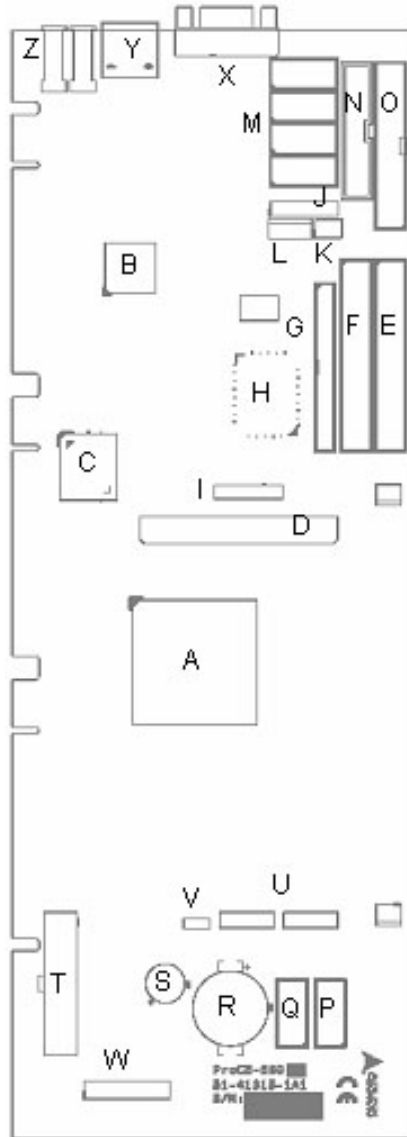

Figure 1-2: ProCB-860 Carrier Board Layout

1.6 EM-64 Functional Diagram

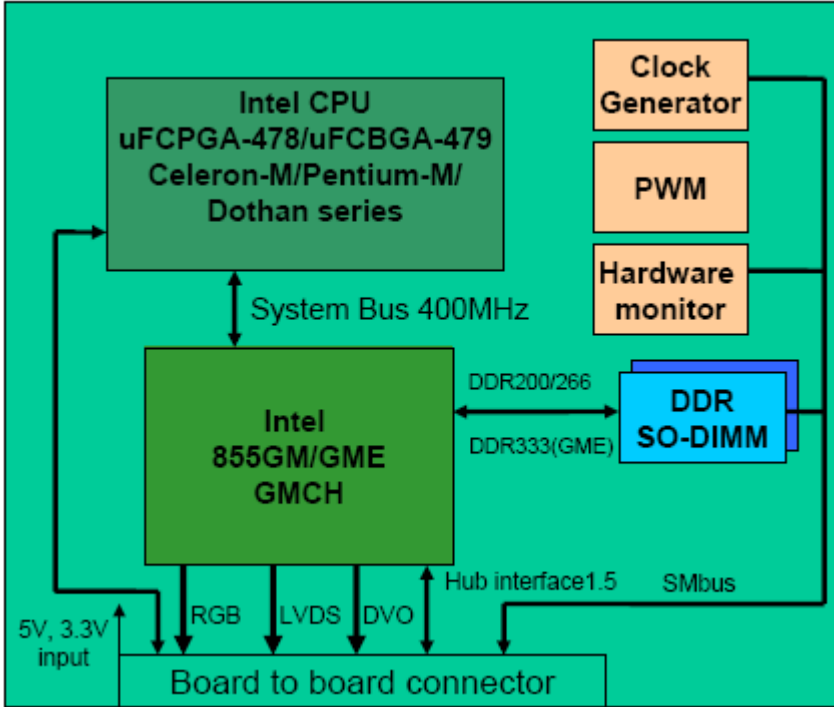

Figure 1-3: EM-64 Functional Diagram

1.7 Unpacking Checklist

Check the shipping carton for any damage. If the shipping carton and contents are damaged, notify the dealer for a replacement. Retain the shipping carton and packing materials for inspection by the dealer. Obtain authorization before returning any product to ADLINK.

Check the following items are included in the package, if there are any items missing, please contact your dealer:

Included Items
ProCB-860 carrier board with EM-64 CPU module
COM port cable bracket
ATA-100 cables (x2)
DVI cable
ADLINK All-in-One CD-ROM
This User's Manual

Note: The packaging of the NuPRO-860 OEM version with non-standard configuration, functionality, or package may vary according to different configuration requests.

CAUTION: The NuPRO-860 single board computer must be protected from static discharge and physical shock. Never remove any of the socketed parts except at a static-free workstation. Use the anti-static bag shipped with the product to handle the board. Wear a grounded wrist strap when servicing



2 Connectors and Jumpers

This chapter will familiarize the user with the connectors and jumpers on the NuPRO-860. Please refer to **Figure 1-2: ProCB-860 Carrier Board Layout** for connector and jumper locations.

2.1 Connector Pin Assignments

VGA Connector (CN1)

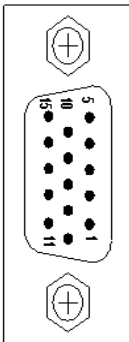

Pin	Signal	Function
1	Red	Analog RED
2	Green	Analog GREEN
3	Blue	Analog BLUE
4	N/C	No Connect
5	GND	Ground
6	GND	Ground
7	GND	Ground
8	GND	Ground
9	+5V	Ground
10	GND	Ground
11	N/C	No connect
12	DDCDAT	DDC Data for CRT
13	HSYNC	Horizontal sync for Monitor
14	VSYNC	Vertical sync for Monitor
15	DDCCLK	DDC CLK for CRT

LAN RJ-45 Connector (CN2)

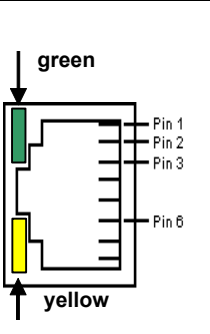
	Pin	Signal	Function
	1	LAN2_TDP1	Transmit Data1 +
	2	LAN2_TDN1	Transmit Data1 -
	3	LAN2_RDP2	Receive Data2 +
	4	LAN2_RDP3	Receive Data3 +
	5	LAN2_RDN3	Receive Data3 -
	6	LAN2_RDN2	Receive Data2 -
	7	LAN2_TDP4	Transmit Data4 +
8	LAN2_TDN4	Transmit Data4 -	

LED Color	Status	Function
Green (speed)	ON	1000Mbps
	OFF	100Mbps
Yellow (link)	ON	Link
	OFF	Link off
	blinking	Data transfer in progress

COM 1 - 4 Ports (CN5, CN6, CN8, CN10)

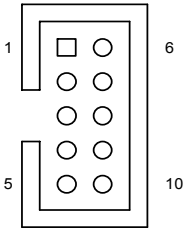

Pin	Signal	Function
1	DCD	Data Carrier Detect
2	RXD	Receive Data
3	TXD	Transmit Data
4	DTR	Data Terminal Ready
5	GND	Ground
6	DSR	Data Set Ready
7	RTS	Request to Send
8	CTS	Clear to Send
9	RI	Ring Indicate
10	NC	No Connect

Primary/Secondary IDE connector (CN16/CN17)

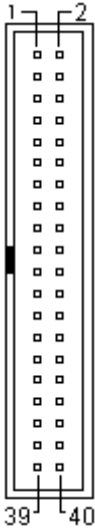

Signal	Pin	Pin	Signal
Reset IDE	1	2	Ground
Host data 7	3	4	Host data 8
Host data 6	5	6	Host data 9
Host data 5	7	8	Host data 10
Host data 4	9	10	Host data 11
Host data 3	11	12	Host data 12
Host data 2	13	14	Host data 13
Host data 1	15	16	Host data 14
Host data 0	17	18	Host data 15
Ground	19	20	No connect
DRQ0 / DRQ1	21	22	Ground
Host IOW	23	24	Ground
Host IOR	25	26	Ground
IOCHRDY	27	28	Host ALE
DACK0 / DACK1	29	30	Ground
IRQ14 / IRQ 15	31	32	No connect
Address 1	33	34	No connect
Address 0	35	36	Address 2
Chip select 0	37	38	Chip select 1
Activity	39	40	Ground

ATX Power Connector (CN24)

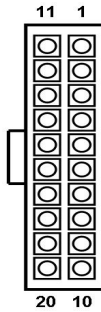

Pin	Signal	Pin	Signal
1	+3.3V	11	+3.3V
2	+3.3V	12	-12V
3	GND	13	GND
4	+5V	14	PS_ON#
5	GND	15	GND
6	+5V	16	GND
7	GND	17	GND
8	PWRGOOD	18	-5V
9	STB5V	19	+5V
10	+12V	20	+5V

Floppy Connector (CN9)

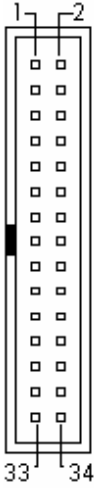

Signal	Pin	Pin	Signal
Ground	1	2	Drive density selection
Ground	3	4	No connect
Ground	5	6	Drive density selection
Ground	7	8	Index
Ground	9	10	Motor enable 0
Ground	11	12	Drive select 1
Ground	13	14	Drive select 0
Ground	15	16	Motor enable 1
Ground	17	18	Direction
Ground	19	20	Step
Ground	21	22	Write data
Ground	23	24	Write gate
Ground	25	26	Track 00
Ground	27	28	Write protect
Ground	29	30	Read data
Ground	31	32	Side 1 select
Ground	33	34	Diskette change

Front Panel Pin Header (CN27)

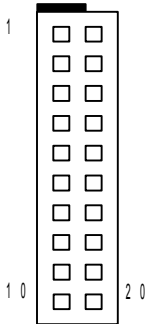

Pin	Signal	Function	Pin Group
1	+5V	Power	Power LED
2	WDTLED#	Watchdog LED Signal	
3	PLED	Power LED Signal	
4	KEYLOCK	Keyboard lock	Key Lock
5	GND	Ground	ATX Power Connector
6	GND	Ground	
7	NC	No connect	
8	PWRON	Power-on signal	
9	+5VSB	Standby Power	
10	PME#	Power Management Event	Chassis Speaker
11	WDSPK	Speaker signal	
12	NC	No connect	
13	NC	No connect	RESET button
14	+5V	Power	
15	RESETBT	RESET Button signal	Hard Disk LED
16	GND	Ground	
17	HDDLED	Hard Disk LED signal	Power on button
18	+5V	Power	
19	PWRBT	POWER Button signal	Power on button
20	GND	Ground	

Parallel Port (CN7)

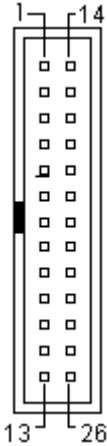

Signal	Pin	Pin	Signal
Line printer strobe	1	14	AutoFeed
PD0, parallel data 0	2	15	Error
PD1, parallel data 1	3	16	Initialize
PD2, parallel data 2	4	17	Select
PD3, parallel data 3	5	18	Ground
PD4, parallel data 4	6	19	Ground
PD5, parallel data 5	7	20	Ground
PD6, parallel data 6	8	21	Ground
PD7, parallel data 7	9	22	Ground
ACK, acknowledge	10	23	Ground
Busy	11	24	Ground
Paper empty	12	25	Ground
Select	13	N/A	N/A

USB Pin Header (CN25)

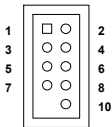

Pin	Signal	Signal	Pin
1	VCC	VCC	2
3	USBP2N	USBP3N	4
5	USBP2P	USBP3P	6
7	GND	GND	8
9	—	NC	10

FAN connectors (FN1,FN2)

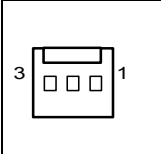
	Pin	Signal
	1	FAN speed
	2	Fan power
	3	GND

IrDA Connector (CN15)



Pin	Signal
1	+3.3V
2	not connected
3	IrRXD
4	Ground
5	IrTXD

External Temperature Sensor Connector (CN11)



Pin	Signal	Function
1	TSEN_I	Thermal resistor input
2	TSEN_G	Thermal resistor ground

External PS/2 KB/MS Connector (CN14)

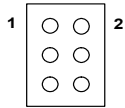

Pin	Signal
1	Keyboard data
2	Keyboard clock
3	Mouse data
4	Mouse clock
5	+5V
6	GND

SATA 1, 2 Connectors (CN22, CN23)



Pin	Signal
1	GND
2	Tx+
3	Tx-
4	GND
5	Rx-
6	Rx+
7	GND

AC '97 Interface (CN26]

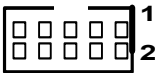

Signal	Pin	Pin	Signal
GND	1	2	AC_CLK
GND	3	4	AC_SDIN0
+5V	5	6	AC_SDOUT
+5V	7	8	AC_SDIN1
AC_SYNC	9	10	AC_RSTJ

ePCI-X SHB Connector Pin Definition

P1 Connector			P2 Connector			P3 Connector		
Pin	Side B	Side A	Pin	Side B	Side A	Pin	Side B	Side A
1	-12V	+12V	1	GND	a_AD04	1	b_VIO	b_AD22
2	PWRGD	PWRBT#	2	a_AD05	+3.3V	2	b_C/BE3#	GND
3	PSO#	+5Vaux	3	a_AD03	a_AD02	3	b_AD23	b_AD21
4	TRST#	GND	4	GND	a_AD00	4	+5V	b_AD20
5	TMS	TCK	5	a_AD01	GND	5	b_AD19	GND
6	TDO	TDI	6	Reserved	a_REQ6#	6	b_AD17	b_AD18
7	Reserved	a_PRSNT#	7	+5V	a_ACK64#	7	GND	b_AD16
8	+5V	Reserved	8	Reserved	+5V	8	b_C/BE2#	+3.3V
9	a_INTB#	+5V	9	a_VIO	a_C/BE7#	9	b_IRDY#	b_FRAME#
10	a_INTD#	a_INTA#	10	GND	a_C/BE6#	10	GND	b_TRDY#
11	+5V	a_INTC#	11	a_C/BE5#	GND	11	b_DEVSEL#	GND
12	Key	Key	12	Key	Key	12	Key	Key
13	Key	Key	13	Key	Key	13	Key	Key
14	+3.3Vaux+	+5V	14	a_C/BE4#	a_PAR64	14	+5V	b_PCIXCAP
15	GND	Reserved	15	+5V	a_AD62	15	b_LOCK#	b_STOP#
16	Reserved	a_GNT3#	16	a_AD63	GND	16	b_PERR#	GND
17	+3.3V	GND	17	a_AD61	a_AD60	17	GND	b_PAR
18	a_REQ3#	a_GNT2#	18	GND	a_AD58	18	b_SERR#	b_AD15
19	a_REQ2#	a_GNT1#	19	a_AD59	+3.3V	19	b_C/BE1#	+3.3V
20	GND	+3.3V	20	a_AD57	a_AD56	20	GND	b_AD13
21	a_REQ1#	a_RST#	21	GND	a_AD54	21	b_AD14	b_AD11
22	a_REQ0#	a_GNT0#	22	a_AD55	GND	22	b_AD12	GND
23	+3.3V	GND	23	a_AD53	a_AD52	23	+5V	b_AD09
24	a_CLKFO	a_CLKFI	24	+5V	a_AD50	24	b_AD10	b_M66EN
25	GND	+3.3V	25	a_AD51	GND	25	b_AD08	GND
26	a_CLKC	a_CLKD	26	a_AD49	a_AD48	26	GND	b_C/BE0#
27	+3.3V	GND	27	GND	a_AD46	27	b_AD07	b_AD06
28	a_CLKA	a_CLKB	28	a_AD47	+3.3V	28	b_AD05	+3.3V
29	GND	+3.3V	29	a_AD45	a_AD44	29	GND	b_AD04
30	a_AD31	PME#	30	GND	a_AD42	30	b_AD03	b_AD02
31	a_AD29	GND	31	a_AD43	GND	31	b_AD01	GND
32	+5V	a_AD30	32	a_AD41	a_AD40	32	+5V	b_AD00
33	a_AD27	a_AD28	33	+5V	a_AD38	33	b_ACK64#	b_REQ64#
34	a_AD25	GND	34	a_AD39	GND	34	b_C/BE7#	GND

P1 Connector			P2 Connector			P3 Connector		
Pin	Side B	Side A	Pin	Side B	Side A	Pin	Side B	Side A
35	GND	a_AD26	35	a_AD37	a_AD36	35	GND	b_C/BE6#
36	a_C/BE3#	a_AD24	36	GND	a_AD34	36	b_C/BE5#	b_PAR64
37	a_AD23	+3.3V	37	a_AD35	+3.3V	37	b_C/BE4#	+3.3V
38	GND	a_AD22	38	a_AD33	a_AD32	38	GND	b_AD62
39	a_AD21	a_AD20	39	GND	GND	39	b_AD63	b_AD60
40	a_AD19	GND	40	b_ACLKD	b_CLKC	40	b_AD61	GND
41	+5V	a_AD18	41	+3.3V	GND	41	+5V	b_AD58
42	a_AD17	a_AD16	42	b_CLKB	b_CLKA	42	b_AD59	b_AD56
43	a_C/BE2#	GND	43	GND	+3.3V	43	b_AD57	GND
44	GND	a_FRAME#	44	b_CLKFO	b_CLKFI	44	GND	b_AD54
45	a_IRDY#	a_TRDY#	45	GND	GND	45	b_AD55	b_AD52
46	a_DEVSEL#	+5V	46	b_INTB#	b_INTA#	46	b_AD53	+3.3V
47	+3.3V	a_PCIXCAP	47	b_INTD#	b_NTC#	47	GND	b_AD50
48	a_LOCK#	a_STOP#	48	+5V	GND	48	b_AD51	b_AD48
49	a_PERR#	GND	49	b_GNT3#	b_GNT2#	49	b_AD49	GND
50	+5V	SER_SDA	50	b_REQ3#	b_REQ2#	50	+5V	b_AD46
51	a_SERR#	SER_SCL	51	GND	+5V	51	b_AD47	b_AD44
52	a_PAR	GND	52	b_GNT1#	b_GNT0#	52	b_AD45	GND
53	GND	a_C/BE1#	53	b_REQ1#	b_REQ0#	53	GND	b_AD42
54	a_AD15	a_AD14	54	+5V	GND	54	b_AD43	b_AD40
55	a_AD13	+3.3V	55	b_RST#	b_PRSNT#	55	b_AD41	+3.3V
56	GND	a_AD12	56	+5V	b_AD30	56	GND	b_AD38
57	a_AD11	a_AD10	57	b_AD31	GND	57	b_AD39	b_AD36
58	a_AD08	GND	58	b_AD29	b_AD28	58	b_AD37	GND
59	+5V	a_AD09	59	GND	b_AD26	59	+5V	b_AD34
60	a_AD07	a_C/BE0#	60	b_AD27	+3.3V	60	b_AD35	b_AD32
61	a_M66EN	GND	61	b_AD25	b_AD24	61	b_AD33	GND
62	Reserved	a_AD06	62	GND	Reserved	62	GND	Reserved

Board-to-Board Interface Pin Definition (CN21)

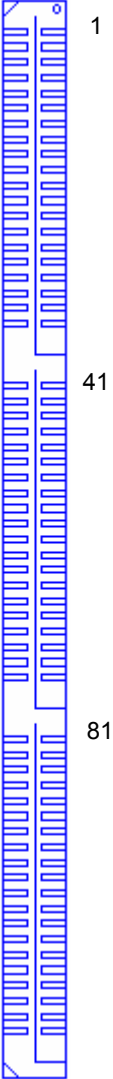

Segment 1 (Metal Plane: GND)			
Signal	Pin	Pin	Signal
GND	1	2	GND
DVOD0	3	4	HI_HL10
DVOD1	5	6	HI_HL9
DVOD2	7	8	GND
VCCP	9	10	HI_HL8
DVOD3	11	12	HI_HL7
DVOD4	13	14	GND
DVOD5	15	16	HI_HL6
GND	17	18	HI_HL5
DVOD6	19	20	GND
DVOD7	21	22	HI_HL4
DVOD8	23	24	HI_HL3
+3.3V	25	26	GND
DVOD9	27	28	HI_HL2
DVOD10	29	30	HI_HL1
DVOD11	31	32	HI_HL0
GND	33	34	GND
DVOCCLK	35	36	HI_STB
DVOCCLK#	37	38	HI_STB#
DVOCINT	39	40	Vcore
Segment 2 (Metal Plane: 3.3V)			
Signal	Pin	Pin	Signal
3.3V	41	42	3.3V
DVOHSYNC	43	44	CLK66
DVOVSYNC	45	46	GND
DVOBLK#	47	48	GVSYSNC
GND	49	50	GHSYSNC
ICLKAP	51	52	GRED
ICLKAM	53	54	GGREEN
3.3V	55	56	GBLUE
IYAP3	57	58	GND
IYAM3	59	60	HCK100
GND	61	62	GND
IYAP2	63	64	HCK100#
IYAM2	65	66	3.3V
GND	67	68	CLK48

IYAP1	69	70	GND
IYAM1	71	72	CLK33
GND	73	74	GND
IYAP0	75	76	CLK14
IYAM0	77	78	GND
ADDCDATA	79	80	CLK33_2
Segment 3 (Metal Plane: GND)			
Signal	Pin	Pin	Signal
ADDCCCLK	81	82	PCIRSTJ
5V	83	84	HIGNNE#
HSMI#	85	86	HNMI
HFERR#	87	88	PWROK_MCH
CPUSLP#	89	80	CPUPWGD
5V	91	92	5V
DPRSLPVR	93	94	SMD_SYS
DPSLP#	95	96	SMC_SYS
TMDS_I2CC	97	98	5V
TMDS_I2CD	99	100	MI2CDATA
5V	101	102	MI2CCLK
THERTRIP#	103	104	5V
VRPWRGD	105	106	HINIT#
HA20M#	107	108	THERMALART#
5V	109	110	HSTPCLK#
HDBR#	111	112	5V
HINTR	113	114	SUSCLK
5V	115	116	+12V
SLP_S3#	117	118	SLP_S4#
Reserve1	119	120	Reserve2

2.2 Jumper Settings

Clear CMOS Jumper (JP1)

The ProCB-860 has a clear CMOS jumper on the front of the board to allow the user to clear CMOS values to default values if necessary. To clear the CMOS values, apply a mini jumper to short the pins 2 and 3.



Jumper	Status
1-2	Normal
2-3	Clear CMOS

3 Getting Started

This chapter gives a summary of what is required to set up an operating system using the NuPRO-860. Hardware installation and BIOS setup are also discussed. Note that the NuPRO-860 is shipped with CPU, and RAM preinstalled. Installation of the CPU and RAM are performed at the ADLINK factory and the procedures described in the following sections are for user reference. If the default configuration does not suit your application needs, contact a local ADLINK dealer for special configurations or OEM versions.

3.1 CPU Installation

The NuPRO-860 supports the Intel® Pentium® M processors. If the required CPU module is pre-installed when the product is received, this section may be skipped.

First remove the heatsink from the EM-64 CPU Module by removing the four screws as shown in **Figure 3.1: Heat Sink Installation**. Replace the screws to secure the EM-64 CPU Module to the carrier board.

The CPU socket is located on the EM-64 CPU Module as shown in **Figure 3.2: CPU Installation** below. Remove the CPU from its packaging and place it carefully in the CPU socket as shown. Be sure to align the gold triangle on the corner of the chip with the corner of the socket that is missing a pin. Press down gently on the chip to ensure that it is securely in place, and then use a small flathead screwdriver to rotate the CPU lock clockwise and lock the CPU into position.

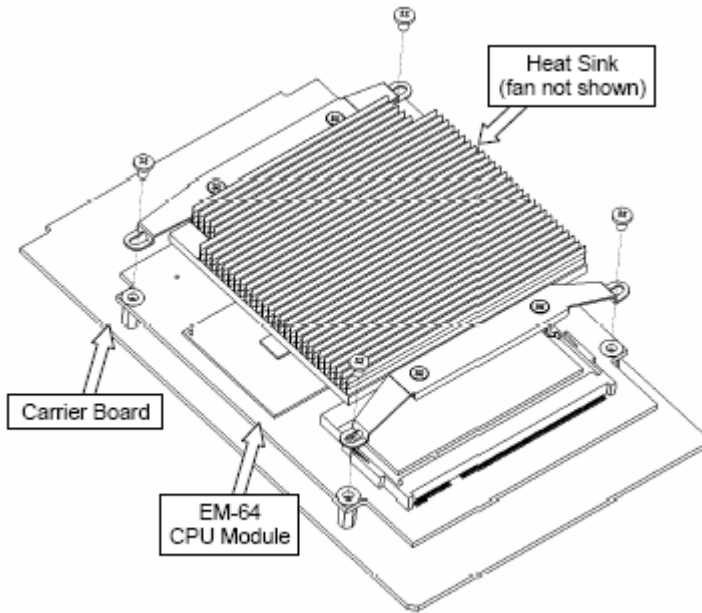

Figure 3-1: Heat Sink Installation

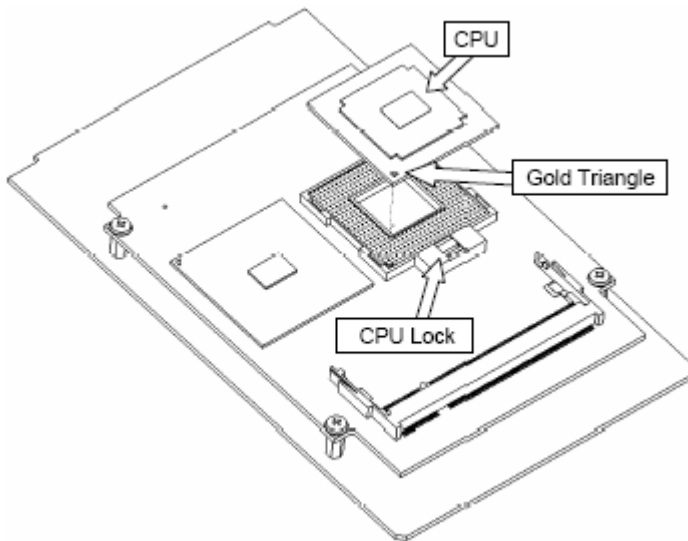

Figure 3-2: CPU Installation

3.2 Memory Installation

The NuPRO-860 CPU Module supports 200-pin PC2100/PC2700 registered/unregistered ECC DDR SDRAM up to 2GB maximum. Two memory sockets are located on the CPU Core Module (one on each side). If the required memory modules are pre-installed when the product is received, this section may be skipped.

At least one memory module will be installed in the upper DIMM slot of the NuPRO-860 when shipped. You can upgrade the amount of RAM by changing the existing memory module, or by adding a second SDRAM module. It is necessary to disassemble the NuPRO-860's EM-64 CPU Module assembly to install an SDRAM module in either of the sockets, so we recommend that users have the required SDRAM installed professionally by ADLINK.

The following list of memory modules has been tested for compatibility with the NuPRO-860. The table outlines the combinations of memory modules that have been tested on the NuPRO-860.

- M1:** Transcend 256 MB DDR266 SODIMM
- M2:** ATP AT64L64U8BFB3S 512MB PC2700 SODIMM
- M3:** UNIGEN 512 MB DDR333 SODIMM (UG064D6688LR-DH)
- M4:** UNIGEN 256 MB DDR333 SODIMM (UG032D7488KP-DH)

DIMM Slot1	DIMM Slot2	Total Size
M1	M2	768MB
M1	M3	768MB
M1	M4	512MB
M2	M3	1024MB
M2	M4	768MB
M3	M4	768MB

Installing the First Memory Module

Remove the heatsink as described in **Section 3.1 CPU Installation** above. Insert the module into the upper DIMM slot at a 30 degree angle and push the module firmly but gently downwards into the slot until the security latches on the sockets have locked into place on each side of the module (refer to **Figure 3.3: First**

Memory Module Installation). There is an alignment key on the memory module to assist users with installation.

Note: Ensure that the CPU socket is in the locked position, otherwise the memory module will not seat properly.

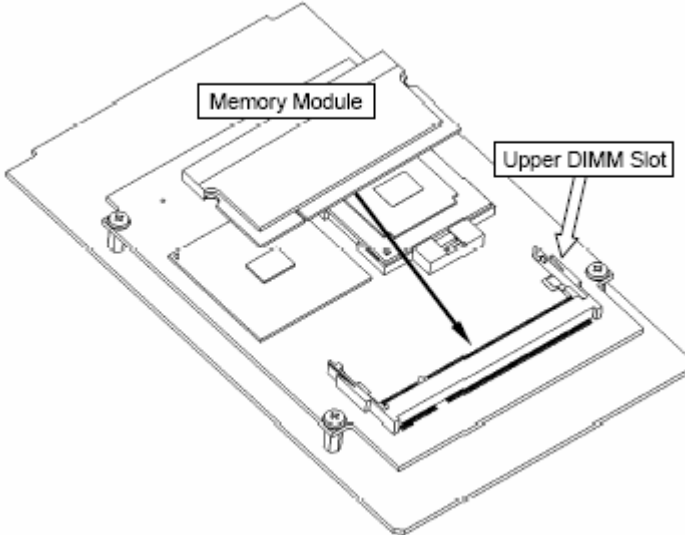

Figure 3-3: First Memory Module Installation

Installing the second memory module

Carefully remove the EM-64 CPU Module from the Carrier Board by removing the mounting screws and lifting it at the end nearest the board-to-board connector as shown in **Figure 3.4: EM-64 CPU Module Removal**. Insert the second memory module into the lower DIMM slot on the underside of the Main Board as shown in **Figure 3.5: Second Memory Module Installation** below using the same procedure as described above. Re-attach the CPU Module to the carrier board by aligning the two halves of the board-to-board connector and pressing down firmly on the CPU Module at the end nearest the connector.

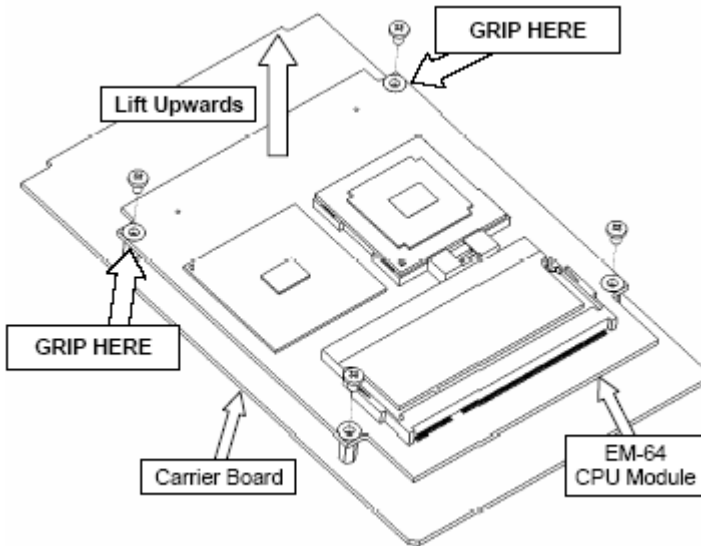

Figure 3-4: EM-64 CPU Module Removal

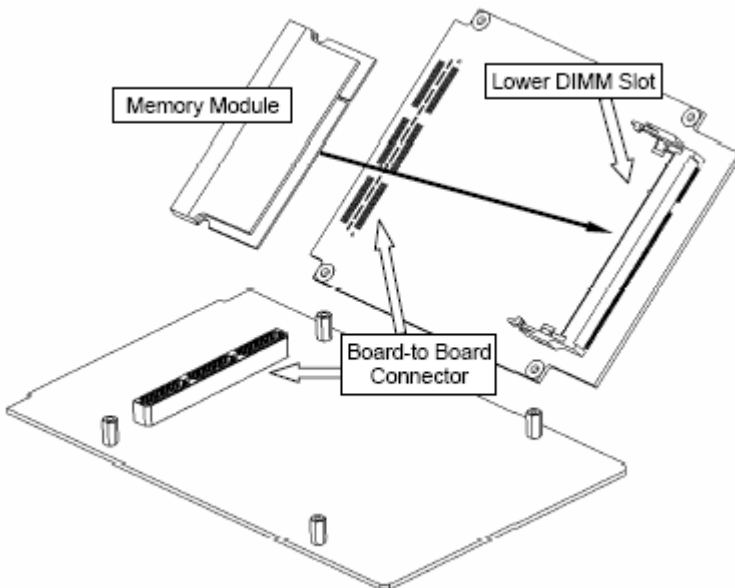

Figure 3-5: Second Memory Module Installation

3.3 Heat Sink Installation

After you have finished installing the CPU and/or memory modules, replace the heat sink by replacing the four mounting screws. Be sure that the raised blocks on the underside of the heat sink are aligned with the CPU and northbridge on the EM-64 CPU Module (refer to **Figure 3-6: Heat Sink Installation** below).

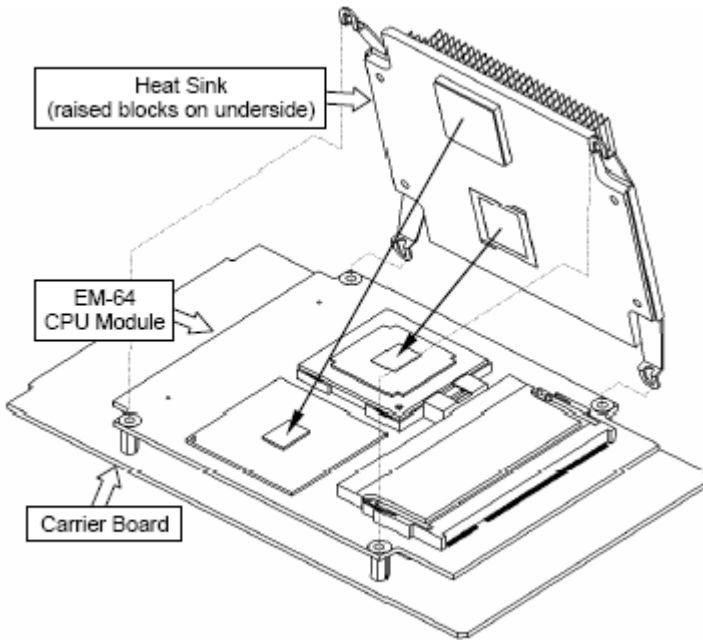

Figure 3-6: Heat Sink Installation

3.4 Connecting IDE Devices to the NuPRO-860

The NuPRO-860 supports two IDE channels, Primary and Secondary. It has two IDE device connectors onboard supporting IDE devices running in any data transfer mode up to ATA-100. Each IDE connector supports two drives, a Master and a Slave. The drives connect to the NuPRO-860 with an IDE ribbon cable.

To install an IDE drive, power down the system, connect the drive to one of the drive connectors of a suitable ribbon cable. Plug the board end of the cable into one of the IDE connectors on the

NuPRO-860. Make sure Pin 1 of the ribbon cable connector is aligned with Pin 1 of the IDE device connector.

3.5 BIOS Configuration Overview

This section gives an introduction to the Phoenix/Award Plug and Play BIOS Setup Utility.

The BIOS has many separately configurable features. These features are selected by running the built-in Setup utility. System configuration settings are saved in a portion of the battery-backed RAM in the real-time clock device and are used by the BIOS to initialize the system at boot up or reset. The configuration is protected by a checksum word for system integrity.

To access the Setup utility, press the "Del" key during system RAM check at boot time. When Setup runs, an interactive configuration screen displays.

Setup parameters are divided into different categories. The available categories are listed in a menu. The parameters of the highlighted (current) category are listed in the bottom portion of the Setup screen. Context sensitive help is displayed in the right portion of the screen for each parameter.

Use the arrow keys to select a category from the menu. To display a submenu, highlight the category and then press the "Enter" key.

3.6 Operating System Installation

For more detailed information about your operating system, refer to the documentation provided by the operating system vendor.

Installing peripheral devices: NuPRO devices are automatically configured by the BIOS during the boot sequence.

Most operating systems require initial installation on a hard drive from a floppy or CDROM drive. These devices should be configured, installed, and tested with the supplied drivers before attempting to load the new operating system.

Read the release notes and installation documentation provided by the operating system vendor. Be sure to read any README

files or documents provided on the distribution disks, as these typically note documentation discrepancies or compatibility problems.

Select the appropriate boot device order in the BIOS Setup Utility boot menu depending on the OS installation media used. For example, if the OS includes a bootable installation floppy, select Floppy as the first boot device and reboot the system with the installation floppy installed in the floppy drive. (Note that if the installation requires a non-bootable CD-ROM, it is necessary to boot an OS with the proper CD-ROM drivers in order to access the CD-ROM drive).

Proceed with the OS installation as directed. Be sure to select appropriate device types if prompted. Refer to the appropriate hardware manuals for specific device types and compatibility modes of ADLINK NuIPC products.

When installation is complete, reboot the system and set the boot device order in the Setup Utility boot menu appropriately.

4 Device Driver Installation

To install drivers for the NuPRO-850, refer to the installation information in this chapter. Basic driver installation information for Windows XP/2000 is outlined in this section. The drivers are located in the following directories of the CD-Rom:

Chipset driver	X:\NuPRO\NuPRO-860\chipset\
VGA driver	X:\NuPRO\NuPRO-860\VGA\
LAN driver	X:\NuPRO\NuPRO-860\LAN\
Audio driver	X:\NuPRO\NuPRO-860\Audio\

4.1 Intel® 855GME/6300ESB Chipset

This section describes the installation procedure for the Intel® 855GME/6300ESB chipset device driver under Windows 2000/XP.

System Requirements

One of the following operating systems must be fully installed on the system before installing any other driver, utilities, or software:

- ▶ Windows® 2000
- ▶ Windows® XP

Intel® Chipset Software Installation Utility

This section describes how to install the *Intel® Chipset Software Installation Utility* on a system running Windows 2000/XP.

1. Check the System Requirements. Windows 2000/XP must be fully installed and running on the system prior to running this software.
2. Close any running applications.
3. Place the ADLINK CD into the CD-ROM drive. Run **infinst_enu6011002.exe** under **X:\NuPRO\NuPRO-860\chipset**, where X is the CD drive letter.

4. Click **Next** on the *Welcome* screen to read and agree to the license agreement. Click **Yes** if you agree to continue. NOTE: If you click **No**, the program will terminate.
5. Click **Next** on the *Readme Information* screen to install the INF files.
6. Click **Finish** to restart the system when prompted to do so.
7. Follow the screen instructions and use the default settings to complete setup when Windows 2000/XP restarts. Upon restart, Windows may display that it has found new hardware and is installing drivers for them. Select **Yes**, if prompted to restart Windows 2000/XP. This completes the installation of the *Intel® Chipset Software Installation Utility*.

4.2 VGA Driver Installation

Windows 2000/XP will attempt to install a standard VGA driver automatically. To guarantee compatibility, manually install the most up-to-date VGA driver, which is provided on the ADLINK CD. After installing Windows 2000/XP, install the most up-to-date driver by following these steps:

1. Boot Windows 2000/XP, then run the program **X:\NuPRO\NuPRO-860\VGA\win2k_xp142.exe**, where X is the CD drive letter.
2. The VGA driver will automatically be installed onto the system.
3. Restart the system.

4.3 LAN Driver Installation

This section describes the LAN driver installation process for the **Intel® 82541GI Gigabit Ethernet Controller** under Windows 2000/XP. The Intel® software utilities package include a Diagnostics Utility, Makedisk Utility, and the 10/100/1000Mbps Ethernet device drivers. All drivers and utilities are stored in the ADLINK CD under the directory: **X:\NuPRO\NuPRO-860\LAN**, where X is the

CD drive letter. For driver installations under other operating systems, please refer to the the ADLINK CD.

During Windows 2000/XP installation, the operating system will install a LAN driver automatically. To guarantee compatibility, manually install the most up-to-date driver, which is provided on the ADLINK CD. After installing the OS, update the driver by following these steps:

1. Run the self-extracting file **pro2kxpm.exe** in the following directory:**X:\NuPRO\NuPRO-860\LAN**.
2. Click through the subsequent pages to extract the files to the default location **c:\Intel9.1**
3. Click **Install Software** to install the Intel® PRO Network Connections drivers.

4.4 Audio Codec Driver Installation

This section describes the driver installation for the AC '97 audio codec.

The driver is included on the ADLINK CD. Run **wdm_a357.exe** located in the following directory: **X:\NuPRO\NuPRO-860\Audio**.

1. Boot Windows 2000/XP, then run the program **X:\NuPRO\NuPRO-860\Audio\wdm_a357.exe**, where X is the CD driver letter.
2. Click **Next** on the *Welcome* screen to install driver..
3. Click **Finish** to restart the system.

5 Watchdog Timer

The operation of the NuPRO-860's Watchdog Timer is described in this chapter. An overview of the watchdog operation and features, as well as the programming procedure is provided to give the user an insight into the workings of the Watchdog Timer.

5.1 WDT Overview

The primary function of the Watchdog Timer is to monitor the NuPRO-860's operation and to generate an IRQ or to reset the system should the software fail to function as programmed. The major features of the Watchdog Timer are:

- ▶ Enabled and disabled through software control
- ▶ Armed and strobed through software control

The NuPRO-860's custom Watchdog Timer circuit is integrated into the south bridge 6300ESB and supports multiple modes: WDT and free-running. Free-running mode is a one stage timer and it will toggle WDT_TOUT# after a programmable time. WDT mode is a two stage timer and its operation is described as follows:

WDT Mode:

The two-stage Watchdog Timer (WDT) provides a resolution ranging from 1 micro second to 10 minutes. The timer uses a 35-bit down-counter. The counter is loaded with the value from the first Preload register. The timer is then enabled and starts counting down. The time at which the WDT first starts counting down is called the first stage. If the host fails to reload the WDT before the 35-bit down counter reaches zero the WDT generates an internal interrupt. After the interrupt is generated, the WDT loads the value from the second Preload register into the WDT's 35-bit down-counter and starts counting down. The WDT is now in the second stage. If the host still fails to reload the WDT before the second timeout, the WDT drives the WDT_TOUT# pin low. The WDT_TOUT# pin is held low until the system is reset.

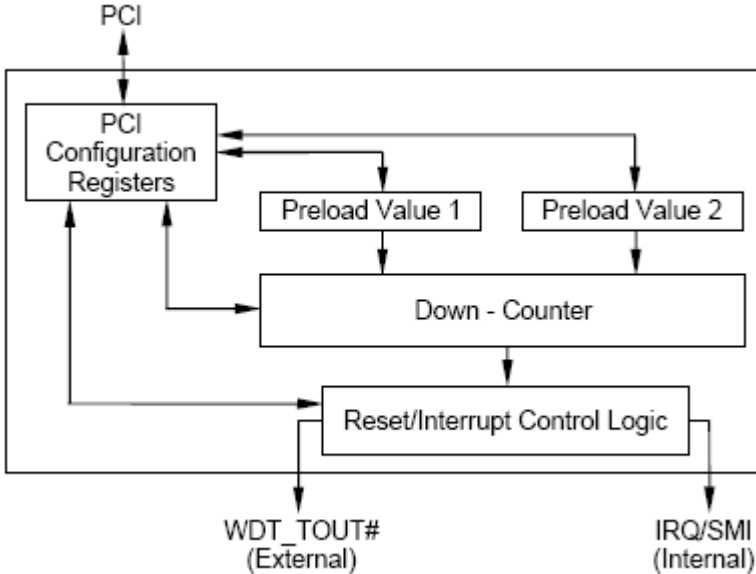

Figure 5-1: WDT Block Diagram

5.2 Configuration Registers

The Intel® 6300ESB ICH WDT, appears to BIOS as PCI Bus 0, Device 29, Function 4, and has the standard set of PCI Configuration register. The following describes the configuration registers.

Offset 10H: Base Address Register (BAR)

This register determines the memory base for WDT down-counter setting. It will be used to set Preload value 1 register, Preload value 2 register, General Interrupt Status register and Reload register.

Preload Value 1 & 2 registers

These two registers are used to hold the preload value for the WDT timer. Its value will be automatically transferred into the down-counter every time the WDT enters the first and second stage. Preload Value 1 register is located at Base + 00H and Preload Value 2 register is located at Base + 04H. Only bit [19:0] are settable.

The register unlocking sequence is necessary whenever writing to the Preload registers. Instructions for writing a value into preload value 1 & 2 registers are as follows:

1. Write 80H to offset BAR + 0CH.
2. Write 86H to offset BAR + 0CH.
3. Write desired value to preload register. (BAR + 00H or BAR + 04H)

General Interrupt Status Register

This register is at Base + 08H. Bit 0 is set when the first stage of down-counter reaches zero.

Bit 0 = 0 – No Interrupt

Bit 1 = 1 – Interrupt Active

NOTE: This bit is not set in free running mode.

Reload Register

This register is at Base + 0CH. Write 1 to bit 8 will reload the down-counter's value. Following is the procedure of how to prevent a timeout.

1. Write 80H to offset BAR + 0CH
2. Write 86H to offset BAR + 0CH
3. Write a '1' to RELOAD[8] of the reload register

Offset 60 – 61H: WDT Configuration Register

Bit 5 indicates whether or not the WDT will toggle the WDT_TOUT# pin when WDT times out. (0 = Enabled, 1 = Disabled)

Bit 2 provides two options for prescaling the main down-counter. (0 = 1ms – 10min, 1 = 1us – 1sec)

Bit [1:0] allows the user to choose the type of interrupt desired when the WDT reached the end of the first stage without being reset. (00 = IRQ, 01 = reserved, 10 = SMI, 11 = Disabled)

NOTE: The WDT does not currently support SMI. IRQ uses APIC 1, INT 10 and it is active low, level triggered.

Offset 68H: WDT Lock Register

Bit 2 is used to choose the functionality of the timer. (0 = Watchdog Timer mode, 1 = Free running mode) The free-running mode ignores the first stage and only uses Preload Value 2. In free-running mode it is not necessary to reload the timer as it is done automatically every time the down-counter reaches zero.

Bit 1 enables or disables the WDT. (0 = Disabled, 1 = Enabled)

Bit 0 will lock the values of this register until a hard reset occurs or power is cycled. (0 = unlocked, 1 = locked). The default is Unlocked.

5.3 WDT Programming Procedure

1. Make sure WDT_TOUT# signal is enabled (not GPIO[32] function).
2. Set WDT output enable, precaler and interrupt type into the WDT configuration register.
3. Get control base from the Base Address register.
4. Program Preload register's value according to unlocking sequence.
5. Set WDT timer mode into WDT Lock Register.
6. Enable WDT from WDT Lock register and program the functionality of the WDT LED.

To keep the timer from causing an interrupt or driving WDT_TOUT#, the timer must be reloaded periodically. The frequency of reloads required is dependent on the value of the preload values. To reload the down-counter, the register unlocking sequence must be performed.

To disable WDT, set bit 1 of WDT Lock Register to 0.

5.4 WDT Utilities

Users can download the [Intel® Watchdog Timer Control \(Demo\)](http://downloadfinder.intel.com/) Windows application from <http://downloadfinder.intel.com/>. Enter "6300ESB" in the search window and download the *Embedded Drivers* zip file. You will find the demo application in the *Applications* folder.

6 ePCI-X Bus Details

6.1 NuPRO-860 ePCI-X Bus

The NuPRO-860 provides both PCI-X and PCI buses. Bus-A supports 64-bit /66MHz PCI-X and bus-B supports 32-bit/33MHz PCI.

The ePCI-X Bus pin assignment is compatible with the PICMG 1.2 ePCI-X specification. In the following sections, we will describe the detailed signal definitions of the NuPRO-860 ePCI-X bus to assist in backplane selection and design.

Note: All ADLINK PCI-X backplanes are compatible with the NuPRO-860.

6.2 Global Signals

Standby Supply (+3.3Vaux)

The NuPRO-860 onboard circuit generates 3.3Vaux power from the +5Vaux or +5V. Therefore, the NuPRO-860 does not require the backplane to provide +3.3Vaux.

ATX Support

The ATX support signals include PWRGD, PSON#, PWRBT#, and +5Vaux. The NuPRO-860 design provides for ATX power control capability.

If the backplane does not provide +5Vaux, then PWRBT# and PSON# will not function under ATX power mode. In this situation, users must implement external wiring to switch on/off the power supply.

JTAG

The NuPRO-860 does NOT implement JTAG signals.

I²C Bus

The onboard SMBus is connected to the SER_SCL and SER_SDA pins.

PME#

The NuPRO-860 implements the PME# signal and connects it to 6300ESB southbridge.

6.3 PCI-X Bus Signals

Backplane Present

The a_PRSENT# and b_PRSENT# signals are connected to the Super I/O chip's GP25 and GP26 pins respectively. These signals are pulled to +3.3V via 4.7k resistors.

VIO Electrical Keying

The NuPRO-860 monitors the VIO keying signals from the backplane.

M66EN and PCIXCAP

Only Bus-A supports PCI-X at up to 66MHz. The M66EN and PCIXCAP signals of Bus-A can be used to program it to PCI mode.

Warranty Policy

Thank you for choosing ADLINK. To understand your rights and enjoy all the after-sales services we offer, please read the following carefully.

1. Before using ADLINK's products please read the user manual and follow the instructions exactly. When sending in damaged products for repair, please attach an RMA application form which can be downloaded from: <http://rma.adlinktech.com/policy/>.
2. All ADLINK products come with a two-year guarantee:
 - ▶ The warranty period starts from the product's shipment date from ADLINK's factory.
 - ▶ Peripherals and third-party products not manufactured by ADLINK will be covered by the original manufacturers' warranty.
 - ▶ For products containing storage devices (hard drives, flash cards, etc.), please back up your data before sending them for repair. ADLINK is not responsible for loss of data.
 - ▶ Please ensure the use of properly licensed software with our systems. ADLINK does not condone the use of pirated software and will not service systems using such software. ADLINK will not be held legally responsible for products shipped with unlicensed software installed by the user.
 - ▶ For general repairs, please do not include peripheral accessories. If peripherals need to be included, be certain to specify which items you sent on the RMA Request & Confirmation Form. ADLINK is not responsible for items not listed on the RMA Request & Confirmation Form.

3. Our repair service is not covered by ADLINK's two-year guarantee in the following situations:
 - ▶ Damage caused by not following instructions in the user's manual.
 - ▶ Damage caused by carelessness on the user's part during product transportation.
 - ▶ Damage caused by fire, earthquakes, floods, lightning, pollution, other acts of God, and/or incorrect usage of voltage transformers.
 - ▶ Damage caused by unsuitable storage environments (i.e. high temperatures, high humidity, or volatile chemicals).
 - ▶ Damage caused by leakage of battery fluid during or after change of batteries by customer/user.
 - ▶ Damage from improper repair by unauthorized technicians.
 - ▶ Products with altered and/or damaged serial numbers are not entitled to our service.
 - ▶ Other categories not protected under our warranty.
4. Customers are responsible for shipping costs to transport damaged products to our company or sales office.
5. To ensure the speed and quality of product repair, please download an RMA application form from our company website: <http://rma.adlinktech.com/policy>. Damaged products with attached RMA forms receive priority.

If you have any further questions, please email our FAE staff: service@adlinktech.com.