

NuPRO-850  
Full-Size ePCI-X System  
Host Board  
Intel® Pentium® 4 processor  
**User's Manual**



Recycled Paper



© Copyright 2004 ADLINK Technology Inc.

All Rights Reserved.

Manual Rev. 1.00: June 18, 2004

Part Number: 50-13045-100

The information in this document is subject to change without prior notice in order to improve reliability, design, and function and does not represent a commitment on the part of the manufacturer.

In no event will the manufacturer be liable for direct, indirect, special, incidental, or consequential damages arising out of the use or inability to use the product or documentation, even if advised of the possibility of such damages.

This document contains proprietary information protected by copyright. All rights are reserved. No part of this manual may be reproduced by any mechanical, electronic, or other means in any form without prior written permission of the manufacturer.

## **Trademarks**

NuDAQ<sup>®</sup>, NuIPC<sup>®</sup>, NuDAM<sup>®</sup>, NuPRO<sup>®</sup> are registered trademarks of ADLINK Technology Inc. Other product names mentioned herein are used for identification purposes only and may be trademarks and/or registered trademarks of their respective companies.

# Getting Service from ADLINK

Customer Satisfaction is top priority for ADLINK Technology Inc. If you need any help or service, please contact us.

<b>ADLINK TECHNOLOGY INC.</b>			
Web Site	http://www.adlinktech.com		
Sales & Service	Service@adlinktech.com		
TEL	+886-2-82265877	FAX	+886-2-82265717
Address	9F, No. 166, Jian Yi Road, Chungho City, Taipei, 235 Taiwan		

Please email or FAX your detailed information for prompt, satisfactory, and consistent service.

<b>Detailed Company Information</b>			
Company/Organization			
Contact Person			
E-mail Address			
Address			
Country			
TEL		FAX	
Web Site			
<b>Questions</b>			
Product Model			
Environment	OS: Computer Brand: M/B: CPU: Chipset: BIOS: Video Card: NIC: Other:		
Detail Description			
Suggestions for ADLINK			

# Table of Contents

<b>Chapter 1 Introduction</b> .....	<b>1</b>
1.1 Unpacking Checklist.....	2
1.2 Features.....	3
1.3 Functional Blocks and Main Board.....	4
1.4 Specifications.....	8
<b>Chapter 2 Jumpers and Connectors</b> .....	<b>11</b>
2.1 NuPRO-850 Board Outline and Illustration.....	12
2.2 NuPRO-850 Connector Pin Assignments.....	14
<b>Chapter 3 Getting Started</b> .....	<b>25</b>
3.1 CPU Installation .....	25
3.2 Memory Installation .....	26
3.3 Connecting IDE Devices to the NuPRO-850 .....	27
3.4 BIOS Configuration Overview .....	28
3.5 Operating System Installation .....	29
<b>Chapter 4 Device Driver Installation</b> .....	<b>31</b>
4.1 Intel® 875P/6300ESB Chipset .....	31
4.2 Driver Installation .....	32
<b>Chapter 5 Watchdog Timer</b> .....	<b>35</b>
5.1 Watchdog Timer.....	35
<b>Chapter 6 ePCI-X Bus Details</b> .....	<b>41</b>
6.1 NuPRO-850 ePCI-X Bus.....	41
6.2 Global Signals.....	41
6.3 PCI-X Bus Signals.....	42
<b>Warranty Policy</b> .....	<b>43</b>

# How to Use This Guide

This manual is designed to help users configure the NuPRO-850 Full-Size ePCI-X System Host Board with Dual Xeon CPU. It is divided into five chapters.

Chapter 1 **Introduction**

Gives an overview of the product features, applications, and specifications.

Chapter 2 **Connectors and Jumpers**

Outlines all the connectors and its pin definitions.

Chapter 3 **Getting Started**

Summarization of what is required to setup an operational system using the NuPRO-850. Hardware installation and BIOS overview is discussed.

Chapter 4 **Driver Installation**

Detailed instructions on how to install the software drivers successfully.

Chapter 5 **Utilities**

Explains the operation of the WDT, PXE booting, and Hardware Doctor.

# Introduction

The NuPRO-850 is a full-size ePCI-X System Host Board (SHB) based on the Intel® Pentium® 4 processor and 875P Memory Controller Hub / 6300ESB I/O Controller Hub chipset. It features AGP4X/8X VGA, Serial ATA I/F, Gigabit Ethernet, and USB v2.0 I/F. It supports two PCI/PCI-X busses via the Intel 6300ESB chipset (one PCI-X 64-bit/66MHz bus and one PCI 32-bit/33MHz bus). The NuPRO-850 is designed to run under Windows 2000/XP and Linux operating systems as well as in embedded real time applications.

The NuPRO-850 is a System Host Board with premium computing performance powered by an Intel® Pentium® 4 processor. The CPU module supports a front side bus (FSB) of 533/800MHz and a maximum CPU clock speed of 3.4GHz featuring 64-bit/66MHz PCI/PCI-X bus with up to 4GB high performance DDR host SDRAM support.

It provides input/output via RS-232, four USB 2.0 ports, Dual IDE Channels with ATA 100/66/33, Onboard Gigabit Ethernet, and video interfaces for LVDS Digital LCD Display and dual CRT displays. The NuPRO-850 is designed to meet the needs of applications which require the highest computing performance and highest reliability and is designed to run Windows 2000/XP and Linux operating systems, as well as embedded real-time applications. It is the ideal solution for telecommunications, internet, and industrial networking applications.

This chapter is designed to give the user with an overview of the NuPRO-850 SHB. This chapter covers the following topics:

- Unpacking and Checklist
- Features
- Specifications

---

## 1.1 Unpacking Checklist

Check the shipping carton for any damage. If the shipping carton and contents are damaged, notify the dealer for a replacement. Retain the shipping carton and packing materials for inspection by the dealer. Obtain authorization before returning any product to ADLINK.

Check the following items are included in the package, if there are any items missing, contact your dealer.

- The NuPRO-850 module (May be equipped with different speed or capacity CPU, RAM, and HDD).
- This User's Manual
- ADLINK CD
- Com Cable
- Dual Ports USB Cable with bracket
- 1 set of Cooler kits
- 2 x ATA-100 Cables
- 2 x Serial ATA Cables

---

**Note:** The package of the NuPRO-850 OEM version non-standard configuration may vary in function or contents according to different configuration requests

**CAUTION:** This board must be protected from static discharge and physical shock. Never remove any of the socketed parts except at a static-free workstation. Use the anti-static bag shipped with the product to handle the board. Wear a wrist strap grounded through one of the system's ESD Ground jacks while servicing system components.





---

## 1.2 Features

- PICMG 1.2 Rev 1.0 Embedded PCI-X Specification compliant.
- PCI Local Bus Specification, Rev 2.2 compliant.
- Single Intel® Pentium® 4 processor with 1MB L2 cache, 533/800MHz FSB, Hyper-Threading Technology.
- Four 184-pin DIMM sockets, support single/dual channel DDR DIMM. Up to four DIMMs of DDR 266/333/400 with ECC unbuffered. Supports a maximum of 4GB of system memory.
- Intel® 82547GI Gigabit Ethernet Controller. Supports 1000Base-TX, 100Base-TX and 10Base-T (IEEE802.3, 802.3u, and 802.3ab).
- ATI Mobility M9/M10 with AGP4X/8X compliant, 64MB memory. LVDS signal output connector supports LVDS Digital LCD Display and dual CRT displays.
- AC'97 link Interface, AC'97 2.2 compliant with optional with ADLINK DB-AC97 board.
- Supports all generic features include VGA, COM port, USB 2.0, keyboard, mouse, and hardware monitoring.
- Built-in monitoring CPU temperatures, FAN speed, system temperature, CPU voltage, and DC voltages.
- Supports Intel® Pre-boot Execution Environment (PXE).
- 2 x IDE channels, 2 x SATA ports.

## 1.3 Functional Blocks and Main Board

The following topics provide an overview of the NuPRO-850 main features as shown in the functional block diagram below and also the main board.

### Functional Block Diagram

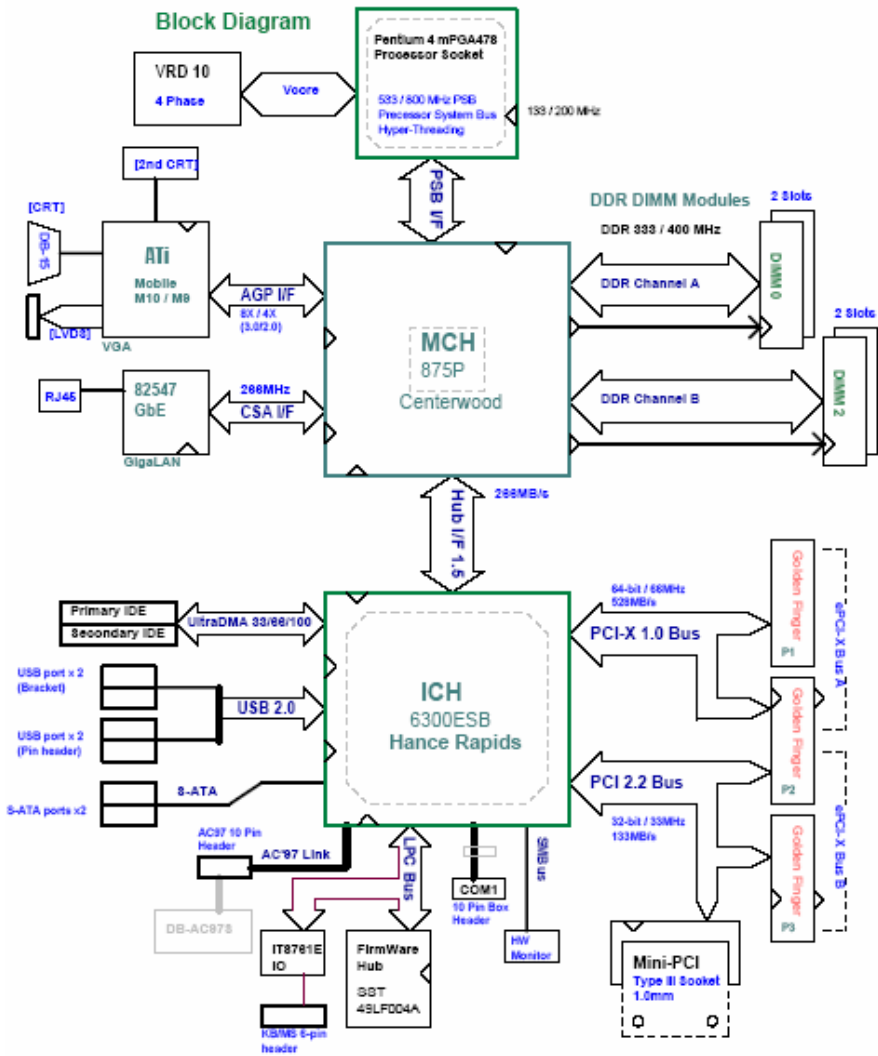

Figure 1: Functional Block Diagram

## Main Board Drawing

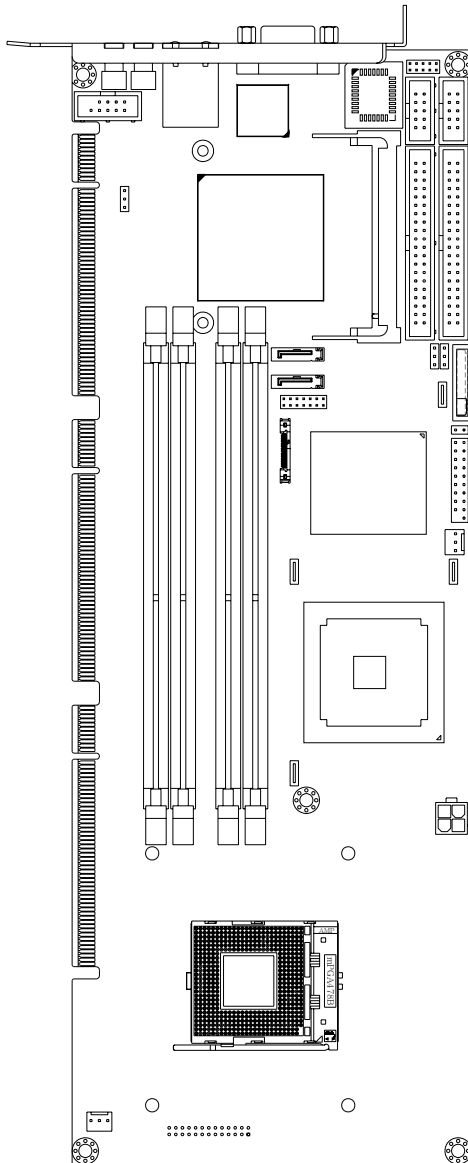

Figure 2: Main Board Drawing

### **1.3.1 Intel® Pentium® 4 Processor**

The Intel® Pentium® 4 processor is based on Intel® NetBurst® microarchitecture and built with Intel®'s 0.13-micron and 90nm manufacturing process and featuring Hyper-Threading technology, a 1MB level two-cache size. The Intel® Pentium® 4 has a maximum clock speed of 3.4GHz and front side bus frequency of 400/533/800MHz.

The Intel® NetBurst™ micro-architecture and Hyper-Threading Technology is designed specifically for multi-tasking environments and provides outstanding performance for multi-threaded applications.

### **1.3.2 Video**

The NuPRO-850 provides standard SVGA CRT analog output on a bracket I/O panel. The video function is provided via an ATI Mobility M9 (AGP4X) or M10 (AGP8X) VGA chip with 64MB video memory. NuPRO-850 also supports dual CRT output (via one onboard 14-pin header) and one LVDS interface. The NuPRO-850 has one jumper to disable the onboard video and BIOS options are used to select the resolution of the LVDS panel

### **1.3.3 Ethernet Interfaces**

The NuPRO-850 provides one 10/100/1000Mbps Ethernet interface via the Intel® 82547GI Gigabit Ethernet Controller. The 82547GI is connected to the CSA (Communicating Streaming Architecture) interface of the 875P MCH. The Ethernet interface is routed to a RJ-45 w/LED all-in-one connector on bracket. The LAN chip will be assigned one unique static MAC Address. LED drive signals for Ethernet link status and activity are routed to the same connector.

### **1.3.4 Serial I/O**

The NuPRO-850 has one RS-232 serial port with a 10-pin connector. The 16550 compatible serial port is provided by the SIU port on the Intel® 6300ESB ICH.

### **1.3.5 Universal Serial Bus (USB)**

The NuPRO-850 supports four USB 2.0 ports, with two connectors (USB0 & USB1) on bracket and the remaining (USB2 & USB3) routed to one onboard 9-pin header. USB allows for the easy addition of peripherals such as mouse, keyboard, speakers, etc.

### **1.3.6 IDE and Serial ATA Controller Controller**

The NuPRO-850 provides IDE and Serial ATA interfaces from the Intel® 6300ESB ICH. Two IDE connectors can support up to four drives Ultra DMA 100 Mode. Two serial ATA ports support up to two serial ATA devices for data transfer rates up to 150Mbps.

### **1.3.7 Software**

The NuPRO-850 is compatible with all major PC operating systems. ADLINK provides support, which may include additional drivers for ADLINK peripherals. Software device drivers for the NuPRO-850 may be found in the ADLINK CD.

### **1.3.8 AC'97 Link**

NuPRO-850 provides one AC'97 link 10-pin header, the AC'97 link is provided by the 6300ESB ICH.

### **1.3.9 Serial I/O**

NuPRO-850 provides one RS-232 serial port via one 10-pin connector. The serial port is provided by the 16550 compatible SIU port in the 6300ESB ICH.

### **1.3.10 MiniPCI slot**

NuPRO-850 provides one MiniPCI type III slot. The MiniPCI slot and ePCI-X bus B share the 6300ESB PCI bus I/F.

---

## 1.4 Specifications

### Compliant Specifications

- PICMG 1.2 Rev 1.0 Embedded PCI-X Specification compliant.
- PCI Local Bus Specification, Rev 2.2 compliant.

### Form Factor

- Standard Full-Size ePCI-X System Host Board, 338.6mm x 122mm (13.33"x4.8").

### CPU/Cache

- Intel® Pentium® 4 processor. The socket supports CPUs manufactured using Intel's 0.13-micron and 90nm manufacturing processes, FC-mPGA4 package (478-pin).
- The Intel® Pentium® 4 processor runs at a core speed of up to 3.4GHz, with a Front Side Bus (FSB) speed of 400/533/800MHz, and on-die 512KB or 1MB Advanced Transfer L2 Cache.

### Chipset

- Intel® 6300ESB I/O Controller Hub
- Intel® 82875P Memory Controller Hub (MCH)

### Host Memory

- Four DDR DIMM sockets
- 266/333/400MHz DDR DIMM modules
- Dual-channel or single-channel DDR interface
- Non-ECC and ECC, un-buffered DIMMs only
- Each socket supports up to 1GB of DDR DIMM
- 128-Mb, 256-Mb, 512Mb technologies implemented as x8, x16 DDR devices with four banks
- Up to 4GB system memory
- Registered DIMMs are not supported

DDR DIMM speed, type and size can be determined by the BIOS reading the DIMM presence detect bits on the SMBus (System Management Bus). The

DDR DIMM timing register, which provides the DIMM speed control for the entire array, must be programmed to use the timings of the slowest DIMMs installed. **Note:** DIMMs must be populated in identical pairs for dual-channel operation

### **BIOS: Award / Phoenix BIOS advanced by ADLINK**

- NuPRO-850 supports BIOS memory size up to 8Mbytes (Firmware Hub I/F).
- Flash write protection will be implemented under software control. This bit must be set to 1 before any write will be allowed to the BIOS Flash.

### **Gigabit Ethernet**

- One 10/100/1000Mbps Ethernet interfaces via the Intel® 82547GI Gigabit Ethernet Controller. The 82547GI is connected to the CSA (Communicating Streaming Architecture) interface of the 82875P MCH.
- Support 1000Base-T, 100Base-TX and 10Base-T (IEEE 802.3, 802.3u, and 802.3ab).
- IEEE802.3x compliant flow control, support auto-negotiation and link setup.
- Ethernet link status and activity LEDs on the RJ-45 connector.

### **Graphic Display**

- ATI Mobility M9 (AGP4X) or M10 (AGP8X) VGA chip with 64MB video memory.
- Standard SVGA CRT analog output on bracket I/O panel.
- Also supports 2<sup>nd</sup> CRT output (via one onboard 14-pin header) and one LVDS interface.

### **USB Interface**

- Supports four USB 2.0 ports, two connectors (USB0 & USB1) on bracket and the others (USB2 & USB3) are routed to one onboard 9-pin header

### **IDE Ports**

- Two IDE connectors support up to four drivers. Up to Ultra DMA 100 Mode.

### **Super I/O and WDT**

- Built-in HanceRapids, support 2-stage WDT, programmable timer 1 - 255 seconds or 1 - 255 minutes.

- The NuPRO-850 edge connector uses three standard 32-bit PCI connectors. These three connectors carry two busses, one PCI-X 64-bit/66MHz bus and one PCI 32-bit/33MHz bus. Both busses are provided by Intel 6300ESB ICH.

### **Hardware Monitor**

- The W83L784R provides temperature, fans, and voltage monitors. It has analog to digital converters that allow software to monitor the voltages on NuPRO-850.

### **OS Compatibility**

- MS-DOS 6.2+, Windows 2000/XP, Red Hat Linux 7.3 or higher
- Other OS support available upon request

### **Environment**

- Operating temperature: 5 to 55 °C
- Storage temperature: -40 to 70 °C
- Humidity: 5% to 95% non-condensed

### **Safety Certificate and Test**

- CE, FCC
- All plastic material used onboard are all UL-94V certified



# 2

## Jumpers and Connectors

This chapter will familiarize the user with the NuPRO-850 with the interfaces and connections available before getting started. The chapter also contains information about the board layout, connector definitions and jumper setup as well as the following information:

- NuPRO-850 board outline and illustration
- NuPRO-850 connectors pin assignments
- NuPRO-850 jumpers setting

## 2.1 NuPRO-850 Board Outline and Illustration

### 2.1.1 NuPRO-850 Top View

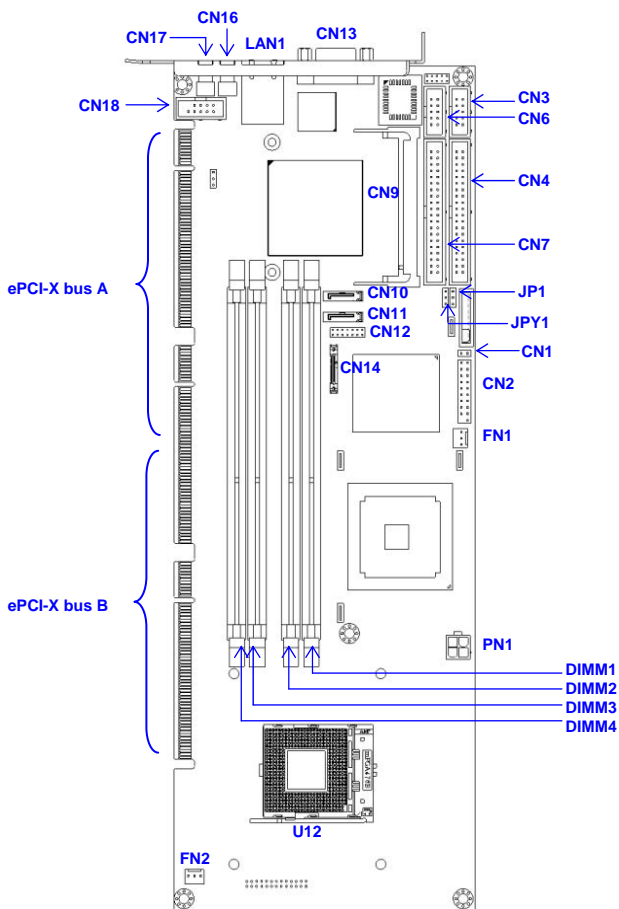

Figure 3: NuPRO-850 Top View

## 2.1.2 Front View

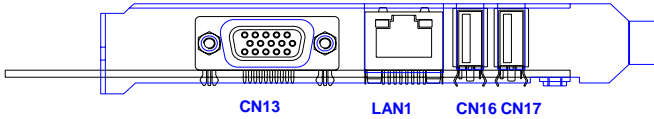

Figure 4: View of Face Plate

Position	Description
CN1	Case open pin header
CN2	Front panel pin header
CN3	COM1 connector
CN4	Secondary IDE connector
CN6	AC'97 link connector
CN7	Primary IDE connector
CN9	MiniPCI slot
CN10	SATA-1 connector
CN11	SATA-0 connector
CN12	VGA 2 <sup>nd</sup> CRT pin header
CN13	VGA CRT connector
CN14	LVDS connector
CN16	USB-0 connector
CN17	USB-1 connector
CN18	USB-2/3 pin header
LAN1	Gigabit Ethernet RJ-45 connector
FN1	VGA Fan power connector
FN2	CPU Fan power connector
DIMM1	DDR DIMM B1 socket
DIMM2	DDR DIMM B2 socket
DIMM3	DDR DIMM A1 socket
DIMM4	DDR DIMM A2 socket
U12	CPU socket
PN1	ATX 12V 4-pin connector
JP1	Clear CMOS jumper
JPY1	VGA disable jumper

Table 1: Description of Connector Locations

## 2.2 NuPRO-850 Connector Pin Assignments

A detailed description and pin-out for each connector is given in the following section.

### 2.2.1 VGA CRT connector (CN13)

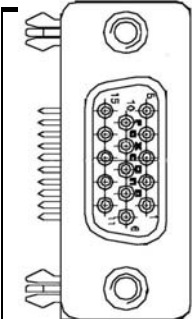

PIN	SIGNAL	FUNCTION
1	RED	Analog RED
2	GREEN	Analog GREEN
3	BLUE	Analog BLUE
4	NC	No Connect
5	GND	Ground
6	GND	Ground
7	GND	Ground
8	GND	Ground
9	5VCC	+5V
10	GND	Ground
11	NC	No connect
12	DDC_DATA	DDC Data for CRT
13	HSYNC	Horizontal sync for Monitor
14	VSYNC	Vertical sync for Monitor
15	DDC_CLK	DDC Clock for CRT

Table 2: VGA Connector Pin Definition

### 2.2.2 USB 2.0 connector (CN16, CN17)

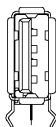

Pin #	Signal Name
1	VCC
2	USB-
3	USB+
4	Ground

Table 3: USB Connectors Pin Definition

### 2.2.3 Gigabit Ethernet connector (LAN1)

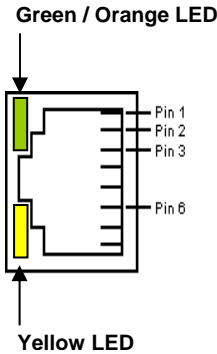

PIN	SIGNAL
1	MDI[0]+
2	MDI[0]-
3	MDI[1]+
4	MDI[1]-
5	MDI[2]+
6	MDI[2]-
7	MDI[3]+
8	MDI[3]-

Table 4: Gigabit Ethernet Connector Pin Definition

LED Color	Status	Function
Green / Orange (Speed status)	Orange	1000Mbps
	Green	100Mbps
Yellow (Link status)	ON	Link
	OFF	No link
	Blinking	Data transfer in progress

Table 5: Ethernet Color LED Status

### 2.2.4 COM1 connector (CN3)

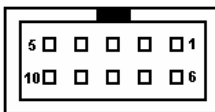

PIN	SIGNAL	FUNCTION
1	DCD	Data Carrier Detect
2	RXD	Receive Data
3	TXD	Transmit Data
4	DTR	Data Terminal Ready
5	GND	Ground
6	DSR	Data Set Ready
7	RTS	Request to Send
8	CTS	Clear to Send
9	RI	Ring Indicate
10	NC	No Connect

Table 6: Ethernet Color LED Status

## 2.2.5 AC'97 connector (CN6)

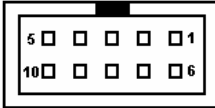

PIN	SIGNAL	FUNCTION
1	GND	Ground
2	GND	Ground
3	5VCC	+5V
4	5VCC	+5V
5	AC_SYNC	AC'97 Sync
6	AC_BITCLK	AC'97 Bit Clock
7	AC_SDIN0	AC'97 Serial Data In 0
8	AC_SDOUT	AC'97 Serial Data Out
9	AC_SDIN1	AC'97 Serial Data In 1
10	AC_RST#	AC'97 Reset

Table 7: AC'97 connector (CN6)

## 2.2.6 Case Open connector (CN1)

Signal is connected to a limit switch sensor of the chassis to detect if the case is open or closed.



PIN	SIGNAL	FUNCTION
1	CASEOPEN#	Case Open Signal
2	GND	Ground

Table 8: Case Open connector Pin Definition

### 2.2.7 VGA 2<sup>nd</sup> CRT pin header (CN12)

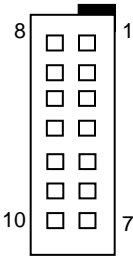

PIN	SIGNAL	FUNCTION
1	CRT2_DATA	DDC Data for CRT2
2	CRT2_CLK	DDC Clock for CRT2
3	CRT2_RED	CRT2 Analog RED
4	CRT2_GREEN	CRT2 Analog GREEN
5	CRT2_BLUE	CRT2 Analog BLUE
6	CRT2_HSYNC	CRT2 Horizontal sync for Monitor
7	CRT2_VSYNC	CRT2 Vertical sync for Monitor
8	VCC_CRT2	+5V
9	NC	No Connect
10	GND	Ground
11	GND	Ground
12	GND	Ground
13	GND	Ground
14	GND	Ground

Table 9: VGA 2<sup>nd</sup> CRT pin header (CN12)

### 2.2.8 SATA-0 / SATA-1 connectors (CN11, CN10)

CN11: SATA-0

CN10: SATA-1

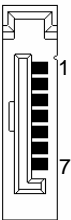

PIN	SIGNAL	FUNCTION
1	GND	Ground
2	SATA_TXP	Serial ATA Transmit Pair
3	SATA_TXN	
4	GND	Ground
5	SATA_RXN	Serial ATA Receive Pair
6	SATA_RXP	
7	GND	Ground

Table 10: SATA-0 / SATA-1 connectors (CN11, CN10)

## 2.2.9 LVDS connector (CN14)

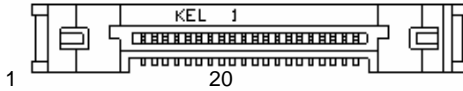

PIN	SIGNAL	FUNCTION
1	LVDS_PWR	LVDS Power
2	LVDS_PWR	LVDS Power
3	GND	Ground
4	GND	Ground
5	LVDS_L0N	LVDS lower data channel 0 (-)
6	LVDS_L0P	LVDS lower data channel 0 (+)
7	GND	Ground
8	LVDS_L1N	LVDS lower data channel 1 (-)
9	LVDS_L1P	LVDS lower data channel 1 (+)
10	GND	Ground
11	LVDS_L2N	LVDS lower data channel 2 (-)
12	LVDS_L2P	LVDS lower data channel 2 (+)
13	GND	Ground
14	LVDS_LCKN	LVDS lower clock channel (-)
15	LVDS_LCKP	LVDS lower clock channel (+)
16	GND	Ground
17	LVDS_L3N	LVDS lower data channel 3 (-)
18	LVDS_L3P	LVDS lower data channel 3 (+)
19	GND	Ground
20	GND	Ground

Table 11: LVDS connector (CN14)



### 2.2.11 ATX 12V 4-pin connector (PN1)

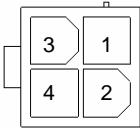

PIN	SIGNAL	FUNCTION
1	GND	Ground
2	GND	Ground
3	ATX12V	+12V
4	ATX12V	+12V

Table 12: Floppy Connector Pin Definition

### 2.2.12 Fan1 / Fan2 connector (FN1/FN2)



Pin #	Signal Name
1	GND
2	Fan power
3	Fan speed

Table 13: Floppy Connector Pin Definition

### 2.2.13 Primary/Secondary IDE Connector (CN7, CN4)

CN7: Primary IDE

CN4: Secondary IDE

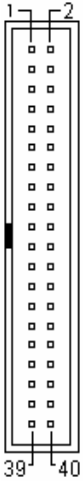

Signal Name	Pin #	Pin #	Signal Name
Reset IDE	1	2	Ground
Host data 7	3	4	Host data 8
Host data 6	5	6	Host data 9
Host data 5	7	8	Host data 10
Host data 4	9	10	Host data 11
Host data 3	11	12	Host data 12
Host data 2	13	14	Host data 13
Host data 1	15	16	Host data 14
Host data 0	17	18	Host data 15
Ground	19	20	No connect
DRQ0 / DRQ1	21	22	Ground
Host IOW	23	24	Ground
Host IOR	25	26	Ground
IOCHRDY	27	28	Host ALE
DACK0 / DACK1	29	30	Ground
IRQ14 / IRQ 15	31	32	No connect
Address 1	33	34	No connect
Address 0	35	36	Address 2
Chip select 0	37	38	Chip select 1
Activity	39	40	Ground

Table 14: IDE Connector Pin Definition

## 2.2.14 Front Panel Pin Header (CN2)

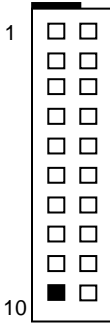

PI N	SIGNAL	FUNCTION	PIN GROUP
1	+5V	Power	Power LED
2	WDTLED#	Watch Dog LED Signal	
3	PLED	Power LED Signal	
4	NC	No Connect	Key Lock
5	GND	Ground	
6	GND	Ground	ATX Power connector
7	NC	No connect	
8	PWRON	Power-on signal	
9	+5VSB	+5V Standby Power	
10	PME# (Optional)	Power Management Event	Chassis Speaker
11	WDSPK	Speaker signal	
12	NC	No connect	
13	NC	No connect	
14	+5V	Power	RESET button
15	RESETBT	RESET Button signal	
16	GND	Ground	Hard Disk LED
17	HDDLED	Hard Disk LED signal	
18	+5V	Power	Power on button
19	PWRBT	POWER Button signal	
20	GND	Ground	

Table 15: Front Panel Pin Definition

## 2.2.15 Mini PCI Socket (CN9)

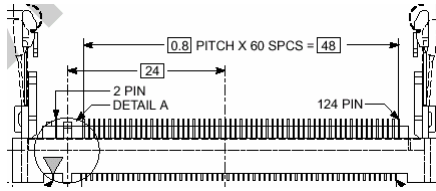

PIN	SIGNAL	PIN	SIGNAL
1	NC	2	NC
3	NC	4	NC
5	NC	6	NC
7	NC	8	NC
9	NC	10	NC
11	NC	12	NC
13	NC	14	NC
15	GND	16	EX_INTC#
17	INTB#	18	+5V
19	+3.3V	20	INTA#
21	EX_CLK	22	EX_INTD#
23	GND	24	+3.3VS
25	CLK	26	RESET#
27	GND	28	+3.3V
29	REQ#	30	GNT#
31	+3.3V	32	GND
33	AD[31]	34	PME#
35	AD[29]	36	EX_REQ#
37	GND	38	AD[30]
39	AD[27]	40	+3.3V
41	AD[25]	42	AD[28]
43	EX_IDSEL#	44	AD[26]
45	C/BE[3]	46	AD[24]
47	AD[23]	48	IDSEL#
49	GND	50	GND
51	AD[21]	52	AD[22]
53	AD[19]	54	AD[20]
55	GND	56	PAR
57	AD[17]	58	AD[18]
59	C/BE[2]	60	AD[16]
61	IRDY#	62	GND

63	+3.3V	64	FRAME#
65	CLKRUN#	66	TRDY#
67	SERR#	68	STOP#
69	GND	70	+3.3V
71	PERR#	72	DEVSEL#
73	C/BE[1]	74	GND
75	AD[14]	76	AD[15]
77	GND	78	AD[13]
79	AD[12]	80	AD[11]
81	AD[10]	82	GND
83	GND	84	AD[9]
85	AD[8]	86	C/BE[0]
87	AD[7]	88	+3.3V
89	+3.3V	90	AD[6]
91	AD[5]	92	AD[4]
93	EX_GNT#	94	AD[2]
95	AD[3]	96	AD[0]
97	+5V	98	SMBCLK
99	AD[1]	100	SMBDATA
101	GND	102	GND
103	AC_SYNC	104	GND
105	AC_SDIN	106	AC_SDOOUT
107	AC_BITCLK	108	AC_ID0#
109	AC_ID1#	110	AC_RST#
111	NC	112	NC
113	NC	114	GND
115	NC	116	NC
117	NC	118	NC
119	NC	120	NC
121	NC	122	NC
123	+5Analog	124	+3.3VSB

Table 16: Mini PCI Socket Pin Definition



# 3

## Getting Started

This chapter gives a summary of what is required to setup an operational system using the NuPRO-850, including hardware installation and an overview of the BIOS.

---

### 3.1 CPU Installation

The NuPRO-850 CPU module supports single/dual FC-mPGA2 Intel® Pentium® 4 processor with a front side bus (FSB) of 800MHz or 533MHz. Users need to install highly efficient CPU fan/cooler to guarantee the systems stability.

To install the CPU follow the steps below carefully:

1. Lift the lever on the CPU socket.
2. Insert the CPU in the socket, making sure that pin 1 of the CPU aligns with pin 1 of the socket (both corners are marked with a triangle)
3. Press the lever down until you hear it “click” into the locked position.
4. Apply the proper amount of thermal compound to the CPU die and place the heatsink and fan on top of the CPU.
5. Connect the three wires of the CPU fan to the respective CPU fan connector.

---

**Note:** Ensure that the CPU heat sink and the CPU top surface are in tight contact to avoid CPU overheating problem that would cause your system to hang or crash. The CPU heat sink and fan should be installed tightly together. Please contact ADLINK dealers for suitable heat sink and fan assemblies

---

---

## 3.2 Memory Installation

This section details the procedure for installing system memory on the NuPRO-850. Correct memory configuration is critical for proper system operation.

### 3.2.1 Memory Configuration Options

The NuPRO-850 has flexible memory configuration options. These include support for 64MB, 128MB, 256MB, 512MB, 1GB Modules. Note that the modules must all be the of the same type and density and must be installed in pairs (DIMM1 and SIMM2 or DIMM3 and DIMM4) for dual-channel mode operation.

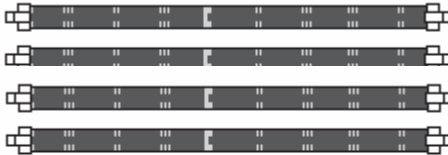

Figure 5: DIMM Sockets

### 3.2.2 Installing Memory Modules

Installing DIMM modules is simple. The modules insert in the sockets and are held in place by the socket retaining arms. The edge connectors on the modules are of different widths and there are key notches in each module. These ensure that you do not insert a module incorrectly.

Before installing any modules, a configuration should be chosen. The required number and type of DDR modules should then be prepared.



To install either types of module, follow these procedures:

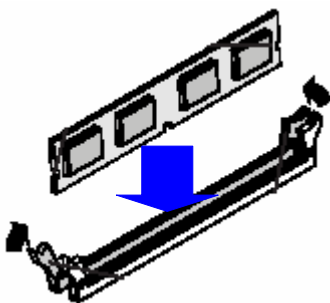

Figure 6: Inserting DIMM into Socket

1. Align the module to the socket so that the edge connectors on the module match the socket sections.
2. Hold the module perpendicular to the motherboard and press the edge connector into the socket.
3. Press the module fully into the socket so that the socket retaining arms swing up and engage the retention notches at each end of the module.
4. Following the configuration chosen, repeat for all other modules (if any).
5. Once the modules are installed, system memory installation is complete.

---

### 3.3 Connecting IDE Devices to the NuPRO-850

The NuPRO-850 supports two IDE channels, Primary and Secondary. It has two IDE device connectors onboard supporting IDE devices running in any data transfer mode up to ATA-100. Each IDE connector supports two drives, a Master and a Slave. The drives connect to the NuPRO-850 with an IDE ribbon cable.

To install an IDE drive, connect the drive to one of the drive connectors to a suitable ribbon cable. Plug the board end of the cable into one of the IDE connectors on the NuPRO-850. Make sure pin 1 of the ribbon cable connector is aligned with pin 1 of the IDE device connector.

---

## 3.4 BIOS Configuration Overview

This section gives an introduction to the Phoenix/Award Plug and Play BIOS Setup Utility. For more detailed information about the BIOS and other utilities, please refer to the BIOS Manual.

The BIOS has many separately configurable features. These features are selected by running the built-in Setup utility. System configuration settings are saved in a portion of the battery-backed RAM in the real-time clock device and are used by the BIOS to initialize the system at boot up or reset. The configuration is protected by a checksum word for system integrity.

To access the Setup utility, press the "Del" key during system RAM check at boot time. When Setup runs, an interactive configuration screen displays.

Setup parameters are divided into different categories. The available categories are listed in a menu. The parameters within the highlighted (current) category are listed in the bottom portion of the Setup screen. Context sensitive help is displayed in the right portion of the screen for each parameter.

Use the arrow keys to select a category from the menu. To display a submenu, highlight the category and then press the "Enter" key.

---

## 3.5 Operating System Installation

For more detailed information about your operating system, refer to the documentation provided by the operating system vendor.

Install peripheral devices. NuPRO devices are automatically configured by the BIOS during the boot sequence.

Most operating systems require initial installation on a hard drive from a floppy or CDROM drive. These devices should be configured, installed, and tested with the supplied drivers before attempting to load the new operating system.

Read the release notes and installation documentation provided by the operating system vendor. Be sure to read any *README* files or documents provided on the distribution disks, as these typically note documentation discrepancies or compatibility problems.

Select the appropriate boot device order in the SETUP boot menu depending on the OS installation media used. For example, if the OS includes a bootable installation floppy, select Floppy as the first boot device and reboot the system with the installation floppy installed in the floppy drive. (Note that if the installation requires a non-bootable CD-ROM, it is necessary to boot an OS with the proper CD-ROM drivers in order to access the CD-ROM drive).

Proceed with the OS installation as directed, be sure to select appropriate device types if prompted. Refer to the appropriate hardware manuals for specific device types and compatibility modes of ADLINK NuIPC products.

When installation is complete, reboot the system and set the boot device order in the SETUP boot menu appropriately.



# 4

## Device Driver Installation

To install drivers for the NuPRO-850, refer to the installation information in this chapter. Basic driver installation information for Windows XP/2000 is outlined in this section. For installation information for non-Windows Operating Systems, refer to the extensive explanations on the ADLINK CD. The drivers are located in the following directories of the CD-Rom:

Chipset driver	\\NuPRO\NuPRO-850\chipset
LAN relative driver	\\NuPRO\NuPRO-850\LAN
WDT	\\NuPRO\NuPRO-850\

---

### 4.1 Intel® 875P/6300ESB Chipset

This section describes the installation procedure for the Intel® 6300ESB chipset device driver under Windows 2000/XP.

#### 4.1.1 System Requirements

One of the following operating systems must be fully installed on the system before installing any other driver, utilities, or software:

- Windows® 2000
- Windows® XP

## 4.1.2 Hardware Configuration File Installation

This section describes how to install the hardware configuration files into a system operating Windows 2000/XP.

1. Check the System Requirements. Windows 2000/XP must be fully installed and running on the system prior to running this software.
2. Close any running applications.
3. The files are stored in an integrated application setup program. This program is designed for a Windows 2000/XP and can be executed from the **Run** command prompt.
4. Place the ADLINK CD into the CD-ROM drive. Run Setup.exe under X:\NuPRO\NuPRO-850\chipset. Where X is the CD drive letter.
5. The user will be prompted with a license agreement. Should the user not agree with the terms and conditions for using the software, the Installer will exit before extracting any files.
6. Follow the on-screen instructions and use the default settings to complete the setup, once the operating system has rebooted. This completes the installation of the Intel® Chipset Software Installation Utility.

---

## 4.2 Driver Installation

### 4.2.1 VGA Driver Installation

Windows 2000/XP will attempt to install a standard VGA driver automatically. To guarantee compatibility, manually install the most updated VGA driver, which is stored in the ADLINK CD. After installing Windows 2000/XP, update to the most updated driver by following these steps:

1. Boot Windows 2000/XP, then run the program  
**NuPRO\nuPRO-850\VGA\SETUP.EXE**
2. The VGA driver will automatically be installed onto the system.
3. Restart the system.

## 4.2.2 LAN Driver Installation

This section describes the LAN driver installation process for the **Intel® 82547** Gigabit Ethernet controller under Windows 2000/XP. The Intel® software utilities package include Diagnostics utility; Makedisk utility; and 10/100/1000Mbps Ethernet device drivers. All drivers and utilities are stored in the ADLINK CD under the directory: **X:\NuPRO\nuPRO-850\LAN**, where X: is the location of the CD-ROM drive. For driver installations of other OS, please refer to the **readme** file on the CD.

The installation procedures for Windows 2000/XP are the same. During Windows 2000/XP installation, the operating system will install a LAN driver automatically. It is recommended that the most updated LAN driver be installed, which is shipped with the ADLINK CD. This will ensure total compatibility. After installing the OS, update to the newer driver by following these steps:

1. Run the self-extracting **pro2kxpm.exe** file. The extracted files are stored to the default location **C:\IntelPRO**.
2. To install or update the Ethernet drivers for the system, click '**Install Now**'. All Ethernet devices on the computer will be updated.
3. Reboot the system for the new drivers to take effect.

---

Note: To check if there are newer updates of the drive, it is recommended that the following website <http://www.intel.com/design/software/driver/platform/> be checked out on a regular basis.

---





# Watchdog Timer

## 5.1 Watchdog Timer

The operation of the Nupro-850's watchdog timer is described in this chapter. An overview of the watchdog operation and features, as well as the programming procedure is provided to give the user an insight into the workings of the watchdog timer.

### 5.1.1 WDT Overview

The primary function of the watchdog timer is to monitor the Nupro-850's operation and to generate IRQ or to reset the system should the software fail to function as programmed. The major features of the watchdog timer are:

- Enabled and disabled through software control
- Armed and strobed through software control

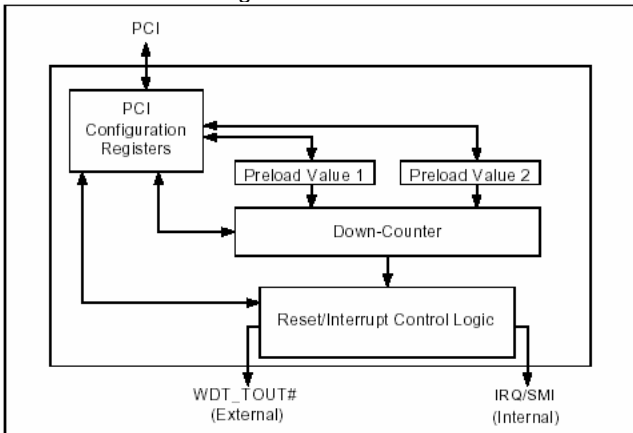

The Nupro-850's custom watchdog timer circuit is integrated in the south bridge 6300ESB.

The Intel 6300ESB ICH includes a two-stage Watchdog Timer (WDT) that provides a resolution that ranging from 1 micro second to 10 minutes. The timer uses a 35-bit Down-Counter. The counter is loaded with the value from the first Preload register. The timer is then enabled and starts counting down. The time at which the WDT first starts counting down is called the first stage. If the host fails to reload the WDT before the 35-bit down counter reaches zero the WDT generates an internal interrupt. After the interrupt is generated, the WDT loads the value from the second Preload register into the WDT's 35-bit Down-Counter and starts counting down. The WDT is now in second stage. If the host still fails to reload the WDT before the second timeout, the WDT drives the WDT\_TOUT# pin low. The WDT\_TOUT# pin is held low until the system is reset.

The WDT of 6300ESB also supports multiple modes, WDT and free-running. Free-running mode is a one stage timer and it will toggle WDT\_TOUT# after programmable time. WDT mode is a two stage timer and its operation is described as above.

### 5.1.2 Configuration Registers

The Intel® 6300ESB ICH WDT, appears to BIOS as PCI Bus 0, Device 29, Function 4, and has the standard set of PCI Configuration register. The following describes the configuration registers.

#### **Offset 10H: Base Address Register (BAR)**

This register determines the memory base for WDT down-counter setting. It will be used to set Preload value 1 register, Preload value 2 register, General Interrupt Status register and Reload register.

#### **Preload Value 1 & 2 registers**

These two registers are used to hold the preload value for the WDT timer. Its value will be automatically transferred into the down-counter every time the WDT enters the first and second stage. Preload Value 1 register is located at Base + 00H and Preload Value 2 register is located at Base + 04H. Only bit [19:0] are settable.

The register unlocking sequence is necessary whenever writing to the Preload registers. Instructions for writing a value into preload value 1&2 register are as follows:

1. Write 80H to offset BAR + 0CH.
2. Write 86H to offset BAR + 0CH.
3. Write desired value to preload register. (BAR + 00H or BAR + 04H)

## General Interrupt Status Register

This register is at Base + 08H. Bit 0 is set when the first stage of down-counter reaches zero.

Bit 0 = 0 – No Interrupt

Bit 1 = 1 – Interrupt Active

NOTE: This bit is not set in free-running mode.

## Reload Register

This register is at Base + 0CH. Write 1 to bit 8 will reload the down-counter's value. To prevent a timeout:

1. Write 80H to offset BAR + 0CH
2. Write 86H to offset BAR + 0CH
3. Write a '1' to RELOAD[8] of the reload register

## Offset 60 – 61H: WDT Configuration Register

Bit 5 indicates whether or not the WDT will toggle the WDT\_TOUT# pin when WDT times out. (0 = Enabled, 1 = Disabled)

Bit 2 provides two options for prescaling the main down-counter. (0 = 1ms – 10min, 1 = 1us – 1sec)

Bit [1:0] allows the user to choose the type of interrupt desired when the WDT reached the end of the first stage without being reset. (00 = IRQ, 01 = reserved, 10 = SMI, 11 = Disabled)

NOTE: The WDT does not support SMI now. IRQ uses APIC 1, INT 10 and it is active low, level triggered.

## Offset 68H: WDT Lock Register

Bit 2 is used to choose the functionality of the timer. (0 = Watchdog Timer mode, 1 = Free running mode) The free-running mode ignores the first stage and only uses Preload Value 2. In free-running mode it is not necessary to reload the timer as it is done automatically every time the down-counter reaches zero.

Bit 1 enables or disables the WDT. (0 = Disabled, 1 = Enabled)

Bit 0 will lock the values of this register until a hard reset occurs or power is cycled. (0 = unlocked, 1 = locked) The default is Unlocked.

## 5.1.2 GPIO Control Registers

There are two GPIOs on Nupro-850 that relate to watchdog timer. They are listed below. The GPIO control base port is 480H.

### WDT\_TOUT# pin selection

WDT\_TOUT# signal is multiplexed with GPIO32. When using WDT, this signal must be switched to WDT\_TOUT# function. It used bit 0 of GPIOBASE + 30H to set WDT\_TOUT function. (0 = WDT\_TOUT#, 1 = GPIO32)

### WDT LED Control

GPO25 of 6300ESB is designed to control WDT LED. Two features of WDT LED are supported on Nupro-850's WDT LED lights or blinks.

#### WDT LED light

Set bit 25 of GPIOBASE + 04H to 0. Bit 25 of GPIOBASE + 0CH determines the state of WDT LED. (0 = light, 1 = dark)

#### WDT LED blink

Set bit 25 of GPIOBASE + 04H to 0. Bit 25 of GPIOBASE + 18H enables WDT LED blinking function. (0 = function normally, 1 = enable blinking) The high and low times have approximately 0.5 seconds each.

## 5.1.3 The procedure of programming WDT

- Step 1: Make sure WDT\_TOUT# signal is workable. (Not GPIO32 function).
- Step 2: Set WDT output enable, presecaler and interrupt type into WDT configuration register.
- Step 3: Get control base from Base Address register.
- Step 4: Program Preload register's value according to unlocking sequence.
- Step 5: Set WDT timer mode into WDT Lock Register.
- Step 6: Enable WDT from WDT Lock register and program which functionality of WDT LED will be.

To keep the timer from causing an interrupt or driving WDT\_TOUT#, the timer must be reloaded periodically. The frequency of reloads required is dependent on the value of the preload values. To reload the down-counter, the register unlocking sequence must be performed.

To disable WDT, Set bit 1 of WDT Lock Register to 0.

### 5.1.4 Utilities

ADLINK provides a demo DOS utility, HRWDT.EXE. It is included in the driver CD. Run "*hrwdt /?*" under the following directory:

**X:\CHIPDRV\WDT\HRWDT** for a more detailed explanation.

User also can download the Intel WDT demo windows application from Intel driver download center.



# 6

## ePCI-X Bus Details

---

### 6.1 NuPRO-850 ePCI-X Bus

The NuPRO-850 provides PCI-X/PCI buses. Bus-A can run up to 64-bit PCI-X 66. Bus-B can run PCI 33MHz.

The ePCI-X Bus pin assignment is compatible with the PICMG 1.2 ePCI-X specifications. In the following sections, we will describe the detail signal definition and the design guide for the backplane designer to be compatible with the NuPRO-850 ePCI-X bus.

---

### 6.2 Global Signals

#### 6.2.1 Standby Supply (+3.3Vaux)

The NuPRO-850 onboard circuit generate 3.3Vaux power from the +5Vaux or +5V. Therefore, NuPRO-850 does not require the backplane to provide +3.3Vaux.

#### 6.2.2 ATX Support

The ATX support signals include PWRGD, PSON#, PWRBT#, +5Vaux. The NuPRO-850 design provides the ATX power control capability.

If the backplane did not provide the +5Vaux, then the PWRBT# and PSON# will not work under ATX power mode. Users have to setup the external wiring to switch on/off the power supply.

#### 6.2.3 JTAG

NuPRO-850 does NOT implement the JTAG signals.

#### 6.2.4 I<sup>2</sup>C Bus

The onboard SMBus is connected to the SER\_SCL and SER\_SDA pins.

### **6.2.5 PME#**

The NuPRO-850 implement PME# signal and connect it to 6300ESB

---

## **6.3 PCI-X Bus Signals**

### **6.3.1 Backplane Present**

The a\_PRSENT# and b\_PRSENT# signals are connected to the super I/O chip's GP25 and GP26 pins respectively. These signal are pulled to +3.3V via 4.7k resistors.

### **6.3.2 VIO Electrical Keying**

NuPRO-850 monitors the VIO keying signals from backplane.

### **6.3.3 M66EN and PCIXCAP**

The Bus-A supports up to PCI-X 66, the M66EN, and PCIXCAP of Bus-A and Bus-B can be used to program the PCI mode.



# Warranty Policy

Thank you for choosing ADLINK. To understand your rights and enjoy all the after-sales services we offer, please read the following carefully.

1. Before using ADLINK's products please read the user manual and follow the instructions exactly. When sending in damaged products for repair, please attach an RMA application form which can be downloaded from: <http://rma.adlinktech.com/policy/>.
2. All ADLINK products come with a limited two-year warranty, one year for products bought in China.
  - The warranty period starts on the day the product is shipped from ADLINK's factory.
  - Peripherals and third-party products not manufactured by ADLINK will be covered by the original manufacturers' warranty.
  - For products containing storage devices (hard drives, flash cards, etc.), please back up your data before sending them for repair. ADLINK is not responsible for any loss of data.
  - Please ensure the use of properly licensed software with our systems. ADLINK does not condone the use of pirated software and will not service systems using such software. ADLINK will not be held legally responsible for products shipped with unlicensed software installed by the user.
  - For general repairs, please do not include peripheral accessories. If peripherals need to be included, be certain to specify which items you sent on the RMA Request & Confirmation Form. ADLINK is not responsible for items not listed on the RMA Request & Confirmation Form.
3. Our repair service is not covered by ADLINK's guarantee in the following situations:
  - Damage caused by not following instructions in the User's Manual.
  - Damage caused by carelessness on the user's part during product transportation.
  - Damage caused by fire, earthquakes, floods, lightening, pollution, other acts of God, and/or incorrect usage of voltage transformers.
  - Damage caused by inappropriate storage environments such as with high temperatures, high humidity, or volatile chemicals.
  - Damage caused by leakage of battery fluid during or after change of batteries by customer/user.

- Damage from improper repair by unauthorized ADLINK technicians.
  - Products with altered and/or damaged serial numbers are not entitled to our service.
  - This warranty is not transferable or extendible.
  - Other categories not protected under our warranty.
4. Customers are responsible for all fees necessary to transport damaged products to ADLINK.

For further questions, please e-mail our FAE staff: [service@adlinktech.com](mailto:service@adlinktech.com)