

V55 System

User's Guide

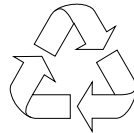

100% Recycled Paper

Copyright

Copyright © 1997 by this company. All rights reserved. No part of this publication may be reproduced, transmitted, transcribed, stored in a retrieval system, or translated into any language or computer language, in any form or by any means, electronic, mechanical, magnetic, optical, chemical, manual or otherwise, without the prior written permission of this company.

Disclaimer

This company makes no representations or warranties, either expressed or implied, with respect to the contents hereof and specifically disclaims any warranties, merchantability or fitness for any particular purpose. Any software described in this manual is sold or licensed "as is". Should the programs prove defective following their purchase, the buyer (and not this company, its distributor, or its dealer) assumes the entire cost of all necessary servicing, repair, and any incidental or consequential damages resulting from any defect in the software. Further, this company reserves the right to revise this publication and to make changes from time to time in the contents hereof without obligation to notify any person of such revision or changes.

Intel is a registered trademark of Intel Corporation.
Pentium is a trademark of Intel Corporation.

Other brand and product names are trademarks and/or registered trademarks of their respective holders.

IMPORTANT SAFETY INSTRUCTIONS

1. Read these instructions carefully. Save these instructions for future reference.
2. Follow all warnings and instructions marked on the product.
3. Unplug this product from the wall outlet before cleaning. Do not use liquid cleaners or aerosol cleaners. Use a damp cloth for cleaning.
4. Do not use this product near water.
5. Do not place this product on an unstable cart, stand, or table. The product may fall, causing serious damage to the product.
6. Slots and openings in the cabinet and the back or bottom are provided for ventilation; to ensure reliable operation of the product and to protect it from overheating, these openings must not be blocked or covered. The openings should never be blocked by placing the product on a bed, sofa, rug, or other similar surface. This product should never be placed near or over a radiator or heat register, or in a built-in installation unless proper ventilation is provided.
7. This product should be operated from the type of power indicated on the marking label. If you are not sure of the type of power available, consult your dealer or local power company.
8. This product is equipped with a 3-wire grounding-type plug, a plug having a third (grounding) pin. This plug will only fit into a grounding-type power outlet. This is a safety feature. If you are unable to insert the plug into the outlet, contact your electrician to replace your obsolete outlet. Do not defeat the purpose of the grounding-type plug.

-
9. Do not allow anything to rest on the power cord. Do not locate this product where persons will walk on the cord.
 10. If an extension cord is used with this product, make sure that the total ampere rating of the equipment plugged into the extension cord does not exceed the extension cord ampere rating. Also, make sure that the total rating of all products plugged into the wall outlet does not exceed 15 amperes.
 11. Never push objects of any kind into this product through cabinet slots as they may touch dangerous voltage points or short out parts that could result in a fire or electric shock. Never spill liquid of any kind on the product.
 12. Do not attempt to service this product yourself, as opening or removing covers may expose you to dangerous voltage points or other risks. Refer all servicing to qualified service personnel.
 13. Unplug this product from the wall outlet and refer servicing to qualified service personnel under the following conditions:
 - a. When the power cord or plug is damaged or frayed
 - b. If liquid has been spilled into the product
 - c. If the product has been exposed to rain or water
 - d. If the product does not operate normally when the operating instructions are followed. Adjust only those controls that are covered by the operating instructions since improper adjustment of other controls may result in damage and will often require extensive work by a qualified technician to restore the product to normal condition.
 - e. If the product has been dropped or the cabinet has been damaged
 - f. If the product exhibits a distinct change in performance, indicating a need for service

-
14. Replace battery with the same type as the product's battery we recommend. Use of another battery may present a risk of fire or explosion. Refer battery replacement to a qualified serviceman.
 15. Warning! Battery may explode if not handled properly. Do not recharge, disassemble or dispose of in fire. Keep away from children and dispose of used battery promptly.
 16. Use only the proper type of power supply cord set (provided in your keyboard/manual accessories box) for this unit. It should be a detachable type: UL listed/CSA certified, type SVT/SJT, rated 6A 125V minimum, VDE approved or its equivalent. Maximum length is 15 feet (4.6 meters).

FCC Class B Radio Frequency Interference Statement

Note:

This equipment has been tested and found to comply with the limits for a Class B digital device, pursuant to Part 15 of FCC Rules. These limits are designed to provide reasonable protection against harmful interference in a residential installation. This equipment generates, uses, and can radiate radio frequency energy and, if not installed and used in accordance with the instructions, may cause harmful interference to radio communications. However, there is no guarantee that interference will not occur in a particular installation. If this equipment does cause harmful interference to radio or television reception, which can be determined by turning the equipment off and on, the user is encouraged to try to correct the interference by one or more of the following measures:

1. Reorient or relocate the receiving antenna.
2. Increase the separation between the equipment and receiver.
3. Connect the equipment into an outlet on a circuit different from that to which the receiver is connected.
4. Consult the dealer or an experienced radio/television technician for help.

Notice 1:

The changes or modifications not expressly approved by the party responsible for compliance could void the user's authority to operate the equipment.

Notice 2:

Shielded interface cables, if any, must be used in order to comply with the emission limits.

About this Manual

Purpose

This user's guide aims to give you all the necessary information to enable you to operate the system properly.

Manual Structure

This user's guide consists of two chapters.

Chapter 1 System Board

This chapter describes the system board and all its major components. It contains the system board layout, jumper settings, cache and memory configurations, and information on other internal devices.

Chapter 2 BIOS Utility

This chapter gives information about the system BIOS and tells how to configure the system by changing the settings of the BIOS parameters.

Conventions

The following are the conventions used in this manual:

Text entered by user

Screen messages

ALT, ENTER, F8, etc.



Represents text input by the user.

Denotes actual messages that appear on the screen.

Represent the actual keys that you have to press on the keyboard.

NOTE

Gives bits and pieces of additional information related to the current topic.



WARNING

Alerts you to any damage that might result from doing or not doing specific actions.



CAUTION

Gives precautionary measures to avoid possible hardware or software problems.



IMPORTANT

Reminds you to do specific actions relevant to the accomplishment of procedures.



TIP

Tells how to accomplish a procedure with minimum steps



through little shortcuts.

x

Table of Contents

Chapter 1 System Board

1.1	Major Features.....	1-2
1.2	Layout.....	1-3
1.3	Jumpers and Connectors.....	1-4
1.3.1	Jumper and Connector Locations.....	1-4
1.3.2	Jumper Settings.....	1-5
1.3.3	Connector Functions.....	1-8
1.4	ESD Precautions.....	1-9
1.5	Memory Upgrade.....	1-10
1.5.1	Memory Configurations.....	1-10
1.5.2	Installing a SIMM.....	1-12
1.5.3	Removing a SIMM.....	1-13
1.5.4	Reconfiguring the System.....	1-14
1.6	IDE Hard Disk Support.....	1-14
1.7	CPU Installation.....	1-15
1.8	Second-level Cache Configuration.....	1-16
1.9	Installing ISA Cards.....	1-17
1.10	Error Messages.....	1-18
1.10.1	Software Error Messages.....	1-18
1.10.2	System Error Messages.....	1-18
1.10.3	Correcting Error Conditions.....	1-21
Chapter 2.....	BIOS Utility	
2.1	Entering Setup.....	2-2
2.2	Basic System Configuration.....	2-3

2.2.1	Date and Time.....	2-4
2.2.2	Diskette Drives.....	2-5
2.2.3	IDE Drives.....	2-6
2.2.4	Total Memory.....	2-7
2.2.5	Enhanced IDE Features.....	2-8
2.2.6	Large Memory Support Mode.....	2-9
2.2.7	Num Lock After Boot.....	2-9
2.2.8	Memory Test.....	2-9
2.2.9	Quiet Boot.....	2-9
2.2.10	Configuration Table.....	2-10
2.3	Advanced System Configuration.....	2-11
2.3.1	Internal Cache (CPU Cache).....	2-12
2.3.2	External Cache.....	2-12
2.3.3	ECC/Parity Mode Selection.....	2-12
2.3.4	Memory at 15MB-16MB.....	2-12
2.4	Power Saving Configuration.....	2-13
2.4.1	Power Management Mode.....	2-14
2.4.2	Monitored Activities.....	2-15
2.5	System Security Setup.....	2-16
2.5.1	Disk Drive Control.....	2-16
2.5.2	Onboard Communication Ports.....	2-18
2.5.3	Onboard PS/2 Mouse (IRQ 12).....	2-20
2.5.4	Setup Password.....	2-21
2.5.5	Power On Password.....	2-23
2.6	PnP/PCI System Configuration.....	2-24
2.6.1	PCI IRQ Setting.....	2-24
2.6.2	PCI IRQ Sharing.....	2-25

2.6.3	VGA Palette Snoop.....	2-25
2.6.4	Plug & Play OS.....	2-26
2.6.5	Reset Resources Assignment.....	2-26
2.7	Load Setup Default Settings.....	2-27
2.8	Leaving Setup.....	2-27

List of Figures

1-1	System Board Layout.....	1-3
1-2	System Board Jumper and Connector Locations.....	1-4
1-3	S1 Multifunction Switch.....	1-6
1-4	20-Pin Multifunction Connector (CN16).....	1-9
1-5	Installing a SIMM.....	1-12
1-6	Removing a SIMM.....	1-13
1-7	Installing a Pentium CPU.....	1-15
1-8	Installing a Cache Module.....	1-16

List of Tables

1-1	Jumper Settings.....	1-5
1-2	S1 Settings for CPU Selection.....	1-7
1-3	Connector Functions.....	1-8
1-4	Memory Configurations (64-bit).....	1-10
1-5	Memory Configurations (32-bit).....	1-11
1-6	IDE Hard Disk Configuration.....	1-14
1-7	System Error Messages.....	1-19
2-1	Drive Control Settings.....	2-17
2-2	Serial Port 1 Settings.....	2-18
2-3	Serial Port 2 Settings.....	2-18
2-4	Parallel Port Settings.....	2-19
2-5	Parallel Port Operation Mode Settings.....	2-20

Chapter 1

System Board

The V55 is a high-performance system board with a 64-bit architecture. It supports the P54C, P55C, Cyrix M1 (P120+, P150+, P166+ - single and dual voltage), AMD K5 (PR166), and AMD K6 (PR200) CPUs. The system board utilizes the Peripheral Component Interconnect (PCI) local bus architecture that maximizes the system performance by enabling high-speed peripherals to match the speed of the microprocessor with its 120 MB or 132 MB per second transfer rate in burst mode.

Two DRAM banks composed of four 72-pin sockets come with the board to support single- and double-density SIMMs for a maximum system memory of 128 MB. The SIMM sockets accommodate both the standard page mode and extended data output (EDO) SIMMs. An exclusive slot comes with the board to allow a cache upgrade of up to 512 KB using a pipeline burst cache module.

The two onboard PCI-enhanced IDE interfaces with a zero-wait state and 16.6 MB per second transfer rate support up to four IDE devices. Onboard I/O interfaces comprise of two UART 16550 serial ports, a parallel port with ECP/EPP feature, and PS/2 keyboard and mouse ports. An AT keyboard is an option.

1.1 Major Features

The system board has the following major features:

- A zero-insertion force (ZIF) socket for P54C, P55C, Cyrix M1 (P120+, P150+, P166+ - single and dual voltage), AMD K5 (PR166), and AMD K6 (PR200) CPUs
- Two DRAM banks composed of four 72-pin SIMM sockets that support 4/8/16/32-MB 60/70 ns SIMMs (use of 60 ns DRAMs recommended; 60 ns DRAMs meet the chipset default DRAM timing)
- Three ISA and four PCI bus expansion slots
- 256/512-KB onboard pipeline-burst second-level cache. If the board comes with 256-KB cache, you may upgrade it to 512 KB by installing a UMC UM61 3232AF-7 256K cache module.
- 128-KB Flash ROM for system BIOS
- Two PCI-enhanced IDE interfaces that support up to four IDE devices
- System clock/calendar with 256-byte CMOS RAM
- PS/2 keyboard and mouse ports (optional AT keyboard port)

1.2 Layout

Figure 1-1 shows the locations of the system board major components.

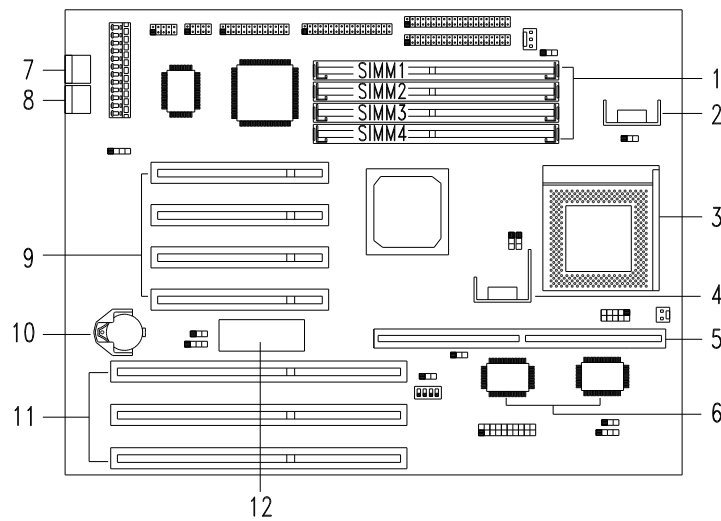

- | | | | |
|---|-----------------------------------|----|---------------------|
| 1 | SIMM sockets | 7 | PS/2 keyboard port |
| 2 | CPU voltage regulator | 8 | PS/2 mouse port |
| 3 | CPU socket | 9 | PCI expansion slots |
| 4 | CPU voltage regulator | 10 | Battery |
| 5 | Cache module socket | 11 | ISA expansion slots |
| 6 | Pipeline burst second-level cache | 12 | BIOS |

Figure 1-1 System Board Layout

1.3 Jumpers and Connectors

1.3.1 Jumper and Connector Locations

Figure 1-2 shows the jumper and connector locations on the system board.

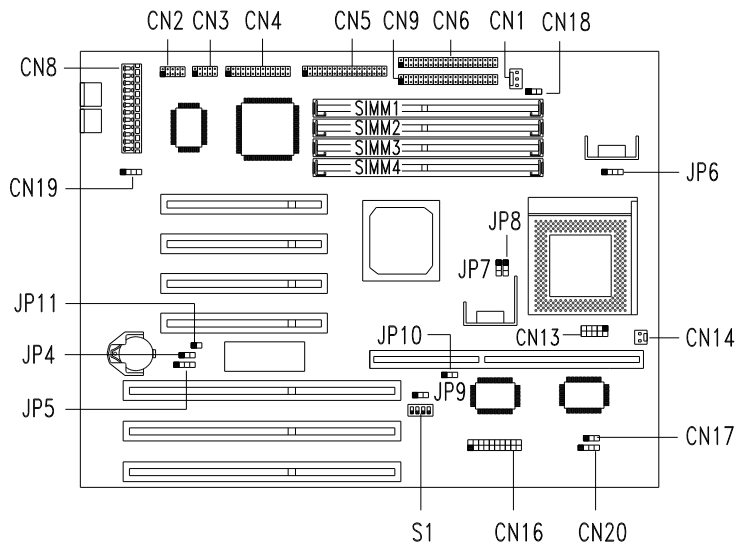

Figure 1-2 System Board Jumper and Connector Locations



The blackened pin of a jumper or connector represents pin 1.

1.3.2 Jumper Settings

Table 1-1 lists the system board jumpers with their corresponding settings and functions.

Table 1-1 Jumper Settings

Jumper	Setting	Function
ROM Type JP4	1-2 2-3*	EPROM Flash ROM
ROM Brand JP5	1-2 2-3* 3-4	NC 29EE010 28F001
CPU Core Voltage JP6	1-2 2-3*	3.2V 2.8V
CPU I/O Voltage JP7	1-2 2-3*	3.5V 3.3V
L2 Cache Size JP8, JP9	1-2 2-3*	512 KB 256 KB
L2 Cache Mode JP10	1-2 2-3*	Reserved Normal operation
Clearing CMOS JP11	Open Shorted	Normal operation Clear CMOS

* Default setting

Clearing CMOS

In case you forget your password, short JP11 to clear the CMOS. There is no physical jumper on the location of JP11. Instead, you will find two solder pads representing JP11.

Follow these steps to short JP11:

1. Remove the system battery from its socket.
2. Use a wire to short the two solder pads for about 10 seconds.
3. Re-insert the system battery into the socket.

Selecting a CPU

A multifunction switch marked S1 comes onboard to allow selection of the CPU clock frequency and core/clock ratio depending on the CPU type.

Figure 1-3 shows the S1 multifunction switch.

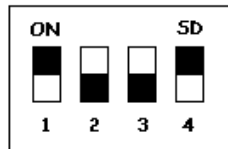

Figure 1-3 S1 Multifunction Switch

Table 1-2 lists the settings and functions of the S1 multifunction switch.

Table 1-2 SI Settings for CPU Selection

CPU Freq. (MHz)	Host Bus Freq. (MHz)	Switch Settings				Clock Ratio
		SW1	SW2	SW3	SW4	
Intel P54C/P55C, AMD K5 /K6						
233	66	Off	Off	On	Off	7/2
200	66	On	Off	On	Off	3
180	60	On	Off	Off	On	3
166	66	On	On	On	Off	5/2
150	60	On	On	Off	On	5/2
133	66	Off	On	On	Off	2
120	60	Off	On	Off	On	2
100	66	Off	Off	On	Off	3/2
90	60	Off	Off	Off	On	3/2
75	50	Off	Off	On	On	3/2
Reserved	--	--	--	--	--	--
Cyrix M1/IBM 6x86						
P166+	66	Off	On	On	Off	2
P150+	60	Off	On	Off	On	2
P120+	50	Off	On	On	On	2



Note that the 233 MHz CPU frequency applies to the Intel Pentium CPU only.

1.3.3 Connector Functions

Table 1-3 lists the different connectors on the system board and their respective functions.

Table 1-3 Connector Functions

Connector	Function
CN1	Standby power connector
CN2	Serial port 2 connector
CN3	Serial port 1 connector
CN4	Parallel port connector
CN5	Diskette drive connector
CN6	IDE 2 connector
CN8	Power connector
CN9	IDE 1 connector
CN10	PS/2 keyboard port
CN11	PS/2 mouse port
CN13	CPU power shorting block
CN14	CPU fan connector
CN16	Multifunction connector
CN17	External suspend switch
CN18	Software shutdown switch
CN19	IrDA connector (optional)
CN20	IDE LED connector

The multifunction connector CN16 accommodates the front panel connectors for speaker, LEDs, keylock, and reset. Figure 1-4 shows the CN16 pin assignments for each of the front panel connectors.

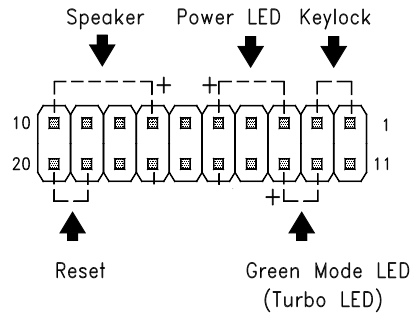

Figure 1-4 20-Pin Multifunction Connector (CN16)

1.4 ESD Precautions

Always observe the following electrostatic discharge (ESD) precautions before installing a system component:

1. Do not remove a component from its antistatic packaging until you are ready to install it.
2. Wear a wrist grounding strap before handling electronic components. Wrist grounding straps are available at most electronic component stores.



Do not attempt the procedures described in the following sections unless you are a qualified technician.

1.5 Memory Upgrade

The system board comes with four 72-pin SIMM sockets that support 4-MB and 16-MB single-density SIMMs and 8-MB and 32-MB double-density SIMMs. Tables 1-4 and 1-5 list the possible memory configurations.

1.5.1 Memory Configurations

Table 1-4 Memory Configurations (64-bit)

Bank 0		Bank 1		Total Memory
SIMM-1	SIMM-2	SIMM-3	SIMM-4	
4 MB	4 MB			8 MB
		4 MB	4 MB	8 MB
8 MB	8 MB			16 MB
		8 MB	8 MB	16 MB
4 MB	4 MB	4 MB	4 MB	16 MB
4 MB	4 MB	8 MB	8 MB	24 MB
8 MB	8 MB	4 MB	4 MB	24 MB
8 MB	8 MB	8 MB	8 MB	32 MB
16 MB	16 MB			32 MB
		16 MB	16 MB	32 MB
4 MB	4 MB	16 MB	16 MB	40 MB
16 MB	16 MB	4 MB	4 MB	40 MB
8 MB	8 MB	16 MB	16 MB	48 MB
16 MB	16 MB	8 MB	8 MB	48 MB
16 MB	16 MB	16 MB	16 MB	64 MB
32 MB	32 MB			64 MB
		32 MB	32 MB	64 MB
4 MB	4 MB	32 MB	32 MB	72 MB
32 MB	32 MB	4 MB	4 MB	72 MB
8 MB	8 MB	32 MB	32 MB	80 MB
32 MB	32 MB	8 MB	8 MB	80 MB
16 MB	16 MB	32 MB	32 MB	96 MB
32 MB	32 MB	16 MB	16 MB	96 MB
32 MB	32 MB	32 MB	32 MB	128 MB

The system also supports 32-bit memory configurations. This feature allows installation of only one SIMM in a bank or in one configuration. It also allows random installation of SIMMs in any of the sockets. Table 1-5 lists the 32-bit memory configurations.

Table 1-5 Memory Configurations (32-bit)

Bank 0		Bank 1		Total Memory
SIMM-1	SIMM-2	SIMM-3	SIMM-4	
4 MB*				4 MB
4 MB*	4 MB*	4 MB*		12 MB
4 MB	4 MB	8 MB		16 MB
4 MB	4 MB	16 MB		24 MB
4 MB	4 MB	32 MB		40 MB
8 MB				8 MB
8 MB	8 MB	4 MB		20 MB
8 MB	8 MB	8 MB		24 MB
8 MB	8 MB	16 MB		32 MB
8 MB	8 MB	32 MB		48 MB
16 MB				16 MB
16 MB	16 MB	4 MB		36 MB
16 MB	16 MB	8 MB		40 MB
16 MB	16 MB	16 MB		48 MB
16 MB	16 MB	32 MB		64 MB
32 MB				32 MB
32 MB	32 MB	4 MB		68 MB
32 MB	32 MB	8 MB		72 MB
32 MB	32 MB	16 MB		80 MB
32 MB	32 MB	32 MB		96 MB



The system does not support ECC and parity check features while in 32-bit access.

* May also be installed in the other sockets. The same applies to the other configurations.

1.5.2 Installing a SIMM

Follow these steps to install a SIMM:

1. Carefully slip a SIMM at a 45° angle into a socket making sure that the curved edge indicating the pin 1 of the SIMM matches pin 1 of the socket.



A SIMM fits only in one direction. If you slip in a SIMM but would not completely fit, you may have inserted it the wrong way. Reverse the orientation of the SIMM.

2. Gently push the SIMM to a vertical position until the pegs of the socket slip into the holes on the SIMM, and the holding clips lock the SIMM into position. The SIMM should be at a 90° angle when installed.

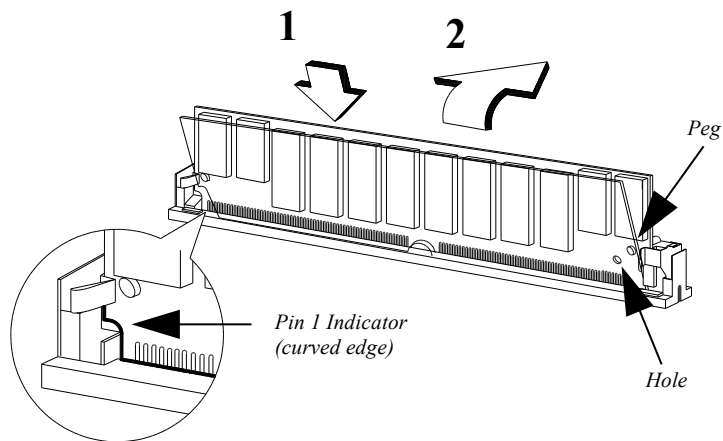

Figure 1-5 Installing a SIMM

1.5.3 Removing a SIMM

Follow these steps to remove a SIMM:

1. Press the holding clips on both sides of the SIMM outward to release it.
2. Move the SIMM to a 45° angle.
3. Pull the SIMM out of the socket.

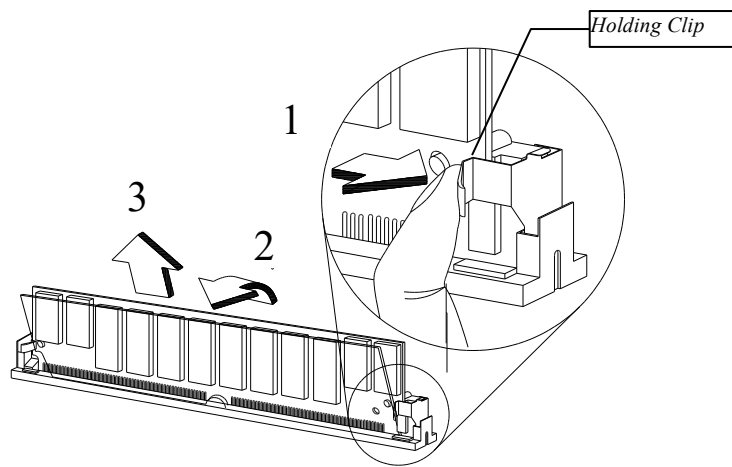

Figure 1-6 Removing a SIMM



Always remove SIMMs from the socket labeled SIMM4, then SIMM3, and so on.

1.5.4 Reconfiguring the System

You must enter Setup after installing or removing SIMMs to reconfigure the system.

Follow these steps to reconfigure the system:

1. Turn the system on. A memory error message appears, indicating that the total memory does not match the value stored in CMOS.
2. Press **CTRL** + **ALT** + **ESC** to enter Setup. A warning message appears indicating an incorrect memory configuration.
3. Press **ESC** twice to exit and reboot the system.
The system boots with the new memory configuration.

1.6 IDE Hard Disk Support

The system board supports four IDE hard disks, or any other IDE devices, through the two onboard PCI IDE interfaces. See Figure 1-1 for the location. Follow the instructions in the housing installation manual on how to install a hard disk in the system. Connect the cables according to the IDE hard disk configuration in Table 1-6.

Table 1-6 IDE Hard Disk Configuration

IDE Connector	Master	Slave
Channel 1	Hard disk 0	Hard disk 1
Channel 2	Hard disk 2	Hard disk 3

1.7 CPU Installation

The system board comes with a zero-insertion force (ZIF) CPU socket for easy installation.

Follow these steps to install a Pentium CPU:

1. Set JP6 to the correct CPU core voltage, JP7 to the CPU I/O voltage, and S1 for the CPU frequency. Refer to Tables 1-1 and 1-2 for the appropriate settings and to your CPU documentation for more information.
2. If you install a dual-voltage CPU, remove the shorting block on CN13. See your CPU documentation for the specifications.
3. Lift up the CPU socket lever.
4. Insert the CPU into the socket. Make sure that the notched corner of the CPU matches the pin 1 indicator on the socket.
5. Push down the socket lever.

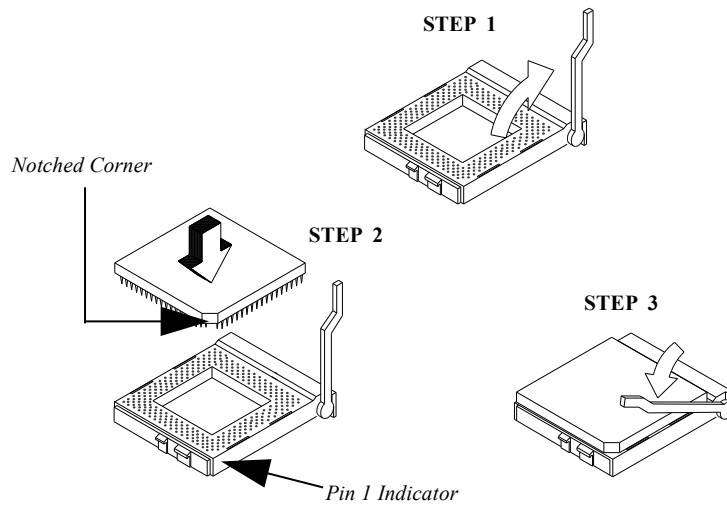

Figure 1-7 Installing a Pentium CPU

1.8 Second-level Cache Configuration

The system board has an onboard 256-KB or 512-KB synchronous second-level cache. The 160-pin cache module slot that comes with the board supports a pipeline burst SRAM module. If the board comes with a 256-KB cache, you can upgrade it to 512 KB by installing a UMC UM61 3232AF-7 256K cache module.

Follow these steps to install a cache module:

1. Position the cache module on top of the slot such that its component side faces the CPU.
2. Insert the cache module carefully until the golden finger of the module fit into place.

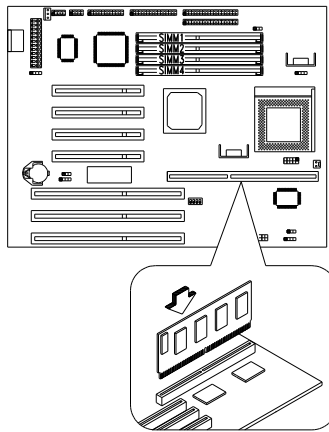

Figure 1-8 Installing a Cache Module

3. Set jumpers JP8 and JP9 to the correct second-level cache size.
Do not forget this step. The system will not work properly if JP8 and JP9 are not set properly.



1.9 Installing ISA Cards

Both PnP and non-PnP ISA cards require specific IRQs. When installing ISA cards, make sure that the IRQs required by these cards are not previously assigned to PCI devices to avoid resource conflicts.

Follow these steps when installing ISA cards:

1. Remove all PnP cards installed in the system, if any.
2. Enter BIOS utility and set the Reset Resource Assignment parameter to **Yes** to clear the resource data assigned to the PnP devices. Refer to section 2.6.5.
3. Install non-PnP ISA cards.
4. Turn on the system.
5. Use Windows 95 or ICU to manually assign the appropriate IRQs to the cards. This ensures that BIOS will not use the resources assigned to the non-PnP ISA cards.



BIOS detects and configures only PnP cards.

6. Turn off the system.
7. Install PnP ISA and PCI cards.
8. Turn on the system. This time PnP BIOS automatically configures the PnP ISA and PCI cards with the remaining free IRQs.

1.10 Error Messages

Do not continue using the computer if you receive an error message of any type. Note the message and take corrective action. This section explains the different types of error messages and corresponding corrective measures.

There are two general types of error messages:

- Software
- System

1.10.1 Software Error Messages

Software error messages are returned by your operating system or application. These messages typically occur after you boot the operating system or when you run your applications. If you receive this type of message, consult your application or operating system manual for help.

1.10.2 System Error Messages

A system error message indicates a problem with the computer itself. A message of this type normally appears during the power-on self-test, before the operating system prompt appears.

Table 1-7 lists the system error messages.

Table 1-7 System Error Messages

Message	Action
CMOS Battery Error	Replace the battery chip or contact your dealer.
CMOS Checksum Error	Load the BIOS default settings or contact your dealer.
Diskette Drive Controller Error or Not Installed	Check the diskette drive cables if properly connected.
Diskette Drive Error	Diskette drive may be defective. If it is, replace the drive.
Diskette Drive A Type Mismatch	Run Setup and select the proper drive type.
Diskette Drive B Type Mismatch	Run Setup and select the proper drive type.
Equipment Configuration Error	Modify the memory configuration to agree with one of the options in Tables 1-4 and 1-5.
Hard Disk Controller Error	Run Setup.
Hard Disk 0 Error	Check all cable connections. Replace hard disk.
Hard Disk 1 Error	Check all cable connections. Replace hard disk.
Keyboard Error or No Keyboard Connected	Check and connect the keyboard to the system unit.
Keyboard Interface Error	Replace the keyboard or contact your dealer.

Table 1-7 System Error Messages (continued)

Message	Action
Memory Error at: MMMM:SSSS:OOO (W:XXXX, R:YYYY) where: M: MB, S: Segment, O: Offset, X/Y: write/read pattern	Check SIMMs on the system board. Contact your dealer.
CPU Clock Mismatch	Run Setup. Check if the CPU clock is correct. If correct, exit Setup and reboot the system. If the error message reappears, ask for technical assistance.
Onboard Serial Port 1 Conflict	Run Setup and disable the port.
Onboard Serial Port 2 Conflict	Run Setup and disable the port.
Onboard Parallel Port Conflict	Run Setup and disable the port.
Pointing Device Error	Check and connect pointing device.
Pointing Device Interface Error	Replace the pointing device or contact your dealer.
Press F1 key to continue or Ctrl+Alt+Esc for Setup	Press F1 or CTRL + ALT + ESC to enter Setup.
Real Time Clock Error	Contact your dealer.

1.10.3 Correcting Error Conditions

As a general rule, if an error message says "Press F1 to continue," it is caused by a configuration problem, which can be easily corrected. An equipment malfunction is more likely to cause a fatal error, i.e., an error that causes complete system failure.

Here are some corrective measures for error conditions:

1. Run Setup. You must know the correct configuration values for your system before you enter Setup, which is why you should write them down when the system is correctly configured. An incorrect configuration is a major cause of power-on error messages, especially for a new system.
2. Remove the system unit cover. Check that the jumpers on the system board and any expansion boards are set correctly.
3. If you cannot access a new disk, it may be because your disk is not properly formatted. Format the disk first using the FDISK and FORMAT commands.
4. Check that all connectors and boards are securely plugged in.

If you go through the corrective steps above and still receive an error message, the cause may be an equipment malfunction.

If you are sure that your configuration values are correct and your battery is in good condition, the problem may lie in a damaged or defective chip.

In both cases, contact an authorized service center for assistance.

Chapter 2

BIOS Utility

Most systems are already configured by the manufacturer or the dealer. There is no need to run Setup when starting the computer unless you get a Run Setup message.

The Setup program loads configuration values into the battery-backed nonvolatile memory called CMOS RAM. This memory area is not part of the system RAM.



If you repeatedly receive Run Setup messages, the battery may be bad. In this case, the system cannot retain configuration values in CMOS. Ask a qualified technician for assistance.

Before running Setup, make sure that you have saved all open files. The system reboots immediately after you exit Setup.

2.1 Entering Setup

To enter Setup, press the key combination **CTRL**+**ALT**+**ESC** .



*You must press **CTRL**+**ALT**+**ESC** while the system is booting. This key combination does not work during any other time.*

The BIOS Utility main menu then appears:

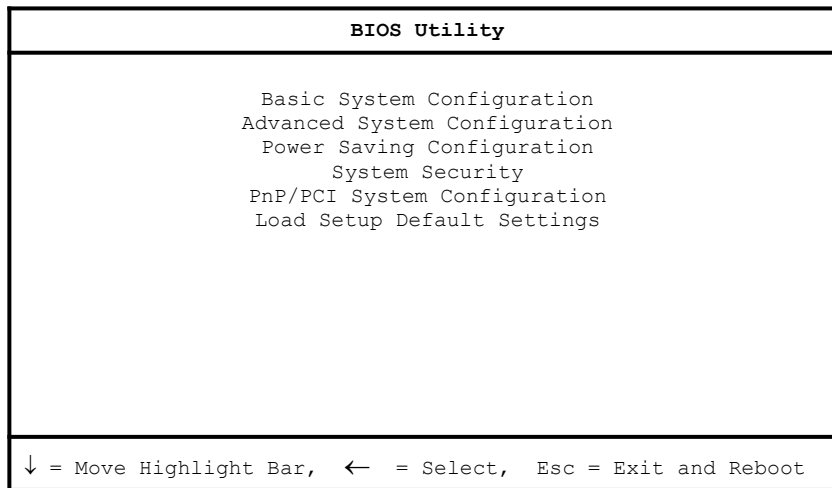

The parameters on the screens show default values. These values may not be the same as those in your system.

The grayed items (denoted with asterisks) on the screens have fixed settings and are not user-configurable.

2.2 Basic System Configuration

Select Basic System Configuration to input configuration values such as date, time, and disk types.

The following screen shows the Basic System Configuration menu.

Basic System Configuration		Page 1/2		
Date	[MM/DD/YY]			
Time	[HH:MM:SS]			
Diskette Drive A	[xx-MB	xx-inch]		
Diskette Drive B	[xx-MB	xx-inch]		
		Cylinder	Head	Sector
IDE Drive 0 (xxx MB).....	[Auto]	xx	xx	xx
IDE Drive 1 (xxx MB).....	[Auto]	xx	xx	xx
IDE Drive 2	[Auto]			
IDE Drive 3	[Auto]			
Total Memory	[xxxx] KB			
↓ = Move Highlight Bar, → ← = Change Setting PgDn/PgUp = Move Screen, F1 = Help, Esc = Exit				

The command line at the bottom of the menu tells you how to highlight items, change settings, and move from one screen to another.

Press **↑** or **↓** on the cursor-edit keypad to highlight the desired parameter.

Press **→** or **←** to select the desired option for a parameter.

Press **PGDN** to move to the next page or **PGUP** to return to the previous page.

Press **ESC** to exit the configuration menu.

The following screen shows page 2 of the Basic System Configuration menu.

```
Basic System Configuration                               Page 2/2

Enhanced IDE Features
  Hard Disk Block Mode .....[Enabled ]
  Advanced PIO Mode .....[Enabled ]
  Hard Disk Size > 504MB .....[Enabled ]
  Hard Disk 32-Bit Access .....[Enabled ]

Large Memory Support Mode.....[Normal  ]
Num Lock After Boot .....[Enabled ]
Memory Test .....[Disabled]
Quiet Boot .....[Enabled ]
Configuration Table .....[Disabled]



↓ = Move Highlight Bar,   → ← = Change Setting
PgDn/PgUp = Move Screen,  F1 = Help,   Esc = Exit
```

The following sections explain the different parameters and their settings.

2.2.1 Date and Time

The real-time clock keeps the system date and time. After setting the date and time, you need not enter them every time you turn on the system. As long as the internal battery remains good (approximately seven years) and connected, the clock continues to keep the date and time accurately even when the power is off.

Date

Highlight the items on the date parameter and press  or  to set the date following the month-day-year format.

Valid values for month, day, and year are:

- Month 1 to 12
- Day 1 to 31
- Year 00 to 99

Time

Highlight the items on the time parameter and press or to set the time following the hour-minute-second format.

Valid values for hour, minute, and second are:

- Hour 00 to 23
- Minute 00 to 59
- Second 00 to 59

2.2.2 Diskette Drives

To enter the configuration value for the first diskette drive (drive A), highlight the Diskette Drive A parameter. Press or key to view the options and select the appropriate value.

Possible settings for the Diskette Drive parameters:

- [None]
- [360 KB, 5.25-inch]
- [1.2 MB, 5.25-inch]
- [720 KB, 3.5-inch]
- [1.44 MB, 3.5-inch]
- [2.88 MB, 3.5-inch]

Follow the same procedure for Diskette Drive B. Choose None if you do not have a second diskette drive.

2.2.3 IDE Drives

Move the highlight bar to the IDE Drive 0 parameter to configure the first IDE drive (drive C). Press **→** or **←** to display the IDE drive types with their respective values. Select the type that corresponds to your IDE hard disk drive. Follow the same procedure for the other IDE drives, if any. Choose **None** if you do not have other drives.

Selecting the “Auto” Option

If you do not know the exact type of your IDE hard disk drive, select the option **Auto**. During the power-on self-test (POST), when the system performs self-testing and self-initialization before loading the operating system and applications, the BIOS utility automatically determines your IDE drive type. You can see the drive type and its values when you enter the BIOS Utility.

```

                                     Cylinder Head Sector
IDE Drive 0 (xx MB)....[Auto]      xx      xx      xx
```

If desired, you can save the values under the option **User**.

```

                                     Cylinder Head Sector
IDE Drive 0 (xx MB)....[User]      xx      xx      xx
```

The next time you boot the system, the BIOS utility does not have to auto-configure your IDE drive as it detects the saved disk information during POST.



Copy the IDE disk drive values and keep them in a safe place in case you have to reconfigure the disk in the future.

Follow the same procedure to auto-configure other IDE drives.

Selecting the “User” Option

There are cases when you cannot use the option *Auto*, instead you have to select *User*. Choose the *User* option when you have installed an IDE hard disk that was previously formatted but does not use the disk native parameters or structure, that is, the disk type may be in the IDE hard disk types list but the number of cylinders, heads, and sectors differ.

Follow these steps to configure an IDE hard disk with the *User* option:

1. Highlight an IDE drive parameter.
2. Select the option *User* and press **ENTER**.
3. Type in the number of cylinders, heads, and sectors of the drive under the appropriate columns.



Be sure to have the correct IDE hard disk drive information beforehand.

4. Choose **YES** when asked if you want to save CMOS data.

2.2.4 Total Memory

The system automatically detects the total amount of onboard memory during POST and sets this parameter accordingly. If you install additional memory, the system automatically adjusts the Total Memory parameter to display the new memory size.

2.2.5 Enhanced IDE Features

Hard Disk Block Mode

This function enhances disk performance depending on the hard disk in use. If you set this parameter to *Enabled*, it allows data transfer in block (multiple sectors). If your system does not boot after enabling this parameter, change the setting to *Disabled*. This parameter is normally set to *Enabled*.

Advanced PIO Mode

Enabling this parameter allows for faster data recovery and read/write timing that reduces hard disk activity time. This results to better hard disk performance.

To utilize this feature, your hard disk must support the advanced PIO mode. If not, set this parameter to *Disabled*. Refer to your hard disk documentation for information about the advanced PIO mode.

Hard Disk Size > 504 MB

This enhanced IDE feature works only under DOS and Windows 3.x environments. If enabled, it allows you to use a hard disk with a capacity of more than 504 MB. This is made possible through the Logical Block Address (LBA) mode translation. Other operating systems require this parameter to be set to *Disabled*.

To prevent data loss, keep this parameter set to *Enabled* if you are using a hard disk with more than 504 MB capacity that was previously configured through LBA mode. When you use a hard disk configured through the cylinder-head-sector (CHS) mode, set this parameter to *Disabled*.

Hard Disk 32-Bit Access

Enabling this parameter improves system performance by allowing the use of the 32-bit hard disk access. This enhanced IDE feature works only under DOS, Windows 3.x and Novell NetWare. If your software or hard disk does not support this function, set this parameter to *Disabled*.

2.2.6 Large Memory Support Mode

The available setting for this parameter are *Normal* and *Advanced*. Set this parameter to *Advanced* if you are working under Windows NT 3.1 environment. The setting allows you to support an extended memory higher than 64 MB. The default setting is *Normal*.

2.2.7 Num Lock After Boot

This parameter allows you to activate the Num Lock function upon booting. The default setting is *Enabled*.

2.2.8 Memory Test

When set to *Enabled*, this parameter allows the system to perform a RAM test during the POST routine. When set to *Disabled*, the system detects only the memory size and bypasses the test routine. The default setting is *Disabled*.

2.2.9 Quiet Boot

This parameter enables or disables the quiet boot function. When set to *Enabled*, BIOS is in graphical mode and displays only an identification logo during POST and while booting. After which the screen displays the operating system prompt (such as DOS) or logo (such as Windows 95). If any error occurred while booting, the system automatically switches to the text mode.

Even if your setting is `Enabled`, you may also switch to the text mode while booting by pressing `F9` after you hear a beep that indicates the activation of the keyboard.

When set to `Disabled`, BIOS is in the conventional text mode where you see the system initialization details on the screen.

2.2.10 Configuration Table

This parameter allows you to display the configuration table after POST but before booting. The configuration table gives a summary of the hardware devices and settings that BIOS detected during POST. Following is a sample configuration table.

CPU/CLK	: Pentium/133 MHz	Base Memory:	: xxx KB
Math Coprocessor:	Installed	Extended Memory:	xxxx KB
IDE Drive 0	: xxx MB	Shadow RAM	: xxx KB
IDE Drive 1	: xxx MB	Internal Cache	: xxx KB, Enabled
IDE Drive 2	: xxx MB	External Cache	: xxx KB, Enabled
IDE Drive 3	: xxx MB	Serial Port(s)	: 3F8h, 2F8h
Diskette Drive A:	xx-MB, xx-inch	Parallel Port	: 378h
Diskette Drive B:	None	Pointing Device:	None

2.3 Advanced System Configuration

The Advanced System Configuration option allows you to configure the advanced system memory functions.



Do not change any settings in the Advanced Configuration if you are not a qualified technician to avoid damaging system.

The following screen shows page one of the Advanced System Configuration parameters.

Advanced System Configuration		Page 1/1
*Internal Cache (CPU Cache).....	[Enabled]	
*External Cache.....	[Enabled]	
*Cache Scheme.....	[Write Back]	
ECC/Parity Mode Selection.....	[Disabled]	
Memory at 15MB-16MB Reserved for....	[System] Use	

↓ = Move Highlight Bar, → ← = Change Setting
PgDn/PgUp = Move Screen, F1 = Help, Esc = Exit



The grayed parameters (denoted with asterisks) are not user-configurable.

2.3.1 Internal Cache (CPU Cache)

This parameter enables or disables the internal cache memory.

2.3.2 External Cache

This parameter enables or disables the external cache memory.

Cache Scheme

This parameter fixes the cache setting to `Write-back mode`. `Write-back` updates the cache but not the memory when there is a write instruction. It updates the memory only when there is an inconsistency between the cache and the memory.

2.3.3 ECC/Parity Mode Selection

This parameter allows you to enable or disable the ECC and parity check feature.

The `ECC` option, ECC detects of both single-bit and multiple-bit errors but corrects only single-bit errors. The `Parity` option allows parity check. If it detects any parity errors, it signals the operating system of the parity error detection.

Disable this parameter if you installed SIMMs without parity.

2.3.4 Memory at 15MB-16MB

To prevent memory address conflicts between the system and expansion boards, reserve this memory range for the use of either the system or an expansion board. Before setting this parameter, check your add-on card manual to determine if your add-on card needs this memory space. If not, set this parameter to `System Use`.

2.4 Power Saving Configuration

The Power Saving Configuration parameters are configurable only if your system supports the power management feature.

The following screens show the Power Saving Configuration parameters and their default settings:

```
Power Saving Configuration                               Page 1/1

Power Management Mode .....[Enabled ]
*Monitor Power Saving Timer .....[15] Minute(s)
*IDE Hard Disk Standby Timer .....[15] Minute(s)
*System Standby Timer .....[OFF]
*System Suspend Timer .....[OFF]

Monitored Activities
IRQ 2/IRQ 9...[Disabled]      DRQ 0.....[Disabled]
IRQ 3.....[Disabled]         DRQ 1.....[Disabled]
IRQ 4.....[Disabled]         DRQ 3.....[Disabled]
IRQ 5.....[Disabled]         DRQ 5.....[Disabled]
IRQ 7.....[Disabled]         DRQ 6.....[Disabled]
IRQ 10.....[Disabled]        DRQ 7.....[Disabled]
IRQ 11.....[Disabled]
*IRQ 12.....[Enabled ]
*IRQ 15.....[Enabled ]

↓ = Move Highlight Bar,   → ← = Change Setting
PgDn/PgUp = Move Screen,  F1 = Help,   Esc = Exit
```

2.4.1 Power Management Mode

This parameter allows you to reduce power consumption. When this parameter is set to *Enabled*, you can configure the monitor, IDE hard disk, and system timers. Setting to *Disabled* deactivates the power management feature and all the timers.

Monitor Power Saving Timer

This parameter sets the VESA DPMS-compatible display monitor to standby mode. Any keyboard or mouse action returns the monitor to normal operation.

IDE Hard Disk Standby Timer

This parameter allows the hard disk to enter standby mode after inactivity of 1 to 15 minutes, depending on your setting. When you access the hard disk again, allow 3 to 5 seconds (depending on the hard disk) for the disk to return to normal speed. Set this parameter to *Off* if your hard disk does not support this function.

System Standby Timer

This parameter sets the system to a "fast-on" power saving mode. It automatically enters the standby mode after a specified period of inactivity. Any keyboard or mouse action, or any enabled monitored activities occurring through IRQ or DRQ channels, resume system operation. See section 2.4.2.

System Suspend Timer

This parameter supports the lowest power saving mode. To resume system operation from suspend mode, you can either press a key, move the mouse or press the reset button. If you run network, set this item to *OFF*.

2.4.2 Monitored Activities

The IRQ items under this parameter allow you to monitor system activities occurring through the IRQ channels. The enabled parameters indicate specific system activities that wake up the system from power saving mode.

For example, if you assign IRQ 3 to a fax/modem and you set this item to *Enabled*, any fax/modem activity wakes up the system.

2.5 System Security Setup

The Setup program has a number of security features to prevent unauthorized access to the system and its data.

Enter the Setup program and select System Security. The following screen appears:

```
System Security                                     Page 1/1
Disk Drive Control
Diskette Drive.....[      Normal      ]
Hard Disk Drive.....[      Normal      ]
System Boot Drive.....[Drive A then C]
Boot from CD-ROM.....[Disabled]
Onboard Communication Ports
Serial Port 1 Base Address.....[ 3F8h  ]
Serial Port 2 Base Address.....[ 2F8h  ]
Parallel Port Base Address.....[378 (IRQ 7)]
Operation Mode.....[Enhanced Parallel Port (EPP)] Mode
*ECP DMA Channel.....[-]
Onboard PS/2 Mouse (IRQ 12).....[Enabled ]
Setup Password.....[ None ]
Power On Password.....[ None ]

↓ = Move Highlight Bar,   → ← = Change Setting
PgDn/PgUp = Move Screen,   F1 = Help,   Esc = Exit
```

2.5.1 Disk Drive Control

The disk drive control features allow you to enable or disable the read/write functions of a disk drive. These features can also control the diskette drive or the hard disk drive boot function to prevent loading operating systems or other programs from a certain drive while the other drives are operational.

Table 2-1 lists the drive control settings and their corresponding functions.

Table 2-1 Drive Control Settings

Setting	Description
Diskette Drive	
Normal	Diskette drive functions normally
Write Protect All Sectors	Disables the write function on all sectors
Write Protect Boot Sector	Disables the write function only on the boot sector
Disabled	Disables all diskette functions
Hard Disk Drive	
Normal	Hard disk drive functions normally
Write Protect All Sectors	Disables the write function on all sectors
Write Protect Boot Sector	Disables the write function only on the boot sector
Disabled	Disables all hard disk functions
System Boot Drive	
Drive A then C	The system checks drive A first. If there is a diskette in the drive, the system boots from drive A. Otherwise, it boots from drive C.
Drive C then A	The system checks drive C first. If there is a hard disk (drive C) installed, the system boots from drive C. Otherwise, it boots from drive A.
C:	The system always boots from drive C.
A:	The system always boots from drive A.
Boot from CD-ROM	
Enabled	The system looks for a bootable CD in the CD-ROM. If a CD is present, the system boots from the CD-ROM. Otherwise, it boots from the drive specified in the System Boot drive parameter.
Disabled	System boots from the drive specified in the System Boot Drive parameter.

2.5.2 Onboard Communication Ports

Serial Port 1 Base Address

This parameter allows you to set the serial port 1 logical base address.

Table 2-2 Serial Port 1 Settings

Setting	Description
3F8h	Serial port 1 with address 3F8h using IRQ4
2F8h	Serial port 1 with address 2F8h using IRQ3
3E8h	Serial port 1 with address 3E8h using IRQ4
2E8h	Serial port 1 with address 2E8h using IRQ3
Disabled	Disables serial port 1

Serial Port 2 Base Address

This parameter allows you to set the serial port 2 logical base address.

Table 2-3 Serial Port 2 Settings

Setting	Description
3F8h	Serial port 2 with address 3F8h using IRQ4
2F8h	Serial port 2 with address 2F8h using IRQ3
3E8h	Serial port 2 with address 3E8h using IRQ4
2E8h	Serial port 2 with address 2E8h using IRQ3
Disabled	Disables serial port 2



If you assign 3F8h to serial port 1, you may only assign 2F8h or 2E8h to serial port 2.

If you assign 2F8h to serial port 1, you may only assign 3F8h or 3E8h to serial port 2.

Parallel Port Base Address

The system has one parallel port. Table 2-4 lists the options for selecting the parallel port address. You also have the option to disable the parallel port.

Table 2-4 Parallel Port Settings

Setting	Function
3BCh (IRQ 7)	Corresponds to the parallel port with address 3BCh
378h (IRQ 7)	Corresponds to the parallel port with address 378h
278h (IRQ 5)	Corresponds to the parallel port with address 278h
Disabled	Disables the parallel port

To deactivate the parallel port, select the *Disabled* option. If you install an add-on card that has a parallel port whose address conflicts with the parallel port onboard, the system automatically disables the onboard functions.

Check the parallel port address on the add-on card and change the address to one that does not conflict.

OPERATION MODE

This item allows you to set the operation mode of the parallel port. Table 2-5 lists the different operation modes.

Table 2-5 Parallel Port Operation Mode Settings

Setting	Function
Standard Parallel Port (SPP)	Allows normal speed one-way operation
Standard and Bidirectional	Allows normal speed operation in a two-way mode
Enhanced Parallel Port (EPP)	Allows bidirectional parallel port operation at maximum speed
Extended Capabilities Port (ECP)	Allows parallel port to operate in bidirectional mode and at a speed higher than the maximum data transfer rate

ECP DMA CHANNEL

This item becomes active only if you select `Extended Capabilities Port (ECP)` as the operation mode. It allows you to select DMA channel 1 or DMA channel 3 (as required in Windows95).



2.5.3 Onboard PS/2 Mouse (IRQ 12)

This parameter enables or disables the onboard PS/2 mouse. When set to `Enabled`, it allows you to use the onboard PS/2 mouse assigned with IRQ12. When set to `Disabled`, it deactivates the mouse and frees IRQ12 for the use of other devices.

2.5.4 Setup Password

The Setup Password prevents unauthorized access to the BIOS utility.

Setting a Setup Password

1. Enter BIOS utility and select System Security.
2. Highlight the Setup Password parameter and press the  or  key. The password prompt appears:

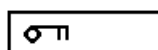





3. Type a password. The password may consist of up to seven characters.

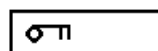
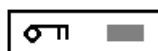

Be very careful when typing your password because the characters do not appear on the screen.

4. Press . A prompt asks you to retype the password to verify your first entry.



5. Retype the password then press .
After setting the password, the system automatically sets the Setup Password parameter to `Present`.
6. Press  to exit the System Security screen and return to the main menu.
7. Press  to exit the BIOS utility. A dialog box appears asking if you want to save the CMOS data.

-
8. Select Yes to save the changes and reboot the system.







The next time you want to enter the BIOS utility, you must key-in your Setup password.



Write your password down and keep it in a safe place.

Changing or Removing the Setup Password

Should you want to change your setup password, do the following:

1. Enter the BIOS utility and select System Security.
2. Highlight the Setup Password parameter.
3. Press the  or  key to display the password prompt and key-in a new password.
or
Press the  or  key and select None to remove the existing password.
4. Press  to exit the System Security screen and return to the main menu.
5. Press  to exit the BIOS utility. A dialog box appears asking if you want to save the CMOS data.
6. Select Yes to save the changes and reboot the system.

If You Forget the Password

If you forget your password, clear the CMOS settings. To clear the CMOS settings, take the battery out for two hours. Put the battery back after this time to load the CMOS default settings.

Call your dealer or a qualified technician if you are not confident to perform the above procedure.

2.5.5 Power On Password

The power on password secures your system against unauthorized use. Once you set this password, you have to type it whenever you boot the system.

To set a power on password, highlight the Power On Password parameter and follow the same procedure as in setting a setup password. See section 2.5.4.

2.6 PnP/PCI System Configuration

The PnP/PCI System Configuration allows you to specify the settings for your PCI devices.

PnP/PCI System Configuration		Page 1/1			
PCI IRQ Setting[Auto]					
		INTA	INTB	INTC	INTD
*PCI Slot 1.....	[--]	[--]	[--]	[--]	[--]
*PCI Slot 2.....	[--]	[--]	[--]	[--]	[--]
*PCI Slot 3.....	[--]	[--]	[--]	[--]	[--]
*PCI Slot 4.....	[--]	[--]	[--]	[--]	[--]
PCI IRQ Sharing.....[Yes]					
VGA Palette Snoop[Disabled]					
Plug & Play OS.....[Yes]					
Reset Resources Assignment..[No]					
↓ = Move Highlight Bar, → ← = Change Setting PgDn/PgUp = Move Screen, F1 = Help, Esc = Exit					

2.6.1 PCI IRQ Setting





This parameter allows for Auto or Manual configuration of PCI devices. If you use plug-and-play (PnP) devices, you can keep the default setting Auto. The system then automatically configures the PnP devices. If your PCI device is not a PnP, you can manually assign the interrupt for each of the device.



Refer to your manual for technical information about the PCI card.

PCI Slots

These parameters allow you to specify the appropriate interrupt for each of the PCI devices. You can assign IRQ5, IRQ9, IRQ10, IRQ11, or IRQ15 to the slots.

Press  or  to move between fields. Press  or  to select options.

2.6.2 PCI IRQ Sharing

When set to *Yes*, this parameter allows you to assign the same IRQ to more than one PCI device installed in the system. When set to *No*, you must assign different IRQs to the PCI devices.

2.6.3 VGA Palette Snoop

This parameter permits you to use the palette snooping feature if you installed more than one VGA card in the system.

The VGA palette snoop function allows the control palette register (CPR) to manage and update the VGA RAM DAC (Digital Analog Converter, a color data storage) of each VGA card installed in the system. The snooping process lets the CPR send a signal to all the VGA cards so that they can update their individual RAM DACs. The signal go through the cards continuously until all RAM DAC data have been updated. This allows display of multiple images on the screen.



Some VGA cards have required settings for this feature. Check your VGA card manual before setting this parameter.

2.6.4 Plug & Play OS

When this parameter is set to *Yes*, BIOS initializes only PnP boot devices such as SCSI cards. When set to *No*, BIOS initializes all PnP boot and non-boot devices such as sound cards.



*Set this parameter to *Yes* only if your operating system is Windows 95.*

2.6.5 Reset Resources Assignment

Set this parameter to *Yes* to avoid IRQ conflict when installing non-PnP or PnP ISA cards. This clears all resource assignments and allows BIOS to reassign resources to all installed devices the next time the system boots. After clearing the resource data, the parameter resets to *No*.

Refer to section 1.9 for instructions on installing and configuring ISA cards.

2.7 Load Setup Default Settings

Use this option to load the default settings for the optimized system configuration. When you load the default settings, some of the parameters are grayed-out with their fixed settings. These grayed parameters are not user-configurable.

The following dialog box appears when you select Load Setup Default Settings from the main menu.

```
Load Setup Default Settings
Are you sure

      [Yes]      [No]
```

Select [Yes] to load the default settings.

2.8 Leaving Setup

Examine the system configuration values. When you are satisfied that all the values are correct, write them down. Store the recorded values in a safe place. In the future, if the battery loses power or the CMOS chip is damaged, you will know what values to enter when you rerun Setup.

Press **[ESC]** to leave the system configuration setup. If there is any change in the BIOS utility functions, the following screen appears:

```
Do you want to save CMOS data?

      [Yes]      [No]
```

Use the arrow keys to select your response. Select **Yes** to store the new data in CMOS. Select **No** to retain the old configuration values. Press .