

This publication, including photographs, illustrations and software, is under the protection of international copyright laws, with all rights reserved. Neither this manual, nor any of the material contained herein, may be reproduced without the express written consent of the manufacturer.

The information in this document is subject to change without notice. The manufacturer makes no representations or warranties with respect to the contents hereof and specifically disclaims any implied warranties of merchantability or fitness for any particular purpose. Further, the manufacturer reserves the right to revise this publication and to make changes from time to time in the content hereof without obligation of the manufacturer to notify any person of such revision or changes.

Trademarks

IBM, VGA, and PS/2 are registered trademarks of International Business Machines.

Intel, Pentium, Pentium-II, Pentium-III, Pentium 4, MMX, Celeron and Tualatin are registered trademarks of Intel Corporation.

Microsoft, MS-DOS and Windows 98/ME/NT/2000/XP are registered trademarks of Microsoft Corporation.

PC-cillin is a trademark of Trend Micro Inc.

AMI is a trademark of American Megatrends Inc.

MediaRing Talk is a registered trademark of MediaRing Inc.

3Deep is a registered trademark of E-Color Inc.

It has been acknowledged that all mentioned brands or product names are trademarks or registered trademarks of their respective holders.

**Copyright © 2003
All Rights Reserved
M950 Series, V3.3
P4X400/May 2003**

Notice:

1. Owing to Microsoft's certifying schedule is various to every supplier, we might have some drivers not certified yet by Microsoft. Therefore, it might happen under Windows XP that a dialogue box (shown as below) pop out warning you this software has not passed Windows Logo testing to verify its compatibility with Windows XP. Please rest assured that our RD department has already tested and verified these drivers. Just click the "Continue Anyway" button and go ahead the installation.

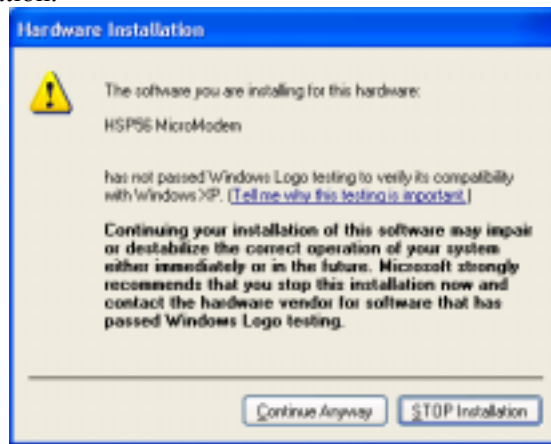

2. USB 2.0 Driver Limitations:
 - 2-1 The USB 2.0 driver only supports Windows XP and Windows 2000.
 - 2-2 If you connect a USB 2.0 hub to the root hub, plugging USB devices into this hub, the system might not successfully execute certain USB devices' connection because it could not recognize these devices.

Table of Contents

Chapter 1: Introduction	1
Key Features	2
Package Contents	5
Static Electricity Precautions	6
Pre-Installation Inspection	6
Chapter 2: Mainboard Installation	7
Mainboard Components	8
I/O Ports	8
Installing the Processor	9
Installing Memory Modules	10
Jumper Settings	11
Install the Mainboard	12
The Panel Connector	13
Other Devices Installation	14
Expansion Slots Installation	15
Connecting Optional Devices	16
Chapter 3: BIOS Setup Utility	18
Introduction	18
Running the Setup Utility	19
Standard CMOS Setup Page	20
Advanced Setup Page	21
Power Management Setup Page	24
PCI/Plug and Play Setup Page	25
Load Optimal Settings	26
Load Best Performance Settings	26
Features Setup Page	27
CPU PnP Setup Page	28
Hardware Monitor Page	29
Change Password	29
Exit	30
Chapter 4: Software & Applications	31
Introduction	31
Installing Support Software	32
Bundled Software Installation	34
Hyper Threading CPU	35

Chapter 1

Introduction

This mainboard has a **Socket-478** supporting **Intel Pentium 4/Hyper Threading Technology** processors with front-side bus (FSB) speeds up to **533 MHz**. Hyper Threading Technology, designed to take advantage of the multitasking features in Windows XP, gives you the power to do more things at once.

This mainboard has the **VIA P4X400** Northbridge and VT8235 Southbridge chipsets that support **AC 97 audio codec**, and provide **Ultra DMA 33/66/100/133** function. It supports built-in **USB 2.0** providing higher bandwidth. It implements **Universal Serial Bus Specification Revision 2.0** and is compliant with **UHCI 1.1** and **EHCI 0.95**. This mainboard has five 32-bit **PCI** slots, one **8xAGP** slot, one **CNR** (Communications and Networking Riser) slot, and an onboard **10BaseT/100BaseTX Network** interface (optional). This mainboard has a full set of I/O ports including two PS/2 ports for mouse and keyboard, one serial port, one parallel port and maximum six USB 2.0 ports— four back-panel ports and onboard USB header USB2 providing two extra ports by connecting the Extended USB Module to the mainboard.

This mainboard is an **ATX size** mainboard and has power connectors for an ATX power supply.

Note: You must initiate the HT CPU function through BIOS setup. It is strongly recommended you refer to the Appendix (page 35) for relative details.

Key Features

This mainboard has these key features:

Socket 478 Processor

- ◆ The PGA Socket 478
- ◆ Supports **Intel Pentium 4 series** CPU with/without **Hyper Threading** Technology
- ◆ Supports a front-side bus (FSB) of **533** MHz

Chipset

There are **VIA P4X400** Northbridge and **VT8235** Southbridge in this chipset in accordance with an innovative and scalable architecture with proven reliability and performance.

- ◆ Provide superior performance between the CPU, DRAM, V-Link bus and AGP8X graphics controller bus with pipelined, burst, and concurrent operation.
- ◆ Provide a 533MB/sec bandwidth Host/Client V-Link interface with V-Link-PCI and V-Link-LPC controllers
- ◆ Support five PCI slots of arbitration and decoding for all integrated functions and LPC bus.

Memory Support

- ◆ The mainboard accommodates two DDR 184 pin, 2.5V DIMM sockets with a total capacity of 2 GB system memory.
- ◆ Supports DDR 266/**333** MHz memory bus

Built-in Graphics System

- ◆ AGP v3.0 compliant with 8x transfer mode compliant with AGP 8x specification 0.9.
- ◆ AGP pipelined split-transaction long-burst transfers up to 1GB/sec
- ◆ Intelligent request reordering for maximum AGP bus utilization
- ◆ Supports Flush/Fence commands

- ◆ Graphics Address Relocation Table (GART)
 - One level TLB Structure
 - Sixteen entry fully associative page table
 - LRU replacement scheme
 - Independent GART lookup control for host/AGP/PCI master accesses

AC'97 Audio Codec

- ◆ Compliant with AC'97 2.1 specification
- ◆ 16-bit stereo full-duplex CODEC with fixed 48KHz sampling rate
- ◆ 3 analog line-level stereo inputs with 5-bit volume control: LINE-IN, CD-IN, AUX-IN
- ◆ 1 analog line-level mono input: PHONE-IN
- ◆ Three Audio Jacks – Line-Out, Line-In and Microphone-In
- ◆ Sound Blaster, Sound Blaster Pro Compatible
- ◆ Digital I/O compatible with consumer mode S/PDIF
- ◆ Advanced power management support

Expansion Options

The mainboard comes with the following expansion options:

- ◆ Five 32-bit PCI slots capable of Ultra DMA bus mastering with transfer rates of 33/66/100/133 MB/sec
- ◆ One 8xAGP slot
- ◆ One CNR (Communications and Networking Riser) slot

Onboard I/O Ports

The mainboard has a full set of I/O ports and connectors:

- ◆ Two PS/2 ports for mouse and keyboard
- ◆ One serial port
- ◆ One parallel port
- ◆ Six USB 2.0 ports (four back-panel ports, onboard USB header providing two extra ports)
- ◆ Audio jacks for microphone, line-in and line-out

BIOS Firmware

This mainboard uses AMI BIOS that enables users to configure many system features including the following:

- ◆ Power management
- ◆ Wake-up alarms
- ◆ CPU parameters and memory timing
- ◆ CPU and memory timing

The firmware can also be used to set parameters for different processor clock speeds.

USB 2.0

- ◆ Compliant with Universal Serial Bus Specification Revision 2.0
- ◆ Compliant with Intel's Enhanced Host Controller Interface Specification Revision 0.95
- ◆ Compliant with Universal Host Controller Interface Specification Revision 1.1
- ◆ PCI multi-function device consists of two **UHCI Host Controller** cores for full-/low-speed signaling and one **EHCI Host Controller** core for high-speed signaling
- ◆ Root hub consists 4 downstream facing ports with integrated physical layer transceivers shared by **UHCI** and **EHCI** Host Controller
- ◆ Support PCI-Bus Power Management Interface Specification release 1.1
- ◆ Legacy support for all downstream facing ports

Built-in Ethernet LAN (Optional)

- ◆ **100Base-TX/10Base-T Physical Layer Solution**
- ◆ Dual Speed – 100/10 Mbps
- ◆ MII Interface to Ethernet Controller/Configuration & Status
- ◆ Auto Negotiation: 10/100, Full/Half Duplex
- ◆ Meet All Applicable IEEE802.3, 10Base-T and 100Base-TX Standards

Bundled Software

- ◆ **PC-Cillin 2002** provides automatic virus protection under Windows 98/ME/NT/2000/XP
- ◆ **MediaRing Talk** provides PC to PC or PC to Phone internet phone communication
- ◆ **3Deep** delivers the precise imagery and displays accurate color in your monitor
- ◆ **PC DJ** is a dual-MP3 player that enables users to actually mix music right on their own personal computers.
- ◆ **Adobe Acrobat Reader V5.0** is the software to help users read .PDF files.

Dimensions

- ◆ ATX form factor of 305 x 220 mm

Note: Hardware specifications and software items are subject to change without notification.

Package Contents

Attention: This mainboard serial has two models, M950HLU (Hyper Threading CPU, LAN, USB2.0) and M950HU (Hyper Threading CPU, USB 2.0).

Please contact your local supplier for more information about your purchased model. Each model will support different specification listed as below:

Model	Specification
M950HLU	Hyper Threading CPU, Onboard LAN PHY chip (U13), USB + RJ-45 LAN connector
M950HU	Hyper Threading CPU, USB connector only

Your mainboard package contains the following items:

- The mainboard
- The User's Manual
- One diskette drive ribbon cable (optional)
- One IDE drive ribbon cable
- Software support CD

Optional Accessories

You can purchase the following optional accessories for this mainboard.

- ❑ Extended USB module
- ❑ CNR v.90 56K Fax/Modem card
- ❑ Card Reader (You can buy your own Card Reader from the third party, but please contact your local Card Reader vendor on any issues of the specification and compatibility.)

Static Electricity Precautions

Static electricity could damage components on this mainboard. Take the following precautions while unpacking this mainboard and installing it in a system.

1. Don't take this mainboard and components out of their original static-proof package until you are ready to install them.
2. While installing, please wear a grounded wrist strap if possible. If you don't have a wrist strap, discharge static electricity by touching the bare metal of the system chassis.
3. Carefully hold this mainboard by its edges. Do not touch those components unless it is absolutely necessary. Put this mainboard on the top of static-protection package with component side facing up while installing.

Pre-Installation Inspection

1. Inspect this mainboard whether there are any damages to components and connectors on the board.
2. If you suspect this mainboard has been damaged, do not connect power to the system. Contact your mainboard vendor about those damages.

Chapter 2

Mainboard Installation

To install this mainboard in a system, please follow these instructions in this chapter:

- ❑ Identify the mainboard components
- ❑ Install a CPU
- ❑ Install one or more system memory modules
- ❑ Make sure all jumpers and switches are set correctly
- ❑ Install this mainboard in a system chassis (case)
- ❑ Connect any extension brackets or cables to connecting headers on the mainboard
- ❑ Install other devices and make the appropriate connections to the mainboard connecting headers.

Note:

1. Before installing this mainboard, make sure jumper JBAT1 is under Normal setting. See this chapter for information about locating JBAT1 and the setting options.
2. Never connect power to the system during installation; otherwise, it may damage the mainboard.

Mainboard Components

Identify major components on the mainboard via this diagram underneath.

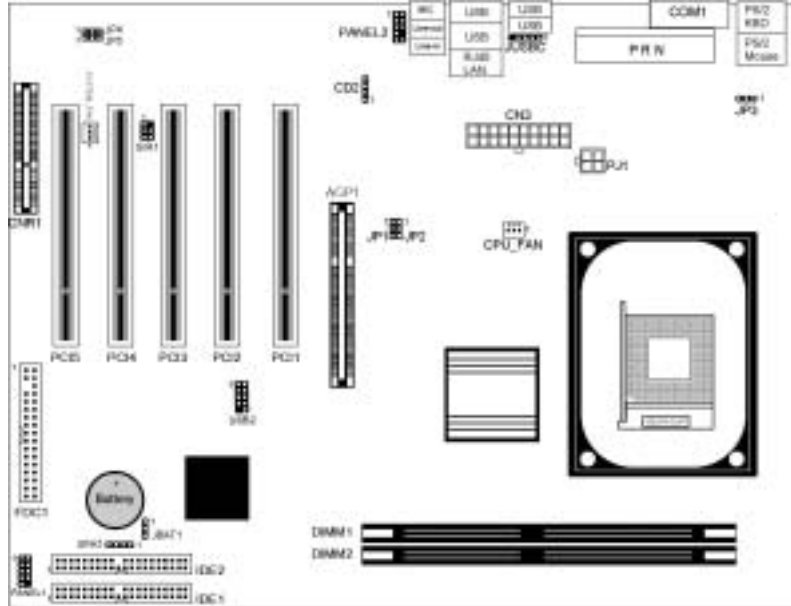

Note: Any jumpers on the mainboard that do not appear in this illustration are for testing only.

I/O Ports

The illustration below shows a side view of the built-in I/O ports on the mainboard.

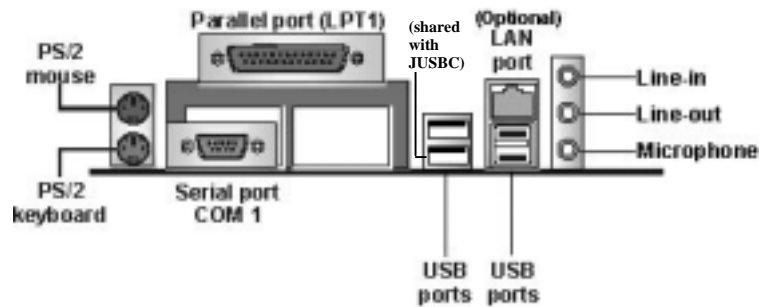

PS/2 Mouse	Use the upper PS/2 port to connect a PS/2 pointing device.
PS/2 Keyboard	Use the lower PS/2 port to connect a PS/2 keyboard.
Parallel Port (LPT1)	Use LPT1 to connect printers or other parallel communications devices.
COM1	Use the COM port to connect serial devices such as mice or fax/modems. COM1 is identified by the system as COM1.
LAN Port (Optional)	Connect an RJ-45 jack to the LAN port to connect your computer to the Network.
USB Ports	Use the USB ports to connect USB devices. <i>Note: The lower USB port located near the Parallel port is shared with the JUSBC connector.</i>
Audio Ports	Use the three audio ports to connect audio devices. The first jack is for stereo Line-In signal. The second jack is for stereo Line-Out signal. The third jack is for Microphone.

Installing the Processor

This mainboard has a Socket 478 processor socket. When choosing a processor, consider the performance requirements of the system. Performance is based on the processor design, the clock speed and system bus frequency of the processor, and the quantity of internal cache memory and external cache memory.

CPU Installation Procedure

Follow these instructions to install the CPU:

1. Unhook the CPU socket's locking lever by pulling it away from socket and raising it to the upright position.
2. Match the pin 1 corner of CPU socket to the one of processor, and insert the processor into the socket. Do not use force.
3. Push the locking lever down and hook it under the latch on the edge of socket.
4. Apply thermal grease to the top of the CPU.

5. Lower the CPU fan/heatsink unit onto the CPU and CPU socket, and then use the retention module clamps to snap the fan/heatsink into place.
6. Plug the CPU fan power cable into the CPU cooling fan power supply connector on the mainboard.

Installing Memory Modules

This mainboard accommodates two 184-pin 2.5V unbuffered Double Data Rate SDRAM (DDR SDRAM) Dual Inline Memory Module (DIMM) sockets, and supports up to 2.0 GB of 200/266/333 MHz DDR SDRAM.

DDR SDRAM is a type of SDRAM that supports data transfers on both edges of each clock cycle (the rising and falling edges), effectively doubling the memory chip's data throughput. DDR DIMMs can synchronously work with 100MHz, 133MHz or 166MHz memory bus.

DDR SDRAM provides 1.6 GB/s or 2.1 GB/s data transfer rate depending on whether the bus is 100 MHz or 133 MHz. DDR SDRAM uses additional power and ground lines and requires 184-pin 2.5V unbuffered DIMM module.

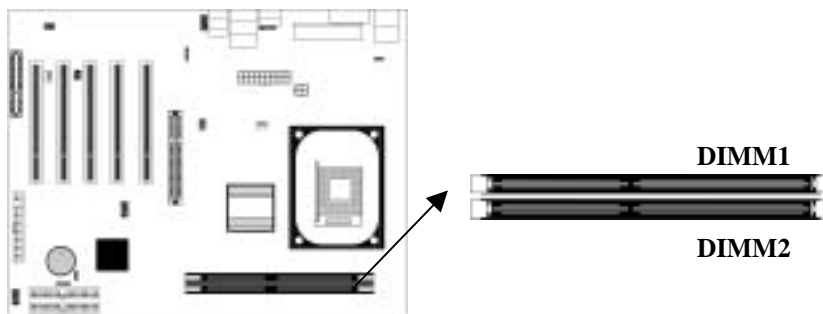

Installation Procedure

These modules can be installed with up to 2 GB system memory. Refer to the following to install the memory module.

1. Push the latches on each side of the DIMM socket down.
2. Align the memory module with the socket. The DIMM sockets are keyed with notches and the DIMMs are keyed with cutouts so that they can only be installed correctly.
3. Check that the cutouts on the DIMM module edge connector match the notches in the DIMM socket.
4. Install the DIMM module into the socket and press it firmly down until it is seated correctly. The socket latches are levered upwards and latch on to the edges of the DIMM.
5. Install any remaining DIMM modules.

Jumper Settings

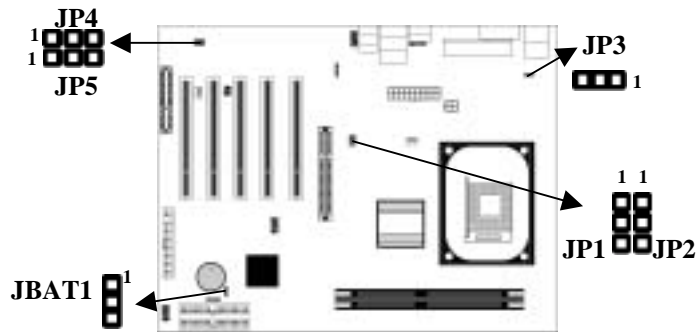

JBAT1: Clear CMOS Jumper

This jumper is to clear the contents of CMOS memory. You may need to clear the CMOS memory if the settings in the Setup Utility are incorrect that prevents your mainboard from operating. To clear the CMOS memory, disconnect all the power cables from the mainboard and then move the jumper cap into the CLEAR setting for a few seconds.

Function	Jumper Setting
Normal	Short Pins 1-2
Clear CMOS	Short Pins 2-3

JP1, JP2: CPU Clock Selector

This jumper enables to select CPU frequency.

CPU Clock	JP1	JP2
100M	Short Pins 1-2	Short Pins 2-3
133M	Short Pins 2-3	Short Pins 1-2

JP3: Keyboard Power On/Off

If the Keyboard Power On is enabled, hot keys on the keyboard can work as a power on/off switch for the system.

Function	Jumper Setting
Disabled	Short Pins 1-2
Enabled	Short Pins 2-3

Note: The system must supply at least 1A on the +5VSB (+5V Standby) signal before enabling the Keyboard Power On function.

JP4: Flash ROM Size Selector

This jumper enables to select size of flash ROM.

Function	Jumper Setting
2M	Short Pins 1-2
4M	Short Pins 2-3

JP5: Flash ROM Voltage (VCC) Selector

This jumper enables to select voltage of flash ROM.

Function	Jumper Setting
5V	Short Pins 1-2
3V	Short Pins 2-3

Install the Mainboard

Install the mainboard in a system chassis (case). The board is an ATX size mainboard. You can install this mainboard in an ATX case. Make sure your case has an I/O cover plate matching the ports on this mainboard.

Install the mainboard in a case. Follow the case manufacturer's instructions to use the hardware and internal mounting points on the chassis.

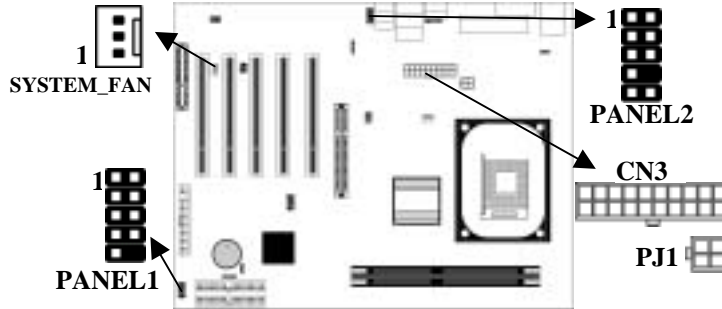

Connect power supply to the **CN3** connector on the mainboard. **PJ1** is the CPU Vcore power connector.

If there is a cooling fan in the system chassis, connect the cooling fan cable to the **SYSTEM_FAN** fan power connector on the mainboard.

The Panel Connector

PANEL1

This panel connector provides a set of switch and LED connectors found on ATX case. Refer to the table below for information.

Device	Pins
Empty	10
N/C	9
Power ON/OFF	6, 8
Reset Switch	5, 7
SPD-LED Indicator	+2, 4
HDD LED	+1, -3

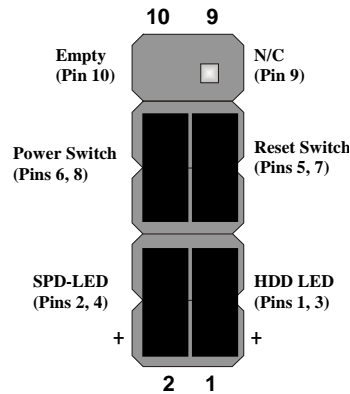

PANEL2

If there are a headphone jack or/and a microphone jack on the front panel, connect the cables to the PANEL2 on the mainboard.

Device	Pins
Line Out (L)	9, 10
Empty	8
NC	7
Line Out (R)	5, 6
+5V Audio	4
VCCMIC	3
GND	2
MIC IN	1

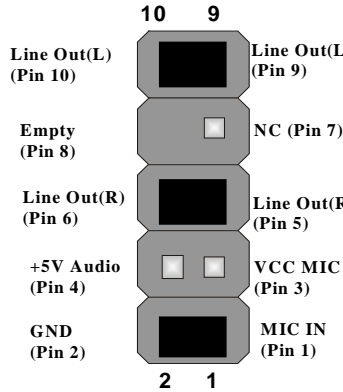

Other Devices Installation

Floppy Diskette Drive Installation

The mainboard has a floppy diskette drive (FDD) interface and ships with a diskette drive ribbon cable that supports one or two floppy diskette drives. You can install a 5.25-inch drive and a 3.5-inch drive with various capacities. The floppy diskette drive cable has one type of connector for a 5.25-inch drive and another type of connector for a 3.5-inch drive.

IDE Devices

Your mainboard has a primary and secondary IDE channel interface (IDE1 and IDE2). An IDE ribbon cable supporting two IDE devices is bundled with the mainboard.

If you want to install more than two IDE devices, get a second IDE cable and you can add two more devices to the secondary IDE channel.

IDE devices have jumpers or switches to set the IDE device as MASTER or SLAVE. When installing two IDE devices on one cable, ensure that one device is set to MASTER and the other one to SLAVE.

This mainboard supports Ultra DMA 66/100/133. UDMA is a technology to accelerate devices' performance in the IDE channel. To maximize performance, install IDE devices that support UDMA and use 80-pin IDE cables supporting UDMA 66/100/133.

Expansion Slots Installation

This mainboard has one 8xAGP, one CNR and five 32-bit PCI (Peripheral Components Interconnect) expansion slots.

8 x AGP (Accelerated Graphics Port) Slot

You can install a graphics adapter supporting 8xAGP specification in the AGP slot. This slot has one 8xAGP edge connector.

CNR (Communications Networking Riser) Slot

You can install a CNR (the Communications Networking Riser) card in the CNR slot.

PCI (Peripheral Components Interconnect) Slot

You can install the 32-bit PCI interface expansion cards in the slots.

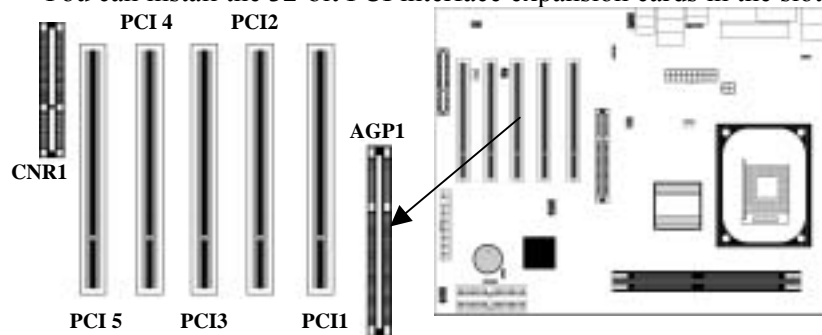

1. Remove a blanking plate from the system case corresponding to the slot you are going to use.
2. Install the edge connector of the expansion card into the expansion slot. Ensure that the edge connector is correctly seated in the slot.
3. Secure the metal bracket of the card to the system case with a screw.

Connecting Optional Devices

Refer to the following for information on connecting the mainboard's optional devices:

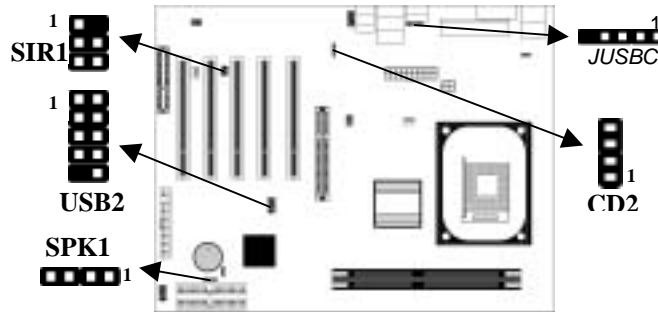

SPK1: Speaker Connector

Connect the cable from the PC speaker to the SPK1 header on the mainboard.

Pin	Signal	Pin	Signal
1	SPKR	2	NC
3	GND	4	+5V

USB2: Front panel USB header

The mainboard has USB ports installed on the rear edge I/O port array. Some computer cases have a special module that mounts USB ports at the front of the case. If you have this kind of case, use auxiliary USB connectors USB2 to connect the front-mounted ports to the mainboard.

Pin	Signal	Pin	Signal
1	VERG_FP_USBPWR0	2	VERG_FP_USBPWR0
3	USB_FP_P0-	4	USB_FP_P1-
5	USB_FP_P0+	6	USB_FP_P1+
7	GROUND	8	GROUND
9	KEY	10	USB_FP_OC0

JUSBC: USB Card Reader Connector (optional)

This connector is for connecting internal USB card reader. You can use a card reader to read or transfer files and digital images to your computer.

Pin	Signal	Pin	Signal
1	VCC	2	USB-
3	USB+	4	GND
5	KEY		

! The READ1 is shared with one of the USB ports of the I/O back panel. The USB port is located near the Parallel port connector. See “I/O Ports” for more information.

! Please check the pin assignment of the cable and the USB header on the mainboard. Make sure the pin assignment will match before plugging in. Any incorrect usage may cause unexpected damage to the system. The vendor won't be responsible for any incidental or consequential damage arising from the usage or misuse of the purchased product.

CD2: CD-ROM/DVD Audio Input Connector

If you have installed a CD-ROM drive or DVD-ROM drive, you can connect the drive audio cable to the onboard sound system.

When you first start up your system, the BIOS should automatically detect your CD-ROM/DVD drive. If it doesn't, enter the Setup Utility and configure the CD-ROM/DVD drive that you have installed. On the mainboard, locate the 4-pin connector **CD2**.

CD2

Pin	Signal
1	CD IN L
2	GND
3	GND
4	CD IN R

SIR1: Serial infrared port

The mainboard supports a Serial Infrared (SIR1) data port. Infrared ports allow the wireless exchange of information between your computer and similarly equipped devices such as printers, laptops, Personal Digital Assistants (PDAs), and other computers.

Pin	Signal	Pin	Signal
1	NC	2	KEY
3	+5V	4	GND
5	IRTX	6	IRRX

Chapter 3

BIOS Setup Utility

Introduction

The BIOS Setup Utility records settings and information of your computer, such as date and time, the type of hardware installed, and various configuration settings. Your computer applies those information to initialize all the components when booting up and basic functions of coordination between system components.

If the Setup Utility configuration is incorrect, it may cause the system to malfunction. It can even stop your computer booting properly. If it happens, you can use the clear CMOS jumper to clear the CMOS memory which has stored the configuration information; or you can hold down the **Page Up** key while rebooting your computer. Holding down the **Page Up** key also clears the setup information.

You can run the setup utility and manually change the configuration. You might need to do this to configure some hardware installed in or connected to the mainboard, such as the CPU, system memory, disk drives, etc.

Running the Setup Utility

Every time you start your computer, a message appears on the screen before the operating system loading that prompts you to “Hit if you want to run SETUP”. Whenever you see this message, press the **Delete** key, and the Main menu page of the Setup Utility appears on your monitor.

AMIBIOS SIMPLE SETUP UTILITY – VERSION 1.21.12
(C) 2000 American Megatrends, Inc. All Rights Reserved

Standard CMOS Setup	Features Setup
Advanced Setup	CPU PnP Setup
Power Management Setup	Hardware Monitor
PCI / Plug and Play Setup	Change Password
Load Optimal Settings	Exit
Load Best Performance Settings	
Esc : Quit ↑ ↓ ← →: Select Item (Shift)F2 : Change Color F5 : Old Values F6 : Optimal values F7 : Best performance values F10 : Save&Exit	
Standards CMOS setup for changing time, date, hard disk type, etc.	

You can use cursor arrow keys to highlight anyone of options on the main menu page. Press **Enter** to select the highlighted option. Press the **Escape** key to leave the setup utility. Hold down the **Shift** key and press **F2** to cycle through the Setup Utility’s optional color schemes.

Some options on the main menu page lead to tables of items with installed values that you can use cursor arrow keys to highlight one item, and press **PgUp** and **PgDn** keys to cycle through alternative values of that item. The other options on the main menu page lead to dialog boxes requiring your answer Yes or No by hitting the **Y** or **N** keys.

If you have already changed the setup utility, press **F10** to save those changes and exit the utility. Press **F5** to reset the changes to the original values. Press **F6** to install the setup utility with a set of default values. Press **F7** to install the setup utility with a set of high-performance values.

Standard CMOS Setup Page

This page helps you set up basic information such as the date and time, the IDE devices, and the diskette drives.

AMIBIOS SETUP - STANDARD CMOS SETUP										
(C) 2000 American Megatrends, Inc. All Rights Reserved										
Date (mm/dd/yy) : Tue May 06, 2003										
Time (hh/mm/ss) : 16:14:12										
	Type	Size	Cyln	Head	WPcom	Sec	LBA Mode	Blk Mode	PIO Mode	32Bit Mode
Pri Master	: Auto									On
Pri Slave	: Auto									On
Sec Master	: Auto									On
Sec Slave	: Auto									On
Floppy Drive A : 1.44 MB 31/2										
Floppy Drive B : Not Installed										
Month : Jan - Dec							ESC : Exit			
Day : 01 - 31							↑↓ : Select Item			
Year : 1901 - 2099							PU/PD/+- : Modify			
							(Shift)F2 : Color			
							F3 : Detect All HDD			

Date & Time	Use these items to set up system date and time
IDE Pri Master	Use these items to configure devices connected to the Primary and Secondary IDE channels. To configure an IDE hard disk drive, choose <i>Auto</i> . If the <i>Auto</i> setting fails to find a hard disk drive, set it to <i>User</i> , and then fill in the hard disk characteristics (Size, Cyls, etc.) manually. If you have a CD-ROM drive, select the setting <i>CDROM</i> . If you have an ATAPI device with removable media (e.g. a ZIP drive or an LS-120), select <i>Floptical</i> .
Pri Slave	
Sec Master	
Sec Slave	
Floppy Drive A	Use these items to set up size and capacity of the floppy diskette drive(s) installed in the system.
Floppy Drive B	

Advanced Setup Page

This page sets up more advanced information about your system. Be very careful to this page. Any changes can affect the operation of your computer.

AMIBIOS SETUP – ADVANCED SETUP			
(C) 2000 American Megatrends, Inc. All Rights Reserved			
Quick Boot	Enabled	Auto detect DIMM/PCI Clk	Enabled
1 st Boot Device	IDE-0	CLK Gen Spread Spectrum	Disabled
2 nd Boot Device	Floppy	Hyper Threading Function	Disabled
3 rd Boot Device	CDROM		
Try Other Boot Devices	Yes		
S.M.A.R.T. for Hard Disks	Disabled		
BootUp Num-Lock	On		
Floppy Drive Swap	Disabled		
Floppy Drive Seek	Disabled		
Password Check	Setup		
Boot To OS/2	No		
L2 Cache	Enabled		
System BIOS Cacheable	Enabled		
DRAM Timing by SPD	Disables	ESC : Quit	↑↓←→ : Select Item
SDRAM Frequency	100MHz	F1 : Help	PU/PD/+/- : Modify
DRAM CAS# Latency	2.5	F5 : Old Values (Shift)	F2 : Color
DRAM Bank Interleave	Disabled	F6 : Load BIOS Defaults	
AGP Comp. Driving	Auto	F7 : Load Setup Defaults	
Manual AGP Comp. Driving	CB		
AGP Aperture Size	64MB		

Quick Boot	If you enable this item, the system starts up more quickly by elimination of some of the power on test routines.
1st Boot Device	Use these items to determine the device order the computer uses to look for an operating system to load at start-up time.
2nd Boot Device	
3rd Boot Device	
Try Other Boot Device	If you enable this item, the system will also search for other boot devices if it fails to find an operating system from the first two locations.

S.M.A.R.T. for Hard Disks	Enable this item if any IDE hard disks support the S.M.A.R.T. (Self-Monitoring, Analysis and Reporting Technology) feature.
BootUp Num-Lock	This item determines if the Num Lock key is active or inactive at system start-up time.
Floppy Drive Swap	If you have two diskette drives installed and you enable this item, drive A becomes drive B and drive B becomes drive A.
Floppy Drive Seek	If you enable this item, your system will check all floppy disk drives at start up. Disable this item unless you are using an old 360KB drive.
Password Check	If you have entered a password for the system, use this item to determine, if the password is required to enter the Setup Utility (<i>Setup</i>) or required both at start-up and to enter the Setup Utility (<i>Always</i>).
Boot to OS/2 > 64MB	Enable this item if you are booting the OS/2 operating system and you have more than 64MB of system memory installed.
L2 Cache	Leave these items enabled since all the processors that can be installed on this board have internal L2 cache memory.
System BIOS Cacheable	If you enable this item, a segment of the system BIOS will be copied to main memory for faster execution.
DRAM Timing By SPD	This item allows you to enable or disable the SDRAM timing defined by the Serial Presence Detect electrical.
SDRAM Frequency	This item determines frequency of SDRAM memory.

DRAM CAS# Latency	This item determines the operation of SDRAM memory CAS (column address strobe). It is recommended that you leave this item at the default value. The 2T setting requires faster memory that specifically supports this mode.
DRAM Bank Interleave	Enable this item to increase SDRAM memory speed. When enabled, separate memory banks are set for odd and even addresses and the next byte of memory can be accessed while the current byte is being refreshed.
AGP Comp. Driving	Use this item to signal driving current on AGP cards to auto or manual. Some AGP cards need stronger than normal driving current in order to operate. We recommend that you set this item to the default.
Manual AGP Comp. Driving	When AGP Driving is set to Manual, use this item to set the AGP current driving value.
AGP Aperture Size	This item defines an AGP for the graphics. Leave this item at the default value 64MB.
Auto detect DIMM/PCI Clock	When this item is enabled, BIOS will disable the clock signal of free DIMM/PCI slots.
CLK GEN Spread Spectrum	Use this item to set the system bus spread spectrum for the installed processor.
Hyper Threading Function	If your P4 CPU is not HT CPU, this item will be hidden. If your P4 CPU is HT CPU, BIOS will show this item. You can set "Disabled" or "Enabled" to control HT CPU support in O.S. Set "Enabled" to test HT CPU function.

Power Management Setup Page

This page sets up some parameters of system power management operation.

AMIBIOS SETUP – POWER MANAGEMENT SETUP (C) 2000 American Megatrends, Inc. All Rights Reserved		
ACPI Aware O/S	Yes	
Power Management	Enabled	
Suspend Time Out <Min.>	Disabled	
Hard Disk Time Out <Min.>	Disabled	
Resume On RTC Alarm	Disabled	
RTC Alarm Date	15	
RTC Alarm Hour	12	
RTC Alarm Minute	30	
RTC Alarm Second	30	ESC : Quit ↑↓←→ : Select Item
LAN/Ring Power On	Disabled	F1 : Help PU/PD/+/- : Modify
Keyboard Power On	Disabled	F5 : Old Values (Shift) F2 : Color
Wake-Up Key	Any key	F6 : Load BIOS Defaults
Wake-Up Password	N/A	F7 : Load Setup Defaults

ACPI Aware O/S This item supports ACPI (Advanced Configuration and Power management Interface). Use this item to enable or disable the ACPI feature.

Power Management Use this item to enable or disable a power management scheme. If you enable power management, you can use the items below to set the power management operation. Both APM and ACPI are supported.

Suspend Time Out This sets the timeout for Suspend mode in minutes. If the time selected passes without any system activity, the computer will enter power-saving Suspend mode.

Hard Disk Time Out This item sets up the timeout to power down the hard disk drive, if there is no hard disk activity after passing the preset period of time.

Resume On RTC Alarm / Date / Hour / Minute / Second	The system can be turned off with a software command. If you enable this item, the system can automatically resume at a fixed time based on the system's RTC (realtime clock). Use the items below this one to set the date and time of the wake-up alarm. You must use an ATX power supply in order to use this feature.
LAN/Ring Power On	The system can be turned off with a software command. If you enable this item, the system can automatically resume if there is an incoming call on the Modem. You must use an ATX power supply in order to use this feature.
Keyboard Power On Wake-Up Key Wake-Up Password	If you enable this item, system can automatically resume by pressing hot keys on the keyboard or typing in the password. You must enable the Keyboard Power On jumper and use an ATX power supply in order to use this feature.

PCI / Plug and Play Setup Page

This page sets up some parameters for devices installed on the PCI bus and those utilizing the system plug and play capability.

AMIBIOS SETUP - PCI / PLUG AND PLAY SETUP (C) 2000 American Megatrends, Inc. All Rights Reserved	
Plug and Play Aware O/S	Yes
Primary Graphics Adapter	AGP
Allocate IRQ to PCI VGA	Yes
PCI IDE BusMaster	Disabled
ESC : Quit ↑↓←→ : Select Item F1 : Help PU/PD/+/- : Modify F5 : Old Values (Shift)F2 : Color F6 : Load BIOS Defaults F7 : Load Setup Defaults	

Plug and Play Aware O/S	Enable this item if you are using an O/S that supports Plug and Play such as Windows 95 or 98.
Primary Graphics Adapter	This item indicates if the primary graphics adapter uses the PCI or the AGP bus. The default AGP setting still lets the onboard display work and allows the use of a second display card installed in an AGP slot.
Allocate IRQ to PCI VGA	If this item is enabled, an IRQ will be assigned to the PCI VGA graphics system. You set this value to No to free up an IRQ.
PCI IDE BusMaster	This item enables or disables the DMA under DOS mode. We recommend you to leave this item at the default value.

Load Optimal Settings

If you select this item and press **Enter** a dialog box appears. If you press **Y**, and then **Enter**, the Setup Utility loads a set of fail-safe default values. These default values are not very demanding and they should allow your system to function with most kinds of hardware and memory chips.

Note: It is highly recommended that users enter this option to load optimal values for accessing the best performance.

Load Best Performance Settings

If you select this item and press **Enter** a dialog box appears. If you press **Y**, and then **Enter**, the Setup Utility loads a set of best-performance default values. These default values are quite demanding and your system might not function properly if you are using slower memory chips or other low-performance components.

Features Setup Page

This page sets up some parameters for those peripheral devices connected to the system.

AMBIOS SETUP – FEATURES SETUP (C) 2000 American Megatrends, Inc. All Rights Reserved		
OnBoard FDC	Enabled	
OnBoard Serial PortA	3F8h/COM1	
OnBoard IR Port	Disabled	
OnBoard Parallel Port	378h	
Parallel Port Mode	SPP	
Parallel Port IRQ	7	
Parallel Port DMA	N/A	
OnBoard IDE	Both	ESC : Quit ↑↓←→ : Select Item
Audio Device	Enabled	
Modem Device	Auto	F1 : Help PU/PD/+/- : Modify
Ethernet Device	Enabled	F5 : Old Values (Shift)F2 : Color
USB Controller	Enabled	F6 : Load BIOS Defaults
USB Device Legacy Support	Disabled	F7 : Load Setup Defaults
ThumbDrive Support for DOS	Disabled	

OnBoard FDC	Use this item to enable or disable the onboard floppy disk drive interface.
OnBoard Serial PortA	Use this item to enable or disable the onboard COM1/2 serial port, and to assign a port address.
OnBoard IR Port	Use this item to enable or disable the onboard infrared port, and to assign a port address.
Parallel Port Mode	Use this item to set the parallel port mode. You can select SPP (Standard Parallel Port), ECP (Extended Capabilities Port), EPP (Enhanced Parallel Port), or ECP + EPP.
Parallel Port IRQ	Use this item to assign IRQ to the parallel port.
Parallel Port DMA	Use this item to assign a DMA channel to the parallel port.
OnBoard IDE	Use this item to enable or disable the onboard IDE channel.
Audio Device	This item enables or disables the AC'97 audio chip.

Modem Device	This item enables or disables the MC'97 modem chip.
Ethernet Device	This item enables or disables the onboard Ethernet LAN.
USB Controller	Use this item to select the USB ports or disabled.
USB Device Legacy Support	This item allows you to enable the USB device, if you have installed a USB device on the system board.
ThumbDrive Support For DOS	Enable this item to make a small portion of memory storage device for the USB ports.

CPU PnP Setup Page

This page helps you manually configure the mainboard for the CPU. The system will automatically detect the type of installed CPU and make the appropriate adjustments to the items on this page.

AMIBIOS SETUP - CPU PnP SETUP		
©2000 American Megatrends, Inc. All Rights Reserved		
CPU BRAND	INTEL	
CPU Type	Pentium 4	
CPU Ratio	8.0x	
CPU Frequency	100 MHz	
		ESC : Quit ↑↓←→ : Select Item F1 : Help PU/PD/+/- : Modify F5 : Old Values (Shift)F2 : Color F6 : Load Optimal values F7 : Load Best performance values

CPU BRAND/Type/Ratio/Frequency	These items show the brand, type, ratio and frequency of the CPU installed in your system.
---------------------------------------	--

Hardware Monitor Page

This page sets up some parameters for the hardware monitoring function of this mainboard.

AMBIOS SETUP - HARDWARE MONITOR (C) 2000 American Megatrends, Inc. All Rights Reserved		
*** System Hardware ***		
Vcore	1.632V	
Vcc 2.5V	2.496V	
Vcc 3.3V	3.392V	
Vcc 5V	4.919V	
+12V	12.096V	ESC : Quit ↑↓←→ : Select Item
-12V	-11.967V	F1 : Help PU/PD/+/- : Modify
SB5V	5.026V	F5 : Old Values (Shift)F2 : Color
VBAT	3.472V	F6 : Load BIOS Defaults
SYSTEM Fan Speed	0 RPM	F7 : Load Setup Defaults
CPU Fan Speed	1308 RPM	
Power Temperature	35°C/95°F	
SYSTEM Temperature	42°C/107°F	
CPU Temperature	52°C/125°F	

CPU / System Temperature	These items display CPU and system temperature measurement.
FAN & Voltage Measurements	These items indicate cooling fan speeds in RPM and the various system voltage measurements.

Change Password

If you highlight this item and press Enter, a dialog box appears that you can enter a Supervisor password. You can enter no more than six letters or numbers. Press Enter after you have typed in the password. There will be the second dialog box asking you to retype the password for confirmation. Press Enter after you have retyped it correctly. Then, the password is required for the access to the Setup Utility or for it at start-up, depending on the setting of the Password Check item in Advanced Setup.

Exit

Highlight this item and press Enter to save the changes that you have made in the Setup Utility configuration and exit the program. When the Save and Exit dialog box appears, press Y to save and exit, or press N to exit without saving.

Chapter 4

Software & Applications

Introduction

This chapter describes the contents of the support CD-ROM that comes with the mainboard package.

The support CD-ROM contains all useful software, necessary drivers and utility programs to properly run our products. More program information is available in a README file, located in the same directory as the software.

To run the support CD, simply insert the CD into your CD-ROM drive. An Auto Setup screen automatically pops out, and then you can go with the auto-installing or manual installation depending on your operating system.

If your operating system is Windows 98/ME/2000/XP, it will automatically install all the drivers and utilities for your mainboard; if Windows NT or manual installation, please follow the instructions described as the Installing under Windows NT or Manual Installation section.

Installing Support Software

1. Insert the support CD-ROM disc in the CD-ROM drive.
2. When you insert the CD-ROM disc in the system CD-ROM drive, the CD automatically displays an Auto Setup screen.
3. The screen displays three buttons of **Setup**, **Browse CD** and **Exit** on the right side, and three others **Setup**, **Application** and **ReadMe** at the bottom. Please see the following illustration.



The **Setup** button runs the software auto-installing program as explained in next section.

The **Browse CD** button is a standard Windows command that you can check the contents of the disc with the Windows 98 file browsing interface.

The **Exit** button closes the Auto Setup window. To run the program again, reinsert the CD-ROM disc in the drive; or click the CD-ROM driver from the Windows Explorer, and click the Setup icon.

The **Application** button brings up a software menu. It shows the bundled software that this mainboard supports.

The **ReadMe** brings you to the Install Path where you can find out path names of software driver.

Auto-Installing under Windows 98/ME/2000/XP

If you are under Windows 98/ME/2000/XP, please click the **Setup** button to run the software auto-installing program while the Auto Setup screen pops out after inserting the support CD-ROM:

1. The installation program loads and displays the following screen. Click the **Next** button.



2. Select the items that you want to setup by clicking on it (the default options are recommended). Click the **Next** button to proceed.



3. The support software will automatically install.

Once any of the installation procedures start, software is automatically installed in sequence. You need to follow the onscreen instructions, confirm commands and allow the computer to restart as few times as needed to complete installing whatever software you selected. When the process is finished, all the support software will be installed and start working.

Installing under Windows NT or Manual Installation

If you are under Windows NT, the auto-installing program doesn't work out; or you have to do the manual installation, please follow this procedure while the Auto Setup screen pops out after inserting the support CD-ROM:

1. Click the **ReadMe** to bring up a screen, and then click the Install Path at the bottom of the screen.
2. Find out your mainboard model name and click on it to obtain its correct driver directory.
3. Install each software in accordance with the corresponding driver path.

Bundled Software Installation

All bundled software available on the CD-ROM is for users' convenience. You can install bundled software as follows:

1. Click the **Application** button while the Auto Setup screen pops out after inserting the support CD-ROM.
2. A software menu appears. Click the software you want to install.
3. Follow onscreen instructions to install the software program step by step until finished.

Hyper Threading CPU

You must update BIOS to initiate BIOS Hyper Threading Function and use HT CPU function under WinXP Operating System; if not, please disable this option.

- ◆ When BIOS detects the HT CPU, it shows the “Hyper Threading Function (default Disabled)” option, which you must set Enabled if you want to test HT CPU function. If there is no HT CPU, this option is hidden and default Disabled.



- ◆ You must re-install WINXP to activate the HT CPU function.

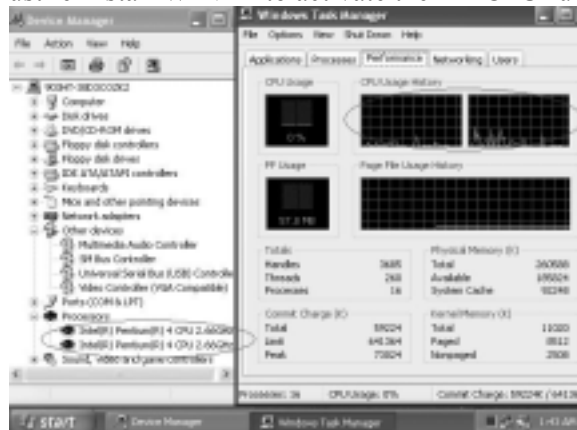

While you are in Windows Task Manager, please push down ctrl+Alt Del keys. A dual CPU appears in the CPU Usage History&Device Manager under WinXP.

Note: Hyper Threading Function only works under WINXP Operating System; therefore, disable it under other Operating System.
