

***USER'S MANUAL***  
***Of***  
***Intel 945GC Express Chipset***  
***&***  
***Intel FW82801GB ICH Chipset***  
***Based***  
***M/B For LGA 775 Core 2 Duo Processor***

***No. G03-945GCDMS-F***

***Rev: 4.0***

***Release date: July 2007***

**Trademark:**

\* Specifications and Information contained in this documentation are furnished for information use only, and are subject to change at any time without notice, and should not be construed as a commitment by manufacturer.

---

---

# TABLE OF CONTENT

---

---

<b>CHAPTER 1 INTRODUCTION OF INTEL 945GC MOTHERBOARD SERIES</b>	
1-1 FEATURES OF MOTHERBOARD .....	1
1-1.1 SPECIAL FEATURES OF MOTHERBOARD.....	2
1-2 SPECIFICATION.....	3
1-3 ITEM CHECKLIST .....	4
1-4 LAYOUT DIAGRAM & JUMPER SETTING .....	4
<b>CHAPTER 2 HARDWARE INSTALLATION</b>	
2-1 INSTALL LGA 775 SUPPORTED INTEL PROCESSOR.....	5
2-2 INSTALL MEMORY .....	6
2-3 EXPANSION CARDS .....	7
<b>CHAPTER 3 CONNCTORS, HEADERS &amp; JUMPERS SETTING</b>	
3-1 CONNECTORS .....	8
3-2 HEADERS.....	10
<b>CHAPTER 4 USEFUL HELP</b>	
4-1 HOW TO UPDATE BIOS.....	12
4-2 TROUBLE SHOOTING .....	12

## Environmental Protection Announcement

Do not dispose this electronic device into the trash while discarding. To minimize pollution and ensure environment protection of mother earth, please recycle.



---

---

# Chapter 1

## Introduction of Intel 945GC Motherboard Series

### 1-1 Features of motherboard

The Intel 945GC chipset motherboard series are based on the latest Intel 945GC Express Chipset and Intel FW82801GB ICH Chipset technology which supports the innovative 65nm and 90nm Dual-Core Intel® Pentium® D Processor 8 and 9 Series, Intel® Pentium® D Processor, and Intel® Core 2 Duo® (Code Name: Conroe) Processor with Intel® Hyper-Threading Technology. The motherboard is optimized to deliver innovative features and professional desktop platform solution with the advantages of the new generation dual core Intel® Core 2 Duo® Processor for those who demand the best experience of personal computing. Through the high bandwidth of dual channel DDR2 400/DDR2 533MHz/DDR2 667MHz system memories which are expandable to 2.0GB and the next generation PCI Express interface for the latest graphics cards from both NVIDIA & ATI.

The Intel 945GC chipset motherboard series for Intel® Core 2 Duo® Processor are absolutely the cost-effective solution for game enthusiasts and applications, and it also meets the demanding usage of computing of gaming, multimedia entertainment and business applications. Moreover, the Intel 945GC express chipset incorporates Intel Graphics Media Accelerator 950 which support the Microsoft\* DirectX\* 9, Vertex Shader 3.0 and Transform and Lighting provides incredible visual quality, faster graphics performance and flexible display options without the need for a separate graphics card.

The motherboards implement Intel 945GC Express Chipset which supports Front Side Bus [1066MHz / 800MHz](#) of data transferring and offers with 200MHz/ 266MHz/ 333MHz memory clock frequency for Dual channel DDR2 400/DDR2 533/DDR2 667 MHz memory DIMMs to double the performance of memory access. The motherboard is embedded with ICH7 chipset of providing one parallel Ultra ATA 100 interface for two IDE drives and four serial ATA2 interface of 3.0Gb / s data transfer rate for four serial ATA devices.

The 945GC motherboard series offer one PCI-Express x16 graphics slot of 4Gbyte/sec data transfer rate at each relative direction which gets 3.5 times of bandwidth more than AGP 8X and it's up to a peak concurrent bandwidth of 8Gbyte/sec at full speed to guarantee the ultimate GPU computing performance. Two 32-bit PCI slots guarantee the rich connectivity for the I/O of peripherals. The motherboards are designed of tackling the profuse multimedia requirements nowadays.

The motherboards provide optional 10 / 100 or 10/ 100/1000 Ethernet compatible LAN function by using the Realtek RTL8100C 10/100 LAN NIC or Realtek RTL8110SC 10/100/1000 LAN NIC which supports 10M / 100M bps or 10M 100M /1000M bps data transfer rate. And the embedded Realtek ALC880 or ALC883 chipset fully compatible with Sound Blaster Pro standards with providing optional Azalia 8-channel Audio CODEC or 6-channel AC' 97 CODEC offers you with the home cinema quality and satisfying software compatibility.

---

---

Embedded USB controller as well as capability of expanding to 8 of USB2.0 functional ports delivering 480Mb/s of rich connectivity, these motherboards meet the demands of future USB peripherals which are also equipped with hardware monitor function on system to monitor and protect your system and maintain your non-stop business computing.

Some special features---**CPU Thermal Throttling/ CPU Vcore 7-shift / CPU Smart Fan/** in this motherboard are designed for power user to use the over-clocking function in more flexible ways. But please be caution that the over-clocking maybe causes the fails in system reliabilities. This motherboard provides the guaranteed performance and meets the demands of the next generation computing. But if you insist to gain more system performance with variety possibilities of the components you choose, please be careful and make sure to read the detailed descriptions of these value added product features, please get them in the coming section.

## **1-1.1 Special Features of Motherboard**

### **CPU Thermal Throttling Technology**---(The CPU Overheat Protection Technology)

To prevent the increasing heat from damage of CPU or accidental shutdown while at high workload, the CPU Thermal Throttling Technology will force CPU to enter partially idle mode from 87.5% to 12.5% according to preset CPU operating temperature in BIOS (from 40°C to 90°C). When the system senses the CPU operating temperature reaching the preset value, the CPU operating bandwidth will be decreased to the preset idle percentage to cool down the processor. When at throttling mode the beeper sound can be optionally selected to indicate it is in working.

### **CPU Smart Fan**---( The Noise Management System ( Only support 4-pin CPU cooler) )

It's never been a good idea to gain the performance of your system by sacrificing its acoustics. CPU Smart Fan Noise Management System is the answer to control the noise level needed for now-a-day's high performance computing system. The system will automatically increase the fan speed when CPU operating loading is high, after the CPU is in normal operating condition, the system will low down the fan speed for the silent operating environment. The system can provide the much longer life cycle for both CPU and the system fans for game use and business requirements.

### **CPU Vcore 7-Shift**--- (Shift to Higher Performance)

The CPU voltage can be adjusted up by 7 steps for the precisely over-clocking of extra demanding computing performance.

## 1-2 Specification

Spec	Description
<b>Design</b>	* Micro ATX form factor 4 layers PCB size: 24.4*21.0cm
<b>Chipset</b>	* Intel 945GC Memory Controller Hub (MCH) Chipset * Intel 82801GB I/O Controller Hub (ICH7) Chipset
<b>CPU Socket (LGA775 )</b>	* Support Intel Pentium 4, Celeron D, Pentium D, and Core 2 Duo 775-Land LGA Package utilizes Flip-Chip Land Grid Array (FCLGA) package processor * Support FSB Frequency 1066/800MHz
<b>Memory Socket</b>	* 240-pin DDR2 RAM module socket x 2 * Support Dual channel DDR2 400/DDR2 533/DDR2 667 MHz RAM Module and which is expandable to 2.0GB.
<b>Expansion Slots</b>	* PCI-Express x16 slot 1pcs delivers up to 8 GB/s of concurrent bandwidth. * 32-bit PCI slot x 2pcs at 133MHz
<b>Integrate IDE and Serial ATA2</b>	* One PCI IDE controller that supports PCI Bus Mastering, ATA PIO/DMA and the ULTRA DMA 33/66/100 functions that deliver the data transfer rate up to 100 MB/s; four Serial ATA2 ports provide 3.0 Gb /sec data transfer rate.
<b>Integrated VGA</b>	* Integrated Graphic Media Accelerator 950 * 256-bit graphics core running at 400MHz * 1.6 GPixels/sec and 1.6 GTexels/sec fill rate * Up to 224 MB maximum video memory * Up to 4 pixels per clock rendering
<b>Optional LAN</b>	* Integrated Realtek RTL8110SC PCI 10 / 100 / 1000 LAN / RTL8100C PCI 10/100 LAN chip. * Support Fast Ethernet LAN function of providing 10Mb / 100Mb 1000 Mb/s or 10Mb / 100Mb/s data transfer rate
<b>6CH-Audio (Option)</b>	* Realtek 6-channel ALC ALC880 or ALC883 AC'97 Audio Codec onboard * 6-channel AC'97 Audio CODEC onboard * Audio driver and utility included
<b>HD 8-CH Audio (Option)</b>	* Realtek ALC880 or ALC883 Azalia 8-channel Audio Codec integrated * Support 8-channel 3D surround & Positioning Audio * Audio driver and utility included
<b>BIOS</b>	* Award 4MB Flash ROM
<b>Multi I/O</b>	* PS/2 keyboard and PS/2 mouse connectors * Floppy disk drive connector x1 * Parallel headerx1 / Serial port x1 (Optional) * D-Sub 15-pin VGA Conn. * Optional DVI port * USB 2.0 connector x 4, headers x4 (connecting cable option) * 8-channel Audio connector (Line-in, Line-out, MIC/ 8CH Audio)

### 1-3 Item Checklist

- ☑ Intel 945GC Platform Processor Chipset based motherboard
- ☑ Cable for IDE
- ☑ CD for motherboard utilities
- ☑ Cable for Serial ATA Port
- ☑ Intel 945GC Platform Processor Chipset motherboard User's Manual

### 1-4 Layout Diagram & Jumper Setting

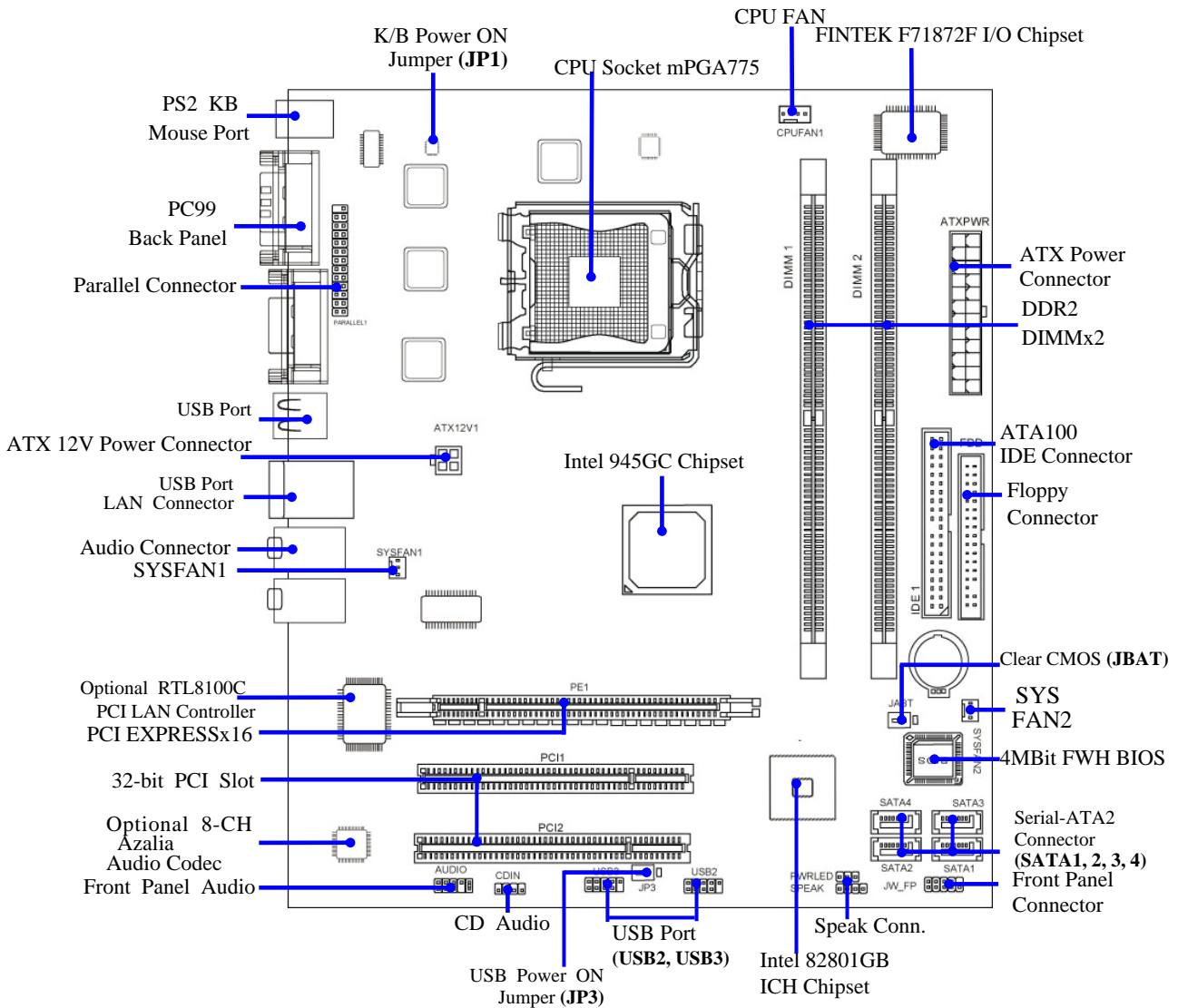

---

---

## Chapter 2

### Hardware Installation

#### 2-1 Install LGA 775 Supported Intel Processor

This motherboard provides a 775-pin surface mount, LGA775 Land Grid Array socket, referred to as the LGA775 socket supports Intel Pentium 4 processor in the 775 Pin package utilizes Flip-Chip Land Grid Array (FC-LGA) package technology.

The CPU that comes with the motherboard should have a cooling FAN attached to prevent overheating. If this is not the case, then purchase a correct cooling FAN before you turn on your system.

**WARNING!** Be sure that there is sufficient air circulation across the processor's heatsink and CPU cooling FAN is working correctly, otherwise it may cause the processor and motherboard overheat and damage, you may install an auxiliary cooling FAN, if necessary.

To install a CPU, first turn off your system and remove its cover. Locate the LGA775 socket and open it by first pulling the level sideways away from the socket then upward to a 90-degree angle. Insert the CPU with the correct orientation as shown below. The notched corner should point toward the end of the level. Because the CPU has a corner pin for two of the four corners, the CPU will only fit in the orientation as shown.

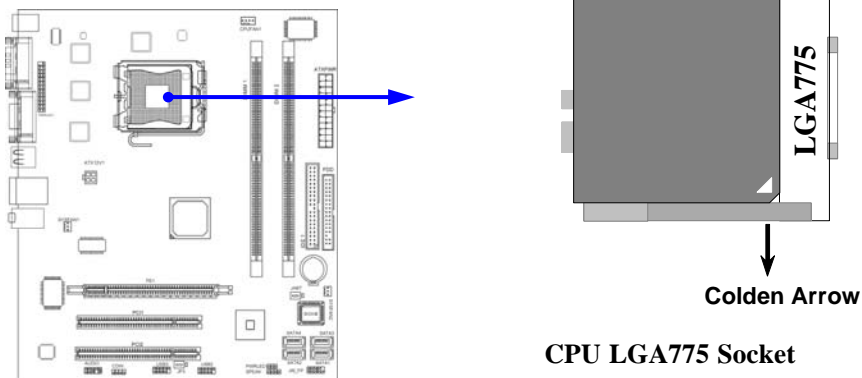

## 2-2 Install Memory

This motherboard provides two 240-pin DDR2 DUAL INLINE MEMORY MODULES (DIMM) socket for DDR2 memory expansion available from minimum memory volume of 128MB to maximum memory volume of 2.0GB DDR2 SDRAM.

### Valid Memory Configurations

Bank	240-Pin DIMM	PCS	Total Memory
Bank 0, 1 (DIMM1)	DDR2 400/ 533 DDR DRAM Module	X1	128MB~1.0GB
Bank 2, 3 (DIMM2)	DDR2 400/ 533 DDR DRAM Module	X1	128MB~1.0GB
Total	Memory (Max.2.0GB)	2	128MB~2.0GB

### Recommend DIMM Module Combination

1. **One DIMM Module** ---Plug in DIMM1
2. **Two DIMM Modules**---Plug in DIMM1 and DIMM2 for Dual channel function

### For Dual channel Limited!

3. Dual channel function only supports when 2 DIMM Modules plug in either both DIMM1 & DIMM2
4. DIMM1 & DIMM2 must be the same type, same size, same frequency for dual channel function.

Install DDR2 SDRAM modules to your motherboard is not difficult, you can refer to figure below to see how to install a 240-Pin DDR2 400/DDR2 533 SDRAM module.

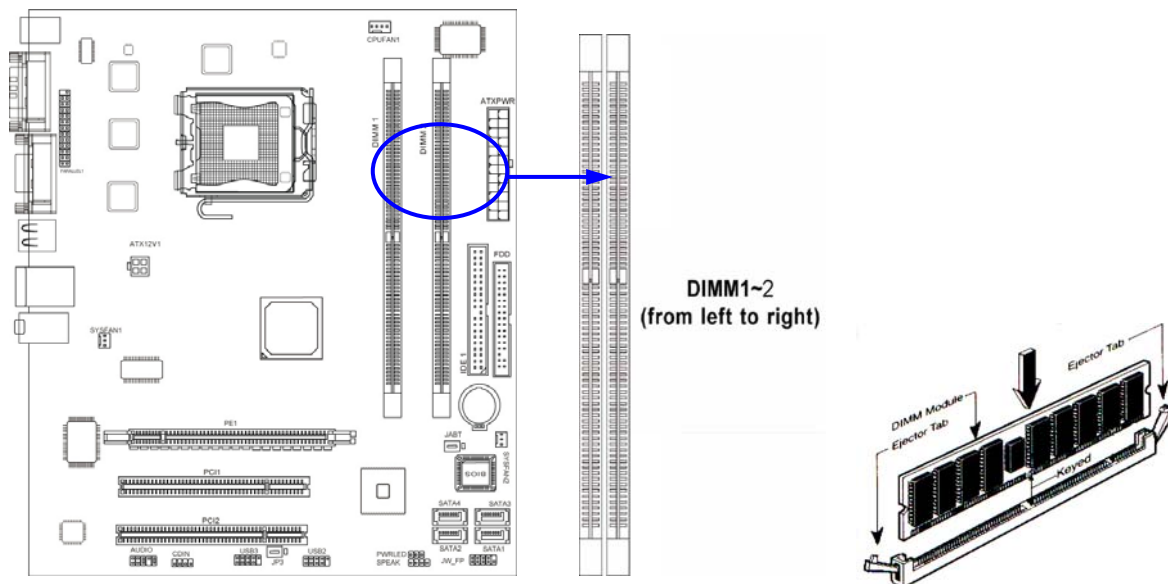

**NOTE!** When you install DIMM module fully into the DIMM socket the eject tab should be locked into the DIMM module very firmly and fit into its indentation on both sides.



---

---

## 2-3 Expansion Cards

The 945GC motherboard series offer one PCI-Express x16 graphics slot of 4Gbyte/sec data transfer rate at each relative direction which gets 3.5 times of bandwidth more than AGP 8X and it's up to a peak concurrent bandwidth of 8Gbyte/sec at full speed to guarantee the ultimate GPU computing performance. Two 32-bit PCI slots guarantee the rich connectivity for the I/O of peripherals. The motherboards are designed of tackling the profuse multimedia requirements nowadays..

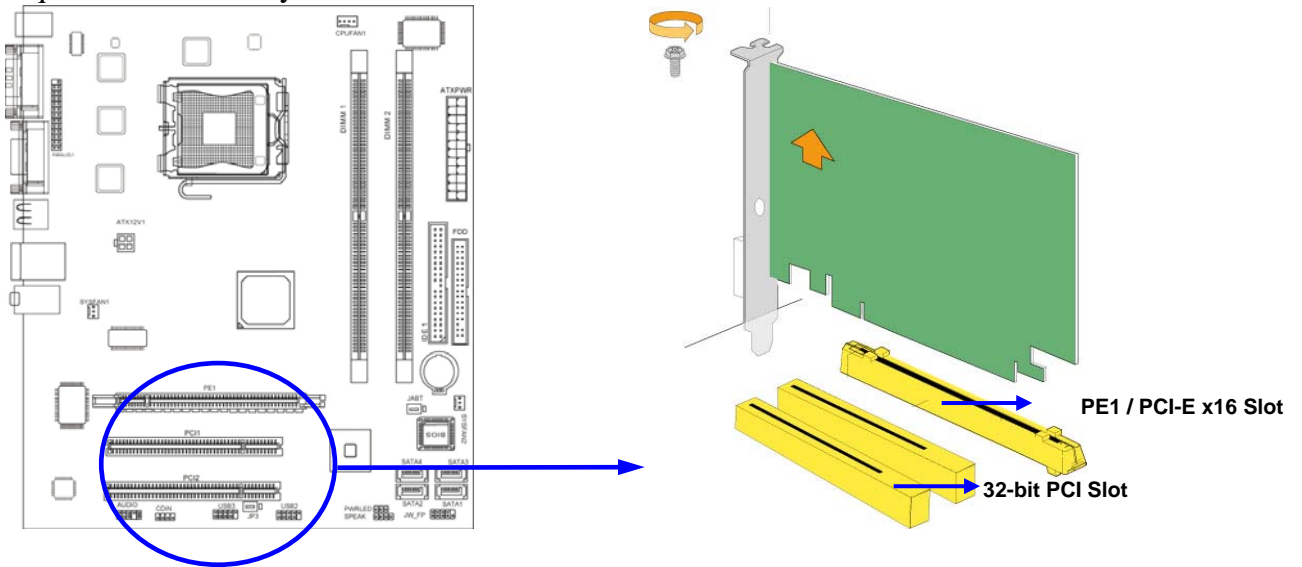

# Chapter 3

## Connectors, Headers & Jumpers Setting

### 3-1 Connectors

**(1) Power Connector (24-pin block) : ATXPWR1**

ATX Power Supply connector:  
 This is a new defined 24-pins connector that usually comes with ATX case. The ATX Power Supply allows using soft power on momentary switch that connect from the front panel switch to 2-pins Power On jumper pole on the motherboard. When the power switch on the back of the ATX power supply turned on, the full power will not come into the system board until the front panel switch is momentarily pressed. Press this switch again will turn off the power to the system board.

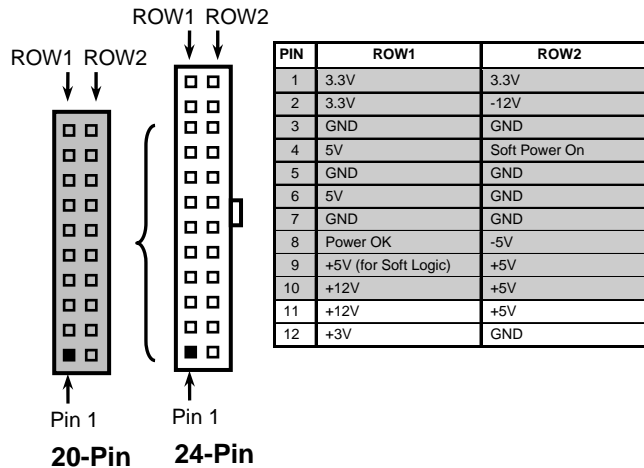

- \*\* We recommend that you use an ATX 12V Specification 2.0-compliant power supply unit (PSU) with a minimum of 350W power rating. This type has 24-pin and 4-pin power plugs.
- \*\* If you intend to use a PSU with 20-pin and 4-pin power plugs, make sure that the 20-pin power plug can provide at least 15A on +12V and the power supply unit has a minimum power rating of 350W. The system may become unstable or may not boot up if the power is inadequate.

**(2) ATX 12V Power Connector (4-pin block) : ATX12V**

This is a new defined 4-pins connector that usually comes with ATX Power Supply. The ATX Power Supply which fully supports AM2 processor must including this connector for support extra 12V voltage to maintain system power consumption. Without this connector might cause system unstable because the power supply can not provide sufficient current for system.



**(3) PS/2 Mouse & PS/2 Keyboard Connector: KB1**

The connectors are for PS/2 keyboard and PS/2 Mouse.

**(4) USB Port connector: CN3**

The connectors are 4-pin connectors that connect USB devices to the system board.

**(5) LAN Port connector: UL1**

This connector is standard RJ45 connector for Network

The USBLAN1 support 10M/100M bps or 10M/100M/1000M bps data transfer rate

**(6) Audio Line-In, Lin-Out, MIC, Surrback, Surround, GEN/LEF Connector, SURROUND1 (Option)** This Connector are 6 phone Jack for LINE-OUT, LINE-IN, MIC, Surrback, Surround, GEN/LEF

- Line-out : (GREEN)** Audio output to speaker
- Line-in : (BLUE)** Audio input to sound chip
- MIC : (PINK)** Microphone Connector

**Surround : (ORANGE)** Audio output to speaker-Rear speaker out  
**CEN / LFE : (BLACKNESS)** Audio output to speaker-Center/Subwoofer speaker out  
**Side Surround: (GRAY)** Audio output to speaker-Side speaker out

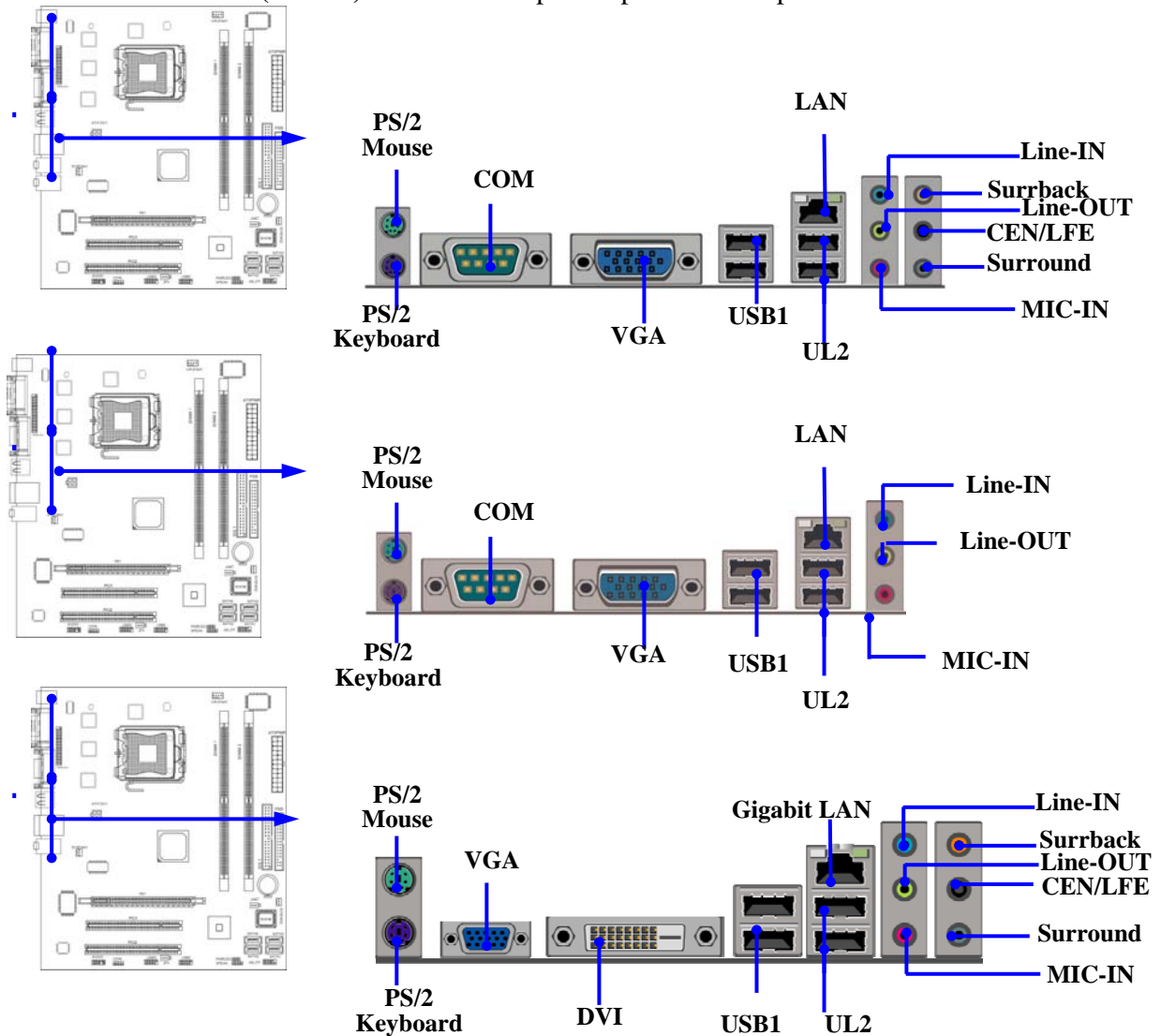

**(7) Floppy drive Connector (34-pin block): FDD1**

This connector supports the provided floppy drive ribbon cable. After connecting the single plug end to motherboard, connect the two plugs at other end to the floppy drives.

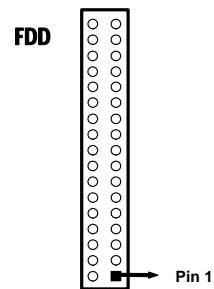

Floppy Drive Connector

**(8) DVI: Digital Visual Interface (Optional)**

This interface standard designed to maximize the visual quality of digital display devices such as flat panel LCD computer displays and digital projectors.

**(9) Primary IDE Connector (40-pin block): IDE1**

This connector connects to the next set of Master and Slave hard disks. Follow the same procedure described for the primary IDE connector. You may also configure two hard disks to be both Masters using one ribbon cable on the primary IDE connector and another ribbon cable on the secondary IDE connector.

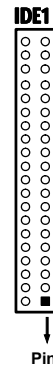

Primary IDE Connector

- Two hard disks can be connected to each connector. The first HDD is referred to as the “Master” and the second HDD is referred to as the “Slave”.
- For performance issues, we strongly suggest you don’t install a CD-ROM or DVD-ROM drive on the same IDE channel as a hard disk. Otherwise, the system performance on this channel may drop.

**(10) Serial-ATA Port connector:**

**SATA1 / SATA2 / SATA3/ SATA4**

These connectors support the provided Serial ATA and Serial ATA2 IDE hard disk cable to connecting the motherboard and serial ATA hard disk.

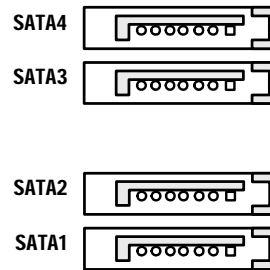

Serial-ATA1 & 2 Compatible Connectors

**(11) Serial COM Port: COM1 (Optional)**

COM1 is the 9-pin connector. The On-board serial port can be disabled through BIOS SETUP.

**(12) VGA Connector (15-pin D-Sub) Connector: VGA1**

VGA is the 15-pin D-Subminiature female connector for display monitor.

**3-2 Headers**

**(1) Line-Out/MIC Header for Front Panel (9-pin): AUDIO1**

This header connect to Front Panel Line-out, MIC connector with cable. Without install the cable, this header default setting is 5-6 short, 9-10 short. When you install the cable you have take off these jumpers.

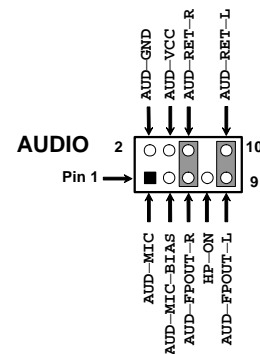

Line-Out, MIC Headers

**(2) USB Port Headers (9-pin) :**

**USB2 / USB3**

These headers are used for connecting the additional USB port plug. By attaching an option USB cable, your can be provided with two additional USB plugs affixed to the back panel.

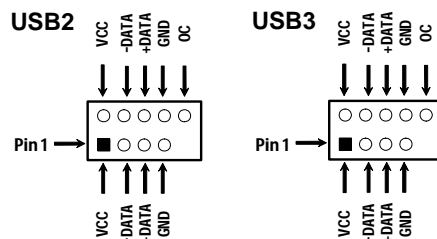

USB Port Headers

**(3) Speaker connector: SPEAK1**

This 4-pin connector connects to the case-mounted speaker. See the figure below.

**(4) Power LED: PWR LED1**

The Power LED is light on while the system power is on. Connect the Power LED from the system case to this pin.

**(5) IDE Activity LED: HD LED**

This connector connects to the hard disk activity indicator light on the case.

**(6) Reset switch lead: RESET**

This 2-pin connector connects to the case-mounted reset switch for rebooting your computer without having to turn off your power switch. This is a preferred method of rebooting in order to prolong the life of the system's power supply. See the figure below.

**(7) Power switch: PWR BTN**

This 2-pin connector connects to the case-mounted power switch to power ON/OFF the system.

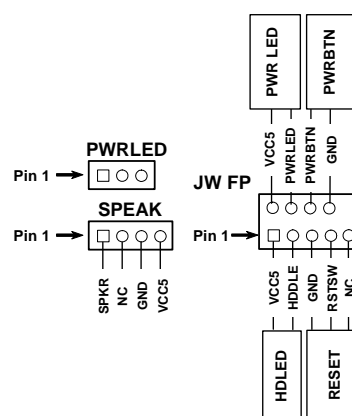

System Case Connections

**(8) FAN Power Headers: SYSFAN1, SYSFAN2 (3-pin), CPUFAN (4-pin)**

These connectors support cooling fans of 350mA (4.2 Watts) or less, depending on the fan manufacturer, the wire and plug may be different. The red wire should be positive, while the black should be ground. Connect the fan's plug to the board taking into consideration the polarity of connector.

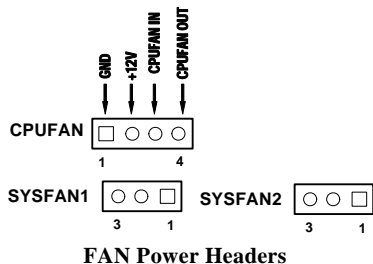

FAN Power Headers

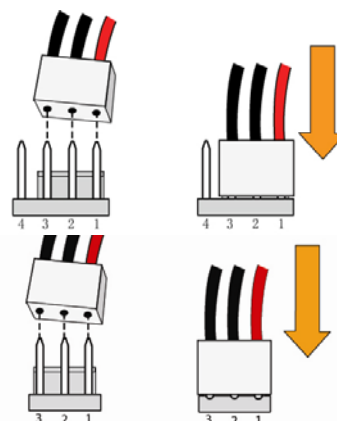

**(9) CD Audio-In Headers (4-pin) : CDIN**

CDIN are the connectors for CD-Audio Input signal. Please connect it to CD-ROM CD-Audio output connector.

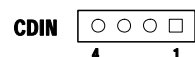

CD Audio-In Headers

**(10) Parallel Port header (25-pin): PARALLEL1**

The On-board Parallel Port can be disabled through the BIOS SETUP.

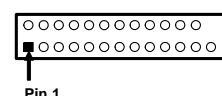

PARALLEL Connector

---

---

# Chapter 4

## USEFUL HELP

### 4-1 HOW TO UPDATE BIOS

Before updating the BIOS, users have to “Disable” the “Flash Part Write Protect” selection in “Miscellaneous Control” of BIOS SETUP. Otherwise the system will not allow you to upgrade BIOS by Award Flash Utility.

**STEP 1.** Prepare a boot disc. (you may make one by click START click RUN type SYS A:click OK)

**STEP 2.** Copy utility program to your boot disc. You may copy from DRIVER CD  
X:\FLASH\AWDFLASH.EXE or download from our web site.

**STEP 3.** Download and make a copy of the latest BIOS for 945GC PPC motherboard series from the web site to your boot disc.

**STEP 4.** Insert your boot disc into A:,  
start the computer, type “Awdflash A:\ Intel 945GC .BIN /SN/PY/CC/R”  
Intel 945GC xxx.BIN is the file name of latest BIOS it can be Intel 945GCX.BIN or Intel 945GCY.BIN

SN means don't save existing BIOS data

PY means renew existing BIOS data

CC means clear existing CMOS data

R means restart computer

**STEP 5.** Press ENTER to update and flash the BIOS, then the system will restart automatically.

### 4-2 Trouble Shooting

Problem	Solution
No power to the system to the all power light don't illuminate, fan inside power supply doesn't turn on.	1. Make sure power cable is security plugged in. 2. Replace cable. 3. Contact technical support.
System inoperative. Keyboard lights are on , power indicator lights are lit, and hard drive is spinning.	Using ever pressure on both ends of the DIMM , press down firmly until the module snaps into places.
System doesn't boot from hard disk drive, can be booted from optical drive.	1. Check cable running from disk to disk controller board. .Make sure both ends are securely plugged in, check the drive type in the standard CMOS setup. 2. Backing up the hard drive is extremely important .All hard disks are capable of breaking down at any time.
System only boots from optical drive .Hard disk can be read and applications can be used but booting from hard disk is impossible.	1. Back up date and applications files. 2. Reformat the hard drive. Reinstall applications and date using backup disks.
Screen message says “Invalid Configuration” or “CMOS Failure”	Review system 's equipment .Make sure correct information on is in setup.
Can not boot system after installing second hard drive.	1. Set master /slave jumpers correctly. 2. Run SETUP program and select correct drive types. Call the drive manufacture for compatibility with other drives.