



CERTIFICATE

The TÜV CERT Certification Body
for QM Systems of RWTÜV Systems GmbH

hereby certifies in accordance with TÜV CERT
procedure that

ELITEGROUP COMPUTER SYSTEMS CO., LTD.
ECS MANUFACTURING (SHENZHEN) CO., LTD.
ELITE TECHNOLOGY (SHENZHEN) CO., LTD.

2F, No. 240, Sec. 1, Nei Hu Road, Taipei, Taiwan 114
No. 22, Alley 38, Lane 91, Sec. 1, Nei Hu Road, Taipei, Taiwan 114
No. 20 & No. 26, Free Trade Zone, Shatoujiao, Shenzhen City, Guangdong Province, China

has established and applies a quality system for

**Design, Manufacturing and Sales of Mainboards,
Personal Computers, Notebooks and Peripheral Cards**

An audit was performed, Report No. 2.5-1585/2000

Proof has been furnished that the requirements according to
ISO 9001 : 2000 / EN ISO 9001 : 2000 / JIS Q 9001 : 2000 / ANSI/ASQC Q9001 : 2000

are fulfilled. The certificate is valid until 27 January 2007

Certificate Registration No. 04100 2000 1325

The company has been certified since 2000



Essen, 04.03.2004



The TÜV CERT Certification Body for QM Systems
of RWTÜV Systems GmbH



ISO14001 CERTIFICATE

Certificate NO.: 05-2001-065

We hereby certify that
ECS Manufacturing(Shenzhen) Co.,Ltd
by reason of its
Environmental Management System
has been awarded this certificate for
compliance with the standard
ISO14001:1996
The Environmental Management System
applies in the following area:

The manufacture of Mother Board and Peripheral Card and interrelated
management activities of ECS Manufacturing(Shenzhen) Co.,Ltd,
which is located in No.20,Free Trade Zone,Shatuojiao,Shenzhen, P. R.China.

Date of issue: 30th Dec 2001

Date of expiry: 29th Dec 2004

Signed by:



SHENZHEN ENVIRONMENTAL MANAGEMENT SYSTEM CERTIFICATION CENTER

This publication, including photographs, illustrations and software, is under the protection of international copyright laws, with all rights reserved. Neither this User's Guide, nor any of the material contained herein, may be reproduced without the express written consent of the manufacturer. The information in this document is subject to change without notice. The manufacturer makes no representations or warranties with respect to the contents hereof and specifically disclaims any implied warranties of merchantability or fitness for any particular purpose. Further, the manufacturer reserves the right to revise this publication and to make changes from time to time in the content hereof without obligation of the manufacturer to notify any person of such revision or changes.

Trademarks

IBM, VGA, and PS/2 are registered trademarks of International Business Machines.

AMD, Duron and Athlon are registered trademarks of Advanced Micro Devices Inc.

Microsoft, MS-DOS and Windows 98/ME/NT/2000/XP are registered trademarks of Microsoft Corporation.

AMI is a registered trademark of American Megatrends Inc.

Other names used in this publication may be trademarks and are acknowledged.

Static Electricity Precautions

1. Don't take this motherboard and components out of their original static-proof package until you are ready to install them.
2. While installing, please wear a grounded wrist strap if possible. If you don't have a wrist strap, discharge static electricity by touching the bare metal of the system chassis.
3. Carefully hold this motherboard by its edges. Do not touch those components unless it is absolutely necessary. Put this motherboard on the top of static-protection package with component side facing up while installing.

Pre-Installation Inspection

1. Inspect this motherboard whether there are any damages to components and connectors on the board.
2. If you suspect this motherboard has been damaged, do not connect power to the system. Contact your motherboard vendor about those damages.

**Copyright © 2005
All Rights Reserved
M863AG/G Series, V5.1B
January 2005**

Table of Contents

Trademark i
Static Electricity Precautions i
Pre-Installation Inspection i
Features & Checklist Translations iv

Chapter 1: Introduction 1
Key Features 1
Package Contents 4

Chapter 2: Motherboard Installation 5
Motherboard Components 6
I/O Ports 7
Installing the Processor 7
Installing Memory Modules 9
Jumper Settings 10
Install the Motherboard 11
Connecting Optional Devices 12
Install Other Devices 14
Expansion Slots 16

Chapter 3: BIOS Setup Utility 17
Introduction 17
Running the Setup Utility 17
Standard CMOS Setup Page 18
Features Setup Page 20
Power Management Setup Page 21
PCI/Plug and Play Setup Page 22
BIOS Security Features Setup Page 23
CPU PnP Setup Page 24
Hardware Monitor Page 24
Load Optimal Defaults 25
Save Changes and Exit 25
Discard Changes and Exit 25

Chapter 4: Software & Applications 26
Introduction 26
Installing Support Software 26
Bundled Software Installation 28

Notice:

1. Owing to Microsoft's certifying schedule is various to every supplier, we might have some drivers not certified yet by Microsoft. Therefore, it might happen under Windows XP that a dialogue box (shown as below) pops out warning you this software has not passed Windows Logo testing to verify its compatibility with Windows XP. Please rest assured that our RD department has already tested and verified these drivers. Just click the "Continue Anyway" button and go ahead the installation.

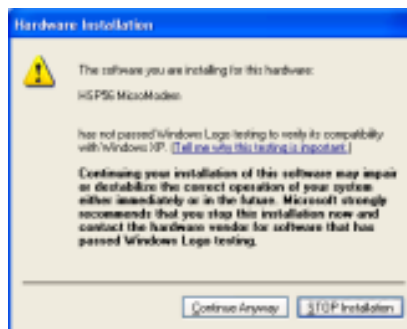

2. USB 2.0 Driver Limitations:

- 2-1. The USB 2.0 driver only supports Windows XP and Windows 2000.
- 2-2. If you connect a USB 2.0 hub to the root hub, plugging USB devices into this hub, the system might not successfully execute certain USB devices' connection because it could not recognize these devices.

Currently, we are working on such limitations' solution. As soon as the solution is done, the updated USB drive will be released to our website: www.pcchips.com for your downloading.

Guide de l'utilisateur de la carte mère

Traduction des Caractéristiques & Liste de contrôle

Liste de contrôle

Le coffret de votre carte mère contient les éléments suivants:

- La carte mère
- Le Manuel utilisateur
- Un câble plat pour lecteur de disquette (optionnel)
- Une câble plat pour lecteur IDE
- CD de support de logiciels

Caractéristiques

Prise en charge du Processeur Socket-A

- Prend en charge les processeurs AMD **Athlon XP/Sempron**
- Supporte un Bus Avant allant jusqu'à **400 MHz** (M863AG)/333 MHz (M863G)

Chipset

Ce chipset comporte **SiS741/SiS741GX Northbridge** et **SiS964L Southbridge** conformément à une architecture novatrice et dimensionnable avec une fiabilité et des performances prouvées. Cette série de carte mères a deux modèles M863AG et M863G :

Modèle	Northbridge	Southbridge	Fonction
M863AG	SiS 741	964L	CPU FSB: 400MHz DDR400
M863G	SiS 741GX	964L	CPU FSB: 333MHz DDR333/266

- Supporte les CPU AMD **Athlon XP/Sempron** avec FSB jusqu'à **400(SiS741 NB seulement) /333MHz**, et Temporisation Hôte vers DRAM Synchrone/Quasi-synchrone
- Supporte le **400(SiS741 NB seulement)/333/266 SDRAM DDR** et contrôleur de mémoire unifiée de haute performance optimisant l'utilisation du bus DRAM
- Supporte l'Interface AGP 8X/4X avec Fast Write Transaction
- Moteur 3D 256 bits de haute performance et Moteur d'installation en triangle VLIW au format de virgule flottante en 32 bits intégré
- Le lien Multiprocessus E/S intégré assure l'accès simultané de transfert de données en amont/aval avec une bande passante de 1.2Go/s.
- Conforme aux spécifications PCI 2.2
- Maîtrise de lien Multiprocessus E/S intégré
- Maîtrise de Liaison d'E/S Multiprocessus avec transaction Simultanée de Lecture/Ecriture

Support de Mémoire

- Deux sockets DIMM de 2.5V 184 broches pour module mémoire DDR SDRAM
- Supporte le bus mémoire DDR **400 (SiS741 NB seulement)/333/266**
- La mémoire maximum installée est 2Go

Logements d'Extension

- Deux logements PCI 32 bits
- Un logement **8X** AGP
- Un logement CNR

Canaux IDE internes

- Deux Connecteurs IDE

Guide de l'utilisateur de la carte mère

- Prend en Charge les modes PIO (Entrée/Sortie Programmable) et DMA (Accès Direct à la Mémoire)
- Supporte maîtrise de bus Ultra DMA IDE avec vitesse de transfert de **133/100/66 Mo/sec**

AC'97 Audio Codec

- 6- canaux et conforme aux Spéc. Intel AC'97 (REV. 2.3), respectant les exigences de Microsoft PC2001
- Gestion d'alimentation avancée et capacités d'économie d'énergie.
- Fonction de ligne d'entrée stéréo partagée avec la sortie Contour.
- Entrée de CD Audio analogique pseudo différentielle de haute qualité.
- Support Sortie S/PDIF : Sortie 96/ 48 kHz avec 24/20/16 bits
- Technologie logicielle complémentaire de valeur. Supporte la plupart des standards de l'industrie de son 3D PC et support de fonction de karaoké unique qui comprend l'écho microphone, décalage de touche, et annulation vocale.

Ports E/S Internes

- Deux ports PS/2 pour souris et clavier
- Un port série
- Un port parallèle
- Un port VGA
- Quatre ports USB 2.0 de panneau arrière
- Un port LAN (optionnel)
- Prises audio pour microphone, ligne d'entrée et ligne de sortie

LAN Ethernet Fast (optionnel)

- Supporte le fonctionnement en 10/100Mbps et le fonctionnement en half/full duplex
- Conforme IEEE 802.3/802.3u
- Supporte l'auto négociation IEEE 802.3u clause 28
- Supporte le fonctionnement en mode d'Economie d'Energie d'Interruption de Liaison
- Supporte la compensation de Déviation de Ligne de Base (BLW)
- Egalisation spéculative

USB 2.0

- Conforme aux Spécifications de Bus Série Universel Révision 2.0
- Conforme aux Spécifications d'interface de Contrôleur d'Hôte Amélioré de Intel Révision 1.0
- Conforme aux Spécifications d'Interface de Contrôleur d'Hôte Universel Révision 1.1
- Le périphérique multifonction PCI consiste en deux noyaux de Contrôleur d'Hôtes UHCI pour signalisation pleine/faible vitesse et un noyau de Contrôleur d'Hôtes EHCI pour signalisation haute vitesse
- Le hub racine consiste en 4 ports de face en aval avec émetteurs-récepteurs de couche physique intégrés partagés par le Contrôleur d'Hôte UHCI et EHCI, jusqu'à huit ports fonctionnels
- Support des Spécifications d'Interface de Gestion d'Alimentation de Bus PCI version 1.1

Guide de l'utilisateur de la carte mère

- Support hérité pour tous les ports face à l'aval.

Remarque: Certaines spécifications matérielles et éléments de logiciels peuvent être modifiés sans avertissement.

Funktionen & Checkliste

Checkliste

Die Verpackung Ihres Motherboards enthält folgende Teile:

- Motherboard
- Handbuch
- Bandkabel für Floppylaufwerke (optional)
- Bandkabel für IDE-Laufwerke
- Software -CD

Ausstattung

Unterstütz Socket-A-Prozessoren

- Unterstützt AMD **Athlon XP/Sempron** Prozessoren
- Unterstützung von bis zu **400 MHz** Front-Side Bus (**M863AG**)/ 333 MHz (M863G)

Chipsatz

Dieser Chipsatz besteht aus einer **SiS741/SiS741GX Northbridge** und einer **SiS964L Southbridge**. Die Chipsatzarchitektur ist in einem innovativen und skalierbaren Design gehalten und verspricht sowohl Zuverlässigkeit als auch Leistungsstärke. Diese Mainboardserie besteht aus zwei Modellen, M863AG und M863G:

Modell	Northbridge	Southbridge	Funktion
M863AG	SiS 741	964L	CPU FSB: 400MHz DDR 400
M863G	SiS 741 GX	964L	CPU FSB: 333MHz DDR333/266

- Unterstützt AMD **Athlon XP/Sempron** CPU mit FSB bis zu **400(nur für SiS741 NB)**/333MHz, und Synchrones/Quasisynchrones Host-to-DRAM Timing
- Unterstützt **400(nur für SiS741 NB)**/333/266 SDRAM DDR und High Performance Unified Memory Controller zur Optimierung der DRAM Bus-Nutzung.
- Unterstützt AGP 8X/4X-Interface mit Fast Write-Abwicklung
- Eingebauter 256-Bit 3D Hochleistungsmotor und VLIW Dreieck-Startmotor mit 32-BitFlußpunktformat
- Integriertes mehrfasiges I/O Bindeglied, welches den Zulauf der Datenübertragung stromaufwärts und stromabwärts mit einer 1.2GB/Sek-Bandbreite sicherstellt
- Entspricht PCI 2.2 Spezifikation
- Eingebautes Multithreaded I/O-Link-Mastering
- Multithread I/O Link Mastering mit parallelem Read/Write-Betrieb

Speicherunterstützung

- Zwei 184-pin 2.5V DIMM Steckplätze für DDR SDRAM
- Unterstützung für DDR bis zu **400(nur für SiS741 NB)**/333/266 Speicherbus
- Maximal auf 2GB Speicher erweiterbar

Erweiterungssteckplätze

- Zwei 32-Bit PCI-Steckplätze
- Ein **8X** AGP-Steckplatz
- Ein CNR-Steckplatz

Onboard IDE-Kanäle

- Zwei IDE-Header
- Unterstützt die Modi PIO (Programmable Input/Output) und DMA (Direct Memory Access)
- Unterstützung für IDE Ultra DMA-Busmastering mit Transferraten von 133/100/66 MB/Sek

AC'97 Audio Codec

- 6-Kanäle und gemäß Spezifikationen von Intel AC'97 (REV. 2.3) , entspricht den Anforderungen von Microsoft PC2001
- Fortgeschrittene Betriebsstromzufuhr und stromsparend.
- Stereo Line-in Funktion, geteilt mit Surround-Out.
- Analoges CD Audio Input, pseudo-differential, von hoher Qualität.
- S/PDIF Output-Unterstützung: Output 96 / 48 kHz mit 24 / 20 / 16 Bits.
- Zusätzliche wertvolle Software-Technologie: Unterstützt die meisten PC 3D-Sound Industrienormen und die einzigartige Karaoke-Funktion, welche sich durch das Mikrofon-Echo, Tastatur-Umschaltung und Stoppen mittels Stimme hervorhebt.

Onboard I/O Ports

- Zwei PS/2-Steckplätze für Maus und Tastatur
- Ein serieller Steckplatz
- Ein paralleler Steckplatz
- Ein VGA Steckplatz
- Vier USB 2.0 Ports auf der Rückseite
- Ein LAN Steckplatz (optional)
- Audioanschlüsse für Mikrofon, line-in und line-out

Fast Ethernet LAN (optional)

- Unterstützt 10/100Mbps-Betrieb und halben/vollen Duplex-Betrieb
- Übereinstimmend mit IEEE 802.3/802.3u
- Unterstützt IEEE 802.3u Klausel 28 Selbstentscheidung
- Unterstützt den Betrieb unter dem Modus "Link Down Power Saving" (Verbundener Sparbetrieb)
- Unterstützt Base Line Winder (BLW) - Ausgleich
- Anpassungsfähige Ausgleichung

USB2.0

- Entspricht Universal Serial Bus-Spezifikation, Revision 2.0
- Entspricht Intels Enhanced Host Controller Interface-Spezifikation, Revision 1.0
- Entspricht Universal Host Controller Interface -Spezifikation Revision 1.1
- PCI-Multifunktionsgerät besteht aus zwei UHCI Host Controller-Kernen für Signalübertragung bei voller und niedriger Geschwindigkeit sowie einem EHCI Host Controller-Kern für Hochgeschwindigkeits-Signalübertragung
- Root Hub besteht aus 4 Downstream-Ports mit integrierten Physical Layer-Überträgern für gemeinsame Nutzung durch UHCI und EHCI Host Controller, bis zu acht funktionelle Ausgangsstellen.
- Unterstützt PCI-Bus Power Management Interface , Spezifikation Release 1.1
- Legacy-Unterstützung für alle Downstream-Ports

Hinweis: Bestimmte Hardwarespezifikationen und Teile der softwareausstattung können ohne weitere Ankündigung abgeändert werden.

Guida dell'utente della scheda madre

Traduzione Funzioni e Lista

Lista

L'imballo della scheda madre é composto da:

- La scheda madre
- Il manuale
- Una piattina per il collegamento dei drive (opzionale)
- Una piattina IDE
- Il CD con il Software di supporto

Caratteristiche

Dotata di Socket A per Processori

- Supporto di processori AMD **Athlon XP/Sempron**
- Supporta fino a **400 MHz** (M863AG)/ 333 MHz (M863G) Front Side Bus

Chipset

In accordo ad una architettura scabile e innovative sono presenti nel chipset il **Northbridge SiS741/SiS741GX** e **Southbridge SiS964L**. Di questa scheda madre sono stati sviluppati due modelli: M863AG e M863G:

Modell	Northbridge	Southbridge	Funzione
M863AG	SiS 741	964L	CPU FSB: 400MHz DDR 400
M863G	SiS 741 GX	964L	CPU FSB: 333MHz DDR333/266

- Vengono supportate le CPU AMD **Athlon XP/Sempron**, Athlon e Duron con FSB fino a **400 (solo SiS741 NB)**/333MHz e Timing Sincrono/ Quasi-sincrono Host-to-DRAM.
- Supporto **400(solo SiS741 NB)**/333/266 SDRAM DDR ed é presente un controller ad alte prestazioni in grado di ottimizzare l'utilizzazione del bus DRAM
- Supporto dell'interfaccia AGP 8X/4X con Fast Write Transaction
- Motore 3D a 256 bit con floating point VLIW triangle a 32 bit
- Link I/O Multi-threaded integrato assicura la concorrenza dei trasferimenti upstream/downstream con una larghezza di banda pari a 1.2GB/s
- Compatibile con le specifiche PCI 2.2
- Link mastering I/O multi-threaded integrato
- I/O con Link Mastering Multithread con possibilità di transazione concorrente Read/Write

Memoria Supportata

- Due prese DIMM da 2.5 V a 184 pin per moduli memoria SDRAM DDR
- Supporta bus di memoria **DDR400 (solo SiS741 NB)**/333/266
- Quantità massima di memoria installabile, 2GB

Slot di espansione

- Due slots PCI a 32 bit
- Una slot AGP **8X**
- Una slot CNR

Canali IDE Integrati

- Due connettori IDE

Guida dell'utente della scheda madre

- Supporto della modalità PIO (Programmable Input/Output) e DMA (Direct Memory Access)
- Supporto per le modalità Bus Mastering e Ultra DMA ATA **133/100/66 MB/sec**

AC'97 Audio Codec

- 6 canali, conforme alle specifiche Intel AC'97 (REV. 2.3) ed i requisiti Micro soft PC2001
- Gestione avanzata del risparmio energetico ed "Advanced power management".
- Funzione Stereo Line IN condivisa con Surround out.
- Input Audio CD pseudo differenziale ad alta qualità.
- Supporto Output S/PDIF, Output da 96/48 kHz con 24/20/16 bit.
- Tecnologie software aggiuntive : Supporto della maggior parte degli standard industriali 3D sound PC ed una funzione karaoke dotata di microphone echo, key shifting e vocal cancellation.

Onboard I/O Porte

La scheda madre è dotata da una serie completa di porte e connettori I/O:

- Due porte PS/2 per tastiera e mouse
- Una porta seriale
- Una porta parallela
- Una porta VGA
- Quattro porte USB 2.0 sul retro del pannello
- Una porta LAN (opzionale)
- Jack audio per microfono, ingresso linea e uscita linea

Fast Ethernet LAN (opzionale)

- Operazioni 10/100Mbps e half/full duplex
- Conforme allo standard IEEE 802.3/802.3u
- Negoziazione automatica 28 clause IEEE 802.3u
- Operazioni nella modalità "Link Down Power Saving mode"
- Supporto compensazione Base Line Winder (BLW)
- Adaptive Equalization

USB 2.0

- Conforme alle specifiche Universal Serial Bus 2.0
- Conforme alle specifiche Intel Enhanced Host Controller revisione 1.0
- Conforme alle specifiche Universal Host Controller Interface revisione 1.1
- Il dispositivo PCI multifunzione consiste di due schede di controllo UHCI per la trasmissione segnali pieno/basso e una scheda di controllo EHCI per la trasmissione segnali ad alta velocità.
- Il root hub è composto in 4 porte in downstream facing con ricevitore physical layer integrato condiviso dall'Host Controller UHCI e EHCI sino a otto porte funzionali
- Supporto per interfaccia risparmio energia bus PCI specifiche release 1.1
- Supporto per tutte le porte downstream precedenti

Nota: Alcune specifiche hardware ed elementi software sono soggetti a variazioni senza preavviso.

Guía de Usuario de la Placa Principal

Traducción de Características & Lista

LISTA DE VERIFICACIÓN

El paquete de su placa principal contiene los sigtes. ítems:

- La placa principal
- El Manual del Usuario
- Un cable cinta para el lector de disquete (optativo)
- Un cable cinta para el lector IDE
- CD de Software de soporte

Características

Soporte de Procesador Socket-A

- Soporta procesadores AMD **Athlon XP/Sempron**
- Soporta hasta Bus de Lado Frontal de **400 MHz (M863AG)/ 333 MHz (M863G)**

Chipset

Hay **SiS741/SiS741GX Northbridge** y **SiS964L Southbridge** en este chipset en conformidad con una arquitectura innovadora y escalable con fiabilidad y rendimiento comprobados. La serie de esta placa principal tiene dos modelos, M863AG y M863G:

Modelo	Northbridge	Southbridge	Función
M863AG	SiS 741	964L	CPU FSB: 400MHz DDR 400
M863G	SiS 741 GX	964L	CPU FSB: 333MHz DDR333/266

- Soporta las CPUs AMD **Athlon XP/Sempron** con FSB hasta **400(SiS741 NB solamente)/333 MHz**, y Cronometraje de Anfitrión a DRMA Sincrónico/ Casi-sincrónico
- Soporta **400(SiS741 NB solamente)/333/266 SDRAM DDR** y controlador de memoria unificado de alto rendimiento que optimiza la utilización de bus DRAM
- Soporta Interfaz AGP 8X/4X con Transacción de Escritura Rápida
- Motor 3D de 156-bit de alto rendimiento incorporado y motor de setup de triángulo VLIW de formato de punto flotante de 32-bit
- Vínculo I/O multihilado integrado asegura la concurrencia de la transferencia de datos hacia arriba y abajo con un ancho de banda de 1.2GB/s
- Especificación de conformidad PCI 2.2
- Entrada/Salida multi-ensartada integrada y enlace maestro
- Mastering de vínculo I/O multihilado con transacción Concurrente de Lectura/ Escritura

Soporte de Memoria

- Dos zócalos DIMM de 184-pin 2.5V para los módulos de memoria DDR SDRAM
- Soporta DDR hasta bus de memoria de **400 (solamente SiS741 NB)/333/266**
- Memoria máxima instalada es 2GB

Ranuras de Expansión

- Dos ranuras 32-bit PCI
- Una ranura **8X** AGP
- Una ranura CNR

Canales IDE abordo

- Dos conectores IDE
- Soporta modos PIO (Entrada/Salida Programable/Programmable Input/Output) y modos DMA (Acceso de Memoria Directo/Direct Memory Access).
- Soporta mastering de bus IDE Ultra DMA con índices de transferencia de **133/100/66 MB/seg**

AC'97 Audio Codec

- 6-canales y conforme con la Espec. Intel AC'97 (REV. 2.3), satisface los requisitos de Microsoft PC2001
- Capacidades de administración de alimentación avanzada y ahorro de energía.
- Función Stereo Line-in compartida con Surround out.
- Salida CD Audio pseudo-diferencial analógica de alta calidad.
- Soporte de Salida S/PDIF: Salida de 96 / 48 kHz con 24 / 20 / 16 bits.
- Tecnología de software adicional valiosa: Soporta la mayoría de las normas industriales de PC 3D sound y la función única de karaoke que se caracteriza por el eco de micrófono, cambio a teclados y cancelación a voz.

Puertos I/O Abordos

- Dos puertos PS/2 para ratón y teclado
- Un puerto serial
- Un puerto paralelo
- Un puerto VGA
- Cuatro puertos USB2.0 del panel trasero
- Un puerto LAN (optativo)
- Clavijas de sonido para micrófono, entrada y salida de línea

Fast Ethernet LAN (optativo)

- Soporta operación 10/100Mbps y operación de duplex medio/completo.
- Conformidad IEEE 802.3/802.3u
- Soporta auto-negociación IEEE 802.3u cláusula 28
- Soporta operación bajo el modo Link Down Power Saving (Vincular Ahorro de Suministro)
- Soporta compensación Base Line Winder (BLW)
- Ecuilización Adaptiva.

USB2.0

- Conforme con la Especificación de Bus Serial Universal Revisión 2.0
- Conforme con Controlador Anfitrión Reforzado de Intel Interface Specification Revision 1.0
- Conforme con la Especificación de Interfaz de Controlador Anfitrión Universal Revisión 1.1
- Dispositivo PCI multi-función se consiste de dos centros de Controlador Anfitrión UHCI para señalización de velocidad completa/baja y un centro de Controlador Anfitrión EHCI para señalización de alta velocidad
- Root hub consiste de 4 puertos que miran hacia abajo con transceptores de capa física integrado compartido por Controlador Anfitrión UHCI y EHCI , hasta ocho puertos funcionales
- Soporta Especificación de Interfaz de Administración de Energía de BUS PCI versión 1.1

Guía de Usuario de la Placa Principal

- Soporte de legado para todos los puertos que miran hacia abajo

Nota: Algunas especificaciones de hardware e ítems de software son sujetos a cambio sin aviso previo .

Tradução da Lista & Características

Lista de verificação

A embalagem da sua placa principal contém os seguintes itens:

- A placa principal
- O Manual do Utilizador
- Um cabo para a unidade de disquetes (opcional)
- Um cabo para a unidade IDE
- CD de suporte para o software

Características

Suporte do Processador Socket-A

- Suporta processadores AMD **Athlon XP/Sempron**
- Suporta até **400 MHz** (M863AG)/ 333 MHz (M863G) Front-Side Bus

Chipset

Conta com **SiS741/SiS741GX Northbridge** e **SiS964L Southbridge** neste chipset, de acordo com uma arquitectura inovadora e escalável com um nível de confiança e desempenho comprovado. Esta série de placa mãe possui dois modelos, M863AG e M863G:

Modelo	Northbridge	Southbridge	Função
M863AG	SiS 741	964L	CPU FSB: 400MHz DDR 400
M863G	SiS 741 GX	964L	CPU FSB: 333MHz DDR333/266

- Suporta AMD **Athlon XP/Sempron** CPU com FSB até **400(apenas para SiS741 NB)**/333 MHz, e Síncrono / Quasi-síncrono Host-para-DRAM Timing
- Suporta **400(apenas para SiS741 NB)**/333/266 SDRAM DDR e controlador de memória unificada de alta performance otimizando o uso do DRAM bus
- Suporta Interface *c*/ Transação de Escrita Rápida AGP 8X/4X
- Engenho de alta performance embutido de 256-bit 3D e formato de ponto flutuante de 32-bit engenho de configuração triangular VLIW
- Linque I/O Multi-entrelaçado assegurando a concorrência de correntes de transferência de dados para cima/para baixo com banda de 1.2GB/s
- Especificação PCI 2.2 Compatível
- Linque mestre multi-entrelaçado I/O
- I/O link Mastering Interlaceado com transação Concurrente Read/Write

Suporte de memória

- Dois fichas DIMM 2.5V com 184 pinos para módulos de memória DDR SDRAM
- Suporta bus de memória DDR **400(apenas para SiS741 NB)**/333/266 memory bus
- A memória máxima instalada é de 2GB

Slots de expansão

- Dois slots PCI de 32 bit
- Um slot AGP **8X**
- Um slot CNR

Canais IDE na placa

- Dois conectores IDE

Guia de Utilizador da Motherboard

- Suporta modos PIO (Input/Output Programável) e DMA (Direct Memory Access)
- Suporta IDE Ultra DMA bus mastering com razão de transferência de **133/100/66 MB/seg**

AC'97 Audio Codec

- 6- canais e complacente com Especificação Intel AC'97 (REV. 2.3) , de acordo com os requerimentos da Microsoft PC2001
- Gerenciamento de força avançada e capacidade de economia de energia.
- Função Stereo Line-in compatível com a saída do Surround.
- Input de CD Áudio análogo pseudo diferencial de alta qualidade.
- Suporte da Saída S/PDIF: Saída de 96 / 48 kHz com 24 / 20 / 16 bits.
- Tecnologia add-on software valiosa: Suporta a maioria dos padrões industriais de som de PC 3D e função única de karaoke caracterizado com suporte para microfone eco, troca de tom e cancelamento vocal.

Portas I/O na placa

- Dois portas PS/2 para o rato e teclado
- Uma porta série
- Uma porta paralela
- Uma porta VGA
- Quatro portas USB2.0 instaladas no painel traseiro
- Uma porta LAN (opcional)
- Jacks audio para microfone, line-in e line-out

Fast Ethernet LAN (opcional)

- Suporta operação 10/100Mbps e operação parcial/completa duplex
- IEEE 802.3/802.3u complacente
- Suporta IEEE 802.3u cláusula 28 auto negociação
- Suporta operação sob o modo Link Down Power Saving
- Suporta compensação Base Line Winder (BLW)
- Equalização Adaptativa

USB 2.0

- Compatível com Universal Serial Bus Revisão 2.0 da especificação
- Compatível com controlador Enhanced Host da Intel Revisão 1.0 da especificação da interface
- Compatível com controlador Universal Host Revisão 1.1 da especificação da Interface
- O dispositivo PCI multi-funções consiste em dois núcleos de Controlador UHCI Host Controller para sinalização de velocidade total/baixa em um núcleo de Controlador EHCI Host para sinalização de alta velocidade
- O núcleo de raiz consiste em 4 portas de protecção a jusante com transceptores de camadas físicas integrados partilhados pelos controladores Host UHCI e EHCI, até oito tomadas funcionais
- Suporte de gestão de energia PCI-Bus Revisão 1.1 da especificação da interface
- Suporte para todas as portas de protecção a jusante

Nota: As especificações de alguns artigos de hardware e software encontram-se sujeitos a alterações sem aviso prévio.

功能和检查单翻译

检查单

您的主板包装含有以下项目：

- 主板
- 用户手册
- 一根磁盘驱动器扁平电缆（可选）
- 一根 IDE 驱动器扁平电缆
- 软件支持 CD

功能

支持 Socket-A 处理器

- 支持 AMD Athlon XP/Sempron 处理器
- 支持400 MHz (M863AG)/ 333 MHz (M863G) 前端总线

芯片组

芯片组包含SiS741/SiS741GX北桥 和SiS964L南桥，它基于一种新型的、可扩展的架构，能提供已经证明的可靠性和高性能。此主板系列有两种型号，M863AG 和 M863G：

型号	北桥	南桥	功能
M863AG	SiS 741	964L	CPU FSB: 400MHz DDR 400
M863G	SiS 741 GX	964L	CPU FSB: 333MHz DDR333/266

- 支持最高 FSB 为 400（只支持SiS741 NB）/333MHz 的 AMD Athlon XP/Sempron CPU, 支持同步/准同步主机到 DRAM 定时
- 支持400（只支持SiS741 NB）/333/266 DDR SDRAM和对 DRAM 总线利用率进行优化的高性能标准存储控制器
- 支持带有 Fast Write Transaction 的 AGP 8X/4X 接口
- 内建高性能 256 位 3D 引擎和 32 位浮点式 VLIW 三角设置引擎
- 集成多线程 I/O 连接，确保 1.2GB/s 带宽的并发上行/下行数据传输
- 符合 PCI 2.2 规格
- 集成多线程 I/O 连接
- 带读/写并发处理的多线程 I/O 连接主控

内存支持

- 两个用于 DDR SDRAM 内存条的 184-pin 2.5V DIMM 插槽
- 支持 DDR 400（只支持SiS741 NB）/333/266 存储总线
- 内存最多可达 2GB

扩展槽

- 2 个 32 位 PCI 插槽
- 1 个 8XAGP 插槽
- 1 个 CNR 插槽

主板用户指南

Onboard IDE 通道

- 2 个 IDE 接口
- 支持 PIO (程控输入/输出) 和 DMA (直接存储器存取) 模式
- 支持 IDE Ultra DMA 总线控制, 传输速率可达 133/100/66 MB/sec

AC'97 编解码器

- 6 通道, 符合 Intel AC'97 (REV. 2.3) 规格, 满足 Microsoft PC2001 要求
- 高级电源管理和节电功能。
- 共享环绕输出的立体声线入功能。
- 高质量伪差分模拟 CD 音频输入。
- 支持 S/PDIF 输出: 输出 96 / 48 kHz, 24 / 20 / 16 位
- 增值软件技术。支持大部分 PC 3D 立体声行业标准和卡拉 OK 功能, 支持话筒回声消除、键移动和声音消除功能

集成 I/O 端口

此主板具有完整的 I/O 端口和插孔:

- 2 个用于连接鼠标和键盘的 PS/2 端口
- 1 个串口
- 1 个并口
- 1 个 VGA 端口
- 4 个后面板 USB2.0 端口
- 1 个 LAN 端口 (可选)
- 麦克风、线入和线出声音插孔

快速以太网 LAN (可选)

- 支持 10/100Mbps 工作和半/全双工工作
- 符合 IEEE 802.3/802.3u 标准
- 支持 IEEE 802.3u 第 28 项的自协商
- 支持链路故障节电模式下操作
- 支持基线漂移 (BLW) 补偿
- 自适应均衡

USB 2.0

- 符合通用串行总线规格 2.0 版本
- 符合 Intel 1.0 版本的增强主控器接口规格
- 符合 1.1 版本的通用主控器接口规格
- PCI 多功能设备由 2 个用于全速/低速传输数据的 UHCI 主控器和 1 个用于高速传输数据的 EHCI 主控器组成
- Root 集线器包括 4 个下行端口, 带有与 UHCI 和 EHCI 主控制器共用的集成物理层收发器, 最多 8 个功能端口
- 支持 1.1 版本的 PCI 总线电源管理接口规格
- 支持所有传统下行端口

说明: 某些硬件规格和软件项目若有更改恕不另行通知。

Chapter 1 Introduction

This motherboard has a **Socket-A** support for the **AMD Athlon XP/Sempron** processors. The Socket-A processor's front-side bus speed is **400 MHz (for M863AG)**/333 MHz (for M863G).

This motherboard has the **SiS741/741GX** Northbridge and **SiS964L** Southbridge that supports the **AC' 97 audio codec**, the **Ultra DMA 133/100/66** function, and the built-in **USB 2.0** providing higher bandwidth. It implements **Universal Serial Bus Specification Revision 2.0** and is compliant with **UHCI 1.1** and **EHCI 0.95**.

It has two 32-bit **PCI** slots, one **8X AGP** slot, one **CNR** (Communications and Networking Riser) slot, and supports the onboard **10BaseT/100BaseTX Network** interface (optional). In addition, this motherboard has a full set of I/O ports including two PS/2 ports for mouse and keyboard, one serial port, one VGA port, one parallel port, three audio jacks for line-in, line-out and microphone, four back-panel **USB2.0** ports. Two onboard USB headers provide additional USB2.0 ports by connecting the Extended USB Module to the motherboard.

This motherboard is a **Micro ATX size** motherboard and has power connectors for an ATX power supply.

Note: M863AG with SiS741NB and SiS964L SB supports FSB **400MHz** and **DDR400**; M863G with SiS741 GX NB and SiS964L SB, FSB333MHz and DDR333/266.

Key Features

The key features of this motherboard include:

Socket-A Processor Support

- Supports **AMD Athlon XP/ Sempron** processors
- Supports up to **400 MHz (for M863AG)** or 333 MHz (for M863G) Front-Side Bus

Chipset

There are **SiS741/SiS741GX Northbridge** and **SiS964L Southbridge** in this chipset in accordance with an innovative and scalable architecture with proven reliability and performance. This motherboard series has two models, M863AG and M863G:

Model	Northbridge	Southbridge	Function
M863AG	SiS 741	964L	CPU FSB: 400MHz , DDR400
M863G	SiS 741GX	964L	CPU FSB: 333MHz, DDR333/266

Motherboard User's Guide

- Supports AMD **Athlon XP/Sempron** CPU with FSB up to **400(only for SiS741 NB)**/333 MHz, and Synchronous/ Quasi-synchronous Host-to-DRAM Timing
- Supports **400(only for SiS741 NB)**/333/266 DDR SDRAM and high performance unified memory controller optimizing the DRAM bus utilization
- Supports AGP 8X/4X Interface w/ Fast Write Transaction
- Built-in a high performance 256-bit 3D engine and 32-bit floating point format VLIW triangle setup engine
- Integrated Multi-threaded I/O link ensures concurrency of upstream/down stream data transfer with 1.2GB/s bandwidth
- PCI 2.2 Specification Compliance
- Integrated Multithreaded IO Link Mastering
- Multithread I/O link Mastering with Read/Write Concurrent transaction

Memory Support

- Two 184-pin, 2.5V DIMM sockets for DDR SDRAM memory modules
- Supports DDR **400(only for SiS741 NB)**/333/266 memory bus
- Maximum installed memory is 2GB

Expansion Slots

- Two 32-bit PCI slots
- One **8X AGP** slot
- One CNR (Communications and Networking Riser) slot

Onboard IDE channels

- Two IDE Connectors
- Supports PIO (Programmable Input/Output) and DMA (Direct Memory Access) modes
- Supports IDE Ultra DMA bus mastering with transfer rates of **133/100/66 MB/sec**

AC'97 Codec

- 6- channel and compliant with Intel AC'97 (REV. 2.3) Spec, meeting with Microsoft PC2001 requirements
- Advanced power management and power saving capabilities.
- Stereo Line-in function shared with Surround out.
- High quality pseudo-differential analog CD Audio input.
- S/PDIF Output support: Output 96 / 48 kHz with 24 / 20 / 16 bits
- Valuable add-on software technology: Support most industry standards of PC 3D sound and unique karaoke function support featured with microphone echo, key shifting, and vocal cancellation.

Onboard I/O Ports

- Two PS/2 ports for mouse and keyboard
- One serial port

- One parallel port
- One VGA port
- Four back-panel USB2.0 ports
- One LAN port (optional)
- Audio jacks for microphone, line-in and line-out

Fast Ethernet LAN (optional)

- Supports 10/100Mbps operation and half/full duplex operation
- IEEE 802.3/802.3u compliant
- Supports IEEE 802.3u clause 28 auto negotiation
- Supports operation under Link Down Power Saving mode
- Supports Base Line Winder (BLW) compensation
- Adaptive Equalization

USB 2.0

- Compliant with Universal Serial Bus Specification Revision 2.0
- Compliant with Intel's Enhanced Host Controller Interface Specification Revision 1.0
- Compliant with Universal Host Controller Interface Specification Revision 1.1
- PCI multi-function device consists of two **UHCI Host Controller** cores for full-/low-speed signaling and one **EHCI Host Controller** core for high-speed signaling
- Root hub consists 4 downstream facing ports with integrated physical layer transceivers shared by UHCI and EHCI Host Controller, up to eight functional ports
- Support PCI-Bus Power Management Interface Specification release 1.1
- Legacy support for all downstream facing ports

BIOS Firmware

This motherboard uses AMI BIOS that enables users to configure many system features including the following:

- Power management
- Wake-up alarms
- CPU parameters and memory timing
- CPU and memory timing

The firmware can also be used to set parameters for different processor clock speeds.

Dimensions

- Micro ATX form factor of 244 x 200 mm

Note: Hardware specifications and software items are subject to change without notification.

Motherboard User's Guide

Package Contents

Your motherboard package ships with the following items:

- ❑ The motherboard
- ❑ The User's Guide
- ❑ One diskette drive ribbon cable (optional)
- ❑ One IDE drive ribbon cable
- ❑ The Software support CD

Optional Accessories

You can purchase the following optional accessories for this mainboard.

- ❑ The Extended USB module
- ❑ The CNR v.90 56K Fax/Modem card

Note: You can purchase your own optional accessories from the third party, but please contact your local vendor on any issues of the specification and compatibility.

Chapter 2 Motherboard Installation

To install this motherboard in a system, please follow these instructions in this chapter:

- ❑ Identify the motherboard components
- ❑ Install a CPU
- ❑ Install one or more system memory modules
- ❑ Make sure all jumpers and switches are set correctly
- ❑ Install this motherboard in a system chassis (case)
- ❑ Connect any extension brackets or cables to headers/connectors on the motherboard
- ❑ Install peripheral devices and make the appropriate connections to headers/connectors on the motherboard

Note:

1. Before installing this motherboard, make sure jumper JP2 is under Normal setting. See this chapter for information about locating JP2 and the setting options.
2. Never connect power to the system during installation; otherwise, it may damage the motherboard.

Motherboard User's Guide

Motherboard Components

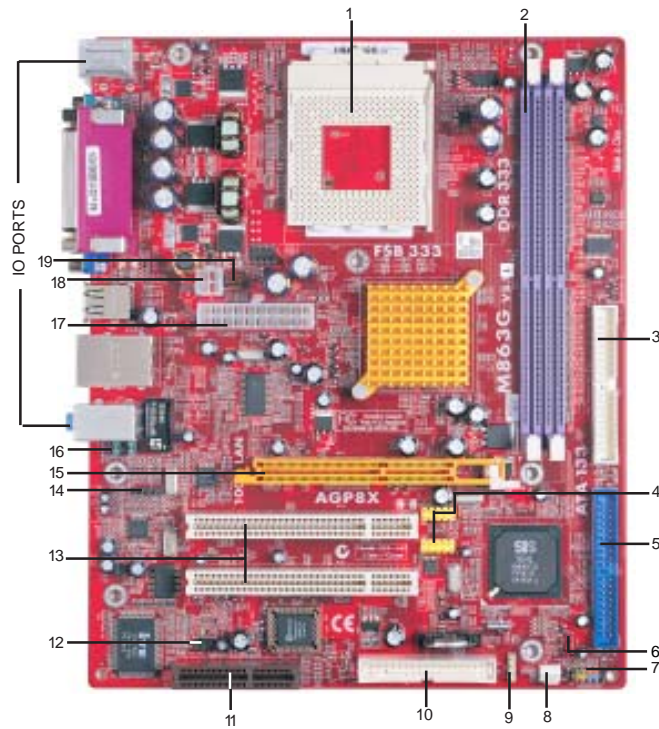

ITEM	LABEL	COMPONENTS	COLOR
1	DDR1/2	184-pin DDR SDRAM sockets	PURPLE
2	IDE2	Primary/Sceondary IDE connector	WHITE
3	USB2/3	Front Panel USB headers	YELLOW
4	IDE1	Primary/Sceondary IDE connector	BLUE
5	JP2	Clear CMOS jumper	RED
6	SW1	Front Panel Sw itch/LED header	COLOR
7	SY SFAN1	System Fan connector	WHITE
8	SPK1	Speaker header	LIME
9	FDC1	Floppy Disk Drive connector	WHITE
10	CNR1	CNR slot	BROWN
11	IR1	Infrared header	BLACK
12	PCI 1-2	32-bit PCI slots	WHITE
13	CD1	Analog Audio Input header	BLACK
14	AGP1	AGP slot	ORANGE
15	AUDIO1	Front Panel Audio header	PURPLE
16	U5	Standard 20-Pin ATX Pow er connector	WHITE
17	J1	Standard 4-Pin ATX Pow er connector	WHITE
18	CPUFAN1	CPU Fan connector	DARK RED

I/O Ports

This is a side view of the built-in I/O ports on the motherboard.

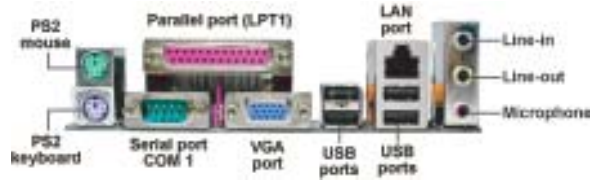

PS/2 Mouse	Use the upper PS/2 port to connect a PS/2 pointing device.
PS/2 Keyboard	Use the lower PS/2 port to connect a PS/2 keyboard.
Parallel Port (LPT1)	Use the Parallel port to connect printers or other parallel communications devices.
Serial Port (COM1)	Use the COM port to connect serial devices such as mice or fax/modems. COM1 is identified by the system as COM1.
VGA Port	Use the VGA port to connect VGA devices.
LAN Port (optional)	Connect an RJ-45 jack to the LAN port to connect your computer to the Network.
USB Ports	Use the USB ports to connect USB devices.
Audio Ports	Use these three audio jacks to connect audio devices. The first jack is for stereo Line-In signal, the second jack for stereo Line-Out signal, and the third jack for Microphone.

Installing the Processor

This motherboard has a Socket 462 processor socket. When choosing a processor, consider the performance requirements of the system. Performance is based on the processor design, the clock speed and system bus frequency of the processor, and the quantity of internal cache memory and external cache memory.

CPU Installation Procedure

Follow these instructions to install the CPU:

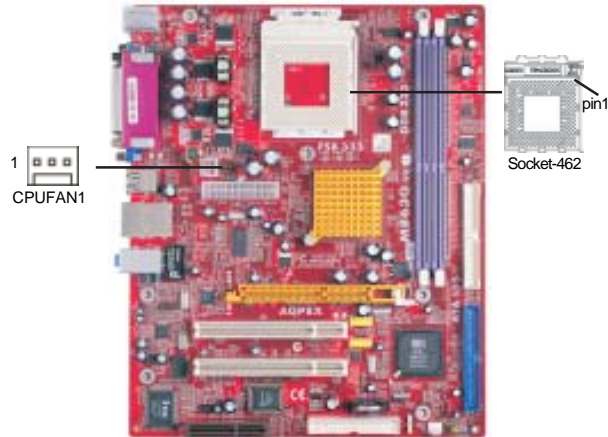

- 1 Unhook the locking lever of the CPU socket. Pull the locking lever away from the socket and raising it to the upright position.
- 2 Match the pin1 corner marked as the beveled edge on the CPU with the pin1 corner on the socket. Insert the CPU into the socket. Do not use force.
- 3 Push the locking lever down and hook it under the latch on the edge of socket.
- 4 Apply thermal grease to the top of the CPU.
- 5 Install the cooling fan/heatsink unit onto the CPU, and secure them all onto the socket base.
- 6 Plug the CPU fan power cable into the CPU fan connector (CPUFAN1) on the motherboard.



Installing Memory Modules

This motherboard accommodates two 184-pin 2.5V DIMM sockets (Dual Inline Memory Module) for unbuffered **DDR 400**/333/266 memory modules (Double Data Rate SDRAM), and maximum 2.0 GB installed memory.

DDR SDRAM is a type of SDRAM that supports data transfers on both edges of each clock cycle (the rising and falling edges), effectively doubling the memory chip's data throughput. DDR DIMMs can synchronously work with 166 MHz or 200 MHz memory bus.

DDR SDRAM provides 2.1 GB/s, 2.7 GB/s or 3.2GB/s data transfer rate when the bus is 133 MHz, 166 MHz or 200 MHz, respectively.

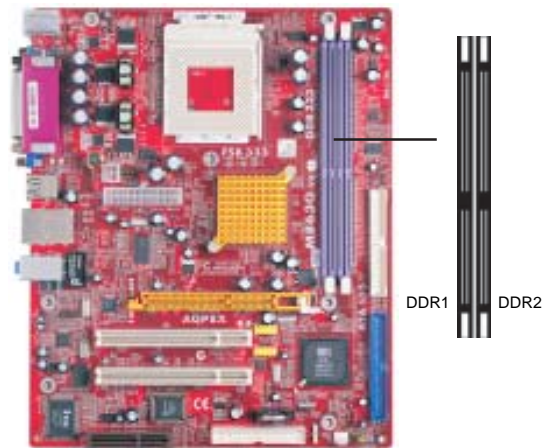

Memory Module Installation Procedure

These modules can be installed with up to 2 GB system memory. Refer to the following to install the memory module.

1. Push down the latches on both sides of the DIMM socket.
2. Align the memory module with the socket. There is a notch on the DIMM socket that you can install the DIMM module in the correct direction. Match the cutout on the DIMM module with the notch on the DIMM socket.
3. Install the DIMM module into the socket and press it firmly down until it is seated correctly. The socket latches are levered upwards and latch on to the edges of the DIMM.

Motherboard User's Guide

4. Install any remaining DIMM modules.



Jumper Settings

Connecting two pins with a jumper cap is **SHORT**; removing a jumper cap from these pins, **OPEN**.



JP2: Clear CMOS Jumper

Use this jumper to clear the contents of the CMOS memory. You may need to clear the CMOS memory if the settings in the Setup Utility are incorrect and prevent your motherboard from operating. To clear the CMOS memory, disconnect all the power cables from the motherboard and then move the jumper cap into the **CLEAR** setting for a few seconds.

Function	Jumper
Clear CMOS	Short Pins 1-2
Normal	Short Pins 2-3

Note: To avoid the system instability after clearing CMOS, we recommend users to enter the main BIOS setting page to "Load Optimal De-faults" and then "Save Changes and Exit".

Install the Motherboard

Install the motherboard in a system chassis (case). The board is a Micro ATX size motherboard. You can install this motherboard in an ATX case. Make sure your case has an I/O cover plate matching the ports on this motherboard.

Install the motherboard in a case. Follow the case manufacturer's instructions to use the hardware and internal mounting points on the chassis.

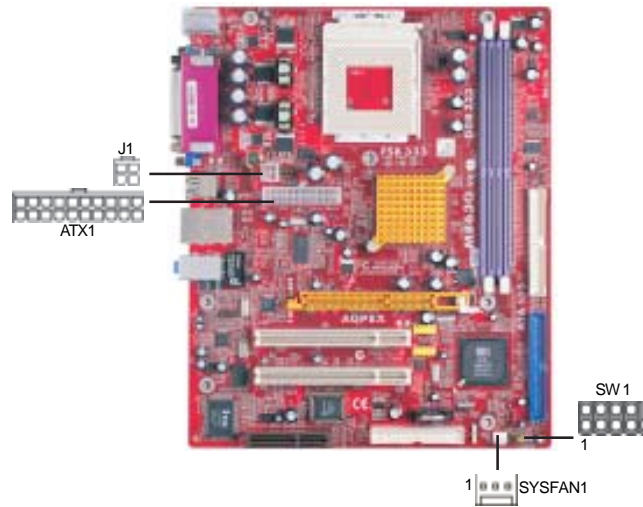

Connect the power connector from the power supply to the **ATX1** connector on the motherboard. **J1** is a +12V connector for CPU Vcore power.

If there is a cooling fan installed in the system chassis, connect the cable from the cooling fan to the **CHSFAN1** fan power connector on the motherboard.

Connect the case switches and indicator LEDs to the **SW1** header.

Pin	Signal	Pin	Signal
1	HD_LED_P(+)	2	FP PWR/SLP(+)
3	HD_LED_N(-)	4	FP PWR/SLP(-)
5	RESET_SW_N(-)	6	POWER_SW_P(+)
7	RESET_SW_P(+)	8	POWER_SW_N(-)
9	RSVD_DNU	10	KEY

Connecting Optional Devices

Refer to the following for information on connecting the motherboard's optional devices:

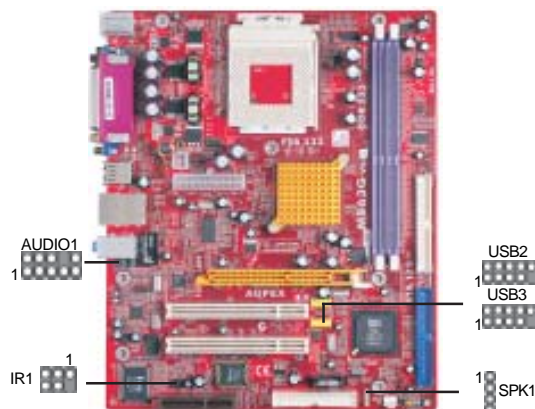

SPK1: Speaker Header

Connect the cable from the PC speaker to the SPK1 header on the motherboard.

Pin	Signal
1	SPKR
2	NC
3	GND
4	+5V

AUDIO1: Front Panel Audio Header

This header allows the user to install auxiliary front-oriented microphone and line-out ports for easier access.

Pin	Signal	Pin	Signal
1	AUD_MIC	2	AUD_GND
3	AUD_MIC_BIAS	4	AUD_VCC
5	AUD_FPOUT_R	6	AUD_RET_R
7	HP_ON	8	KEY
9	AUD_FPOUT_L	10	AUD_RET_L

USB2/USB3: Front panel USB Header

The motherboard has USB ports installed on the rear edge I/O port array. Additionally, some computer cases have USB ports at the front of the case. If you have this kind of case, use auxiliary USB headers USB2/USB3 to connect the front-mounted ports to the motherboard.

Pin	Signal	Pin	Signal
1	VERG_FP_USBPWR0	2	VERG_FP_USBPWR0
3	USB_FP_P0(-)	4	USB_FP_P1(-)
5	USB_FP_P0(+)	6	USB_FP_P1(+)
7	GROUND	8	GROUND
9	KEY	10	USB_FP_OC0

1. Locate the USB2/USB3 header on the motherboard.
2. Plug the bracket cable onto the USB2/USB3 header.
3. Remove a slot cover from one of the expansion slots on the system chassis. Install an extension bracket in the opening. Secure the extension bracket to the chassis with a screw.

IR1: Infrared Port

The infrared port allows the wireless exchange of information between your computer and similarly equipped devices such as printers, laptops, Personal Digital Assistants (PDAs), and other computers.

Pin	Signal	Pin	Signal
1	NC	2	KEY
3	+5V	4	GND
5	IRTX	6	IRRX

1. Locate the infrared port-**IR1** header on the motherboard.
2. If you are adding an infrared port, connect the ribbon cable from the port to the IR1 header and then secure the port to an appropriate place in your system chassis.

Install Other Devices

Install and connect any other devices in the system following the steps below.

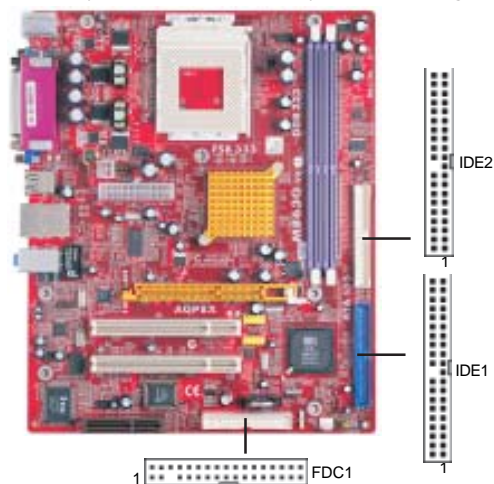

Floppy Disk Drive

The motherboard ships with a floppy disk drive cable that can support one or two drives. Drives can be 3.5" or 5.25" wide, with capacities of 360K, 720K, 1.2MB, 1.44MB, or 2.88MB.

Install your drives and connect power from the system power supply. Use the cable provided to connect the drives to the floppy disk drive connector **FDC1**.

IDE Devices

IDE devices include hard disk drives, high-density diskette drives, and CD-ROM or DVD-ROM drives, among others.

The motherboard ships with an IDE cable that can support one or two IDE devices. If you connect two devices to a single cable, you must configure one of the drives as Master and one of the drives as Slave. The documentation of the IDE device will tell you how to configure the device as a Master or Slave device. The Master device connects to the end of the cable.

Install the device(s) and connect power from the system power supply. Use the cable provided to connect the device(s) to the Primary IDE channel connector **IDE1** on the motherboard.

If you want to install more IDE devices, you can purchase a second IDE cable and connect one or two devices to the Secondary IDE channel connector **IDE2** on the motherboard. If you have two devices on the cable, one must be Master and one must be Slave.

Analog Audio Input Header

If you have installed a CD-ROM drive or DVD-ROM drive, you can connect the drive audio cable to the onboard sound system.

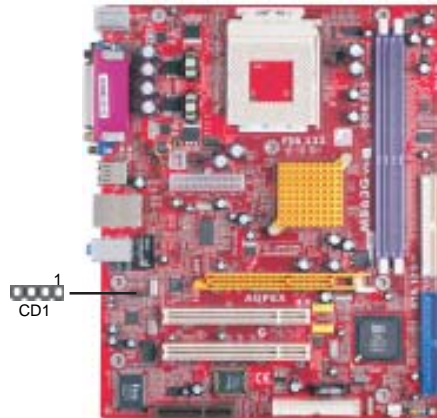

When you first start up your system, the BIOS should automatically detect your CD-ROM/DVD drive. If it doesn't, enter the Setup Utility and configure the CD-ROM/DVD drive that you have installed. On the motherboard, locate the 4-pin connector **CD1**.

Pin	Signal
1	CD IN L
2	GND
3	GND
4	CD IN R

Expansion Slots

This motherboard has one AGP, CNR and two 32-bit PCI slots.

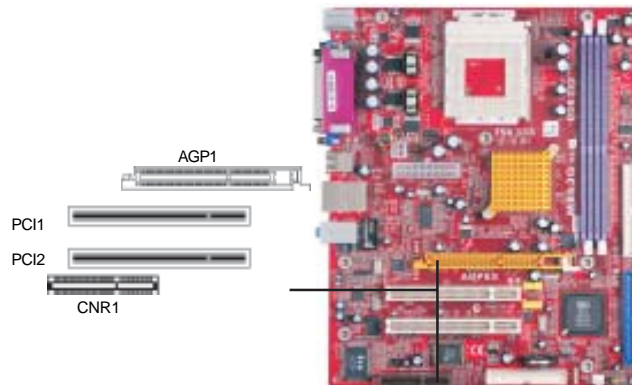

Follow the steps below to install an AGP/CNR/PCI expansion card.

1. Locate the AGP, CNR or PCI slots on the motherboard.
2. Remove the blanking plate of the slot from the system chassis.
3. Install the edge connector of the expansion card into the slot. Ensure the edge connector is correctly seated in the slot.
4. Secure the metal bracket of the card to the system chassis with a screw.



8X AGP Slot

You can install a graphics adapter that supports the 8x AGP specification and has a 8X AGP edge connector in the AGP slot.

CNR Slot

You can install the CNR (Communications and Networking Riser) cards in this slot, including LAN, Modem and Audio functions.

PCI Slots

You can install the 32-bit PCI interface expansion cards in the slots.

Chapter 3 BIOS Setup Utility

Introduction

The BIOS Setup Utility records settings and information of your computer, such as date and time, the type of hardware installed, and various configuration settings. Your computer applies the information to initialize all the components when booting up and basic functions of coordination between system components.

If the Setup Utility configuration is incorrect, it may cause the system to malfunction. It can even stop your computer booting properly. If it happens, you can use the clear CMOS jumper to clear the CMOS memory which has stored the configuration information; or you can hold down the **Page Up** key while rebooting your computer. Holding down the **Page Up** key also clears the setup information.

You can run the setup utility and manually change the configuration. You might need to do this to configure some hardware installed in or connected to the motherboard, such as the CPU, system memory, disk drives, etc.

Running the Setup Utility

Every time you start your computer, a message appears on the screen before the operating system loading that prompts you to “Hit if you want to run SETUP”. Whenever you see this message, press the **Delete** key, and the Main menu page of the Setup Utility appears on your monitor.

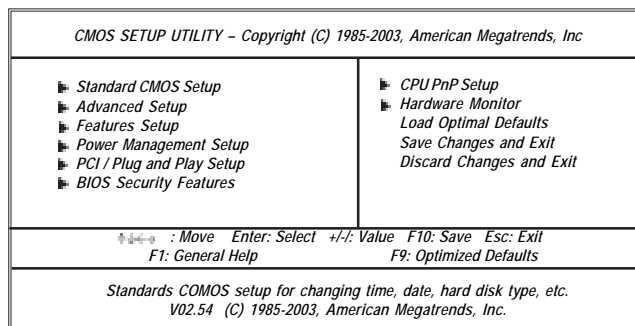

You can use cursor arrow keys to highlight anyone of options on the main menu page. Press **Enter** to select the highlighted option. Press the **Escape** key to leave the setup utility. Press +/- to modify the selected field's values.

Motherboard User's Guide

Some options on the main menu page lead to tables of items with installed values that you can use cursor arrow keys to highlight one item, and press **PgUp** and **PgDn** keys to cycle through alternative values of that item. The other options on the main menu page lead to dialog boxes requiring your answer OK or Cancel by selecting the **[OK]** or **[Cancel]**.

If you have already changed the setup utility, press **F10** to save those changes and exit the utility. Press **F1** to display a screen describing all key functions. Press **F9** to install the setup utility with a set of default values.

Standard CMOS Setup Page

This page displays a table of items defining basic information about your system.

CMOS SETUP UTILITY - Copyright (C) 1985-2003, American Megatrends, Inc. Standard CMOS Setup		
System Time	00:004:12	Help Item
System Date	Mon 04/05/2004	
Primary IDE Master	Not Detected	User [Enter], [TAB] or [SHIFT-TAB] to select a field. Use [+] or [-] to configure system time.
Primary IDE Slave	Not Detected	
Secondary IDE Master	Not Detected	
Secondary IDE Slave	Not Detected	
Floppy A	1.44 MB 3 1/2	
Floppy B	Disabled	
← →: Move Enter: Select +/-: Value F10: Save Esc: Exit F1: General Help F9: Optimized Defaults		

Date & Time

These items set up system date and time.

Primary IDE Master/Primary IDE Slave/Secondary IDE Master/Secondary IDE Slave

Use these items to configure devices connected to the Primary/Secondary IDE channels. To configure an IDE hard disk drive, choose *Auto*. If the *Auto* setting fails to find a hard disk drive, set it to *User*, and then fill in the hard disk characteristics (Size, Cyls, etc.) manually. If you have a CD-ROM drive, select the setting *CDROM*. If you have an ATAPI device with removable media (e.g. a ZIP drive or an LS-120), select *Floptical*.

Floppy A/B

These items set up size and capacity of the floppy diskette drive(s) installed in the system.

Advanced Setup Page

This page sets up more advanced information about your system. Handle this page with caution. Any changes can affect the operation of your computer.

CMOS SETUP UTILITY - Copyright (C) 1985-2003, American Megatrends, Inc.		
Advanced Setup		
		Help Item
Share Memory Size	32 MB	
Quick Boot	Enabled	
1 st Boot Device	IDE:PM-ST320410A	Allows BIOS to skip certain tests while booting.
2 nd Boot Device	SS-Pioneer DVD-RO	This will decrease the time needed to boot the system.
3 rd Boot Device	1 st FLOPPY DRIVE	
Try Other Boot Device	Yes	
Bootup Num-Lock	On	
Boot To OS/2 > 64MB	No	
Graphic Win Size	64 MB	
DRAM CAS# Latency	SPD	
Auto Detect DIMM/PCI C1K	Enabled	
Spread Spectrum	Disabled	

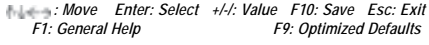
 : Move Enter: Select +/-: Value F10: Save Esc: Exit
 F1: General Help F9: Optimized Defaults

Share Memory Size

This item lets you allocate a portion of the main memory for the onboard VGA display application with several options.

Quick Boot

If you enable this item, the system starts up more quickly by elimination of some of the power on test routines.

1st Boot Device/2nd Boot Device/3rd Boot Device

Use these items to determine the device order the computer uses to look for an operating system to load at start-up time.

Try Other Boot Device

If you enable this item, the system will also search for other boot devices if it fails to find an operating system from the first two locations.

BootUp Num-Lock

This item determines if the Num Lock key is active or inactive at system start-up time.

Boot to OS/2 > 64MB

Enable this item if you are booting the OS/2 operating system and you have more than 64MB of system memory installed.

Graphic Win Size

This item defines the size of aperture if you use a graphic adapter.

Motherboard User's Guide

DRAM CAS# Latency

This item determines the operation of DRAM memory CAS (column address strobe). It is recommended that you leave this item at the default value. The 2T setting requires faster memory that specifically supports this mode.

Auto detect DIMM/PCI Clock

When this item is enabled, BIOS will disable the clock signal of free DIMM/PCI slots.

Spread Spectrum

If you enable spread spectrum, it can significantly reduce the EMI (Electro-Magnetic interface) generated by the system.

Features Setup Page

This page sets up some parameters for peripheral devices connected to the system.

CMOS SETUP UTILITY - Copyright (C) 1985-2003, American Megatrends, Inc. Features Setup			
OnBoard Floppy Controller	Enabled	Help Item	
Serial Port1 Address	3F8/IRQ4	Allows BIOS to Enable or Disable Floppy Controller.	
OnBoard IR Port	Disabled		
Parallel Port Address	378		
Parallel Port Mode	ECP		
ECP Mode DMA Chnnel	DMA3		
Parallel Port IRQ	IRQ7		
OnBoard PCI IDE Controller	Both		
Audio Device	Enabled		
Modem Device	Auto		
Ethernet Device	Enabled		
OnBoard USB Function	Enabled		
USB Function For DOS	Disabled		
← → : Move Enter: Select +/-: Value F10: Save Esc: Exit F1: General Help F9: Optimized Defaults			

OnBoard Floppy Controller

Use this item to enable or disable the onboard floppy disk drive interface.

Serial Port1 Address

Use this item to enable or disable the onboard COM1/2 serial port, and to assign a port address.

OnBoard IR Port

Use this item to enable or disable the onboard infrared port, and to assign a port address.

Parallel Port Address

Use this item to enable or disable the onboard Parallel port, and to assign a port address.

Parallel Port Mode

Use this item to set the parallel port mode. You can select ECP (Extended Capabilities Port).

ECP Mode DMA Channel

Use this item to assign a DMA channel to the parallel port.

Parallel Port IRQ

Use this item to assign IRQ to the parallel port.

OnBoard PCI IDE Controller

Use this item to enable or disable both of the onboard Primary and Secondary IDE channels.

Audio Device

This item enables or disables the AC'97 audio chip.

Modem Device

This item enables or disables the onboard Modem.

Ethernet Device

This item enables or disables the onboard Ethernet LAN.

OnBoard USB Function

Enable this item if you plan to use the USB ports on this motherboard.

USB Function For DOS

Enable this item if you plan to use the USB ports on this motherboard in a DOS environment.

Power Management Setup Page

This page sets some parameters for system power management operation.

<i>CMOS SETUP UTILITY - Copyright (C) 1985-2003, American Megatrends, Inc. Power Management Setup</i>		
<i>ACPI Aware O/S</i>	<i>Yes</i>	<i>Help Item</i>
<i>Power Management</i>	<i>Enabled</i>	<i>Enable / Disable</i>
<i>Suspend Mode</i>	<i>S1</i>	<i>ACPI support for</i>
<i>Suspend Time Out</i>	<i>Disabled</i>	<i>Operating System.</i>
<i>Resume On RTC Alarm</i>	<i>Disabled</i>	<i>Enable: If OS supports</i>
<i>Keyboard Power On</i>	<i>Disabled</i>	<i>ACPI.</i>
<i>LAN/Ring Power On</i>	<i>Disabled</i>	<i>Disable: If OS does not</i>
		<i>support ACPI.</i>
<i>↑↓←→ : Move Enter: Select +/-: Value F10: Save Esc: Exit</i>		
<i>F1: General Help F9: Optimized Defaults</i>		

ACPI Aware O/S

This item supports ACPI (Advanced Configuration and Power management Interface). Use this item to enable or disable the ACPI feature.

Motherboard User's Guide

Power Management

Use this item to enable or disable a power management scheme. If you enable power management, you can use the items below to set the power management operation. Both APM and ACPI are supported.

Suspend Mode

This item shows the status S1(Stop Clock) when the system enters the power-saving Suspend mode.

Suspend Time Out

This sets the timeout for Suspend mode in minutes. If the time selected passes without any system activity, the computer will enter power-saving Suspend mode.

Resume On RTC Alarm/Date/Hour/Minute/Second

The system can be turned off with a software command. If you enable this item, the system can automatically resume at a fixed time based on the system's RTC (realtime clock). Use the items below this one to set the date and time of the wake-up alarm. You must use an ATX power supply in order to use this feature.

Keyboard Power On

If you enable this item, system can automatically resume by pressing hot key, Power key or any key on the keyboard, or typing in the password. You must use an ATX power supply in order to use this feature.

LAN/Ring Power On

The system can be turned off with a software command. If you enable this item, the system can automatically resume if there is an incoming call on the Modem, or traffic on the network adapter. You must use an ATX power supply in order to use this feature.

PCI / Plug and Play Setup Page

This page sets up some parameters for devices installed on the PCI bus and those utilizing the system plug and play capability.

<i>CMOS SETUP UTILITY - Copyright (C) 1985-2003, American Megatrends, Inc.</i>	
<i>PCI / Plug and Play Setup</i>	
<i>Primary Graphics Adapter PCI</i>	<i>Help Item</i>
<i>Allocate IRQ to PCI VGA Yes</i>	<i>Option</i>
<i>PCI IDE BusMaster Disabled</i>	<i>PCI</i>
	<i>AGP</i>
<i>← → : Move Enter: Select +/-: Value F10: Save Esc: Exit</i>	
<i>F1: General Help F9: Optimized Defaults</i>	

Primary Graphics Adapter

This item indicates if the primary graphics adapter uses the PCI or the AGP bus. The default PCI setting still lets the onboard display work and allows the use of a second display card installed in an AGP slot.

Allocate IRQ to PCI VGA

If this item is enabled, an IRQ will be assigned to the PCI VGA graphics system. You set this value to No to free up an IRQ.

PCI IDE BusMaster

This item enables or disables the DMA under DOS mode. We recommend you to leave this item at the default value.

BIOS Security Features Setup Page

This page helps you install or change a password.

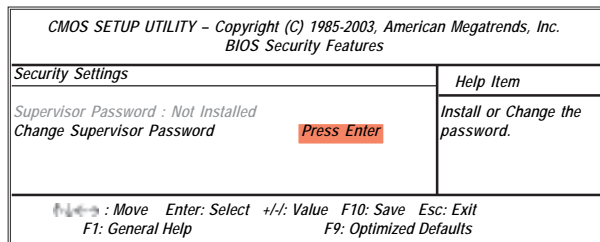

Supervisor Password

This item indicates whether a supervisor password has been set. If the password has been installed, *Installed* displays. If not, *Not Installed* displays.

Change Supervisor Password

You can select this option and press <Enter> to access the sub menu. You can use the sub menu to change the supervisor password.

Motherboard User's Guide

CPU PnP Setup Page

This page helps you manually configure the mainboard for the CPU. The system will automatically detect the type of installed CPU and make the appropriate adjustments to the items on this page.

CMOS SETUP UTILITY - Copyright (C) 1985-2003, American Megatrends, Inc. CPU PnP Setup		
Processor Type : AMD Athlon (tm)		Help Item
CPU Frequency	100	Options
Auto Detect DRAM Clock	Enabled	100
DRAM Frequency	200 MHz	133
		166
←→ : Move Enter: Select +/-: Value F10: Save Esc: Exit F1: General Help F9: Optimized Defaults		

Processor Type

This item shows the type of the CPU installed in your system.

CPU Frequency

This item shows frequency of the CPU installed in your system.

Auto Detect DRAM Clock / DRAM Frequency

When this item is enabled, it automatically detects and shows clock and frequency of the DRAM memory installed in your system; when disabled, it lets users manually adjust clock and frequency of the DRAM memory.

Hardware Monitor Page

This page sets up some parameters for the hardware monitoring function of this motherboard.

CMOS SETUP UTILITY - Copyright (C) 1985-2003, American Megatrends, Inc. Hardware Monitor Setup		
*** System Hardware Monitor***		Help Item
Vcore	1.824V	
Vcc2.5V	2.496V	
Vddq	1.504V	
Vcc5V	5.134V	
SB3V	3.488V	
CPU FAN Speed	5273 RPM	
SYSTEM FAN Speed	0 RPM	
CPU Temperature	53°C/127°F	
SYSTEM Temperature	34°C/93°F	
←→ : Move Enter: Select +/-: Value F10: Save Esc: Exit F1: General Help F9: Optimized Defaults		

CPU/System Temperature

These items display CPU and system temperature measurement.

FANs & Voltage Measurements

These items indicate cooling fan speeds in RPM and the various system voltage measurements.

Load Optimal Defaults

This option opens a dialog box to ask if you are sure to install optimized defaults or not. You select [OK], and then <Enter>, the Setup Utility loads all default values; or select [Cancel], and then <Enter>, the Setup Utility does not load default values.

Note: It is highly recommend that users enter this option to load optimal default values for accessing the best performance.

Save Changes and Exit

Highlight this item and press <Enter> to save the changes that you have made in the Setup Utility configuration. When the Save Changes and Exit dialog box appears, select [OK] to save and exit, or [Cancel] to return to the main menu.

Discard Changes and Exit

Highlight this item and press <Enter> to discard any changes that you have made in the Setup Utility and exit the Setup Utility. When the Discard Changes and Exit dialog box appears, select [OK] to discard changes and exit, or [Cancel] to return to the main menu.

Note: If you have made settings that you do not want to save, use the "Discard Changes and Exit" item and select [OK] to discard any changes you have made.

Chapter 4 Software & Applications

Introduction

This chapter describes the contents of the support CD-ROM that comes with the motherboard package.

The support CD-ROM contains all useful software, necessary drivers and utility programs to properly run our products. More program information is available in a README file, located in the same directory as the software.

To run the support CD, simply insert the CD into your CD-ROM drive. An Auto Setup screen automatically pops out, and then you can go on the auto-installing or manual installation depending on your operating system.

If your operating system is Windows 2000/XP, it will automatically install all the drivers and utilities for your motherboard; if Windows NT or manual installation, please follow the instructions described as the Installing under Windows NT or Manual Installation section.

Installing Support Software

- 1 Insert the support CD-ROM disc in the CD-ROM drive.
- 2 When you insert the CD-ROM disc in the system CD-ROM drive, the CD automatically displays an Auto Setup screen.
- 3 The screen displays three buttons of **Setup**, **Browse CD** and **Exit** on the right side, and three others **Setup**, **Application** and **ReadMe** at the bottom. Please see the following illustration.



The **Setup** button runs the software auto-installing program as explained in next section.

Chapter 4: Software & Applications

The **Browse CD** button is a standard Windows command that you can check the contents of the disc with the Windows 98 file browsing interface.

The **Exit** button closes the Auto Setup window. To run the program again, reinsert the CD-ROM disc in the drive; or click the CD-ROM driver from the Windows Explorer, and click the Setup icon.

The **Application** button brings up a software menu. It shows the bundled software that this mainboard supports.

The **ReadMe** brings you to the Install Path where you can find out path names of software driver.

Auto-Installing under Windows 2000/XP

If you are under Windows 2000/XP, please click the **Setup** button to run the software auto-installing program while the Auto Setup screen pops out after inserting the support CD-ROM:

- 1 The installation program loads and displays the following screen. Click the **Next** button.

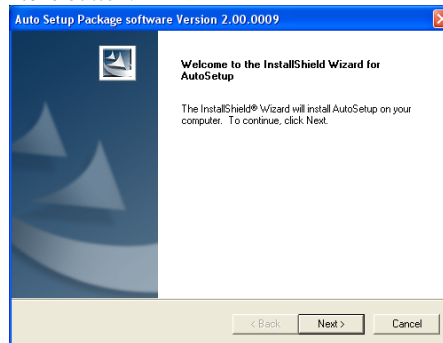

- 2 Select the items that you want to setup by clicking on it (the default options are recommended). Click the **Next** button to proceed.

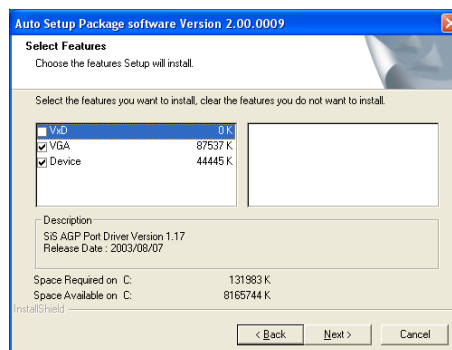

- 3 The support software will automatically install.

Once any of the installation procedures start, software is automatically installed in sequence. You need to follow the onscreen instructions, confirm commands and allow the computer to restart as few times as needed to complete installing whatever software you selected. When the process is finished, all the support software will be installed and start working.

Installing under Windows NT or Manual Installation

If you are under Windows NT, the auto-installing program doesn't work out; or you have to do the manual installation, please follow this procedure while the Auto Setup screen pops out after inserting the support CD-ROM:

- 1 Click the **ReadMe** to bring up a screen, and then click the **Install Path** at the bottom of the screen.
- 2 Find out your mainboard model name and click on it to obtain its correct driver directory.
- 3 Install each software in accordance with the corresponding driver path.

Bundled Software Installation

All bundled software available on the CD-ROM is for users' convenience. You can install bundled software as follows:

- 1 Click the **Application** button while the Auto Setup screen pops out after inserting the support CD-ROM.
- 2 A software menu appears. Click the software you want to install.
- 3 Follow onscreen instructions to install the software program step by step until finished.