



## *Declaration of Conformity*

According to 47 CFR, Parts 2 and 15 of the FCC Rules

The following designated product:

**EQUIPMENT: MAINBOARD  
MODEL NO.: 7AIA**

is a Class B digital device that complies with 47 CFR Parts 2 and 15 of the FCC Rules. Operation is subject to the following two conditions:

1. This device may not cause harmful interference.
2. This device must accept any interference received, including interference that may cause undesired operation.

This declaration is given to the manufacturer:

**CHAINTECH COMPUTER U.S., INC.  
509 Valley Way, Milpitas, CA 95035, U.S.A.**

**Tel: 1-408-935-6988**

**Fax: 1-408-935-6989**

Chaintech President: Simon Ho

Signature:

A handwritten signature in black ink, appearing to be 'Simon Ho', written over a horizontal line.

---

## **Federal Communications Commission Statement**

This device complies with FCC Rules Part 15. Operation is subject to the following two conditions:

- ♦ This device may not cause harmful interference
- ♦ This device must accept any interference received, including interference that may cause undesired operation.

This equipment has been tested and found to comply with the limits for a Class B digital device, pursuant to Part 15 of the FCC Rules. These limits are designed to provide reasonable protection against harmful interference in a residential installation. This equipment generates, uses and can radiate radio frequency energy. If this equipment is not installed and used in accordance with the manufacturer's instructions, it may cause harmful interference to radio communications. However, there is no guarantee that interference will not occur in a particular installation. If this equipment does cause harmful interference to radio or television reception, which can be determined by turning the equipment off and on, the user is encouraged to try to correct the interference by one or more of the following measures:

- ♦ Reorient or relocate the receiving antenna.
- ♦ Increase the separation between the equipment and receiver.
- ♦ Connect the equipment to an outlet on a circuit different from that to which the receiver is connected.
- ♦ Consult the dealer or an experienced radio/TV technician for help.

The use of shielded cables for connection of the monitor to the graphics card is required to assure compliance with FCC regulations. Changes or modifications to this unit not expressly approved by the party responsible for compliance could void the user's authority to operate this equipment.

## **Canadian Department of Communications Statement**

This digital apparatus does not exceed the Class B limits for audio noise emissions from digital apparatuses set out in the Radio Interference Regulations of the Canadian Department of Communications.

## **Manufacturer's Disclaimer Statement**

The information in this document is subject to change without notice and does not represent a commitment on the part of the vendor. No warranty or representation, either expressed or implied, is made with respect to the quality, accuracy or fitness for any particular purpose of this document. The manufacturer reserves the right to make changes to the content of this document and/or the products associated with it at any time without obligation to notify any person or organization of such changes. In no event will the manufacturer be liable for direct, indirect, special, incidental or consequential damages arising out of the use or inability to use this product or documentation, even if advised of the possibility of such damages. This document contains materials protected by copyright. All rights are reserved. No part of this manual may be reproduced or transmitted in any form, by any means or for any purpose without expressed written consent of its authors. Product names appearing in this document are mentioned for identification purposes only. All trademarks, product names or brand names appearing in this document are registered property of their respective owners.

Printed in Taiwan

July 2000  
100% POST-CONSUMER  
RECYCLED PAPER 

---

# **Main Board User's Manual**

---

---

# Table of Contents

<b>Chapter 1 Introduction .....</b>	<b>1</b>
1-1 Product Specifications .....	1
1-2 Product Feature .....	4
1-3 Package Content .....	5
<b>Chapter 2 Hardware Setup .....</b>	<b>7</b>
2-1 Introduction to Jumpers .....	7
2-2 Installing an AMD Athlon Processor in Socket A .....	8
2-3 Plug and Play CPU Configuration.....	8
2-4 Connector and Jumper Settings .....	10
2-5 Main Memory Configuration .....	19
<b>Chapter 3 Award BIOS Setup Program .....</b>	<b>21</b>
3-1 Standard CMOS Features .....	22
3-2 Advanced BIOS Features .....	25
3-3 Advanced Chipset Features.....	28
3-4 Integrated Peripherals .....	31
3-5 Power Management Setup .....	33
3-6 PnP/PCI Configuration .....	36
3-7 PC Health Status.....	37
3-8 Frequency/Voltage Control .....	38
3-9 Load Fail-Safe Defaults.....	39
3-10 Load Optimized Defaults.....	40
3-11 Supervisor Password & User Password Setting .....	41
3-12 Save and Exit Setup .....	42
3-13 Exit Without Saving.....	42
<b>Chapter 4 Brief Software Driver Guide .....</b>	<b>43</b>
<b>Appendices</b>	
Appendix I On Board I/O Addresses & IRQ Maps.....	45
Appendix II Embedded Flash Utility .....	47
<b>Feature Explanations</b>	
Software Power-off Control .....	10
Over-ride Power Button.....	11
Blinking LED in Suspend Mode .....	11
Power On By Modem .....	14/35
Power On By Alarm .....	35
Poly-fuse Over Current Protection .....	12

---

# Chapter 1

## Introduction

### 1-1 Product Specifications

#### ❑ Processor

- Supports AMD Socket A processors up to 950MHz
- 100MHz DDR (Double Data Rate) transfer on K7 CPU address and data buses
- High efficiency switching power modules provides 1.6v for Vcc and up to 42A for Icc

#### ❑ Chipset

- VIA Apollo KT133 (VT8363/686A) two chip AGPset

#### ❑ DRAM Memory

- Two 3.3V 168-pin DIMM sockets support up to 1GB
- Supports PC-100, PC-133 SDRAM, and VCM
- Provides single-bit ECC capability

#### ❑ Expansion Slots

- One 32-bit AGP slot for both 2x/4xAGP at 3.3v or 1.5v (Rev 2.0 compliant)
- Three 32-bit PCI slots (Rev 2.2 compliant)
- One 16-bit ISA slot (with sharing slot)

#### ❑ 2Mb Boot-Block Flash ROM

- Award System BIOS, supports PnP, APM, DMI, ACPI & Multi-device booting features i.e. floppy, LS120, CD-ROM, HDD(IDE, SCSI), ZIP-ATAPI etc.
- Includes Trend **ChipAway Virus** protection for virus-free boot and virus free operating system
- **BIOS Wonder** technology including ChipAway Virus, Flash BIOS Write Protect, Embedded Flash Utility.

#### ❑ Embedded Ultra DMA-66 PCI IDE controller

- Supports two IDE ports up to 4 ATAPI devices
- Supports up to PIO Mode 4 up to 16.6MBps, Multi-Word Mode 4 up to 66MBps with bus mastering
- Bus Master software drivers for all common multi-task operating systems
- Optional VIA 686B ATA-100 support

❑ **Embedded Super I/O Functions**

- Two UARTs support two serial ports and IR function for HPSIR and ASKIR
- One parallel supports SPP/ECP/EPP
- One floppy disk drive connector supports up to 2.88MB, Japanese 3- Mode and 1Mbps transfer rate
- Supports Game/MIDI port for soft-audio

❑ **Double Stack Back-Panel I/O Connectors with PC99 Colored Codes**

- PS/2 Mini-DIN keyboard and mouse ports
- Two Channel USB ports
- Two D-SUB 9-pin male serial port
- One D-SUB 25-pin female Printer port
- One D-SUB 15-pin female Game/MIDI port
- Audio Line-out, Line-in, Mic-in jacks

❑ **Embedded PCI Audio Subsystem**

- CMedia 8738 **audio chip w/ integrated CODEC legacy audio SB16/Pro compatible**
- Programmable independent sample rate from 4KHz to 48KHz for record and playback
- Full-duplex operation for simultaneous recording and playback
- DLS-based wavetable music synthesizer w/ maximum 32 simultaneous notes, supports MS DirectMusic (Wavetable technology licensed from ERSO w/ General MIDI 128 sounds, 8 drum kit)
- 32-voice HRTF 3D positional audio, CRL 3D supports MS DirectSound3D, Aureal A3D and Creative EAX(Environment Audio Extensions) APIs
- Supports 24-bit S/PDIF-in/out for digital audio (for ex. compressed AC3 data)
- 4-Channel speaker audio support is easy to build up a Home Theater environment
- Supports MIDI and dual game ports
- Embedded 32OHM .5w earphone amplifier
- PCI V2.1 compliant and full Legacy DOS software compatible
- Supports Fiber Optic module for Internet music, PC, and MD connections

❑ **Embedded USB Controller**

- USB host controller (UHCI v1.0 compliant) with Root Hub
- Four USB ports with over-current protection
- Optional USB riser with 2 additional USB ports

❑ **Embedded System Monitoring Hardware Subsystem**

- 5 external voltage inputs for CPU Vcore, VDD, +12v, +5v and 3.3v (internal detecting)
- 2 temperature sensor with thermistor for CPU & System
- 2 Fan speed (CPU and System) monitoring

### ❑ Optional Embedded Graphic Accelerator(for 7AIV only)

- Integrated 128-bit S3 Savage4 2D/3D graphics engine
- Floating point triangle setup engine w/ 8 MTps setup engine and 140MPps trilinear fill rate
- Optimized Shared Memory Architecture (SMA) supports 2 to 32MB frame buffer using system memory
- Supports AGP 4x, including sideband addressing and execute mode
- Supports up to 1920x1440 resolution
- Motion Video compensation for full speed DVD playback
- With TV encoder or TMDS Transmitter, to support DFP monitor and NTSC/PALTV
- Supports 12-bit digital interface with up to 1280x1024 resolution DFP

### ❑ Board Dimensions

- Micro ATX form factor, 244mm x 220mm, 4 Layers

### ❑ Switching Power Supply Requirement

Output Voltage	Max. Regulation Requirement	Min. Current Requirement (Amps)
+12V	+/- 5%	5.5
+5V	+/- 5%	20
+3.3V	+/- 5%	15
-5V	+/- 10%	0.5
-12V	+/- 10%	0.5
<b>+5VSB</b>	<b>+/- 5%</b>	<b>0.75</b>

**Table 1-1**



3.3Vat 15Amps is necessary to guarantee full loading operation because some AGP cards and memory modules have high current consumption.

## 1-2 Product Feature

- Poly-fuse over-current protection with error warning for keyboard circuitry
- Complete Data Security:
  - \* **Flash BIOS write protection** against unauthorized access
  - \* **Trend ChipAway Virus** for a 100% virus free system boot-up
  - \* **Embbded Flash Utility** ease the upgrade way and solve the incompatibility between flash type and flash utility
- Advanced Management Features:
  - \* Power-on events:
    - WOL(Wake-on-LAN) network card, Modem ring, RTC Alarm
  - \* Software power-off control for Win95
  - \* Over-ride power button
  - \* Three states advanced Power-failure recovery: Always On, Always Off, Last state
  - \* Chassis intrusion detection with mnemonics during power loss
  - \* Blinking Power-LED in suspend



## 1-3 Package Contents

This product comes with the following components:

- One mainboard
- One 40-pin Ultra DMA-66 IDE connector ribbon cable (Figure 1-1)
  - \* **Color coded connection for UDMA/66 cable**
    - Blue to mainboard, Gray to Master and Black to slave
- One 34-pin floppy disk drive ribbon cable (Figure 1-2)
- One User's Manual
- One CD-ROM that includes
  - Acrobat Reader
  - Award Flash EPROM Utility
  - Award DMI Utility for DOS
  - VIA Service Pack for Win9x/WinNT including Bus Master IDE drivers, AGP VxD and etc.
  - VIA Sound Driver for DOS/Win95/98/NT
  - S3 AGP Driver for Win95/98/NT
  - CMedia audio drivers for Win3.1, Win95/98/2000, NT4.0 and Linux
  - CMedia Multimedia Decks
  - Optional **Value Pack 2000** software group including Shepherd2000, Trend PC-cillin, Norton AntiVirus, ADOBE ActiveShare, Appio and X-stop



**Figure 1-1** UDMA66 IDE cable



**Figure 1-2** Standard Floppy cable

# ***Memo***

## Chapter 2

# Hardware Setup

If your mainboard has already been installed in your computer you may still need to refer to this chapter if you plan to upgrade your system's hardware.

**! Be sure to disconnect the power cable from the power source before performing any work on your mainboard, i. e. installing a CPU, memory module, changing a jumper setting, etc. Not doing so may result in electrical shock!**

## 2-1 Introduction to Jumpers

Jumpers are used to select between various operating modes. A jumper consists of a row of gold colored pins that protrude from the surface of the mainboard. It is important not to confuse jumpers with connectors or headers.

**! Putting jumper caps on anything that is not a jumper may result in damaging your mainboard. Please refer to Section 1-3, Mainboard Layout, for the location of jumpers on your mainboard.**

As indicated in Figure 2-1 below, a cap is used to cover the pins of a jumper, resulting in shorting those pins that it covers. If the cap is removed from the top of the pins, the jumper is left "open." The number 1 shown both in the diagram below and in all multiple pin jumper and header diagrams in this manual indicates the pin designated with the number 1. The numbering of the remaining pins follows in sequence.

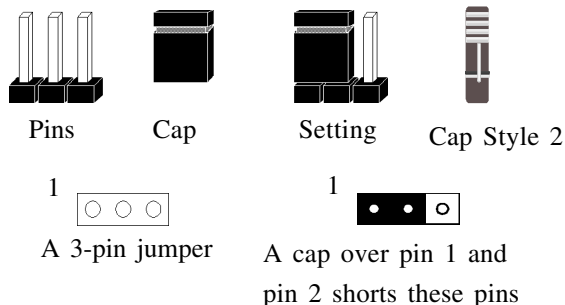

Figure 2-1

## 2-2 Installing an AMD Athlon Processor in Socket A

1. The Socket 462, designed for AMD Athlon processors, has been incorporated as a standard mainboard specification. To insert your CPU into Socket A please do the following:
2. Locate a small dot marked on the top surface of the CPU close to one of its corners. The same corner will also be cut off, leaving a noticeable notch in the CPU's corner. These markings indicate Pin 1 of the CPU.
3. Pull up the lever of Socket 462 so that it is perpendicular with the surface of the mainboard. Gently insert the CPU with Pin 1 at the same corner of Socket 462 that contains the end of the lever. Allow the weight of the CPU to push itself into place. Do not apply extra pressure as doing so may result in damaging your CPU. Snap the lever back into place.



Installing a heat sink with cooling fan is necessary for proper heat dissipation from your CPU. Failing to install these items may result in overheating and possible burnout of your CPU.

## 2-3 Plug and Play CPU Configuration

This board supports plug and play CPU configuration, if you install a CPU on this mainboard, the board will automatically detect and set the CPU system bus frequency speed. It is no longer necessary to make many jumper settings as on conventional mainboards.

### CPU Host/PCI Clock Timing

1. After installing all your hardware into your PC system, turn on your system's power. Enter the CMOS Setup Utility by pressing the Delete key when your BIOS identification screen appears.
2. Move the cursor to Frequency/Voltage Control Setup menu and press Enter. Select the CPU Host/PCI Clock Setup commands at the left hand side of the BIOS screen.
3. Select the CPU Host/PCI Clock value according to the speed of your CPU processor and PCI bus. (See section 3-8)
4. Press Esc to return to the CMOS Setup Utility, press F10 to Save and Exit Setup and choose to confirm. The system will automatically reboot and during start-up you will see the correct CPU type shown on the screen.



You do not need to make frequency ratio and voltage settings because this board will automatically set your CPU frequency ratio & voltage.

Back Panel I/O Connector

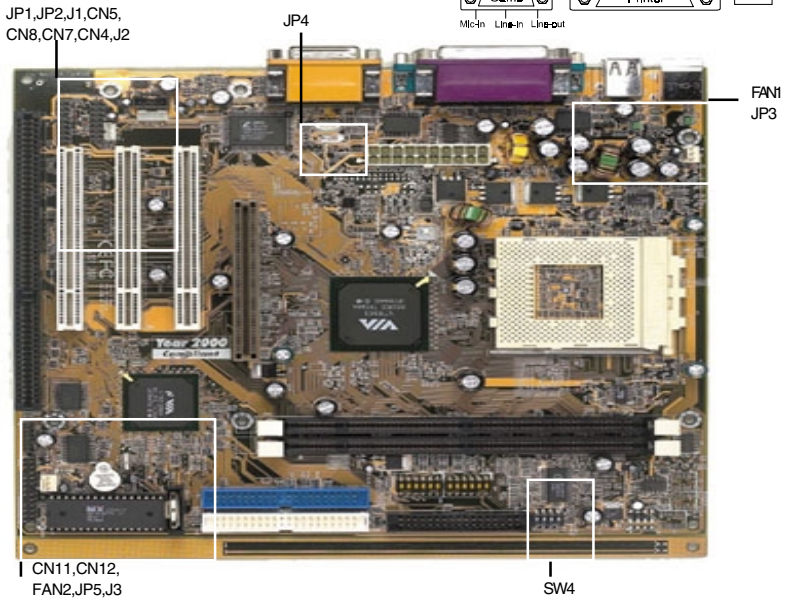

Jumper & Connector No.	Function	Page
JP1	Onboard Modem	13
JP2	Onboard Audio	13
JP3	Optional USB Device Power On Function	13
JP4	Power On By Modem	14
JP5	Clear CMOS data jumper	14
J1	S/PDIF-Out Connector	14
J2	Infrared Connector	15
J3	Chassis Intrusion Detection	15
CN4	CD-ROM Audio in Connector	15
CN5	Optional Modem Telephony Connector	16
CN6	ATX Power Supply Connector	10
CN7	Auxiliary CD-ROM Audio-in Connector	16
CN8	WOL (Wake-on-LAN) Connector	16
CN11	I2C and USB 2/3Connector	17
USB1	USB 0/1 Ports	17
CN12	Over-ride Power Button Connector	11
	Power Indicator LED Connector	11
	Green Switch/Green LED Connector	12
	System Reset Switch Connecto	12
	Speaker Connector	12
	IDE Activity LED Connector	12
	Turbo LED Connector	12
FAN1/FAN2	CPU/System Cooling Fan Connectors	17
SW4	CPU Bus Frequency	18
Port	PS/2 Mouse and Keyboard Ports	18

## 2-4 Connector and Jumper Settings

Connectors are used to link the system board with other parts of the system, including the power supply, the keyboard, and the various controllers on the front panel of the system case.



**The power supply connector is the last connection to be made while installing a mainboard. Before connecting the power supply, please make sure it is not connected to the power source.**

### ATX Power Supply Connector (CN6)

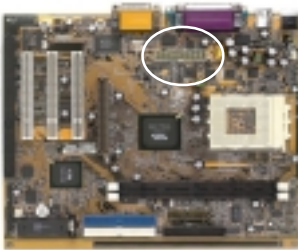

The power cord leading from the system's power supply to the external power source must be the very last part connected when assembling a system.

12V	Ⓔ	Ⓐ	5V
5VSB	Ⓓ	Ⓘ	5V
PW-OK	Ⓔ	Ⓘ	-5V
Ground	Ⓙ	Ⓛ	Ground
5V	Ⓒ	Ⓛ	Ground
Ground	Ⓔ	Ⓛ	Ground
5V	Ⓓ	Ⓛ	PS-ON
Ground	Ⓕ	Ⓛ	Ground
3.3V	Ⓗ	Ⓛ	-12V
3.3V	Ⓘ	Ⓛ	3.3V

The ATX power supply provides a single 20-pin connector interface which incorporates standard +/-5V, +/-12V, optional 3.3V and Soft-power signals. The Soft-power signal, a 5V trickle supply is continuously supplied when AC power is available. When the system is in the Soft-Off mode, this trickle supply maintains the system in it's minimum power state.

### Software Power-Off Control

This mainboard can be powered down using the Windows 95/98 Software Power-Off function. To power down your computer, click the START button on the Windows 95 task bar. Select "Shut Down The Computer" and the system turns off. The message "It is now safe to turn off your computer" will not be shown when using this function.

## Front Panel Connector Set (CN12) A through G

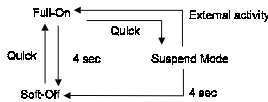
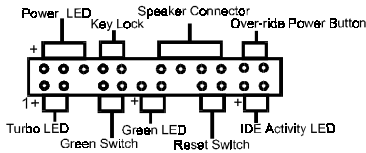
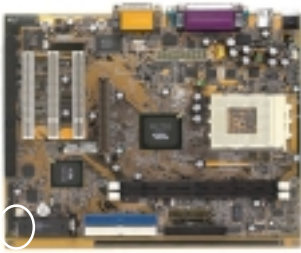

**Over-ride Power Button Operation**

	Pin	Definition
Power Indicator LED	1	+5V DC
	2	No Connection
	3	Ground
Keyboard Lock	4	Key Lock
	5	Ground

### A. Over-ride Power Button Connector

The power button on the ATX chassis can be used as a normal power switch as well as a device to activate Advanced Power Management Suspend mode. This mode is used for saving electricity when the computer is not in use for long periods of time. The Soft-OFF by PWR-BTTN function in BIOS's Power Management Setup menu must be set to "Delay 4 Sec." to activate this function. (See section 3-5)

When the Soft-OFF by PWR-BTTN function is enabled, pushing the power button rapidly will switch the system to Suspend mode. Any occurrence of external activities such as pressing a key on the keyboard or moving the mouse will bring the system back to Full-On. Pushing the button while in Full-On mode for more than 4 seconds will switch the system completely off. See Over-ride Power Button Operation diagram.

### B. Power Indicator LED Connector

The power indicator LED shows the system's power status. It is important to pay attention to the correct cables and pin orientation (i.e., not to reverse the order of these two connectors.)

## Blinking LED in Suspend Mode

While in Suspend mode, the LED light on the front panel of your computer will flash. Suspend mode is entered by pressing the Override Power Button, pushing the Green button on your ATX case, or enabling the Power Management and Suspend Mode options in BIOS's Power Management menu. (See section 3-4)

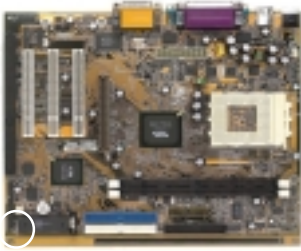

### C. Green Switch/Green LED Connector

Some ATX cases provide a Green switch which is used to put the system in Suspend mode. In Suspend mode, the power supply to the system is reduced to a trickle, the CPU clock is stopped, and the CPU core is in its minimum power state. The system is waken up whenever the keyboard or mouse is touched. The system resumes in different ways as defined by Power Management Setup screen in BIOS.

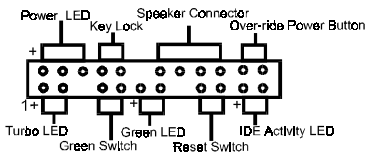

### D. System Reset Switch Connector

This connector should be connected to the reset switch on the front panel of the system case. The reset switch allows you to restart the system without turning the power off.

Pin	Definition
1	System
2	GND

### E. Speaker Connector

Pin	Definition
1	Speaker Signal
2	No Connection
3	No Connection
4	+5V DC

### F. IDE Activity LED Connector

The IDE activity LED lights up whenever the system reads/writes to the IDE devices.

### G. Turbo LED Connector

This mainboard does not have a Turbo/De-turbo speed modes. So the turbo LED will always light .

## Poly-fuse Over Current Protection

The poly-fuse protects the system from dangerous voltages the system might be exposed to via the keyboard or USB connectors. In case of such exposure, the poly-fuse will immediately be disconnected from the circuit, just like a normal fuse. After being disconnected for a certain period of time, the poly-fuse will return to its normal state, after which the keyboard or USB can function properly again. Unlike conventional fuses, the poly-fuse does not have to be replaced, relieving the user wasted time and inconvenience.



## Optional Onboard Modem (JP1)



1  Disable (default)

1  Enable

This function allows you to enable and disable the onboard modem. You must set the jumper's cap to pins 1-2 to enable or set pins 2-3 to disable this function.

## Onboard Audio (JP2)

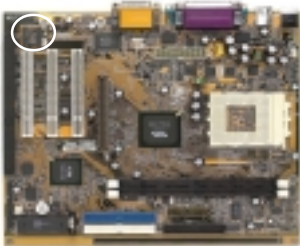

1  Enable (default)

1  Disable

This function allows you to enable and disable the onboard audio. You must set the jumper's cap to pins 1-2 to enable or set pins 2-3 to disable this function.

## Optional USB Device Power On Function (JP3)

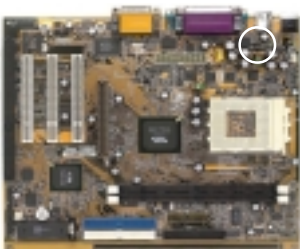

1  Disable (default)

1  Enable

This board is able to be turned on by a USB keyboard (hot key/Password) or a USB mouse click. To use this function, select a device of your choice at the Power on Function option in BIOS's Integrated Peripherals screen. You must also set this jumper's cap to pins 2-3 to use this function.

### Optional Power On By Modem (JP4)

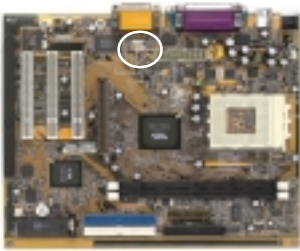

- 1  Disble (default)
- 1  Enable

While in Soft-off state, if thel modem ring-up signal occurs, the system wakes up and can be remotely accessed. You may enable this function by setting the jumper's cap to pin 2-3.

### Clear CMOS Data Jumper (JP5)

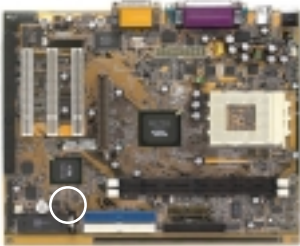

- 1  Normal (default)
- 1  Clear CMOS Data

To clear the contents of the CMOS, please follow the steps below.

1. Disconnect the system power supply from the power source.
2. Set the jumper cap at location 2~3 for 5 seconds, then set it back to the default position.
3. Connect the system's power and then start the system.
4. Enter BIOS's CMOS Setup Utility and choose Load Setup Defaults. Type Y and press enter.
5. Set the system configuration in the Standard CMOS Setup menu.

### Optional S/PDIF-Out Connector (J1)

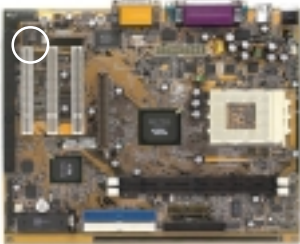

The S/PDIF-Out connector supports the digital audio. This connector must be connected to the cable from an external device. (Ex. 2-channel decoded AC-3 from DVD decoders)

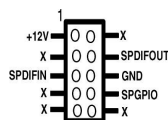

## Infrared Connector (J2)

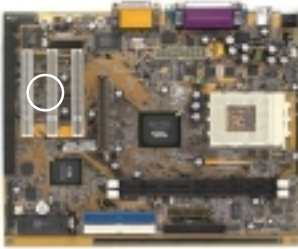

If you enable the UART 2 Mode in BIOS's Integrated Peripherals menu the COM2 port will support IR functions. (See section 3-4)

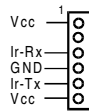

## Chassis Intrusion Detection (J3)

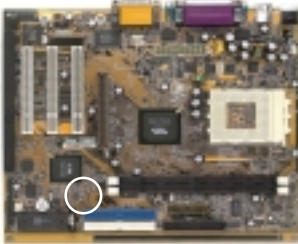

This board supports the chassis instruction monitoring feature of the management extension hardware by means of a mechanical or photo sensor switch attached to the motherboard through this 1x3-pin chassis security header. The mechanical switch is set to open for normal computer operation.

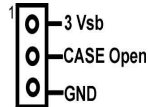

## CD-ROM Audio in Connector (CN4)

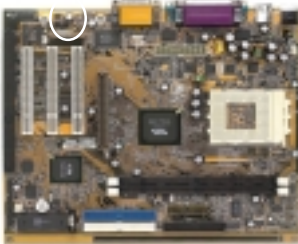

Use the audio cable enclosed with your CD-ROM disk drive to connect the CD-ROM to your mainboard. This will enable your CD-ROM's audio function.

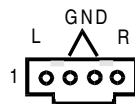

### Optional Modem Telephony Connector (CN5)

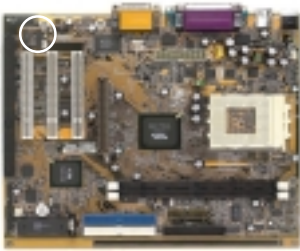

This connector must be connected to the cable from the voice modem card to support modem audio signals.

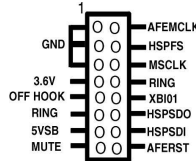

### Auxiliary CD-ROM Audio-in Connector (CN7)

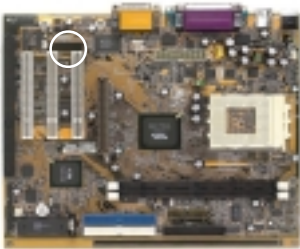

Use the auxiliary audio cable enclosed with your CD-ROM disk drive to connect the CD-ROM to your mainboard. This will enable your CD-ROM's audio function.

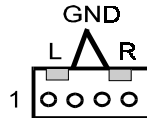

### WOL (Wake-on-LAN) Connector (CN8)

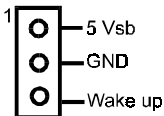

Enable the Wake Up On LAN selection in BIOS's Power Management Menu to use this function. The capability to remotely manage PCs on a network is a significant factor in reducing administrative and ownership costs. Magic Packet technology is designed to give WOL (Wake-on-LAN) capability to the LAN controller. When a PC capable of receiving wake up command goes to sleep, the Magic Packet mode in the LAN controller is enabled. When the LAN controller receives a Magic Packet frame, the LAN controller will wake up the PC. This header is used to connect an add-in NIC (Network Interface Card) which gives WOL capability to the mainboard.

⚠ To support this function, a switching power supply with a minimum of **750mA** 5VSB standby signal is required.

### I<sup>2</sup>C and USB 2/3 Connector (CN11)

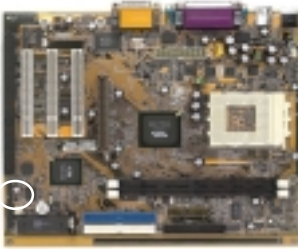

The I<sup>2</sup>C Connector supports the MPEG sound decoder. This connector must be connected to the cable from the MPEG card. This board also contains a connector for optional USB Adaptor (USB2/3). Four USB peripherals or hub devices are able to be connected.

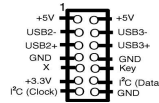

### USB 0/1 Ports (USB1)

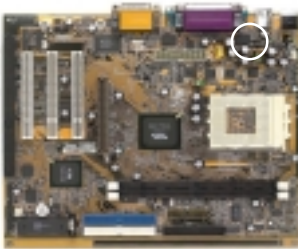

If you want to use a USB keyboard, you must enable the onchip USB & USB keyboard support function in BIOS's Integrated Peripherals menu (See Section 3-4). USB is an open industry standard, providing a simple and inexpensive way to connect up to 125 devices to a single computer port. Keyboards, mice, tablets, digitizers, scanners, bar-code readers, modems, printers and many more can all be used at the same time.

USB is a dynamically reconfigurable serial bus with an elementary data rate of 12Mbps. Based on off the shelf, low cost micro-controller technology, its modular layered software protocol supports sophisticated devices and application programs.

### CPU/System Cooling Fan Connectors (FAN1/FAN2)

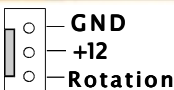
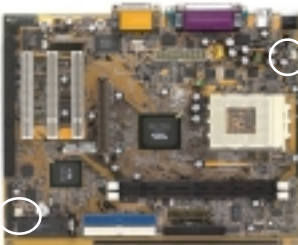

These added connectors allow the fan to draw their power from the mainboard instead of the disk drive connector.

The board's management extension hardware is able to detect the CPU and system fan speed in rpm (revolutions per minute). These connectors supports 3-pin cooling fans with minimum of 3500 RPM. The wiring and plug may vary depending on the manufacturer. On standard fans, the red is positive (+12V), the black is ground, and the yellow wire is the rotation signal.

### CPU Bus Frequency (SW4)



This switch allows you to select between 100MHz FSB or 133MHz FSB frequency speed.

SW4	1	2	3	4
100MHz	OFF	ON	OFF	OFF
133MHz	OFF	OFF	ON	OFF

### Default Dip Switches (SW1/SW2)

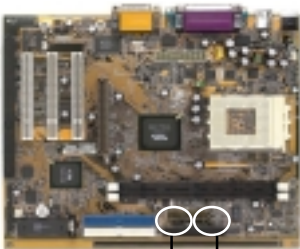

SW2 SW1

SW1	1	2	3	4	5	6
Default	ON	OFF	OFF	ON	ON	OFF

SW2	1	2	3	4	5	6
Default	ON	ON	ON	ON	OFF	OFF

**Note:** SW1& SW2 are factory reserved. Don't change the default setting.

### PS/2 Mouse and Keyboard Ports



If a PS/2 mouse is used, BIOS will automatically detect and assign IRQ12 to the PS/2 mouse.



Pin	Definition
1	Data
2	No Connection
3	Ground
4	+ 5V (fused)
5	Clock
6	No Connection

## 2-5 Main Memory Configuration

The DRAM memory system consists of two banks and the memory size ranges from **16~1GBytes**. It does not matter which bank you want to install first.

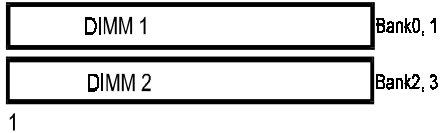

### *DRAM Specifications*

DIMM type: 3.3V, unbuffered, registered, 64/72-bit SDRAM with SPD\*  
Module size: Single/double-side 16/32/64/128/256/512MBytes  
Parity: Either parity or non-parity



This mainboard supports 3.3v, unbuffered, 4-clock, SDRAM DIMM only. Buffered, 5V, or 2-clock SDRAM DIMMs should not be used.



Due to loading anomalies, using DIMM with an 'n x 4' DRAM base on this mainboard is not recommended. For example, a DIMM that uses sixteen 16Mb x 4 devices should not be used.



# *Memo*



## Chapter 3

# Award BIOS Setup Program

Award's BIOS ROM has a built-in setup program that allows users to modify the basic system configuration. This information is stored in CMOS RAM so that it can retain the setup information, even when the power is turned off.

When you turn on or restart the system, press the Delete key to enter the Award BIOS setup program. The primary screen as shown in Figure 3-1 is a list of the menus and functions available in the setup program. Select the desired item and press enter to make changes. Operating commands are located at the bottom of this and all other BIOS screens. When a field is highlighted, on-line help information is displayed on the right side of the screen.

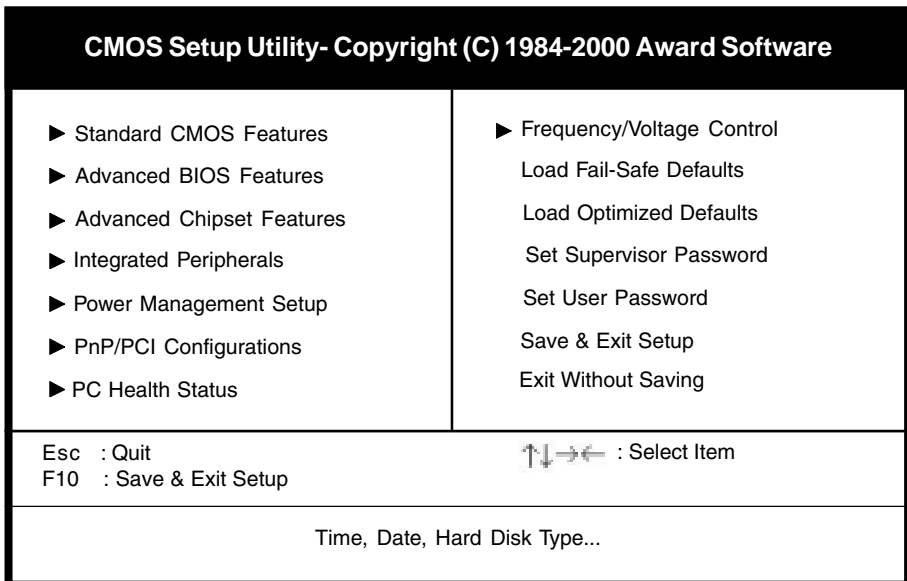

**Figure 3-1 Setup Program Initial Screen**

### 3-1 Standard CMOS Features

The Standard CMOS Features allows users to configure system components such as hard disk drive, floppy disk drive and video display as well as date, time and boot up error signaling. This configuration menu should be changed when installing a mainboard for the first time, changing hardware in your system such as the HDD, FDD, video display, or when the CMOS data has been lost or contaminated. Choose the Standard CMOS Setup option from the CMOS Setup Utility menu (Figure 3-1) to display the following screen. When a field is highlighted, on-line help information is displayed on the left bottom edge of the screen.

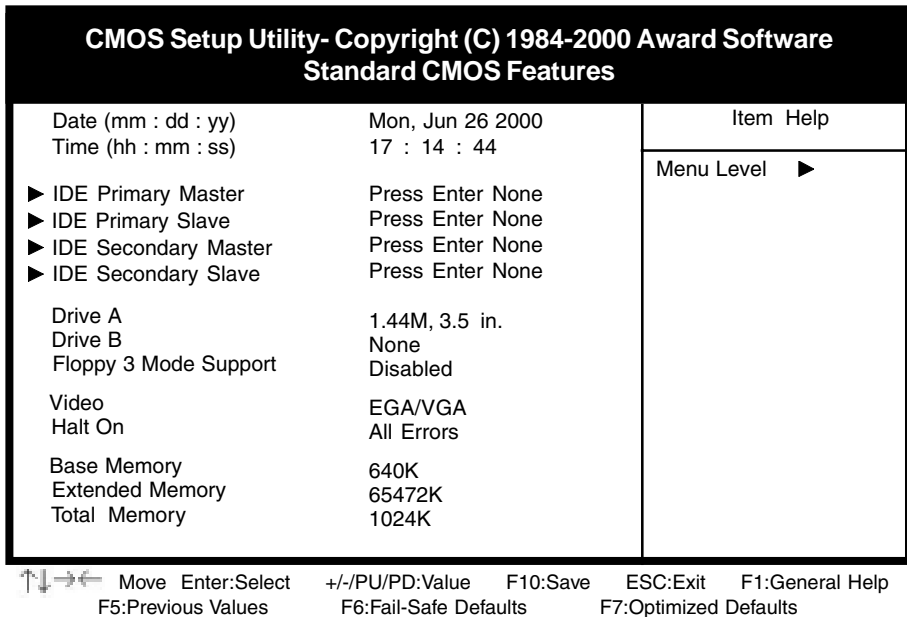

Figure 3-2 Standard CMOS Features Screen

#### Date/Time

Set the date and time. Do not skip this function as all of your timed events such as power management, saving files, etc. are based on this timer.

#### Hard Disk Setup (Primary/Secondary; Master/Slave)

This category identifies up to four IDE hard disk drives that have been installed in the computer. This section does not show information on other IDE devices such as CD-ROM drives or other hard drive types such as SCSI drives.

**Type (Auto/User/None):** Use the fields under the Type column to determine the method you will use to configure the IDE devices. If you choose Auto, BIOS will automatically detect and make optimal settings for most IDE hard drives.



The mainboard manufacturer recommends that you choose Auto for all drives.

Choose User to define your own drive type manually. You must enter values indicated in the table below into each drive parameter field. This information should be included in the documentation from your hard disk vendor or system manufacturer:

TYPE	Setting method
CYLS	Number of cylinders
HEAD	Number of heads
PRECOMP	Write precompensation cylinder
LANDZ	Landing zone
SECTOR	Number of sectors
MODE	Mode type

**Table 3-1 Hard Disk Drive Parameters**

**Cyls/Head/Sector:** The number of Cylinders, Heads, and Sectors can usually be found written on the top of the hard disk. If you have a relatively new hard drive, entering this information alone is usually sufficient for normal hard disk operation. The hard disk will not work properly if you enter improper information for these categories.

**Precomp:** Older hard drives (i.e., MFM or RLL drives) have the same number of sectors per track at the innermost tracks as at the outermost tracks. Thus, the data density at the innermost tracks is higher and the bits are lying closer together. Even though the physical size of a sector gets progressively smaller as the track diameter diminishes, each sector must still hold 512 bytes. Write precompensation circuitry compensates for the difference in sector size by boosting the write current for inner track sectors.

**Landz:** This defines the address of the landing zone and is only used for older hard drives which do not have an auto-parking feature.

**Mode:** If the Type value is not None for any device, you must set the Mode value for that device. There are four different Mode values: Auto, Normal, Large, and LBA.

\* **Auto** - BIOS detects and enters the IDE drive type during boot up.

\* **Normal** - for IDE drives that meet the old IDE specification which support a maximum capacity of 528MB (1024 cylinders, 16 heads, and 63 sectors).

\* **Large** - for IDE drives that do not support LBA and have more than 1024 cylinders. Try this setting if your hard disk does not operate properly with the LBA setting. Large mode is not supported by all operating systems, i.e., only certain versions of DOS support large mode.

\* **LBA** - (Large/Logical Block Addressing) With LBA, the IDE controller transforms the data address described by sector, head, and cylinder number into a physical block address, significantly improving data transfer rates. This mode is for drives with greater than 1024 cylinders and between 528MB and 8.4GB in size. This protocol is the current common standard.

Choose None for Type if there are no IDE HDD devices in your system.

- ✎ You can use the IDE HDD Auto Detection function to auto detect your hard drive parameters. Using this function will automatically insert the parameters discussed under Hard Disk Setup and will indicate User for the Field value. Please see Section 3-9 for more information.

### **Floppy Disk Drives**

Choose the memory capacity and disk size that corresponds with that of your floppy disk drive(s).

### **Video**

Select the type of video adapter present in your system. You can ignore this setting if you are using a VGA monitor since VGA BIOS automatically configures this setting.

### **Halt**

When the system is powered on, BIOS performs a series of diagnosis tests called POST (Power On Self Test). This function stops the computer if BIOS detects a hardware error. You can tell BIOS to halt on all errors, no errors, or not to halt on specific errors.

## 3-2 Advanced BIOS Features

By choosing the Advanced BIOS Features option from the CMOS Setup Utility menu (Figure 3-1), the screen below is displayed. This sample screen contains the manufacturer's default values for the mainboard.

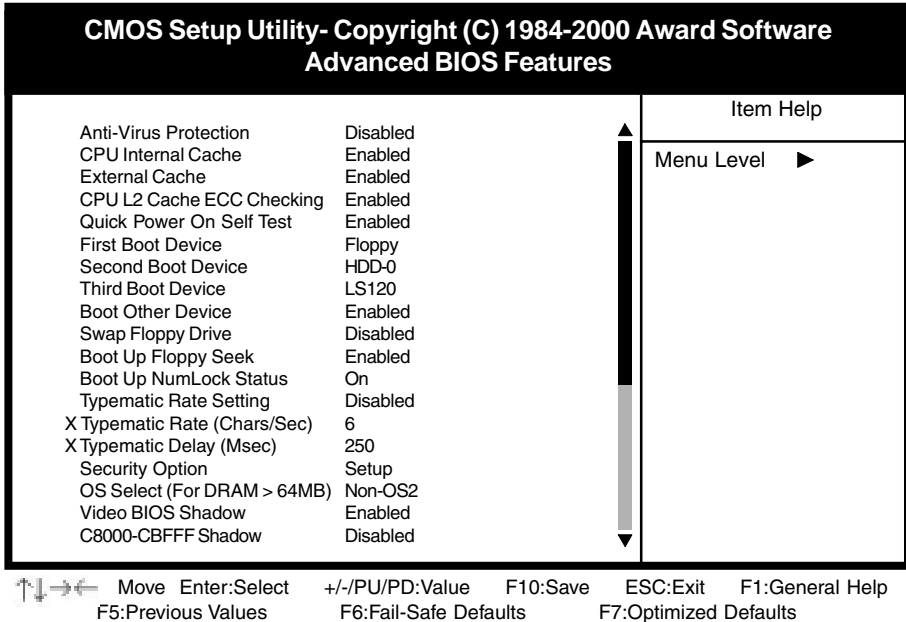

Figure 3-3 Advanced BIOS Features Screen

### A. Anti-Virus Protection

#### Trend ChipAway Virus

Trend ChipAway Virus is a code incorporated in the mainboard's BIOS firmware. During the boot-up sequence, BIOS loads before loading of the partition table or boot sector. ChipAway Virus loads with BIOS and is able to detect boot-up viruses before they have a chance to infect the hard drive. ChipAway Virus employs rule-based logic that doesn't look for specific viruses but rather detects patterns found in every virus, eliminating the need to perform periodical version updates after new viruses have been found.

## **B. Cache Control**

### **CPU Internal Cache/External Cache**

Cache memory is much faster than conventional DRAM system memory. These fields allow you to enable or disable the CPUs Level 1 built-in cache and Level 2 external cache. Both settings are left enabled to significantly increase the performance of your computer.

## **C. Boot Up Features**

After turning on the system, BIOS will perform a series of device initialization and diagnostic tests discussed below.

### **Quick Power On Self Test (POST)**

Enable this function to reduce the amount of time required to run the POST (Power On Self Test). BIOS saves time by skipping some items during POST. It is recommended that you disable this setting. Discovering a problem during boot up is better than losing data during your work.

### **First/Second/Third/Boot Other Device**

This option sets the sequence of drives BIOS attempts to boot from after POST completes. BIOS will search these drives for an operating system.

### **Swap Floppy Drive**

Enabling this function will swap the floppy drive assignment so that drive A will function as drive B, and drive B will function as drive A. Note that the boot sequence assignment mentioned directly above does not include booting from floppy drive B. This function is useful if floppy drives B and A are of a different format and you want to boot from floppy drive B.

### **Boot up Floppy Seek**

During POST, BIOS will determine if the installed floppy disk drive has 40 or 80 tracks. A 360K drive has 40 tracks and 720K, 1.2M and 1.44M drives have 80 tracks. All modern floppy disk drives have 80 tracks.

### **Boot Up NumLock Status**

This function defines the keyboard's number pad as number keys or arrow keys.

## **D. Keyboard Interface**

### **Typematic Rate Setting**

When enabled, you can set the following two typematic control items. When disabled, keystrokes are determined arbitrarily by the keyboard controller in your system.

### **Typematic Rate (Chars/Sec)**

The typematic rate sets the rate at which characters on the screen repeat when a key is pressed and held down.

### **Typematic Delay (Msec)**

The typematic delay sets how long after you press a key that a character begins repeating.

### **E. Security Option**

The Supervisor and/or User Password functions shown in Figure 3-1 must be set to take advantage of this function. See Section 3-11 for password setting information. When the Security Option is set to System, a password must be entered to boot the system or enter the BIOS setup program. When the Security Option is set to Setup, a password is required to enter the BIOS setup program.

### **F. OS Select (For DRAM >64MB)**

If your system's DRAM is larger than 64MB and you are running OS/2, select OS/2 as the item value. Otherwise, set the item value to Non-OS/2 for all other operating systems.

### **G. Shadow Memory**

Software such as system BIOS, video BIOS, SCSI BIOS, etc that resides in ROM (Read Only Memory) chips is called firmware. Shadowing of firmware occurs when BIOS is copied to RAM address C0000h through DFFFFh. Video BIOS loads into the C0000-C7FFF memory area when video shadowing is enabled. If an expansion peripheral in your system contains ROM-based firmware, you need to know the address range the ROM occupies to shadow it into the correct area of RAM.

Shadowing improves the firmware's performance because the firmware can be read by the CPU through the 16- or 32-bit DRAM bus as opposed to the 8-bit XT bus. However, shadowing also results in reducing the amount of high memory (640 KB to 1 MB) for loading device drivers. Shadowing is used mostly for ROM chips on ISA cards and not for PCI cards. Shadowing and playing games at the same time may result in system instability as some games access the RAM memory area being shadowed.

### 3-3 Advanced Chipset Features

By choosing the Advanced Chipset Features option from the CMOS Setup Utility menu (Figure 3-1), the screen below is displayed. This sample screen contains the manufacturer's default values for the mainboard.

**CMOS Setup Utility- Copyright (C) 1984-2000 Award Software**  
**Advanced Chipset Features**

Bank 0/1 DRAM Timing	Normal		Item Help
Bank 2/3 DRAM Timing	Normal		Menu Level ▶
SDRAM Cycle Length	Auto		
DRAM Clock	Host CLK		
Memory Hole	Disabled		
P2C/C2P Concurrency	Enabled		
Fast R-W Turn Around	Disabled		
System BIOS Cacheable	Disabled		
Video RAM Cacheable	Disabled		
AGP Aperture Size	64M		
AGP-4X Mode	Enabled		
AGP Driving Control	Auto		
AGP Driving Value	DA		
AGP Fast Write	Disabled		
K7 CLK_CTL Select	Optimal		
Flash BIOS Protection	Disabled		
CPU to PCI Write Buffer	Enabled		
PCI Dynamic Bursting	Enabled		

↑↓→← Move  
 Enter:Select  
 +/-/PU/PD:Value  
 F10:Save  
 ESC:Exit  
 F1:General Help  
F5:Previous Values  
 F6:Fail-Safe Defaults  
 F7:Optimized Defaults

**Figure 3-4 Chipset Features Setup Screen**



All of the above settings have been determined by the mainboard manufacturer and should not be changed unless you are absolutely sure of what you are doing. Explanation of the DRAM timing and chipset features setup is lengthy, highly technical and beyond the scope of this manual. Below are abbreviated descriptions of the functions in this setup menu. You can look on the world wide web for helpful chipset and RAM configuration information including AWARD's web site at <http://www.award.com>.

#### **A. BANK 0/1 and 2/3 DRAM Timing**

This item allows you to select the value in this field, depending on whether the board has pagged DRAM or EDO (Extended Data Output) DRAMs.

#### **B. SDRAM Cycle Length**

When synchronous DRAM is installed, the number of the clock cycles of CAS latency depends on the DRAM timing. Do not reset this setting from the default value specified by the system designer.



### **C. Memory Hole at 15M-16M**

Enabling this function will reserve the memory address space between 15MB and 16MB for ISA expansion cards. However, enabling this function will result in not allowing the system to have access to memory above 16MB. Please note that some expansion cards require this setting to be enabled. The default setting is Disabled. If Auto Configuration is enabled, you must set the DRAM timing function to 60ns or 70ns, depending on the type of DRAM you install.

### **D. System BIOS Cacheable**

Enabling this function allows caching of the system BIOS ROM at F0000h-FFFFFh, resulting in better system performance. However, if any program writes to this memory area, a system error may result. Caching the system BIOS results in better performance than shadowing the system BIOS as discussed in Section 3-2.

### **E. Video RAM Cacheable**

Enabling this function will allow caching of the video RAM, resulting in better system performance. However, if any programs write to this memory area, a system error may occur.

### **F. AGP Aperture Size**

This function determines the amount of system memory that is given to the AGP card. Options range from 4MB to 128MB. This is a dynamic memory allotment in that the AGP card will only use the amount of memory that it needs. The remaining memory not in use will be available for the system to use. For example, if 16MB is allotted to the AGP card and the card only needs 8MB, the remaining 8MB will be available for system use.

### **G. AGP-4X Mode**

Enable this setting to utilize the 4X mode (twice as fast as 2X) offered by advanced AGP cards. Your VGA card must support 4X mode in order to take advantage of the faster speed.

### **H. Flash BIOS Protection**

The mainboard manufacturer developed BIOS protection technology that protects the System BIOS from accidental corruption by unauthorized users or computer viruses. When enabled, the BIOS data cannot be changed when attempting to update BIOS with the the FLASH utility. When disabled, the BIOS data can be updated by using the FLASH utility.

***I. Hardware Reset Protect***

When this function is enabled, your PC's hardware reset button will not function. This function is especially useful to prevent accidental resets for file servers and routers, etc., which should be available 24 hrs/day. When disabled, your PC's hardware reset button will function normally.

***J. CPU to PCI Write Buffer***

When Enabled, CPU to the PCI bus are buffered, to compensate for the speed differences between the CPU and the PCI bus.

***K. PCI Delay Transaction***

The chipset has an embedded 32-bit posted write buffer to support delay transactions cycles. Select Enabled to support compliance with PCI specification version 2.1.

***L. Memory Parity/ECC Check***

If the DRAM chips in your system support parity/ECC check, select Enabled

## 3-4 Integrated Peripherals

This section provides information on setting peripheral devices. By choosing the Integrated Peripherals option from the CMOS Setup Utility menu (Figure 3-1), the screen below is displayed. This sample screen contains the manufacturer's default values for the mainboard.

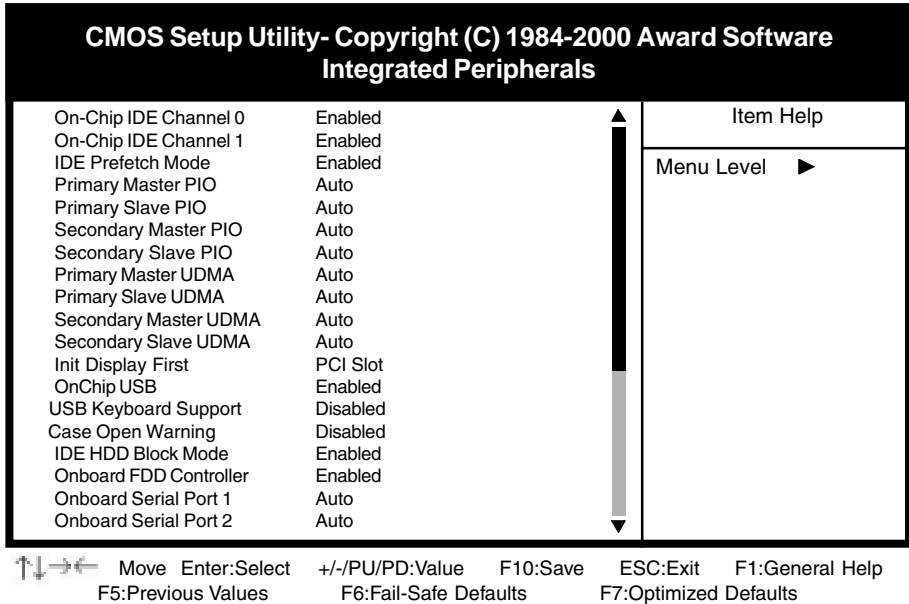

Figure 3-5 Integrated Peripherals Screen

### A. On Board IDE Control

#### On-chip IDE channel 0/1

You can set this to disable the On-chip IDE controller if you are going to add a higher performance IDE board.

#### IDE Primary/Secondary Master/Slave PIO

The four IDE PIO (programmed Input/Output) fields let you set a PIO mode (0-4) for each IDE device that the internal PCI IDE interface supports. Modes 0 through 4 provide successively increased performance. In Auto mode, the system automatically determines the best mode for each device.

### B. Init Display First

This function allows user to choose between AGP slot or VGA slot to initialize Display first .

### **C. OnChip USB**

Enable the on-board Universal Serial Bus (USB) controller if you want to connect a USB keyboard to your system. Note that if this setting is disabled, you can still temporarily use a USB keyboard during bootup so that you can enter BIOS and enable this setting. If you pass the bootup stage without enabling this function, your PS/2 keyboard will no longer work.

### **D. USB Keyboard Support**

Select Enabled if your system has a USB keyboard installed on the system board. If your system has no USB keyboard, select Disabled in this field.

### **E. Case Open Warning**

This board supports the case open warning(chassis instruction monitoring) feature of the management extension hardware by means of a mechanical or photo sensor switch attached to the motherboard through this 1x3-pin chassis security header. The mechanical switch is set to open for normal computer operation. Select enabled to use this function.

### **F. IDE HDD Block Mode**

Block mode is also called block transfer, multiple commands, or multiple sector read/write. If your IDE hard drive supports block mode (most new drives do), select Enabled for automatic detection of the optimal number of block read/writes per sector the drive can support.

### **G. Onboard FDC Controller**

Select Enabled if your system has a floppy disk controller (FDC) installed on the system board and you wish to use it. If you install an add-in FDC or the system has no floppy drive, select Disabled in this field.

### **H. UART 2 Mode**

This function allows you to select an operating mode for the second serial port. (Standard RS-232C serial port/HPSIR 1.0 specification/ASKIR 0.57-MB/sec infrared port)

### **I. Onboard Parallel Port**

Select a logical LPT port address and corresponding interrupt for the physical parallel port.

### **J. Parallel Port Mode**

Select an operating mode for the onboard parallel (printer) port. Select SPP unless you are certain your hardware and software support one of the other available modes.

### 3-5 Power Management Setup

This section provides information on the Green PC power management functions. By choosing the Power Management Setup option from the CMOS Setup Utility menu (Figure 3-1), the screen below is displayed. This sample screen contains the manufacturer's default values for the mainboard

CMOS Setup Utility- Copyright (C) 1984-2000 Award Software		Item Help
Power Management Setup		Menu Level ▶
ACPI function	Enabled	
▶ Power Management	Press Enter	
ACPI Suspend Type	S1(POS)	
PM Control by APM	Yes	
Video Off Option	Suspend -> Off	
Video Off Method	DPMS Support	
MODEM Use IRQ	3	
Soft-Off by PWRBTN	Delay 4 Sec	
State After Power Failure	Auto	
▶ Wake Up Events	Press Enter	

↑↓→← Move Enter:Select +/-/PU/PD:Value F10:Save ESC:Exit F1:General Help  
 F5:Previous Values F6:Fail-Safe Defaults F7:Optimized Defaults

Figure 3-6 Power Management Setup Screen

#### A. Advanced Configuration Power Interface (ACPI)

ACPI management enables the operating system to control the amount of power given to each device attached to the computer. With ACPI, the operating system can turn off peripherals devices, such as CD-ROM players, when they are not in use.

#### B. Power Management

Power management allows the computer to save electricity when it is not in use by entering increasingly deep power saving modes as shown by the diagram below.

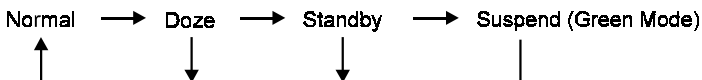

Figure 3-7 Power Saving Mode Flow Chart

### **C. Video Off Option**

This setting allow you to selects the power-saving modes during which the monitor goes blank:

### **D. Video Off Method**

This function serves as both a screen saver and power saver for monitors. See the next function, Video Off After, for setting the video timer.

**Blank** - BIOS will only blank the monitor's screen. The electricity saved in this mode is negligible and this function is only used as a screen saver to prevent screen damage while the screen is on but not in use.

**V/H SYNC+Blank** - The system turns off the vertical and horizontal synchronization ports, writes blanks to the VGA buffer and the monitor's electron gun turns off. This function requires a monitor with Green features in order to take advantage of the power saving function. If you enable this function and

do not have a Green monitor, the result will be the same as if you had selected Blank. This function serves as both a screen saver and an electricity saver.

**DPMS Supported** - Select this option if your video card supports the Display Power Management Signaling (DPMS) standard (i.e., you have a monitor that supports Green features). Use software supplied by your video subsystem to set video power management options.

### **E. Modem Use IRQ**

If your computer has an modem, use this function to tell BIOS which IRQ is being occupied by the modem card. When the system is in Green mode, the modem requires an IRQ assignment to wake up the system and perform tasks. This assignment is compliant with the APM 1.2 specification and is to be used in coordination with APM 1.2 compliant operating systems.

### **F. Soft-Off by PWR-BTTN**

When set to Delay 4 Sec., this function allows the power button to put the system in Suspend, a power saving mode. See Section 2-4 for operation instructions of the override power button operation which puts the system in Suspend mode. When set to Instant-Off the Soft-Off by PWR-BTTN function is disabled and the computer turns completely off when the power button is pressed.

### ***H. Power On By Modem/LAN***

When enabled, a modem/LAN that receives a signal will wake up the system from soft off and green mode. You should connect the modem to the COM port and turn on the resume event in green mode.

### ***I. Power On By Alarm***

When enabled, this setting allows the system to turn back on at a designated time of the month. User must designate date of month and time of day. This function is only available when using an ATX power supply and the Software Power-Off function to turn off the computer. See the Software Power-Off feature in Section 2-4 of this manual for instructions.

### 3-6 PNP/PCI Configuration

This section provides IRQ and DMA setting information. By choosing the PNP/PCI Configuration option from the CMOS Setup Utility menu (Figure 3-1), the screen below is displayed. This sample screen contains the manufacturer's default values for the mainboard.

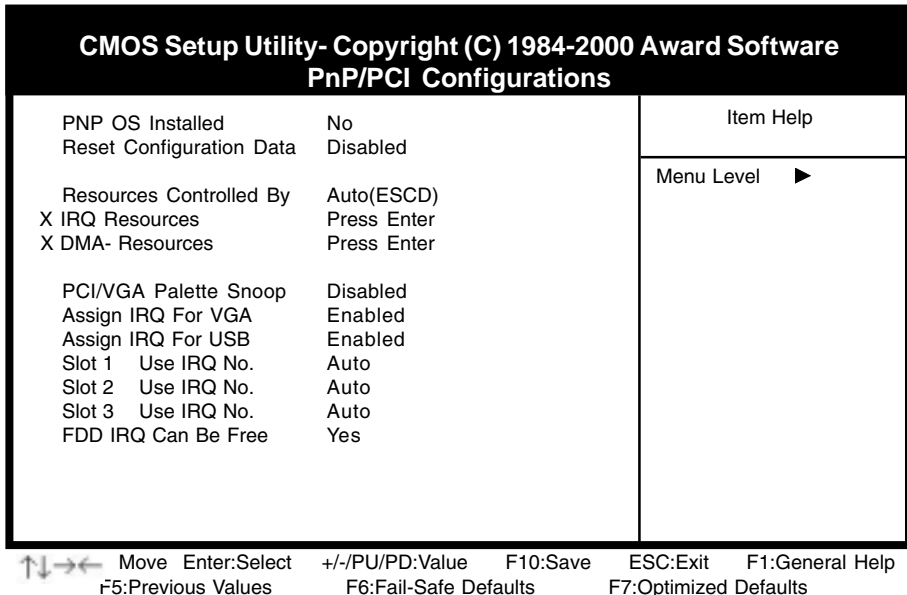

Figure 3-7 PnP/PCI Configurations Screen

#### A. PNP OS Installed

If you want to install a PNP compatible OS(such as Windows 95) set to Yes.

#### B. Resources Controlled By

When set to Manual the system BIOS will not refer to the ESCD for IRQ & DMA information. Instead, it will refer to the items in the setup menu for assigning IRQ & DMA. When set to Auto the system BIOS will refer to the ESCD for all legacy information.



ESCD (Extended System Configuration Data) provides a detailed format of the configuration data structures stored in flash memory. Each data structure defines the resources used by a device or a card in the system. This includes legacy and PCI/ISA PnP devices.

#### C. FDD IRQ Can Be Free

This function allows user to choose if the FDD IRQ is able to be freed up. The default setting is Yes and this does not allow the IRQ to be free.



### 3-7 PC Health Status

By choosing the PC Health Status option from the CMOS Setup Utility menu (Figure 3-1), the screen below is displayed. This sample screen contains the manufacturer's default values for the mainboard.

CMOS Setup Utility- Copyright (C) 1984-2000 Award Software		Item Help
PC Health Status		Menu Level ▶
Current CPU Temp.	31 °C/87 °F	
Current System Temp.	31 °C/87 °F	
Current CPU FAN Speed	3500 RPM	
Current SYS FAN Speed	3500 RPM	
VCore	0.00V	
Vcc SRAM	2.48V	
3.3V	<b>3.32V</b>	
<b>5 V</b>	<b>5.05V</b>	
<b>12 V</b>	<b>12.16V</b>	

↑↓→← Move Enter:Select +/-/PU/PD:Value F10:Save ESC:Exit F1:General Help  
 F5:Previous Values F6:Fail-Safe Defaults F7:Optimized Defaults

**Figure 3-8 PC Health Status Screen**

### 3-8 Frequency/Voltage Control

By choosing the **Frequency/Voltage Control** Setup option from the CMOS Setup Utility menu (Figure 3-1), the screen below is displayed. This sample screen contains the manufacturer's default values for the mainboard.

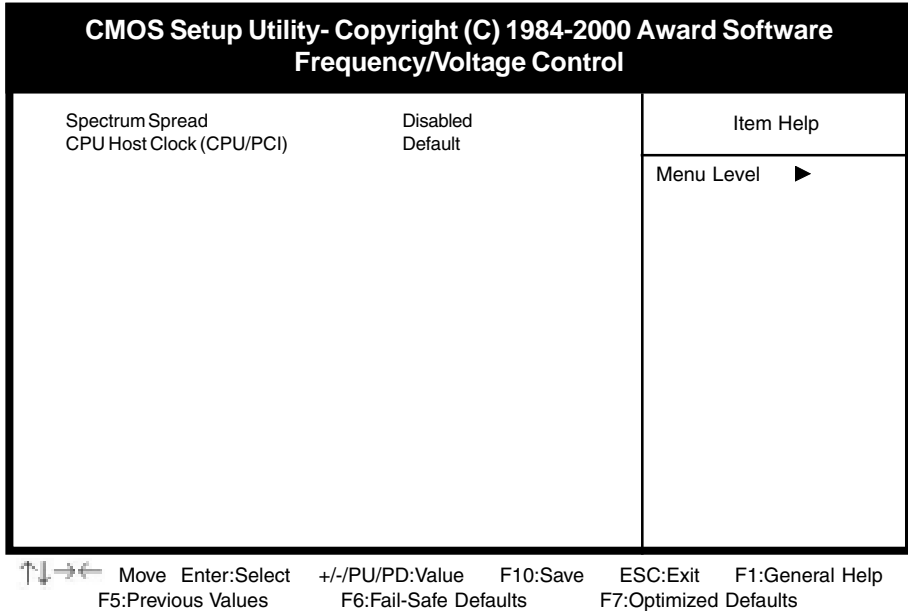

Figure 3-9 SeePU Setup Screen

#### A. Spectrum Spread

When Enabled this function will cause lower EMI by spreading the system frequency spectrum. For normal operation, disable this function.

#### B. CPU Host/PCI Clock

This feature allow your to select a timing combination for the CPU and the PCI bus.

### 3-9 Load Fail-Safe Defaults

Load Fail-Safe Defaults loads the default BIOS values directly from the CMOS Setup Utility menu (Figure3-1). If the stored record created by the setup program becomes corrupted and therefore unusable, these defaults will be loaded automatically when you turn on the computer.

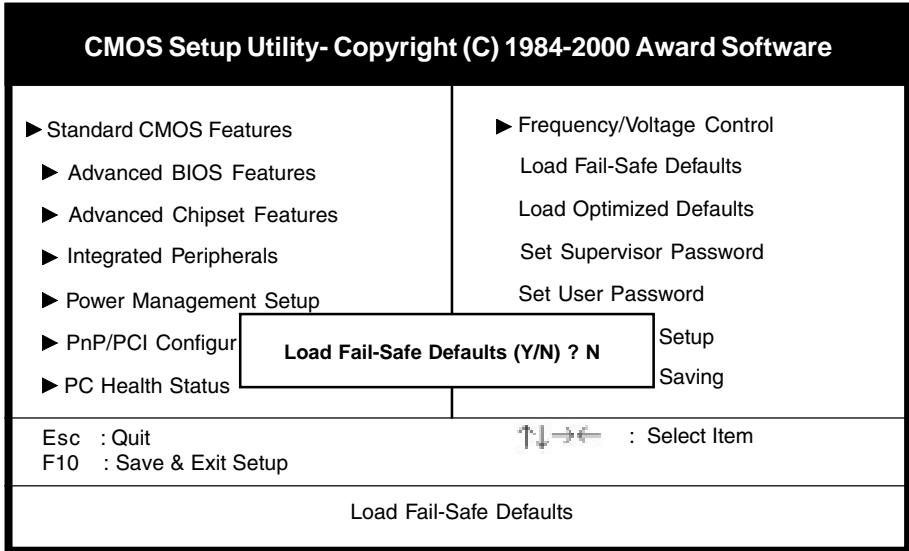

Figure 3-10 Load Fail-Safe Defaults Screen

### 3-10 Load Optimized Defaults

Load Optimized Defaults loads the default system values directly from the CMOS Setup Utility menu (Figure3-1). If the stored record created by the setup program becomes corrupted and therefore unusable, these defaults will be loaded automatically when you turn on the computer.

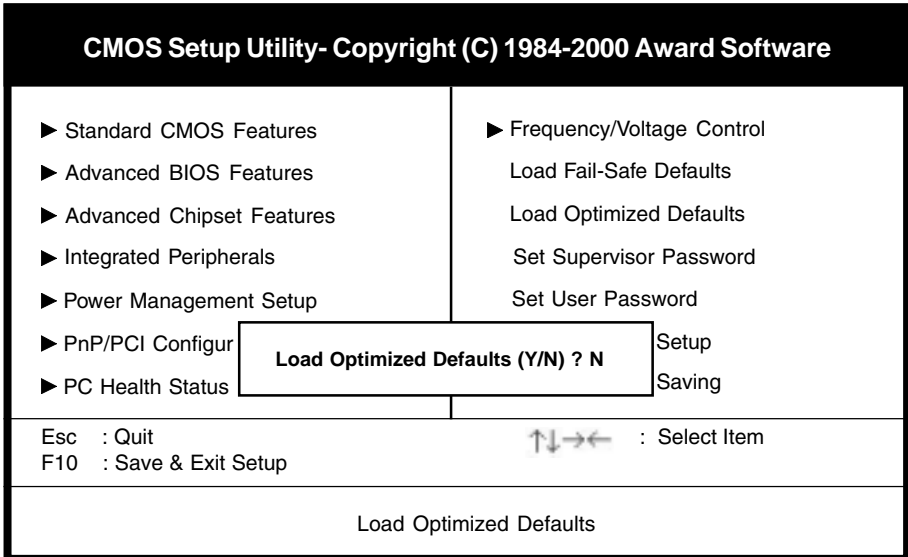

Figure 3-11 Load Optimized Defaults Screen

### 3-11 Supervisor Password & User Password Setting

There are four different variables that control password settings. The first two are located under the Security Option function in BIOS Features Setup Menu (Figure 3-1). When the Security Option function is set to Setup, a password is required to enter BIOS and change BIOS settings. When the Security Option function is set to System, a password is required to enter both BIOS and the computer's operating system (for example Windows 98) found on the boot drive. This is shown in Figures 3-12 and 3-13.

The third and fourth variables are user password and supervisor password selected in BIOS (Figure 3-1). The main purpose of separating user and supervisor is to allow only the supervisor to have control over the settings in BIOS. The user, on the other hand, is only allowed to access the computer's operating system and change the user password in BIOS (See Figure 3-13). Note that when there is no supervisor password set, the user password controls access to all BIOS settings (See Figure 3-12 below).

#### A. Set Either Supervisor Password or User Password

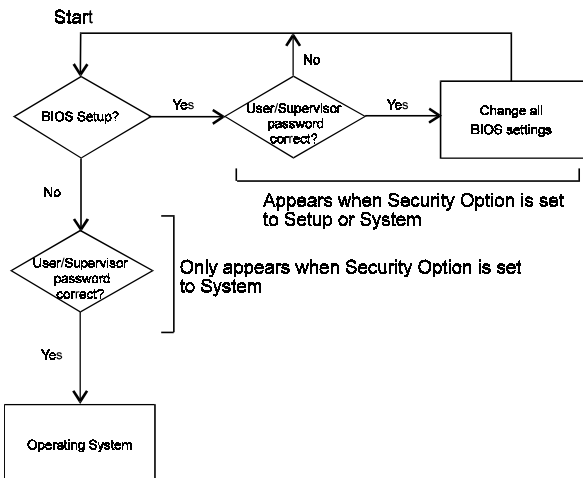

Figure 3-12 Set Either Supervisor or User Password

## B. Set Both Supervisor Password and User Password

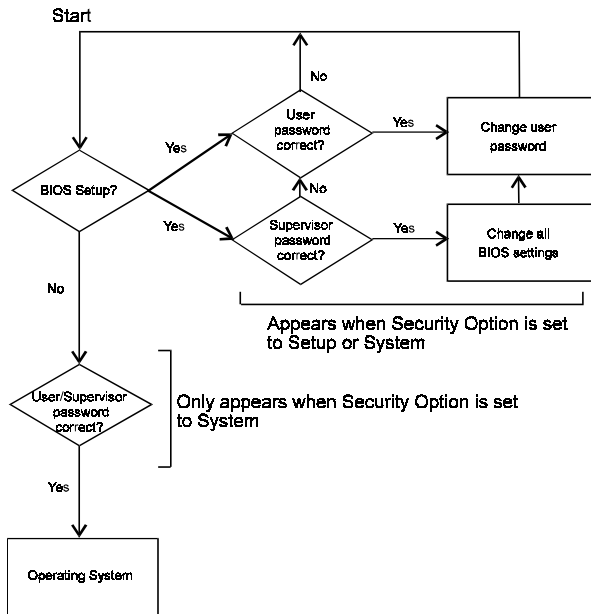

Figure 3-13 Set Both Supervisor and User Password

### 3-12 Save and Exit Setup

If you select this and type Y (for yes) followed by the [Enter] key, the values entered in the setup utilities will be recorded in the CMOS memory of the BIOS chip.

### 3-13 Exit Without Saving

Selecting this option and pressing Y followed by the [Enter] key lets you exit the Setup program without recording any new values or changing old ones.

### Brief Software Driver Guide

The Mainboard Software Guide is found on the CD-ROM that is enclosed with your mainboard and is a PDF file which must be viewed with Adobe's freeware called Acrobat® Reader. The Acrobat Reader software is also included on the same CD-ROM. See the Readme.txt file in the CD-ROM's root directory for installation instructions of the Acrobat Reader. The Mainboard software guide discusses the following items:

The following items are discussed in the TXT or PDF files:

- VIA Service Pack for Win9x/WinNT including Bus Master IDE drivers, AGP VxD IRQ routing mini port driver and etc.
- ACPI Patch Installation
- Sound Driver and Utility Installation
- USB Driver Installation
- Updating Your System BIOS
- Installing and Using a Desktop Management Interface (DMI) Utility for DOS



The DMI utility is a DOS utility, operating under Windows or other operating system might cause damage to the BIOS.

# ***Memo***



# Appendix I

## On Board I/O Addresses & IRQ Maps

System Resource	IRQ	I/O Address
1. Timer	IRQ0	040, 043
2. Keyboard	IRQ1	060, 064
3. Programmable INT	IRQ2	0020, 0021, 00A0, 00A1
4. COM2(B)	IRQ3	2F8, 2FF
5. COM1(A)	IRQ4	3F8, 3FF
6. Floppy	IRQ6	3F0, 3F7
7. LPT1	IRQ7	378, 37F
8. Real Time Clock	IRQ8	070, 071
9. PS/2 Mouse	IRQ12	060, 064
10. Math coprocessor	IRQ13	0F0, 0FF
11. IDE 1	IRQ14	1F0, 1F7
12. IDE 2	IRQ15	170, 177

 **IRQ 5, 9, 10 and 11 are available for interface cards.**

# ***Memo***

## Embedded Flash Utility

This mainboard is equipped with an Erasable Flash ROM and an Embedded Flash Utility which allows the user to update the BIOS to a newer version. Embedded Flash Utility eases BIOS upgrade and eliminate the compatibility issue between different Flash ROM type and version of Flash utility.

### Update Your System BIOS

1. Start computer, upon post, press ALT+F2 Keys to enter AWDFLASH setup.
2. Insert the floppy disk with the latest BIOS file into the floppy drive A(or B) and then press Enter to start programming.

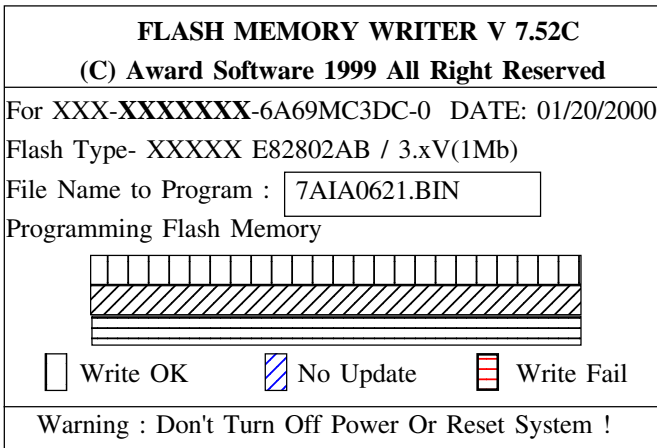

Sample of Programing Flash Memory Screen

3. When finished, the system will automatically Restart.

### Note:

- ✎ Flash BIOS Protection must be set to Disabled in the Advance Chipset Feature from the CMOS Setup Utility menu. See Chapter 3.
- ✎ Don't turn off or restart your system during programming process.
- ✎ Make sure that your floppy diskette have only one BIN file to aviod confussion.

# *Memo*