

K9A2GM / K9A2VM

MS-7501 (V1.X) Mainboard



Copyright Notice

The material in this document is the intellectual property of **MICRO-STAR INTERNATIONAL**. We take every care in the preparation of this document, but no guarantee is given as to the correctness of its contents. Our products are under continual improvement and we reserve the right to make changes without notice.

Trademarks

All trademarks are the properties of their respective owners.

Intel® and Pentium® are registered trademarks of Intel Corporation.

AMD, Athlon™, Athlon™ XP, Thoroughbred™, and Duron™ are registered trademarks of AMD Corporation.

NVIDIA, the NVIDIA logo, DualNet, and nForce are registered trademarks or trademarks of NVIDIA Corporation in the United States and/or other countries.

PS/2 and OS®/2 are registered trademarks of International Business Machines Corporation.

Windows® 95/98/2000/NT/XP are registered trademarks of Microsoft Corporation.

Netware® is a registered trademark of Novell, Inc.

Award® is a registered trademark of Phoenix Technologies Ltd.

AMI® is a registered trademark of American Megatrends Inc.

Revision History

Revision	Revision History	Date
V1.0	First release	April 2008

Technical Support

If a problem arises with your system and no solution can be obtained from the user's manual, please contact your place of purchase or local distributor. Alternatively, please try the following help resources for further guidance.

- 🔍 Visit the MSI website at <http://global.msi.com.tw/index.php?func=faqIndex> for FAQ, technical guide, BIOS updates, driver updates, and other information.
- 👤 Contact our technical staff at <http://support.msi.com.tw/>.

Safety Instructions

1. Always read the safety instructions carefully.
2. Keep this User's Manual for future reference.
3. Keep this equipment away from humidity.
4. Lay this equipment on a reliable flat surface before setting it up.
5. The openings on the enclosure are for air convection hence protects the equipment from overheating. **DO NOT COVER THE OPENINGS.**
6. Make sure the voltage of the power source and adjust properly 110/220V before connecting the equipment to the power inlet.
7. Place the power cord such a way that people can not step on it. Do not place anything over the power cord.
8. Always Unplug the Power Cord before inserting any add-on card or module.
9. All cautions and warnings on the equipment should be noted.
10. Never pour any liquid into the opening that could damage or cause electrical shock.
11. If any of the following situations arises, get the equipment checked by service personnel:
 - ▶ The power cord or plug is damaged.
 - ▶ Liquid has penetrated into the equipment.
 - ▶ The equipment has been exposed to moisture.
 - ▶ The equipment does not work well or you can not get it work according to User's Manual.
 - ▶ The equipment has dropped and damaged.
 - ▶ The equipment has obvious sign of breakage.
12. **DO NOT LEAVE THIS EQUIPMENT IN AN ENVIRONMENT UNCONDITIONED, STORAGE TEMPERATURE ABOVE 60°C (140°F), IT MAY DAMAGE THE EQUIPMENT.**



CAUTION: Danger of explosion if battery is incorrectly replaced.

Replace only with the same or equivalent type recommended by the manufacturer.



警告使用者：

此為甲類資訊技術設備，於居住環境中使用時，可能會造成射頻擾動，在此情況下，使用者會被要求採取某些適當的對策



廢電池請回收

For better environmental protection, waste batteries should be collected separately for recycling or special disposal.

FCC-B Radio Frequency Interference Statement

This equipment has been tested and found to comply with the limits for a Class B digital device, pursuant to Part



15 of the FCC Rules. These limits are designed to provide reasonable protection against harmful interference in a residential installation. This equipment generates, uses and can radiate radio frequency energy and, if not installed and used in accordance with the instructions, may cause harmful interference to radio communications. However, there is no guarantee that interference will not occur in a particular installation. If this equipment does cause harmful interference to radio or television reception, which can be determined by turning the equipment off and on, the user is encouraged to try to correct the interference by one or more of the measures listed below.

- ▶ Reorient or relocate the receiving antenna.
- ▶ Increase the separation between the equipment and receiver.
- ▶ Connect the equipment into an outlet on a circuit different from that to which the receiver is connected.
- ▶ Consult the dealer or an experienced radio/television technician for help.

Notice 1

The changes or modifications not expressly approved by the party responsible for compliance could void the user's authority to operate the equipment.

Notice 2

Shielded interface cables and A.C. power cord, if any, must be used in order to comply with the emission limits.

VOIR LA NOTICE D'INSTALLATION AVANT DE RACCORDER AU RESEAU.



This device complies with Part 15 of the FCC Rules. Operation is subject to the following two conditions:

- (1) this device may not cause harmful interference, and*
- (2) this device must accept any interference received, including interference that may cause undesired operation.*

WEEE (Waste Electrical and Electronic Equipment) Statement



ENGLISH

To protect the global environment and as an environmentalist, MSI must remind you that...

Under the European Union ("EU") Directive on Waste Electrical and Electronic Equipment, Directive 2002/96/EC, which takes effect on August 13, 2005, products of "electrical and electronic equipment" cannot be discarded as municipal waste anymore and manufacturers of covered electronic equipment will be obligated to take back such products at the end of their useful life. MSI will comply with the product take back requirements at the end of life of MSI-branded products that are sold into the EU. You can return these products to local collection points.

DEUTSCH

Hinweis von MSI zur Erhaltung und Schutz unserer Umwelt

Gemäß der Richtlinie 2002/96/EG über Elektro- und Elektronik-Altgeräte dürfen Elektro- und Elektronik-Altgeräte nicht mehr als kommunale Abfälle entsorgt werden. MSI hat europaweit verschiedene Sammel- und Recyclingunternehmen beauftragt, die in die Europäische Union in Verkehr gebrachten Produkte, am Ende seines Lebenszyklus zurückzunehmen. Bitte entsorgen Sie dieses Produkt zum gegebenen Zeitpunkt ausschliesslich an einer lokalen Altgerätesammelstelle in Ihrer Nähe.

FRANÇAIS

En tant qu'écologiste et afin de protéger l'environnement, MSI tient à rappeler ceci...

Au sujet de la directive européenne (EU) relative aux déchets des équipement électriques et électroniques, directive 2002/96/EC, prenant effet le 13 août 2005, que les produits électriques et électroniques ne peuvent être déposés dans les décharges ou tout simplement mis à la poubelle. Les fabricants de ces équipements seront obligés de récupérer certains produits en fin de vie. MSI prendra en compte cette exigence relative au retour des produits en fin de vie au sein de la communauté européenne. Par conséquent vous pouvez retourner localement ces matériels dans les points de collecte.

РУССКИЙ

Компания MSI предпринимает активные действия по защите окружающей среды, поэтому напоминаем вам, что...

В соответствии с директивой Европейского Союза (ЕС) по предотвращению загрязнения окружающей среды использованным электрическим и электронным оборудованием (директива WEEE 2002/96/EC), вступающей в силу 13 августа 2005 года, изделия, относящиеся к электрическому и электронному оборудованию, не могут рассматриваться как бытовой мусор, поэтому производители вышеперечисленного электронного оборудования обязаны принимать его для переработки по окончании срока службы. MSI обязуется соблюдать требования по приему продукции, проданной под маркой MSI на территории ЕС, в переработку по окончании срока службы. Вы можете вернуть эти изделия в специализированные пункты приема.

ESPAÑOL

MSI como empresa comprometida con la protección del medio ambiente, recomienda:

Bajo la directiva 2002/96/EC de la Unión Europea en materia de desechos y/o equipos electrónicos, con fecha de rigor desde el 13 de agosto de 2005, los productos clasificados como "eléctricos y equipos electrónicos" no pueden ser depositados en los contenedores habituales de su municipio, los fabricantes de equipos electrónicos, están obligados a hacerse cargo de dichos productos al término de su período de vida. MSI estará comprometido con los términos de recogida de sus productos vendidos en la Unión Europea al final de su período de vida. Usted debe depositar estos productos en el punto limpio establecido por el ayuntamiento de su localidad o entregar a una empresa autorizada para la recogida de estos residuos.

NEDERLANDS

Om het milieu te beschermen, wil MSI u eraan herinneren dat....

De richtlijn van de Europese Unie (EU) met betrekking tot Vervuiling van Elektrische en Electronische producten (2002/96/EC), die op 13 Augustus 2005 in zal gaan kunnen niet meer beschouwd worden als vervuiling.

Fabrikanten van dit soort producten worden verplicht om producten retour te nemen aan het eind van hun levenscyclus. MSI zal overeenkomstig de richtlijn handelen voor de producten die de merknaam MSI dragen en verkocht zijn in de EU. Deze goederen kunnen geretourneerd worden op lokale inzamelingspunten.

SRPSKI

Da bi zaštitili prirodnu sredinu, i kao preduzeće koje vodi računa o okolini i prirodnoj sredini, MSI mora da vas podesti da...

Po Direktivi Evropske unije ("EU") o odbačenju elektonskoj i električnoj opremi, Direktiva 2002/96/EC, koja stupa na snagu od 13. Avgusta 2005, proizvodi koji spadaju pod "elektonsku i električnu opremu" ne mogu više biti odbačeni kao običan otpad i proizvođači ove opreme biće prinudeni da uzmu natrag ove proizvode na kraju njihovog uobičajenog veka trajanja. MSI će poštovati zahtev o preuzimanju ovakvih proizvoda kojima je istekao vek trajanja, koji imaju MSI oznaku i koji su prodati u EU. Ove proizvode možete vratiti na lokalnim mestima za prikupljanje.

POLSKI

Aby chronić nasze środowisko naturalne oraz jako firma dbająca o ekologię, MSI przypomina, że...

Zgodnie z Dyrektywą Unii Europejskiej ("UE") dotyczącą odpadów produktów elektrycznych i elektronicznych (Dyrektywa 2002/96/EC), która wchodzi w życie 13 sierpnia 2005, tzw. "produkty oraz wyposażenie elektryczne i elektroniczne" nie mogą być traktowane jako śmieć komunalne, tak więc producenci tych produktów będą zobowiązani do odbierania ich w momencie gdy produkt jest wycofywany z użycia. MSI wypełni wymagania UE, przyjmując produkty (sprzedawane na terenie Unii Europejskiej) wycofywane z użycia. Produkty MSI będzie można zwracać w wyznaczonych punktach zbiorczych.

TÜRKÇE

Çevreci özelliğiyle bilinen MSI dünyada çevreyi korumak için hatırlatır:

Avrupa Birliği (AB) Kararnamesi Elektrik ve Elektronik Malzeme Atığı, 2002/96/EC Kararnamesi altında 13 Ağustos 2005 tarihinden itibaren geçerli olmak üzere, elektrikli ve elektronik malzemeler diğer atıklar gibi çöpe atılmayacak ve bu elektronik cihazların üreticileri, cihazların kullanım süreleri bittikten sonra ürünleri geri toplamakla yükümlü olacaktır. Avrupa Birliği'ne satılan MSI markalı ürünlerin kullanım süreleri bittiğinde MSI ürünlerin geri alınması isteği ile işbirliği içerisinde olacaktır. Ürünlerinizi yerel toplama noktalarına bırakabilirsiniz.

ČESKY

Záleží nám na ochraně životního prostředí - společnost MSI upozorňuje...

Podle směrnice Evropské unie ("EU") o likvidaci elektrických a elektronických výrobků 2002/96/EC platné od 13. srpna 2005 je zakázáno likvidovat "elektrické a elektronické výrobky" v běžném komunálním odpadu a výrobci elektronických výrobků, na které se tato směrnice vztahuje, budou povinni odebírat takové výrobky zpět po skončení jejich životnosti. Společnost MSI splní požadavky na odebrání výrobků značky MSI, prodávaných v zemích EU, po skončení jejich životnosti. Tyto výrobky můžete odevzdat v místních sběrnách.

MAGYAR

Annak érdekében, hogy környezetünket megvédjük, illetve környezetvédként fellépve az MSI emlékezteti Önt, hogy ...

Az Európai Unió („EU”) 2005. augusztus 13-án hatályba lépő, az elektromos és elektronikus berendezések hulladékairól szóló 2002/96/EK irányelve szerint az elektromos és elektronikus berendezések többé nem kezelhetők lakossági hulladékként, és az ilyen elektronikus berendezések gyártói kötelessé válnak az ilyen termékek visszavételére azok hasznos élettartama végén. Az MSI betartja a termékvisszavételrel kapcsolatos követelményeket az MSI márkánév alatt az EU-n belül értékesített termékek esetében, azok élettartamának végén. Az ilyen termékeket a legközelebbi gyűjtőhelyre viheti.

ITALIANO

Per proteggere l'ambiente, MSI, da sempre amica della natura, ti ricorda che...

In base alla Direttiva dell'Unione Europea (EU) sullo Smaltimento dei Materiali Elettrici ed Elettronici, Direttiva 2002/96/EC in vigore dal 13 Agosto 2005, prodotti appartenenti alla categoria dei Materiali Elettrici ed Elettronici non possono più essere eliminati come rifiuti municipali: i produttori di detti materiali saranno obbligati a ritirare ogni prodotto alla fine del suo ciclo di vita. MSI si adeguerà a tale Direttiva ritirando tutti i prodotti marchiati MSI che sono stati venduti all'interno dell'Unione Europea alla fine del loro ciclo di vita. È possibile portare i prodotti nel più vicino punto di raccolta.

CONTENTS

Copyright Notice	ii
Trademarks	ii
Revision History	ii
Technical Support	ii
Safety Instructions	iii
FCC-B Radio Frequency Interference Statement	iv
WEEE (Waste Electrical and Electronic Equipment) Statement	v
Chapter 1 Getting Started	1-1
Mainboard Specifications	1-2
Mainboard Layout	1-4
Packing Checklist	1-5
Chapter 2 Hardware Setup	2-1
Quick Components Guide	2-2
CPU (Central Processing Unit)	2-3
Memory	2-6
Power Supply	2-8
Back Panel	2-9
Connector	2-11
Slot	2-18
Jumper	2-19
Chapter 3 BIOS Setup	3-1
Entering Setup	3-2
The Main Menu	3-4
Standard CMOS Features	3-6
Advanced BIOS Features	3-9
Integrated Peripherals	3-12
Power Management Setup	3-14
H/W Monitor	3-17
Cell Menu	3-18
Load Fail-Safe / Optimized Defaults	3-22
BIOS Setting Password	3-23
Appendix A Realtek ALC888 Audio	A-1
Installing the Realtek HD Audio Driver	A-2
Software Configuration	A-4
Hardware Setup	A-19
Appendix B SATA RAID	B-1
RAID Configuration	B-2

Chapter 1

Getting Started

Thank you for choosing the K9A2GM / K9A2VM (MS-7501 v1.X) Micro-ATX mainboard. The K9A2GM / K9A2VM is based on **AMD® 780G/780V & SB700** chipsets for optimal system efficiency. Designed to fit the advanced AMD® Phenom / Athlon 64 / Sempron processors in Socket AM2 / AM2+, the K9A2GM / K9A2VM delivers a high performance and professional desktop platform solution.

Mainboard Specifications

Processor

- Supports AMD Phenom / Athlon 64 / Sempron processors
 - Supports 4-pin CPU fan pinheader with Fan Speed Control
 - Supports up to 5000+ and above
- (For the latest information about CPU, please visit <http://global.msi.com.tw/index.php?func=cpuform>)

FSB

- Hyper Transport supports up to 2.6GHz

Chipset

- North Bridge: AMD 780G / 780V
- South Bridge: AMD SB700

Memory

- DDR2 533/667/800/1066 SDRAM (240 pins / 1.8V)
 - 4 DDR2 DIMM slots (8GB Max)
- (For more information on compatible components, please visit <http://global.msi.com.tw/index.php?func=testreport>)

LAN

- Gigabit Fast Ethernet by Realtek RTL8111C

IEEE 1394 (Optional)

- Chip integrated by JMicron 381
- Transfer rate is up to 400Mb/s

Audio

- Chip integrated by Realtek ALC888
- Flexible 8-channel audio with jack sensing
- Compliant with Azalia 1.0 Spec

IDE

- 1 IDE port by SB700
- Supports Ultra DMA 33/66/100/133 mode
- Supports PIO, Bus Master operation mode

SATA

- 4 SATA II ports by SB700
- Supports 4 SATA II devices
- Supports storage and data transfers at up to 300MB/s

Floppy

- 1 floppy port
- Supports 1 FDD with 360KB, 720KB, 1.2MB, 1.44MB and 2.88MB

Connectors

● Back Panel

- 1 PS/2 mouse port
- 1 PS/2 keyboard port
- 1 IEEE 1394 port (Optional)
- 4 USB 2.0 ports
- 1 Gigabit LAN jack
- 1 VGA port
- 1 DVI port (Optional)
- 1 HDMI port (Optional)
- 6 flexible audio jacks

● Onboard Connectors

- 3 USB 2.0 connectors
- 1 IEEE 1394 connector (Optional)
- 1 TPM connector (Optional)
- 1 serial port connector
- 1 CD-In connector
- 1 SPDIF-Out connector
- 1 chassis intrusion switch pinheader
- 1 front panel audio connector

Slots

- 1 PCI Express x16 slot
- 1 PCI Express x1 slot
- 2 32-bit/33MHz PCI slots

Form Factor

- M-ATX (24.4cm X 24.4 cm)

Mounting

- 6 mounting holes

Mainboard Layout

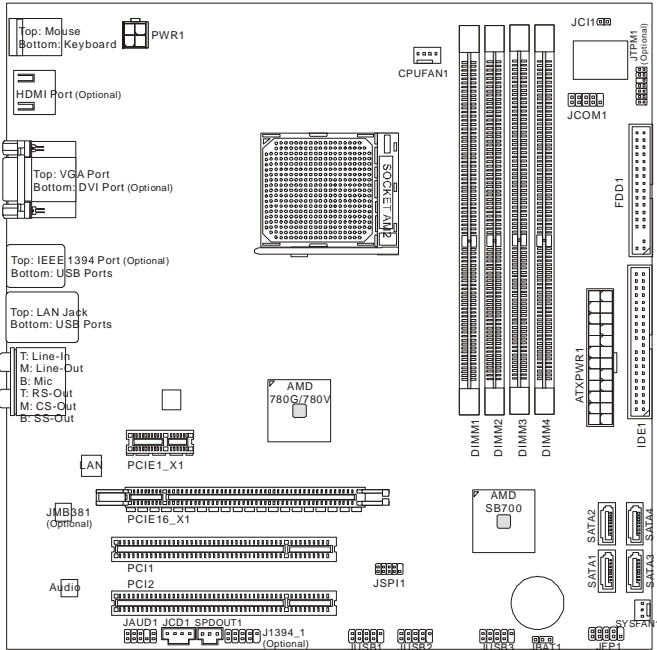

**K9A2GM / K9A2VM (MS-7501 v1.X)
Micro-ATX Mainboard**

Packing Checklist



MSI Motherboard

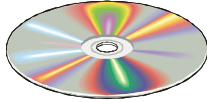

MSI Driver/Utility CD



SATA Cable



Power Cable



Standard Cable for
IDE Devices



Back IO Shield
(for reference only)



User's Guide

*** The pictures are for reference only and may vary from the packing contents of the product you purchased.**

Chapter 2

Hardware Setup

This chapter provides you with the information about hardware setup procedures. While doing the installation, be careful in holding the components and follow the installation procedures. For some components, if you install in the wrong orientation, the components will not work properly.

Use a grounded wrist strap before handling computer components. Static electricity may damage the components.

Quick Components Guide

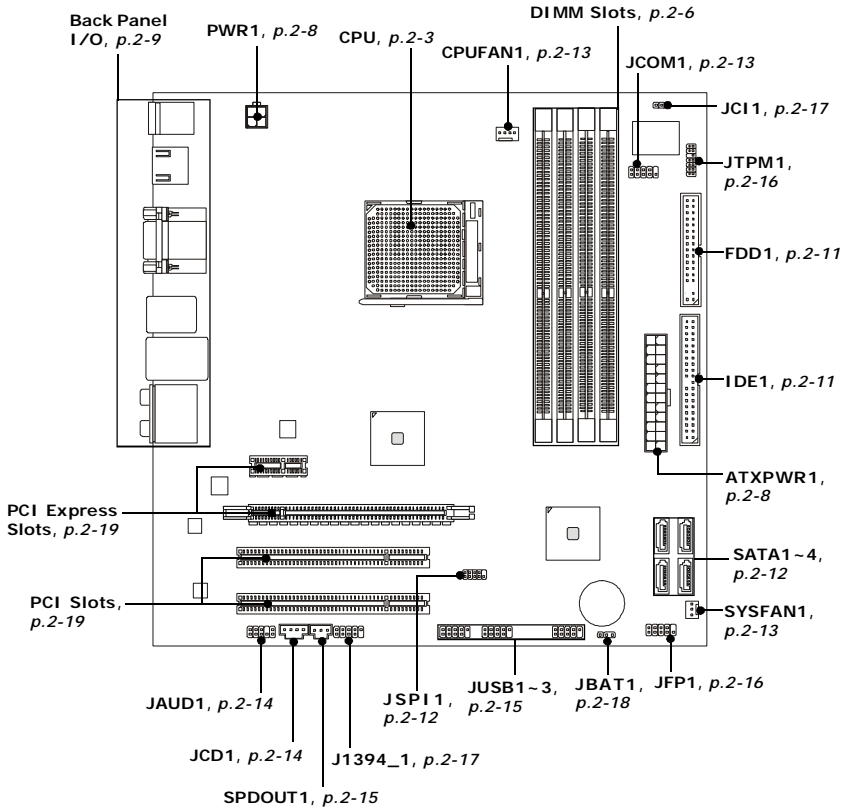

CPU (Central Processing Unit)

The mainboard supports AMD® Phenom / Athlon 64 / Sempron processors in Socket AM2 / AM2+. The Socket AM2 / AM2+ offers easy CPU installation. When you are installing the CPU, **make sure the CPU has a heat sink and a cooling fan attached on the top to prevent overheating.** If you do not have the heat sink and cooling fan, contact your dealer to purchase and install them before turning on the computer.

For the latest information about CPU, please visit <http://global.msi.com.tw/index.php?func=cpuform>.



Important

Overheating

Overheating will seriously damage the CPU and system. Always make sure the cooling fan can work properly to protect the CPU from overheating. Make sure that you apply an even layer of thermal paste (or thermal tape) between the CPU and the heatsink to enhance heat dissipation.

Replacing the CPU

While replacing the CPU, always turn off the power supply or unplug the power supply's power cord from the grounded outlet first to ensure the safety of CPU.

Overclocking

*This mainboard is designed to support overclocking. However, please make sure your components are able to tolerate such abnormal setting, while doing overclocking. Any attempt to operate beyond product specifications is not recommended. **We do not guarantee the damages or risks caused by inadequate operation or beyond product specifications.***

CPU Installation Procedures for Socket AM2/ AM2+

1. Please turn off the power and unplug the power cord before installing the CPU.
2. Pull the lever sideways away from the socket. Make sure that you raise the lever up to a 90-degree angle.
3. Look for the gold arrow on the CPU. The gold arrow should point as shown in the picture. The CPU can only fit in the correct orientation. Lower the CPU down onto the socket.
4. If the CPU is correctly installed, the pins should be completely embedded into the socket and can not be seen. Please note that any violation of the correct installation procedures may cause permanent damage to your mainboard.
5. Press the CPU down firmly into the socket and close the lever. As the CPU is likely to move while the lever is being closed, always close the lever with your fingers pressing tightly on top of the CPU to make sure the CPU is properly and completely embedded into the socket.

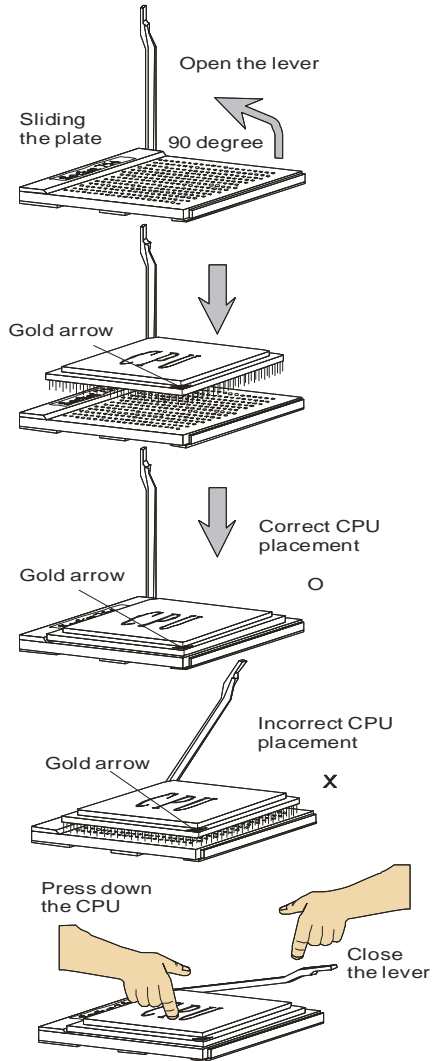

Installing CPU Cooler Set

When you are installing the CPU, **make sure the CPU has a heat sink and a cooling fan attached on the top to prevent overheating.** If you do not have the heat sink and cooling fan, contact your dealer to purchase and install them before turning on the computer.



Important

1. Read the CPU status in BIOS (Chapter 3).
2. Mainboard photos shown in this section are for demonstration of the CPU/cooler installation only. The appearance of your mainboard may vary depending on the model you purchase.

1. Position the cooling set onto the retention mechanism.

Hook one end of the clip to hook first.

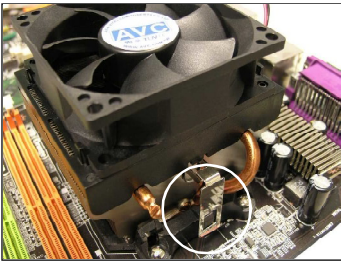

3. Fasten down the lever.

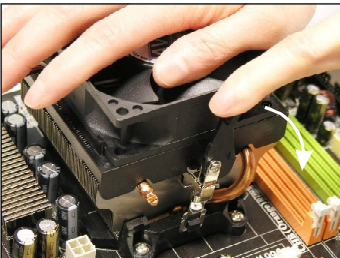

2. Then press down the other end of the clip to fasten the cooling set on the top of the retention mechanism. Locate the Fix Lever and lift up it.

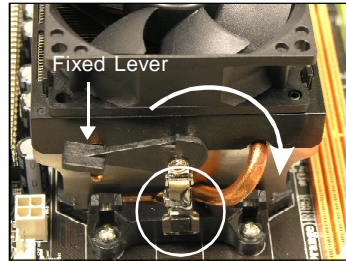

4. Attach the CPU Fan cable to the CPU fan connector on the mainboard.

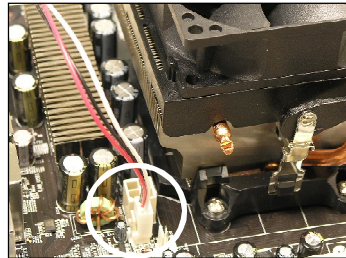

Memory

These DIMM slots are intended for memory modules.

For more information on compatible components, please visit <http://global.msi.com.tw/index.php?func=testreport>

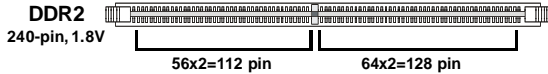

Dual-Channel Memory Population Rules

In Dual-Channel mode, the memory modules can transmit and receive data with two data bus lines simultaneously. Enabling Dual-Channel mode can enhance the system performance. Please refer to the following illustrations for population rules under Dual-Channel mode.

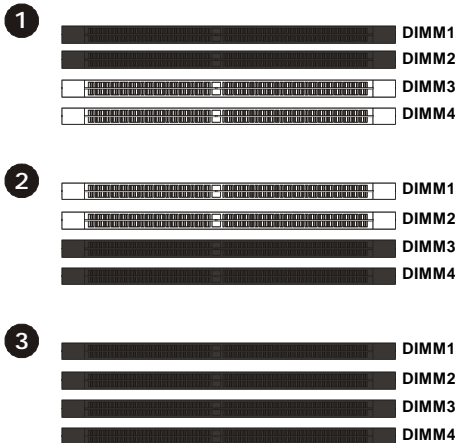

Installing Memory Modules

1. The memory module has only one notch on the center and will only fit in the right orientation.
2. Insert the memory module vertically into the DIMM slot. Then push it in until the golden finger on the memory module is deeply inserted in the DIMM slot. The plastic clip at each side of the DIMM slot will automatically close when the memory module is properly seated.



Important

You can barely see the golden finger if the memory module is properly inserted in the DIMM slot.

3. Manually check if the memory module has been locked in place by the DIMM slot clips at the sides.

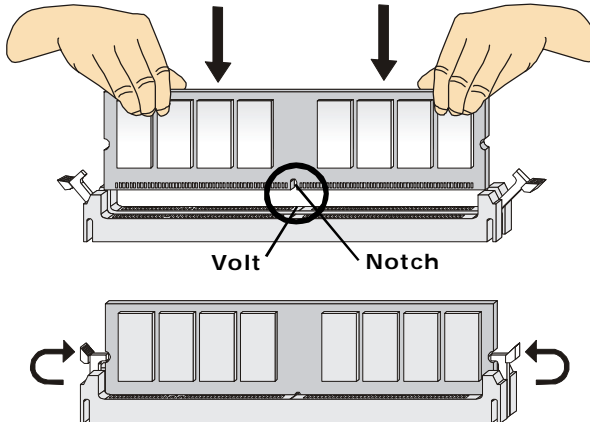

Important

- In Dual-Channel mode, make sure that you install memory modules of **the same type and density** in different channel DIMM slots.
- To enable successful system boot-up, always insert the memory modules into the **DIMM1** first.
- Due to the chipset resource deployment, the system density will only be detected up to 7+GB (not full 8GB) when each DIMM is installed with a 2GB memory module.

Power Supply

ATX 24-Pin Power Connector: ATXPWR1

This connector allows you to connect an ATX 24-pin power supply. To connect the ATX 24-pin power supply, make sure the plug of the power supply is inserted in the proper orientation and the pins are aligned. Then push down the power supply firmly into the connector.

You may use the 20-pin ATX power supply as you like. If you'd like to use the 20-pin ATX power supply, please plug your power supply along with pin 1 & pin 13 (refer to the image at the right hand). There is also a foolproof design on pin 11, 12, 23 & 24 to avoid wrong installation.



ATXPWR1

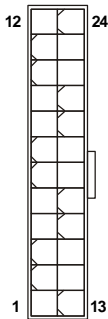

Pin Definition

PIN	SIGNAL	PIN	SIGNAL
1	+3.3V	13	+3.3V
2	+3.3V	14	-12V
3	GND	15	GND
4	+5V	16	PS-ON#
5	GND	17	GND
6	+5V	18	GND
7	GND	19	GND
8	PWROK	20	Res
9	5VSB	21	+5V
10	+12V	22	+5V
11	+12V	23	+5V
12	+3.3V	24	GND

ATX 12V Power Connector: PWR1

This power connector is used to provide power to the CPU.

PWR1



Pin Definition

PIN	SIGNAL
1	GND
2	GND
3	12V
4	12V



Important

1. Make sure that all the connectors are connected to proper power supplies to ensure stable operation of the mainboard.
2. Power supply of 350 watts (and above) is highly recommended for system stability.

Back Panel

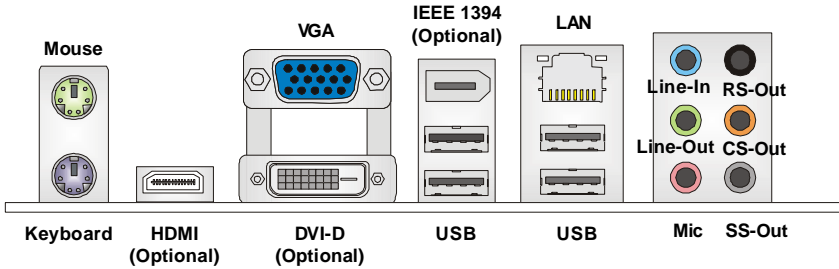

► Mouse/Keyboard

The standard PS/2® mouse/keyboard DIN connector is for a PS/2® mouse/keyboard.

► HDMI Port (Optional)

The High-Definition Multimedia Interface (HDMI) is an all-digital audio/video interface capable of transmitting uncompressed streams. HDMI supports all TV format, including standard, enhanced, or high-definition video, plus multi-channel digital audio on a single cable.

► VGA Port

The DB15-pin female connector is provided for monitor.

► DVI-D Port (Optional)

The DVI-D (Digital Visual Interface-Digital) connector allows you to connect an LCD monitor. It provides a high-speed digital interconnection between the computer and its display device. To connect an LCD monitor, simply plug your monitor cable into the DVI connector, and make sure that the other end of the cable is properly connected to your monitor (refer to your monitor manual for more information.)

► IEEE 1394 Port (Optional)

The 1394 port on the back panel provides connection to 1394 devices.

► USB Port

The USB (Universal Serial Bus) port is for attaching USB devices such as keyboard, mouse, or other USB-compatible devices.

► **LAN**

The standard RJ-45 LAN jack is for connection to Local Area Network (LAN). You can connect a network cable to it.

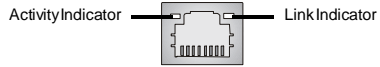

LED	Color	LED State	Condition
Left	Green	Off	LAN link is not established.
		On (steady state)	LAN link is established.
		On (brighter & pulsing)	The computer is communicating with another computer on the LAN.
Right	Green	Off	10 Mbit/sec data rate is selected.
		On	100 Mbit/sec data rate is selected.
	Orange	On	1000 Mbit/sec data rate is selected.

► **Audio Ports**

These audio connectors are used for audio devices. You can differentiate the color of the audio jacks for different audio sound effects.

- **Line-In (Blue)** - Line In, is used for external CD player, tape player or other audio devices.
- **Line-Out (Green)** - Line Out, is a connector for speakers or headphones.
- **Mic (Pink)** - Mic, is a connector for microphones.
- **RS-Out (Black)** - Rear-Surround Out in 4/ 5.1/ 7.1 channel mode.
- **CS-Out (Orange)** - Center/ Subwoofer Out in 5.1/ 7.1 channel mode.
- **SS-Out (Gray)** - Side-Surround Out 7.1 channel mode.

Connector

Floppy Disk Drive Connector: FDD1

This connector supports 360KB, 720KB, 1.2MB, 1.44MB or 2.88MB floppy disk drive.



FDD1

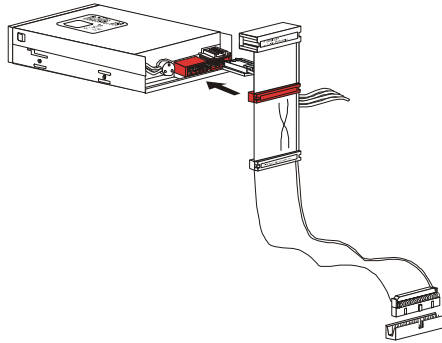

IDE Connector: IDE1

This connector supports IDE hard disk drives, optical disk drives and other IDE devices.



IDE1

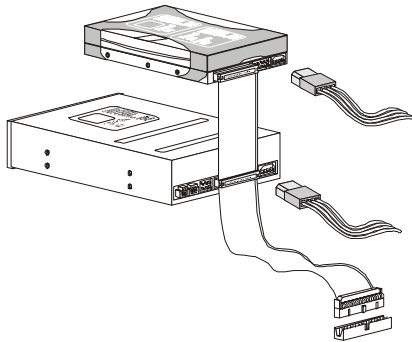

Important

If you install two IDE devices on the same cable, you must configure the drives separately to master / slave mode by setting jumpers. Refer to IDE device's documentation supplied by the vendors for jumper setting instructions.

SPI Flash ROM Connector: JSPI1

This connector is used to flash SPI flash ROM.

Pin Definition



Pin	Description	Pin	Description
1	VCC3_SB	2	VCC3_SB
3	SPI_MISO_F	4	SPI_MOSI_F
5	SPI_CS0_F#	6	SPI_CLK_F
7	GND	8	GND
9	SPI_HOLD#	10	NC

Serial ATA Connector: SATA1, SATA2, SATA3, SATA4

This connector is a high-speed Serial ATA interface port. Each connector can connect to one Serial ATA device.

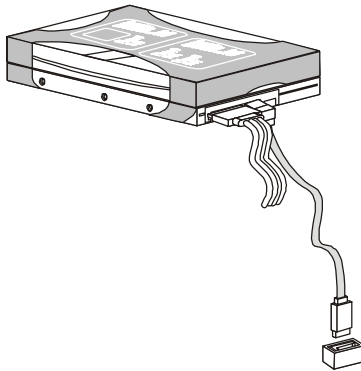
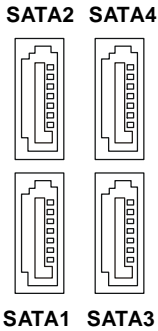

Important

Please do not fold the Serial ATA cable into 90-degree angle. Otherwise, data loss may occur during transmission.

Serial Port Connector: JCOM1

This connector is a 16550A high speed communications port that sends/receives 16 bytes FIFOs. You can attach a serial device to it.

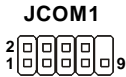

Pin Definition

PIN	SIGNAL	DESCRIPTION
1	DCD	Data Carry Detect
2	SIN	Serial In or Receive Data
3	SOUT	Serial Out or Transmit Data
4	DTR	Data Terminal Ready
5	GND	Ground
6	DSR	Data SetReady
7	RTS	Request To Send
8	CTS	Clear To Send
9	RI	Ring Indicate

Fan Power Connector: CPUFAN1, SYSFAN1

The fan power connectors support system cooling fan with +12V. When connecting the wire to the connectors, always note that the red wire is the positive and should be connected to the +12V; the black wire is Ground and should be connected to GND. If the mainboard has a System Hardware Monitor chipset onboard, you must use a specially designed fan with speed sensor to take advantage of the CPU fan control.

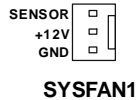
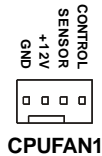

Important

1. Please refer to the recommended CPU fans at processor's official website or consult the vendors for proper CPU cooling fan.
2. CPUFAN1 supports fan control. You can activate the Smart Fan function in the BIOS Setup Utility to automatically control the CPU fan speed according to the actual CPU temperature.
3. Fan/heatsink with 3 or 4 pins are both available for CPUFAN1.

CD-In Connector: JCD1

This connector is provided for external audio input..

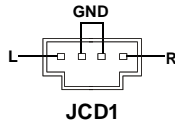

Front Panel Audio Connector: JAUD1

This connector allows you to connect the front panel audio and is compliant with Intel® Front Panel I/O Connectivity Design Guide.



HD Audio Pin Definition

PIN	SIGNAL	DESCRIPTION
1	MIC_L	Microphone - Left channel
2	GND	Ground
3	MIC_R	Microphone - Right channel
4	PRESENCE#	Active low signal-signals BIOS that a High Definition Audio dongle is connected to the analog header. PRESENCE# = 0 when a High Definition Audio dongle is connected
5	LINE out_R	Analog Port - Right channel
6	MIC_JD	Jack detection return from front panel microphone JACK1
7	Front_JD	Jack detection sense line from the High Definition Audio CODEC jack detection resistor network
8	NC	No control
9	LINE out_L	Analog Port - Left channel
10	LINEout_JD	Jack detection return from frontpanel JACK2

S/PDIF-Out Connector: SPDOUT1 (Optional)

This connector is used to connect S/PDIF (Sony & Philips Digital Interconnect Format) interface for digital audio transmission.

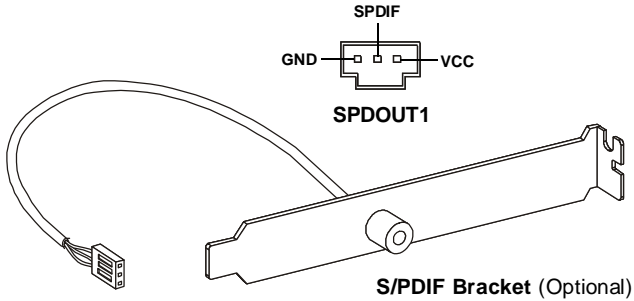

Front USB Connector: JUSB1, JUSB2, JUSB3

This connector, compliant with Intel® I/O Connectivity Design Guide, is ideal for connecting high-speed USB interface peripherals such as **USB HDD, digital cameras, MP3 players, printers, modems and the like.**

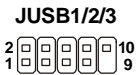

Pin Definition

PIN	SIGNAL	PIN	SIGNAL
1	VCC	2	VCC
3	USB0-	4	USB1-
5	USB0+	6	USB1+
7	GND	8	GND
9	Key (no pin)	10	USBOC

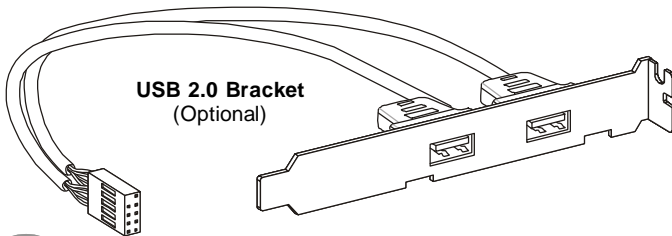

Important

Note that the pins of VCC and GND must be connected correctly to avoid possible damage.

Front Panel Connector: JFP1

This connector is provided for electrical connection to the front panel switches/LEDs and is compliant with Intel® Front Panel I/O Connectivity Design Guide.

JFP1 Pin Definition

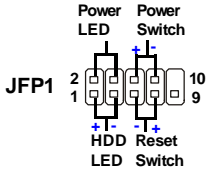

PIN	SIGNAL	DESCRIPTION
1	HD_LED +	Hard disk LED pull-up
2	FPPWR/SLP	MSG LED pull-up
3	HD_LED -	Hard disk active LED
4	FPPWR/SLP	MSG LED pull-up
5	RST_SW -	Reset Switch low reference pull-down to GND
6	PWR_SW+	Power Switch high reference pull-up
7	RST_SW +	Reset Switch high reference pull-up
8	PWR_SW -	Power Switch low reference pull-down to GND
9	RSVD_DNU	Reserved. Do not use.

TPM Connector: JTPM1 (Optional)

This connector is designed to connect an optional TPM (Trusted Platform Module). Please refer to the TPM security platform manual for more details.

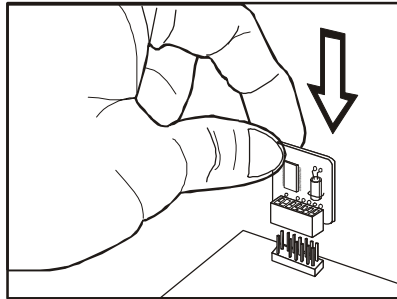
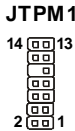

Pin	Signal	Description	Pin	Signal	Description
1	LCLK	LPCclock	2	3V dual/3V_STB	3V dual or 3V standby power
3	LRST#	LPC reset	4	VCC3	3.3V power
5	LAD0	LPC address & data pin0	6	SIRQ	Serial IRQ
7	LAD1	LPC address & data pin1	8	VCC5	5V power
9	LAD2	LPC address & data pin2	10	KEY	No pin
11	LAD3	LPC address & data pin3	12	GND	Ground
13	LFRAME#	LPCFrame	14	GND	Ground

Chassis Intrusion Connector: JCI1

This connector connects to the chassis intrusion switch cable. If the chassis is opened, the chassis intrusion mechanism will be activated. The system will record this status and show a warning message on the screen. To clear the warning, you must enter the BIOS utility and clear the record.

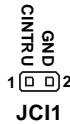

IEEE1394 Connector: J1394_1 (Optional)

This connector allows you to connect the IEEE1394 device via an optional IEEE1394 bracket.

Pin Definition

PIN	SIGNAL	PIN	SIGNAL
1	TPA+	2	TPA-
3	Ground	4	Ground
5	TPB+	6	TPB-
7	Cablepower	8	Cablepower
9	Key (no pin)	10	Ground

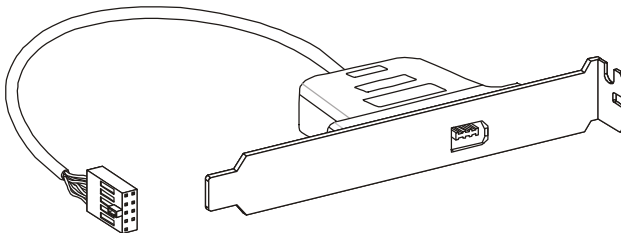
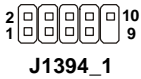

IEEE1394 Bracket (Optional)

Jumper

Clear CMOS Jumper: JBAT1

There is a CMOS RAM onboard that has a power supply from an external battery to keep the data of system configuration. With the CMOS RAM, the system can automatically boot OS every time it is turned on. If you want to clear the system configuration, set the jumper to clear data.



Important

You can clear CMOS by shorting 2-3 pin while the system is off. Then return to 1-2 pin position. Avoid clearing the CMOS while the system is on; it will damage the mainboard.

Slot

PCI (Peripheral Component Interconnect) Express Slot

The PCI Express slot supports the PCI Express interface expansion card.

The PCI Express x 16 slot supports up to 4.0 GB/s transfer rate.

The PCI Express x 1 slot supports up to 250 MB/s transfer rate.

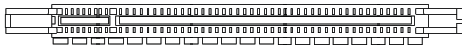

PCI Express x16 Slot

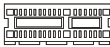

PCI Express x1 Slot

PCI (Peripheral Component Interconnect) Slot

The PCI slot supports LAN card, SCSI card, USB card, and other add-on cards that comply with PCI specifications.

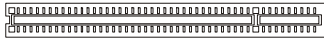

32-bit PCI Slot



Important

When adding or removing expansion cards, make sure that you unplug the power supply first. Meanwhile, read the documentation for the expansion card to configure any necessary hardware or software settings for the expansion card, such as jumpers, switches or BIOS configuration.

PCI Interrupt Request Routing

The IRQ, acronym of interrupt request line and pronounced I-R-Q, are hardware lines over which devices can send interrupt signals to the microprocessor. The PCI IRQ pins are typically connected to the PCI bus pins as follows:

	Order 1	Order 2	Order 3	Order 4
PCISlot 1	INTA#	INTB#	INTC#	INTD#
PCISlot 2	INTB#	INTC#	INTD#	INTA#

Chapter 3

BIOS Setup

This chapter provides information on the BIOS Setup program and allows you to configure the system for optimum use.

You may need to run the Setup program when:

- ≈ An error message appears on the screen during the system booting up, and requests you to run SETUP.
- ≈ You want to change the default settings for customized features.

Entering Setup

Power on the computer and the system will start POST (Power On Self Test) process. When the message below appears on the screen, press key to enter Setup.

Press DEL to enter SETUP

If the message disappears before you respond and you still wish to enter Setup, restart the system by turning it OFF and On or pressing the RESET button. You may also restart the system by simultaneously pressing <Ctrl>, <Alt>, and <Delete> keys.



Important

1. The items under each BIOS category described in this chapter are under continuous update for better system performance. Therefore, the description may be slightly different from the latest BIOS and should be held for reference only.
2. Upon boot-up, the 1st line appearing after the memory count is the BIOS version. It is usually in the format:

A7501AMS V1.0 011508 where:

1st digit refers to BIOS maker as A = AMI, W = AWARD, and P = PHOENIX.

2nd - 5th digit refers to the model number.

6th digit refers to the chipset as I = Intel, N = nVidia, A = AMD and V = VIA.

7th - 8th digit refers to the customer as MS = all standard customers. V1.0 refers to the BIOS version.

011508 refers to the date this BIOS was released.

Control Keys

<↑>	Move to the previous item
<↓>	Move to the next item
<←>	Move to the item in the left hand
<→>	Move to the item in the right hand
<Enter>	Select the item
<Esc>	Jumps to the Exit menu or returns to the main menu from a submenu
<+/PU>	Increase the numeric value or make changes
<-/PD>	Decrease the numeric value or make changes
<F6>	Load Optimized Defaults
<F7>	Load Fail-Safe Defaults
<F10>	Save configuration changes and exit setup

Getting Help

After entering the Setup menu, the first menu you will see is the Main Menu.

Main Menu

The main menu lists the setup functions you can make changes to. You can use the arrow keys (↑↓) to select the item. The on-line description of the highlighted setup function is displayed at the bottom of the screen.

Sub-Menu

If you find a right pointer symbol (as shown in the right view) appears to the left of certain fields that means a sub-menu can be launched from this field. A sub-menu contains additional options for a field parameter. You can use arrow keys (↑↓) to highlight the field and press <Enter> to call up the sub-menu. Then you can use the control keys to enter values and move from field to field within a sub-menu. If you want to return to the main menu, just press the <Esc >.

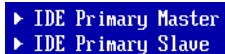

```

▶ IDE Primary Master
▶ IDE Primary Slave

```

General Help <F1>

The BIOS setup program provides a General Help screen. You can call up this screen from any menu by simply pressing <F1>. The Help screen lists the appropriate keys to use and the possible selections for the highlighted item. Press <Esc> to exit the Help screen.

The Main Menu

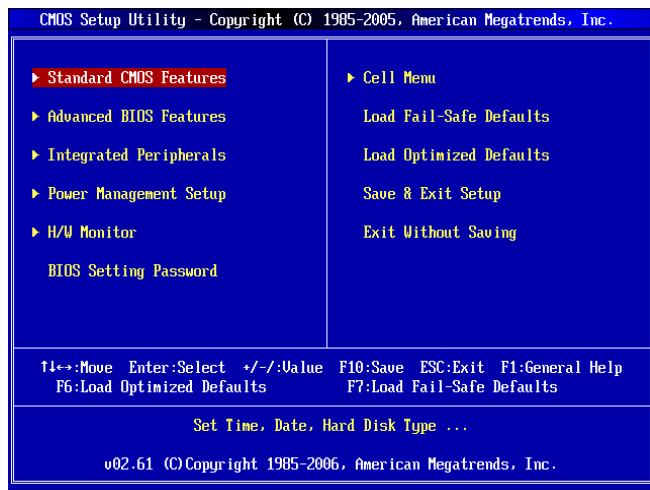

► Standard CMOS Features

Use this menu for basic system configurations, such as time, date etc.

► Advanced BIOS Features

Use this menu to setup the items of AMI® special enhanced features.

► Integrated Peripherals

Use this menu to specify your settings for integrated peripherals.

► Power Management Setup

Use this menu to specify your settings for power management.

► H/W Monitor

This entry shows your PC health status.

► Cell Menu

Use this menu to specify your settings for frequency/voltage control and overclocking.

► Load Fail-Safe Defaults

Use this menu to load the default values set by the BIOS vendor for stable system performance.

▶ **Load Optimized Defaults**

Use this menu to load the default values set by the mainboard manufacturer specifically for optimal performance of the mainboard.

▶ **BIOS Setting Password**

Use this menu to set the password for BIOS.

▶ **Save & Exit Setup**

Save changes to CMOS and exit setup.

▶ **Exit Without Saving**

Abandon all changes and exit setup.

Standard CMOS Features

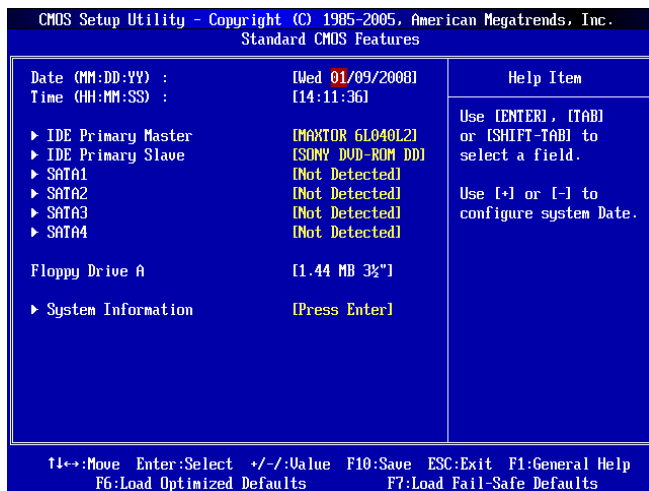

▶ Date (MM:DD:YY)

This allows you to set the system to the date that you want (usually the current date). The format is <day> <month> <date> <year>.

day	Day of the week, from Sun to Sat, determined by BIOS. Read-only.
month	The month from Jan. through Dec.
date	The date from 1 to 31 can be keyed by numeric function keys.
year	The year can be adjusted by users.

▶ Time (HH:MM:SS)

This allows you to set the system time that you want (usually the current time). The time format is <hour> <minute> <second>.

► IDE Primary Master/Slave, SATA1/2/3/4



Important

The IDE Primary Master/Slave, SATA1/2/3/4 items appear when you connect hard disk drives to the IDE/SATA connector on the mainboard.

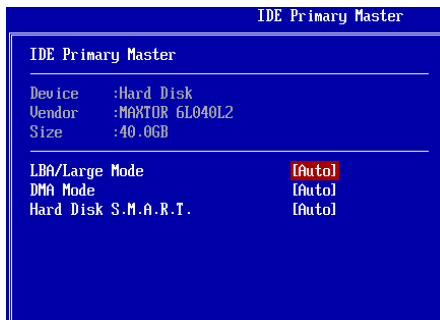

► Device, Vendor, Size

These settings show the IDE/SATA device information. Read only.

► LBA/Large Mode

This setting allows you to enable or disable the LBA Mode. Setting to [Auto] enables LBA mode if the device supports it and has not been formatted with LBA mode disabled.

► DMA Mode

This setting specifies the DMA Mode.

► Hard Disk S.M.A.R.T.

This setting allows you to activate the S.M.A.R.T. (Self-Monitoring Analysis & Reporting Technology) capability for the hard disk drives. S.M.A.R.T is a utility that monitors your disk status to predict hard disk failure. This gives you an opportunity to move data from a hard disk that is going to fail to a safe place before the hard disk becomes off-line.

► Floppy Drive A

This setting allows you to set the type of floppy drives installed.

► System Information

```
System Information
AMD Phenom(tm) 9500 Quad-Core Processor
CPUID/MicroCode 0100F22h/01000035h
CPU Frequency 2200MHz
BIOS Version U1.0B8 010908
Physical Memory 1024MB
Cache Size 2048KB
L3 Cache Size 2048KB
```

► CPU ID/MicroCode, CPU Frequency, BIOS Version, Physical Memory, Cache Size, L3 Cache Size

These items show the CPU information, BIOS version and memory status of your system (read only).

Advanced BIOS Features

CMOS Setup Utility - Copyright (C) 1985-2005, American Megatrends, Inc.		
Advanced BIOS Features		
Full Screen Logo Display	[Enabled]	Help Item
Quick Booting	[Enabled]	
Boot Up Num-Lock LED	[On]	Disabled: Displays normal POST messages.
IOAPIC Function	[Enabled]	Enabled: Displays OEM Logo instead of POST messages.
MPS Table Version	[1.4]	
Password Check	[BIOS]	
Primary Graphic's Adapter	[Internal]	
PCI Latency Timer	[64]	
▶ CPU Feature	[Press Enter]	
▶ Chipset Feature	[Press Enter]	
▶ Boot Sequence	[Press Enter]	
▶ Trusted Computing	[Press Enter]	

↑↓:Move Enter:Select +/-:Value F10:Save ESC:Exit F1:General Help
F8:Fail-Safe Defaults F6:Optimized Defaults

► Full Screen Logo Display

This item enables you to show the company logo on the bootup screen. Settings are:

[Enabled]	Shows a still image (logo) on the full screen at boot.
[Disabled]	Shows the POST messages at boot.

► Quick Booting

Setting the item to [Enabled] allows the system to boot within 5 seconds since it will skip some check items.

► Boot Up Num-Lock LED

This setting is to set the Num Lock status when the system is powered on. Setting to [On] will turn on the Num Lock key when the system is powered on. Setting to [Off] will allow users to use the arrow keys on the numeric keypad.

► IOAPIC Function

This field is used to enable or disable the APIC (Advanced Programmable Interrupt Controller). Due to compliance with PC2001 design guide, the system is able to run in APIC mode. Enabling APIC mode will expand available IRQ resources for the system.

► MPS Table Version

This field allows you to select which MPS (Multi-Processor Specification) version to be used for the operating system. You need to select the MPS version supported by your operating system. To find out which version to use, consult the vendor of your operating system.

► Password Check

This setting appears only when the **BIOS Setting Password** (p. 3-23) has been set beforehand. It specifies the type of BIOS password protection that is implemented. When set to [System], the password is required both at boot and at entry to Setup. If set to [BIOS], password prompt only occurs when you try to enter Setup.

► Primary Graphic's Adapter

This setting specifies which graphic card is your primary graphics adapter.

► PCI Latency Timer

This item controls how long each PCI device can hold the bus before another takes over. When set to higher values, every PCI device can conduct transactions for a longer time and thus improve the effective PCI bandwidth. For better PCI performance, you should set the item to higher values.

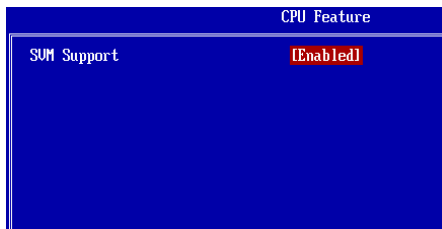
► CPU Feature**► SVM Support**

SVM (Secure Virtual Machine) technology provides a set of hardware extensions designed to enable economical and efficient implementation of virtual machine systems. Generally speaking, hardware support falls into two complementary categories: *virtualization* support and *security* support. Not all processors support SVM.

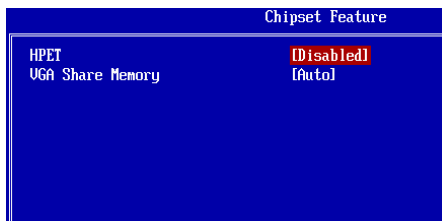
► Chipset Feature**► HPET**

The High Precision Event Timer (HPET) was developed jointly by Intel and Microsoft to meet the timing requirements of multimedia and other time-sensitive applications.

In addition to extending the capabilities and precision of a system, the HPET also improves system performance.

► VGA Share Memory

The system shares memory to the onboard VGA card. This setting controls the exact memory size shared to the VGA card.

► Boot Sequence

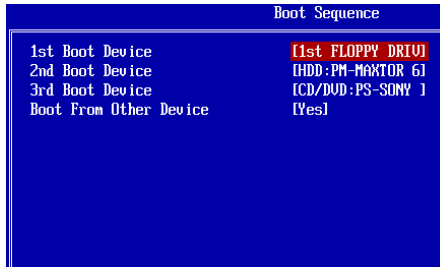

► 1st/2nd/3rd Boot Device

The items allow you to set the first boot device where BIOS attempts to load the disk operating system.

► Boot From Other Device

Setting the option to [Yes] allows the system to try to boot from other device. if the system fails to boot from the 1st boot device.

► Trusted Computing

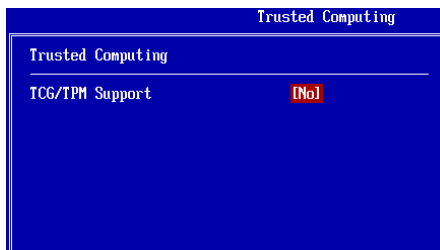

► TCG/TPM Support

This setting controls the Trusted Platform Module (TPM) designed by the Trusted Computing Group (TCG). TPMs are special-purpose integrated circuits (ICs) built into a variety of platforms to enable strong user authentication and machine attestation—essential to prevent inappropriate access to confidential and sensitive information and to protect against *compromised networks*. TPM Services is now a new feature set in Windows Server "Longhorn" and Windows Vista.

Integrated Peripherals

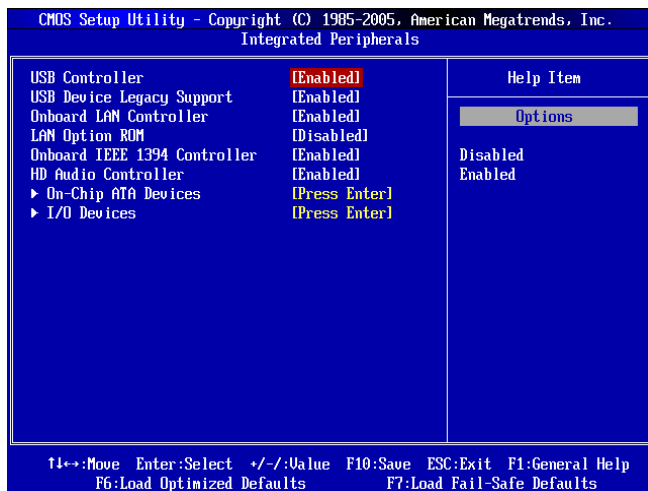

► USB Controller

This setting allows you to enable/disable the onboard USB 1.1/ 2.0 controller.

► USB Device Legacy Support

Set to [Enabled] if you need to use any USB 1.1/2.0 device in the operating system that does not support or have any USB 1.1/2.0 driver installed, such as DOS and SCO Unix. Set to [Disabled] only if you want to use any USB device other than the USB mouse.

► Onboard LAN Controller

This setting allows you to enable/disable the onboard LAN controller.

► LAN Option ROM

The items enable or disable the initialization of the onboard LAN Boot ROM during bootup. Selecting [Disabled] will speed up the boot process.

► Onboard IEEE1394 Controller (Optional)

This item allows you to enable/disable the onboard IEEE1394 controller.

► HD Audio Controller

This setting is used to enable/disable the High Definition Audio interface.

► On-Chip ATA Devices**► PCI IDE BusMaster**

Set this option to [Enabled] to specify that the IDE controller on the PCI local bus has bus mastering capability.

► On-Chip SATA Controller

This item allows users to enable or disable the SATA controller.

► RAID Mode

This item is used to enable/disable the RAID function for SATA devices.

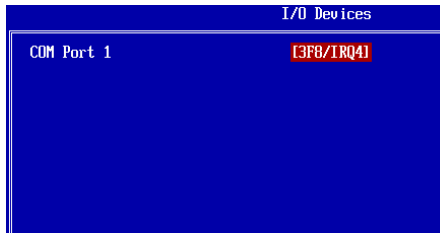
► I/O Devices**► COM Port 1**

This setting specifies the base I/O port address and IRQ resource of the onboard serial port.

Power Management Setup

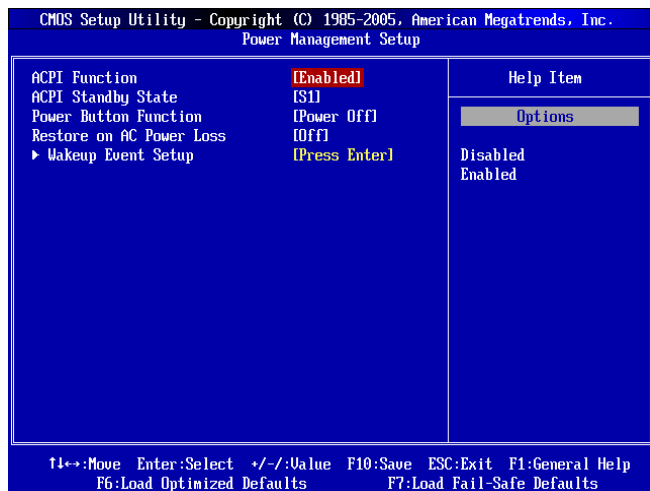

Important

S3-related functions described in this section are available only when your BIOS supports S3 sleep mode.

► ACPI Function

This item is to activate the ACPI (Advanced Configuration and Power Management Interface) Function. If your operating system is ACPI-aware, such as Windows 98SE/ 2000/ME/ XP, select [Enabled].

► ACPI Standby State

This item specifies the power saving modes for ACPI function. If your operating system supports ACPI, such as Windows 2000/ XP, you can choose to enter the Standby mode in S1(POS) or S3(STR) fashion through the setting of this field. Settings are:

- [S1] The S1 sleep mode is a low power state. In this state, no system context is lost (CPU or chipset) and hardware maintains all system context.
- [S3] The S3 sleep mode is a lower power state where the information of system configuration and open applications/files

is saved to main memory that remains powered while most other hardware components turn off to save energy. The information stored in memory will be used to restore the system when a “wake up” event occurs.

► **Power Button Function**

This feature sets the function of the power button. Settings are:

- [Power On/Off] The power button functions as normal power on/off button.
- [Suspend] When you press the power button, the computer enters the suspend/sleep mode, but if the button is pressed for more than four seconds, the computer is turned off.

► **Restore on AC Power Loss**

This item specifies whether your system will reboot after a power failure or interrupt occurs. Settings are:

- [Off] Always leaves the computer in the power off state.
- [On] Always leaves the computer in the power on state.
- [Last State] Restores the system to the status before power failure or interrupt occurred.

► **Wakeup Event Setup**

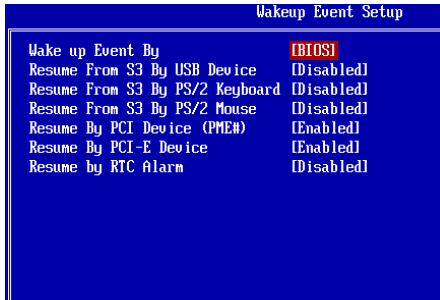

► **Wake Up Event By**

You can turn On or Off monitoring of commonly used interrupt requests so they do not awaken the system from, or reset activity timers for, Doze and Standby modes. For example, if you have a modem on IRQ3, you can turn On IRQ3 as a wake-up event, so an interrupt from the modem can wake up the system. Or you may wish to turn Off IRQ12 (the PS/2) mouse as a wake-up event, so accidentally brushing the mouse does not awaken the system.

► **Resume From S3 By USB Device**

The item allows the activity of the USB device to wake up the system from S3 (Suspend to RAM) sleep state.

▶ Resume From S3 By PS/2 Keyboard

This controls how the PS/2 keyboard is able to power on the system. If you choose *Specific Key*, the power button on the case will not function any more and you must type the password to power on the system.

▶ Resume from S3 By PS/2 Mouse

This setting determines whether the system will be awakened from what power saving modes when input signal of the PS/2 mouse is detected.

▶ Resume By PCI Device (PME#)

When set to [Enabled], the feature allows your system to be awakened from the power saving modes through any event on PME (Power Management Event).

▶ Resume By PCI-E Device

When set to [Enabled], the feature allows your system to be awakened from the power saving modes through any event on PCIE device.

▶ Resume By RTC Alarm

The field is used to enable or disable the feature of booting up the system on a scheduled time/date.

H/W Monitor

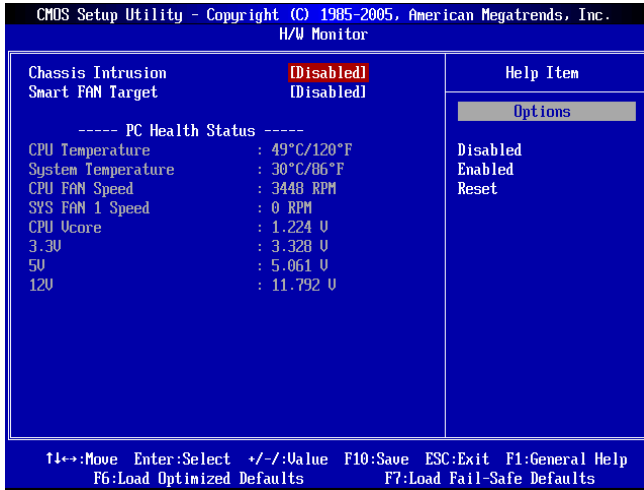

► Chassis Intrusion

The field enables or disables the feature of recording the chassis intrusion status and issuing a warning message if the chassis is once opened. To clear the warning message, set the field to [Reset]. The setting of the field will automatically return to [Enabled] later.

► Smart FAN Target

The mainboard provides the Smart Fan function which can control the CPU fan speed automatically depending on the current temperature to keep it within a specific range. You can select a fan target value here. If the current CPU fan temperature reaches to the target value, the smart fan function will be activated. It provides several sections to speed up for cooling down automatically .

► PC Health Status

► CPU/System Temperature, CPU FAN/SYS FAN1 Speed, CPU Vcore, 3.3V, 5V, 12V

These items display the current status of all of the monitored hardware devices/ components such as CPU voltage, temperatures and all fans' speeds.

Cell Menu

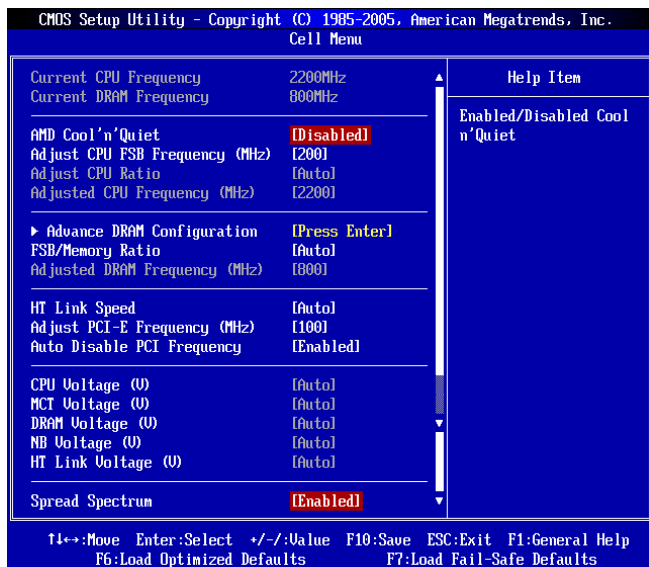

Important

Change these settings only if you are familiar with the chipset.

► **Current CPU / DRAM Frequency**

These items show the current clocks of CPU and Memory frequency. Read only.

► **AMD Cool'n'Quiet**

The Cool'n'Quiet technology can effectively and dynamically lower CPU speed and power consumption.



Important

To ensure that Cool'n'Quiet function is activated and will be working properly, it is required to double confirm that:

1. Run BIOS Setup, and select **Cell Menu**. Under **Cell Menu**, find **AMD Cool'n'Quiet**, and set this item to "Enabled."
2. Enter Windows, and select [Start]-> [Settings]-> [Control Panel]-> [Power Options]. Enter **Power Options Properties** tag, and select **Minimal Power Management** under **Power schemes**.

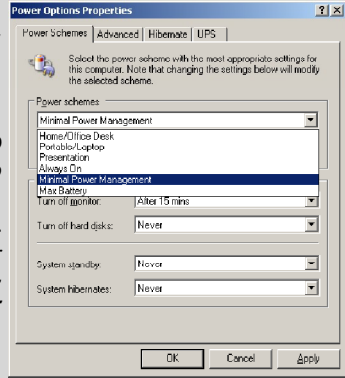

► **Adjust CPU FSB Frequency (MHz)**

This item allows you to set the CPU FSB frequency (in MHz).

► **Adjust CPU Ratio**

This item allows you to set the CPU ratio.

► **Adjusted CPU Frequency (MHz)**

It shows the adjusted CPU frequency (FSB x Ratio). Read only.

► Advance DRAM Configuration

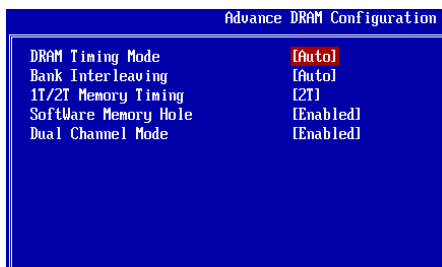

► DRAM Timing Mode

Setting to [Auto] enables DRAM CAS# Latency automatically to be determined by BIOS based on the configurations on the SPD (Serial Presence Detect) EEPROM on the DRAM module.

► Bank Interleaving

This field selects 2-bank or 4-bank interleave for the installed SDRAM. Disable the function if 16MB SDRAM is installed.

► 1T/2T Memory Timing

This field controls the SDRAM command rate. Selecting [1T] makes SDRAM signal controller to run at 1T (T=clock cycles) rate. Selecting [2T] makes SDRAM signal controller run at 2T rate.

► Software Memory Hole

This field enables software to remap the physical memory to the address higher than 00E0. (This item only works in 64-bit OS.)

► Dual Channel Mode

In Dual-Channel mode, the memory modules can transmit and receive data with two data bus lines simultaneously. Enabling Dual-Channel mode can enhance the system performance.

► FSB/Memory Ratio

This item will allow you to adjust the FSB/Ratio of the memory.

► Adjusted DRAM Frequency (MHz)

It shows the adjusted DDR memory frequency. Read only.

► HT Link Speed

This item allows you to set the Hyper Transport link speed.

► Adjust PCI-E Frequency (MHz)

This item allows you to set the PCI Express frequency (in MHz).

► Auto Disable PCI Frequency

When set to [Enabled], the system will remove (turn off) clocks from empty PCI slots to minimize the electromagnetic interference (EMI).

► CPU Voltage (V), MCT Voltage (V), DRAM Voltage (V), NB Voltage (V), HT Link Voltage (V)

These items display the power status of CPU, Memory, FSB and chipset. Read only.

► Spread Spectrum

When the motherboard's clock generator pulses, the extreme values (spikes) of the pulses create EMI (Electromagnetic Interference). The Spread Spectrum function reduces the EMI generated by modulating the pulses so that the spikes of the pulses are reduced to flatter curves. If you do not have any EMI problem, leave the setting at Disabled for optimal system stability and performance. But if you are plagued by EMI, set to Enabled for EMI reduction. Remember to disable Spread Spectrum if you are overclocking because even a slight jitter can introduce a temporary boost in clock speed which may just cause your overclocked processor to lock up.

**Important**

- 1. If you do not have any EMI problem, leave the setting at [Disabled] for optimal system stability and performance. But if you are plagued by EMI, select the value of Spread Spectrum for EMI reduction.*
- 2. The greater the Spread Spectrum value is, the greater the EMI is reduced, and the system will become less stable. For the most suitable Spread Spectrum value, please consult your local EMI regulation.*
- 3. Remember to disable Spread Spectrum if you are overclocking because even a slight jitter can introduce a temporary boost in clock speed which may just cause your overclocked processor to lock up.*

Load Fail-Safe / Optimized Defaults

The two options on the main menu allow users to restore all of the BIOS settings to the default Fail-Safe or Optimized values. The Optimized Defaults are the default values set by the mainboard manufacturer specifically for optimal performance of the mainboard. The Fail-Safe Defaults are the default values set by the BIOS vendor for stable system performance.

When you select Load Fail-Safe Defaults, a message as below appears:



Selecting Ok and pressing <Enter> loads the BIOS default values for the most stable, minimal system performance.

When you select Load Optimized Defaults, a message as below appears:

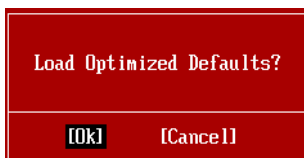

Selecting Ok and pressing <Enter> loads the default factory settings for optimal system performance.

BIOS Setting Password

When you select this function, a message as below will appear on the screen:



Type the password, up to six characters in length, and press <Enter>. The password typed now will replace any previously set password from CMOS memory. You will be prompted to confirm the password. Retype the password and press <Enter>. You may also press <Esc> to abort the selection and not enter a password.

To clear a set password, just press <Enter> when you are prompted to enter the password. A message will show up confirming the password will be disabled. Once the password is disabled, the system will boot and you can enter Setup without entering any password.

When a password has been set, you will be prompted to enter it every time you try to enter Setup. This prevents an unauthorized person from changing any part of your system configuration.

Appendix A

Realtek ALC888 Audio

The Realtek ALC888 provides 10-channel DAC that simultaneously supports 7.1 sound playback and 2 channels of independent stereo sound output (multiple streaming) through the Front-Out-Left and Front-Out-Right channels.

Installing the Realtek HD Audio Driver

You need to install the driver for Realtek ALC888 codec to function properly before you can get access to 2-, 4-, 6-, 8- channel or 7.1+2 channel audio operations. Follow the procedures described below to install the drivers for different operating systems.

Installation for Windows 2000/ XP/ Vista

For Windows® 2000, you must install Windows® 2000 Service Pack4 or later before installing the driver. For Windows® XP, you must install Windows® XP Service Pack1 or later before installing the driver.

The following illustrations are based on Windows® XP environment and could look slightly different if you install the drivers in different operating systems.

1. Insert the application CD into the CD-ROM drive. The setup screen will automatically appear.
2. Click **Realtek HD Audio Driver**.

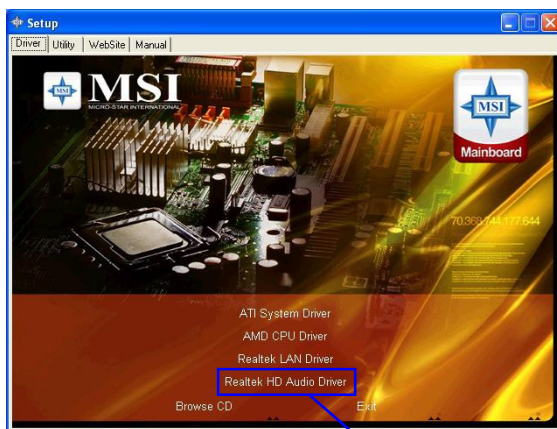

Click here



Important

The **HD Audio Configuration**  software utility is under continuous update to enhance audio applications. Hence, the program screens shown here in this section may be slightly different from the latest software utility and shall be held for reference only.

3. Click **Next** to install the Realtek High Definition Audio Driver.

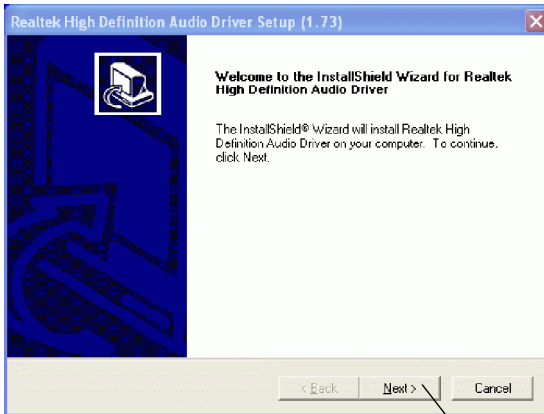

Click here

4. Click **Finish** to restart the system.

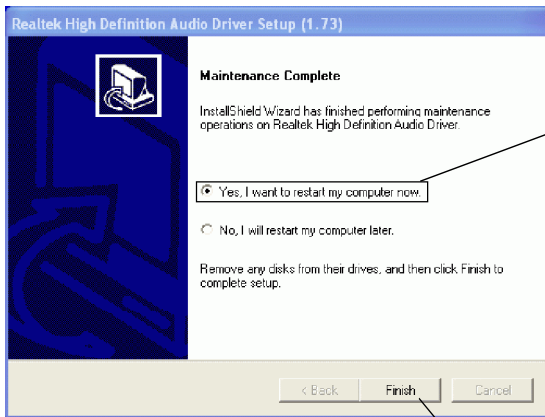

Select this option

Click here

Software Configuration

After installing the audio driver, you are able to use the 2-, 4-, 6- or 8- channel audio feature now. Click the audio icon  from the system tray at the lower-right corner of the screen to activate the **HD Audio Configuration**. It is also available to enable the audio driver by clicking the **Realtek HD Audio Manager** from the **Control Panel**.



Double click

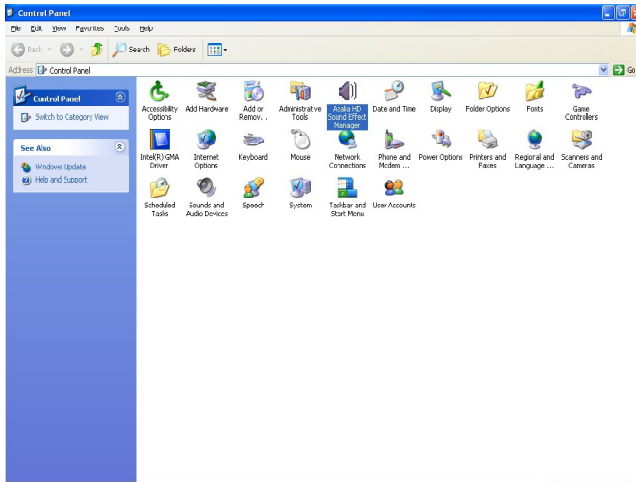

Sound Effect

Here you can select a sound effect you like from the **Environment** list.

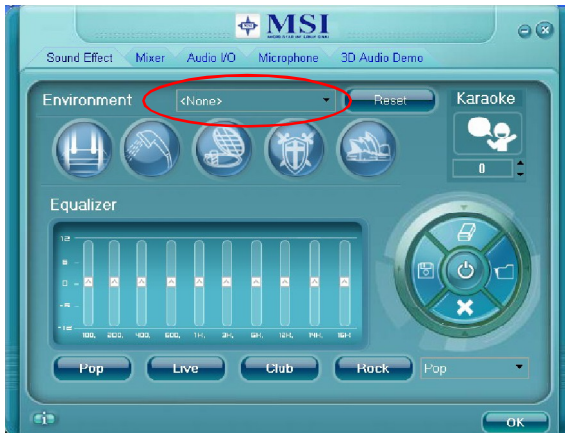

Environment Simulation

You will be able to enjoy different sound experience by pulling down the arrow, totally 23 kinds of sound effect will be shown for selection. Realtek HD Audio Sound Manager also provides five popular settings “Stone Corridor”, “Bathroom”, “Sewer pipe”, “Arena” and “Audio Corridor” for quick enjoyment.

You may choose the provided sound effects, and the equalizer will adjust automatically. If you like, you may also load an equalizer setting or make an new equalizer setting to save as an new one by using the “**Load EQ Setting**” and “**Save Preset**” button, click “**Reset EQ Setting**” button to use the default value, or click “**Delete EQ Setting**” button to remove a preset EQ setting.

There are also other pre-set equalizer models for you to choose by clicking “**Others**” under the **Equalizer** part.

Equalizer Selection

Equalizer frees users from default settings; users may create their own preferred settings by utilizing this tool.

10 bands of equalizer, ranging from 100Hz to 16KHz.

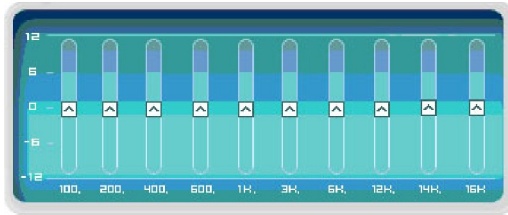

Save

The settings are saved permanently for future use

Reset

10 bands of equalizer would go back to the default setting

Enable / Disable

To disable, you can temporarily stop the sound effect without losing the settings

Load

Whenever you would like to use preload settings, simply click this, the whole list will be shown for your selection.

Delete

To delete the pre-saved settings which are created from previous steps.



Frequently Used Equalizer Setting

Realtek recognizes the needs that you might have. By leveraging our long experience at audio field, Realtek HD Audio Sound Manager provides you certain optimized equalizer settings that are frequently used for your quick enjoyment.

[How to Use It]

Other than the buttons “Pop” “Live” “Club” & “Rock” shown on the page, to pull down the arrow in “Others”, you will find more optimized settings available to you.

Karaoke Mode

Karaoke mode brings Karaoke fun back home. Simply using the music you usually play, Karaoke mode can help you eliminate the vocal of the song or adjust the key to accommodate your range.

- 1.Vocal Cancellation: Single click on “Voice Cancellation”, the vocal of the song would be eliminated, while the background music is still in place, and you can be that singer!
- 2.Key Adjustment: Using “Up / Down Arrow” to find a key which better fits your vocal range.

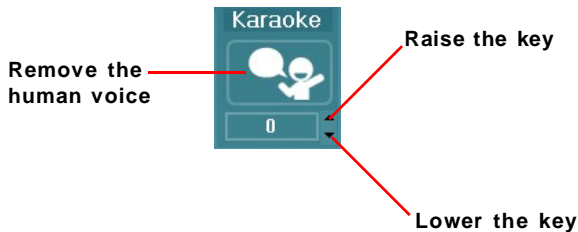

Mixer

In the **Mixer** part, you may adjust the volumes of the rear and front panels individually.

1. Adjust Volume

You can adjust the volume of the speakers that you plugged in front or rear panel by select the **Realtek HD Audio rear output** or **Realtek HD Audio front output** items.



Important

*Before set up, please make sure the playback devices are well plugged in the jacks on the rear or front panel. The **Realtek HD Audio front output** item will appear after you plugging the speakers into the jacks on the front panel.*

2. Multi-Stream Function

ALC888 supports an outstanding feature called Multi-Stream, which means you may play different audio sources simultaneously and let them output respectively from the indicated real panel or front panel. This feature is very helpful when 2 people are using the same computer together for different purposes.

Click the  button and the Mixer **ToolBox** menu will appear. Then check the **Enable playback multi-streaming** and click **OK** to save the setup.



Important

*If you use **AC97 front panel**, the device have to be plugged into the jacks on the panel before enable the multi-stream function.*

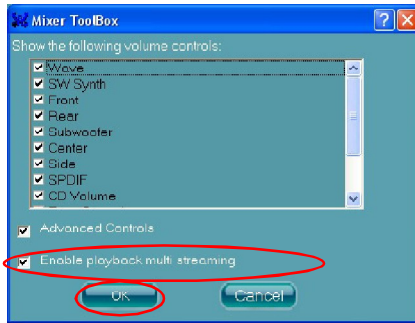

When you are playing the first audio source (for example: use Windows Media Player to play DVD/VCD), the output will be played from the rear panel, which is the default setting.

Then you **must** select the **Realtek HD Audio front output** from the scroll list **first**, and use a different program to play the second audio source (for example: use Winamp to play MP3 files). You will find that the second audio source (MP3 music) will come out from the Line-Out audio jack of Front Panel.



3. Playback control



Playback device

This function is to let you freely decide which ports to output the sound. And this is essential when multi-streaming playback enabled.

- Realtek HD Audio Rear Output
- Realtek HD Audio Front Output

Mute

You may choose to mute single or multiple volume controls or to completely mute sound output.

Tool

- Show the following volume controls

This is to let you freely decide which volume control items to be displayed.

- Advanced controls
- Enable playback multi-streaming

With this function, you will be able to have an audio chat with your friends via headphone (stream 1 from front panel) while still have music (stream 2 from back panel) in play. At any given period, you can have maximum 2 streams operating simultaneously.

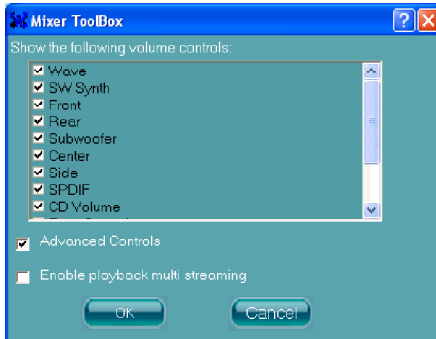

4. Recording control

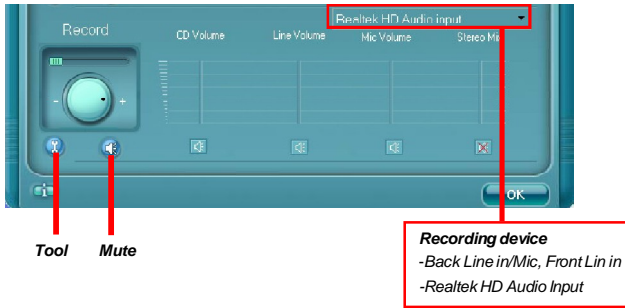

Mute

You may choose to mute single or multiple volume controls or to completely mute sound input.

Tool

- Show the following volume controls

This is to let you freely decide which volume control items to be displayed.

- Enable recording multi-streaming

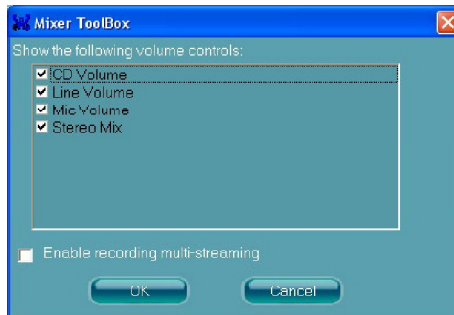

Important

ALC888 allows you to record the CD, Line, Mic and Stereo Mix channels simultaneously, frees you from mixing efforts. At any given period, you may choose 1 of the following 4 channels to record.

Audio I/O

In this tab, you can easily configure your multi-channel audio function and speakers. You can choose a desired multi-channel operation here.

- a. **Headphone** for the common headphone
- b. **2CH Speaker** for Stereo-Speaker Output
- c. **4CH Speaker** for 4-Speaker Output
- d. **6CH Speaker** for 5.1-Speaker Output
- e. **8CH Speaker** for 7.1-Speaker Output



Speaker Configuration:

1. Plug the speakers in the corresponding jack.
2. Dialogue “connected device” will pop up for your selection. Please select the device you have plugged in.
 - If the device is being plugged into the correct jack, you will be able to find the icon beside the jack changed to the one that is same as your device.
 - If not correct, Realtek HD Audio Manager will guide you to plug the device into the correct jack.

Connector Settings

Click  to access connector settings.



Disable front panel jack detection (option)

Find no function on front panel jacks? Please check if front jacks on your system are so-called AC'97 jacks. If so, please check this item to disable front panel jack detection.

Mute rear panel output when front headphone plugged in.

Enable auto popup dialogue, when device has been plugged in

Once this item checked, the dialog "Connected device" would automatically pop up when device plugged in.

S/PDIF

Short for Sony/Philips Digital Interface, a standard audio file transfer format. S/PDIF allows the transfer of digital audio signals from one device to another without having to be converted first to an analog format. Maintaining the viability of a digital signal prevents the quality of the signal from degrading when it is converted to analog.

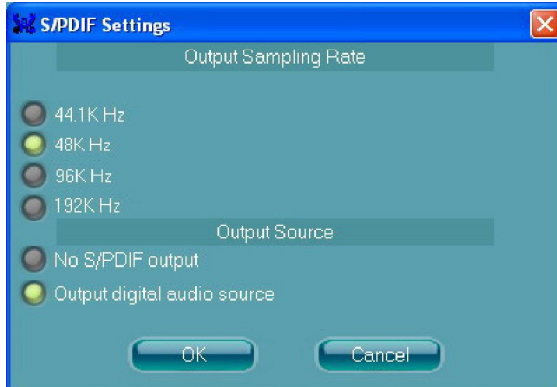

Output Sampling Rate

44.1KHz: This is recommend while playing CD.

48KHz: This is recommended while playing DVD or Dolby.

96KHz: This is recommended while playing DVD-Audio.

192KHz: This is recommended while playing High quality Audio.

Output Source

Output digital audio source: The digital audio format (such as .wav, .mp3,.midi etc) will come out through S/PDIF-Out.

Test Speakers

You can select the speaker by clicking it to test its functionality. The one you select will light up and make testing sound. If any speaker fails to make sound, then check whether the cable is inserted firmly to the connector or replace the bad speakers with good ones. Or you may click the **auto test**  button to test the sounds of each speaker automatically.

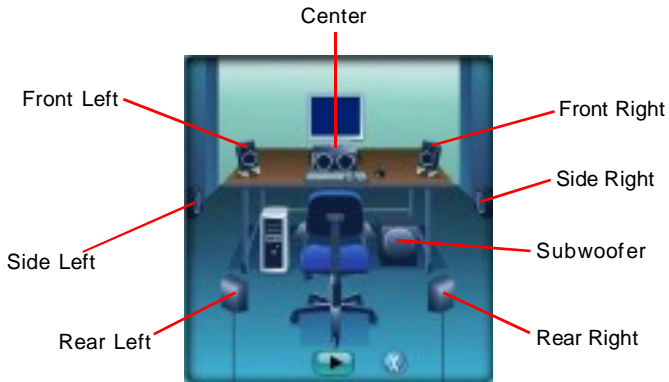

Microphone

In this tab you may set the function of the microphone. Select the **Noise Suppression** to remove the possible noise during recording, or select **Acoustic Echo Cancellation** to cancel the acoustic echo during recording.

Acoustic Echo Cancellation prevents playback sound from being recorded by microphone together with your sound. For example, you might have chance to use VOIP function through Internet with your friends. The voice of your friend will come out from speakers (playback). However, the voice of your friend might also be recorded into your microphone then go back to your friend through Internet. In that case, your friend will hear his/her own voice again. With AEC(Acoustic Echo Cancellation) enabled at your side, your friend can enjoy the benefit with less echo.



3D Audio Demo

In this tab you may adjust your 3D positional audio before playing 3D audio applications like gaming. You may also select different environment to choose the most suitable environment you like.



Information

In this tab it provides some information about this HD Audio Configuration utility, including Audio Driver Version, DirectX Version, Audio Controller & Audio Codec. You may also select the language of this utility by choosing from the **Language** list.



Also there is a selection **Show icon in system tray**. Switch it on and an icon  will show in the system tray. Right-click on the icon and the **Audio Accessories** dialogue box will appear which provides several multimedia features for you to take advantage of.



Hardware Setup

Connecting the Speakers

When you have set the Multi-Channel Audio Function mode properly in the software utility, connect your speakers to the correct phone jacks in accordance with the setting in software utility.

n 2-Channel Mode for Stereo-Speaker Output

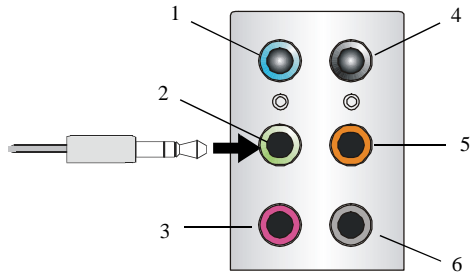

- 1 Line In
- 2 Line Out (*Front channels*)
- 3 MC
- 4 No function
- 5 No function
- 6 No function

n 4-Channel Mode for 4-Speaker Output

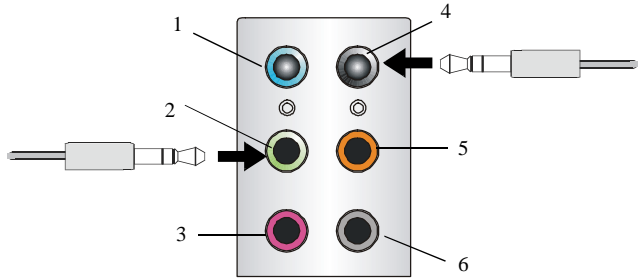

- 1 Line In
- 2 Line Out (*Front channels*)
- 3 MIC
- 4 Line Out (*Rear channels*)
- 5 No function
- 6 No function

n 6-Channel Mode for 6-Speaker Output

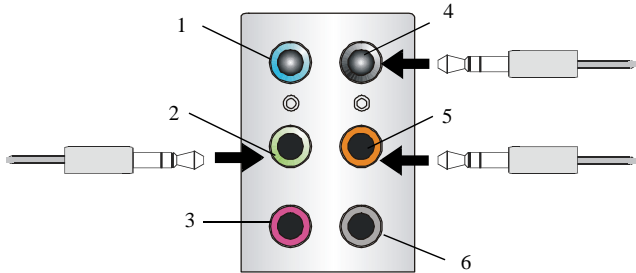

- 1 Line In
- 2 Line Out (*Front channels*)
- 3 MIC
- 4 Line Out (*Rear channels*)
- 5 Line Out (*Center and Subwoofer channel*)
- 6 No function

n 8-Channel Mode for 8-Speaker Output

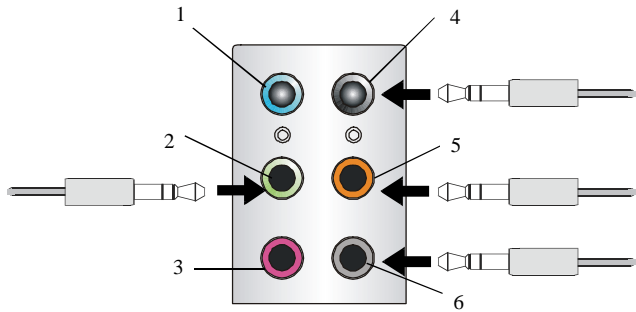

- 1 Line In
- 2 Line Out (Front channels)
- 3 MIC
- 4 Line Out (Rear channels)
- 5 Line Out (Center and Subwoofer channel)
- 6 Line Out (Side channels)



Important

To enable 7.1 channel audio-out function on Vista operating system, you have to install the Realtek Audio Driver. Or, the mainboard will support 5.1 channel audio-out only.

Appendix B

SATA RAID

The Southbridge integrates SATA host controller that supports four SATA ports and RAID function for performance and reliability.

SATA RAID provides support for RAID 0 (Striping), RAID 1 (Mirroring), RAID 0+1 (Striping & Mirroring). RAID 0 greatly improves hard disk I/O performance by concurrently striping data across multiple drives. RAID 1 makes sure data is not lost if a drive fails as data is simultaneously written to two drives. Drives configured for RAID Striping are said to form a RAID 0 set, while drives configured for RAID Mirroring are said to form a RAID 1 set. RAID 0+1 is implemented as a mirrored array whose segments are RAID 0 arrays. RAID 0+1 has same fault tolerance as mirroring and reduces overhead by striping. It needs at least four drives to form a RAID 0+1.

RAID Configuration

Creating and deleting RAID set and performing other RAID setting up operations are done in the RAID BIOS. During bootup, a screen similar to the one below will appear for about few seconds. Press <Ctrl-F> to enter the FastBuild utility.

RAID BIOS Version 2. 5. 1540. 33-A
(c) 2006 ATI Technology, Inc. All right reserved.

No Array is defined...

Press <Ctrl-F> to enter Fastbuild (tm) Utility



Important

Be sure to set the **SATA Mode** to "RAID" in BIOS (the path is : **Integrated Peripherals => On-Chip ATA Devices => OnChip SATA Controller**) before configuring the RAID BIOS.

The Fast Build Utility menu screen will appear. The Main Menu is used to choose the operation to be performed.



View Drives Assignments

This window displays the model number, capacities and assignment of the drives physically attached to the SATA host adapter.

Channel:ID	Drive Model	Capacity (MB)	Assignment
1: Mas	WDC WD800JD-00HKA0	80027	Free
	Extent 1	79960	
2: Mas	WDC WD800JD-00HKA0	80027	Free
	Extent 1	79960	

[Keys Available]

[↑] Up [↓] Down [ESC] Exit

Define LD (Creating RAID)

The selection of the RAID configuration should be based upon factors including performance, data security, and the number of drives available. It is best to carefully consider the long-term role of the system and plan the data storage strategy. RAID sets can be created either automatically, or to allow the greatest flexibility, manually.

1. Press **2** on the Main Menu screen to enter the Define LD Menu.
2. Press the arrow keys to highlight an logical drive number you want to define and press Enter to select it.

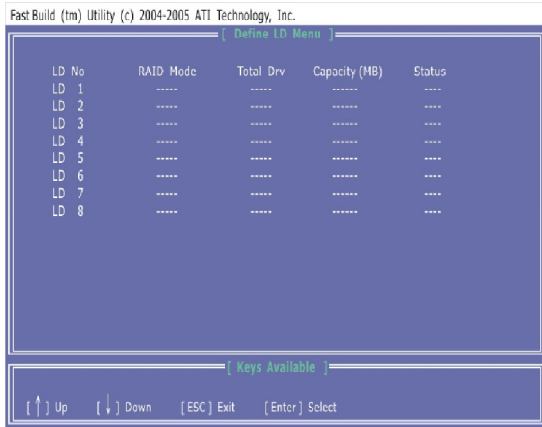

3. On the next screen, use the space key to choose a RAID mode (RAID 0/ 1/ 0+1) and use the arrow key to move to the *Drives Assignments* window.
 - Initialize logical drive, zero the disk drives. RAID 1 or 10 only.

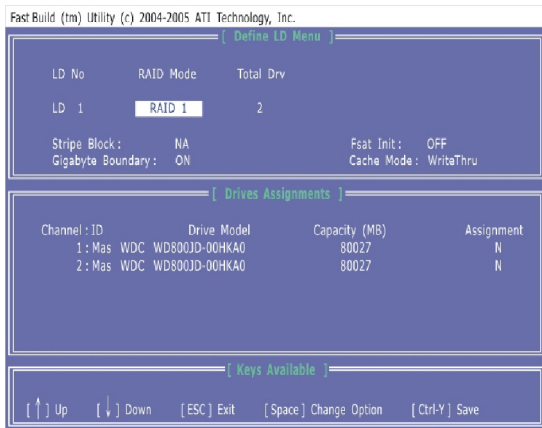

- Stripe Block Size, the default 64KB is best for most applications. RAID 0 or 10 only.
 - Gigabyte Boundary, allows use of slightly smaller replacement drives.
 - Cache Mode, WriteThru or WriteBack.
4. On the *Drives Assignments* window, use the arrow key to choose the hard drives which you want to make part of the LD, use the space key to change the assignment to “Y”. Then press [Ctrl+Y] to save the configuration.

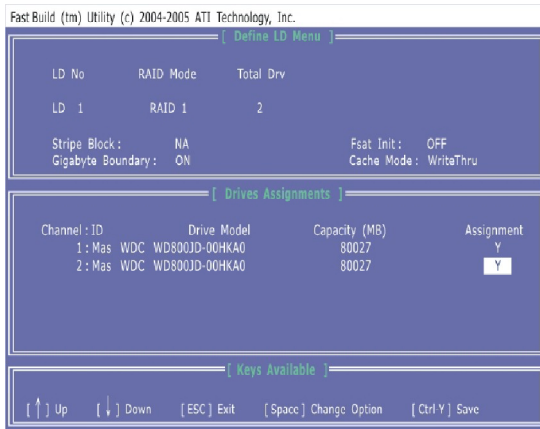

5. A message will show up on the bottom, press any key to save the configuration or press [Ctrl-Y] to allocate the RAID capacity manually.



Important

1. The default capacity is the full capacity of the selected hard drives.
2. If you allocate the first LD capacity manually, you can create second LD with remaining capacity of the selected hard drives.

MS-7501 Mainboard

6. The LD creation is done, the screen shows the LD information as below. Press ESC key to the main screen.

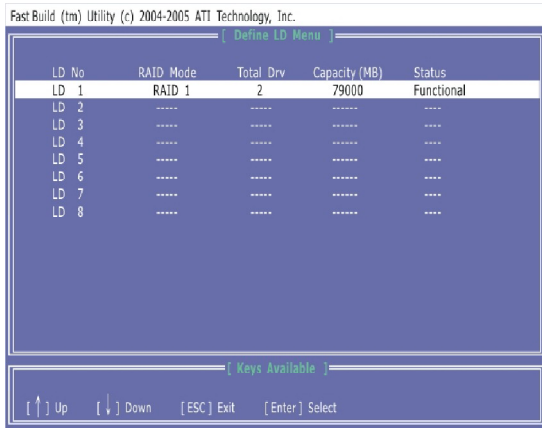

7. Press ESC key to exit the utility, a message “System is going to REBOOT! Are You Sure?” will display, answer “Y” to exit it and the system will reboot.

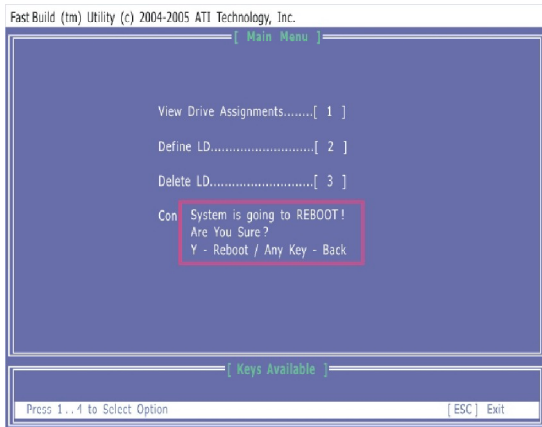

Delete LD (Deleting RAID)

1. Select "Delete LD" on the main screen.
2. Choose a LD No you want to delete and press "Del" or "Alt+D" delete the RAID set.

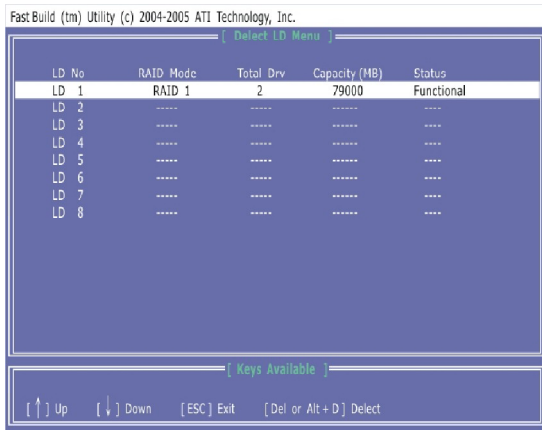

3. On the next screen, a message will display to inform you, press "Ctrl+Y" to delete the RAID set or other key to abort it. Press "Ctrl+Y" to complete the deletion.

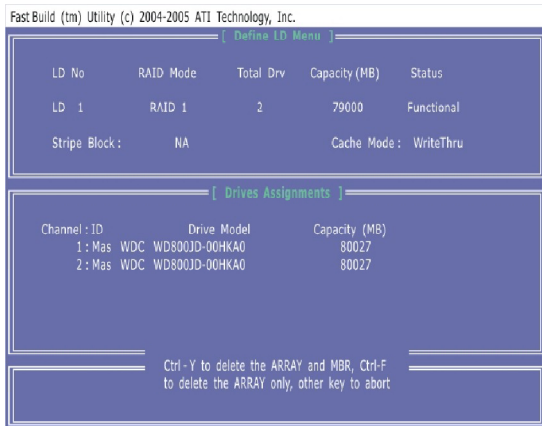

Installing the RAID Driver (for bootable RAID Array)

1. After you complete the RAID BIOS setup, boot from the Windows CD, and the Windows XP Setup program starts.
2. Press **F6** and wait for the Windows Setup screen to appear.



Important

Please follow the instruction below to make a SATA RAID driver for yourself.

1. Insert the MSI CD into the CD-ROM drive.
2. Click the "Browse CD" on the Setup screen.
3. Copy all the contents in the :
for Windows XP driver CD
ATI\ATIDrv\SBDrv\RAID
for Windows Vista driver CD
ChipSet\ATI\Packages\Drivers\SBDrv\RAID\X86 and
ChipSet\ATI\Packages\Drivers\SBDrv\RAID\X64 to a formatted floppy disk.
4. The driver disk for RAID controller is done.

3. Insert the floppy that contains the RAID driver, Press the "S" key to select "Specify Additional Device".
4. For Windows Vista:
During the Operating system installation, after selecting the location to install Vista click on "Load Driver" button to install a third party SCSI or RAID driver.
5. When prompted, insert the floppy disk or media (Floppy, CD/DVD Or USB) and press Enter.
6. You should be shown a list of available SCSI Adapters.
7. Select "**ATI AHCI Compatible RAID Controller -x86 platform**" when the system is 32-bit version or "**ATI AHCI Compatible RAID Controller -x64 platform**" when the system is 64-bit version and then press ENTER.
8. The next screen should confirm that you have selected the ATI RAID controller. Press ENTER again to continue.
9. You have successfully installed the ATI RAID driver, and Windows setup should continue.
10. Leave the disk in the floppy drive until the system reboots itself. Windows setup will need to copy the files from the floppy again after the RAID volume is formatted, and Windows setup starts copying files.

Installing the RAID Driver Under Windows (for Non-bootable RAID Array)

1. Insert the MSI CD into the CD-ROM drive.
2. The CD will auto-run and the setup screen will appear.
3. Under the Driver tab, click on **ATI System Driver**. The ATI System Driver includes RAID Driver.
4. The driver will be automatically installed.



Important

You **must** install the RAID driver to enable RAID.