

Preface

Copyright

This publication, including all photographs, illustrations and software, is protected under international copyright laws, with all rights reserved. Neither this manual, nor any of the material contained herein, may be reproduced without written consent of the author.

Version 1.0a

Disclaimer

The information in this document is subject to change without notice. The manufacturer makes no representations or warranties with respect to the contents hereof and specifically disclaims any implied warranties of merchantability or fitness for any particular purpose. The manufacturer reserves the right to revise this publication and to make changes from time to time in the content hereof without obligation of the manufacturer to notify any person of such revision or changes.

Trademark Recognition

Microsoft, MS-DOS and Windows are registered trademarks of Microsoft Corp.

MMX, Pentium, Pentium-II, Pentium-III, Celeron are registered trademarks of Intel Corporation.

Other product names used in this manual are the properties of their respective owners and are acknowledged.

Federal Communications Commission (FCC)

This equipment has been tested and found to comply with the limits for a Class B digital device, pursuant to Part 15 of the FCC Rules. These limits are designed to provide reasonable protection against harmful interference in a residential installation. This equipment generates, uses, and can radiate radio frequency energy and, if not installed and used in accordance with the instructions, may cause harmful interference to radio communications. However, there is no guarantee that interference will not occur in a particular installation. If this equipment does cause harmful interference to radio or television reception, which can be determined by turning the equipment off and on, the user is encouraged to try to correct the interference by one or more of the following measures:

- Reorient or relocate the receiving antenna.
- Increase the separation between the equipment and the receiver.
- Connect the equipment onto an outlet on a circuit different from that to which the receiver is connected.
- Consult the dealer or an experienced radio/TV technician for help.

Shielded interconnect cables and a shielded AC power cable must be employed with this equipment to ensure compliance with the pertinent RF emission limits governing this device. Changes or modifications not expressly approved by the system's manufacturer could void the user's authority to operate the equipment.

Declaration of Conformity

This device complies with part 15 of the FCC rules. Operation is subject to the following conditions:

- This device may not cause harmful interference, and
- This device must accept any interference received, including interference that may cause undesired operation.

Canadian Department of Communications

This class B digital apparatus meets all requirements of the Canadian Interference-causing Equipment Regulations.

Cet appareil numérique de la classe B respecte toutes les exigences du Règlement sur le matériel brouilleur du Canada.

About the Manual

The manual consists of the following:

Chapter 1 Introducing the Motherboard	Describes features of the motherboard, and provides a shipping checklist. Go to ⇒ page 1
Chapter 2 Installing the Motherboard	Describes installation of motherboard components. Go to ⇒ page 7
Chapter 3 Using BIOS	Provides information on using the BIOS Setup Utility. Go to ⇒ page 24
Chapter 4 Using the Motherboard Software	Describes the motherboard software. Go to ⇒ page 46

TABLE OF CONTENTS

Preface	i
Features Translations	v
CHAPTER 1	1
Introducing the Motherboard	1
<i>Introduction</i>	1
<i>Features</i>	2
<i>Choosing a Computer Case</i>	4
<i>Motherboard Components</i>	5
CHAPTER 2	7
Installing the Motherboard	7
<i>Safety Precautions</i>	7
<i>Quick Guide</i>	7
<i>Installing the Motherboard in a Case</i>	8
<i>Checking Jumper Settings</i>	8
Setting Jumpers	8
Checking Jumper Settings	9
Jumper Settings	9
<i>Connecting Case Components</i>	10
Front Panel Connector	12
<i>Installing Hardware</i>	13
Installing the Processor.....	13
Installing Memory Modules	16
Installing a Hard Disk Drive/CD-ROM.....	17
Installing a Floppy Diskette Drive.....	18
Installing Add-on Cards.....	19
Connecting Optional Devices.....	21
<i>Connecting I/O Devices</i>	23
CHAPTER 3	24
Using BIOS	24
<i>About the Setup Utility</i>	24
The Standard Configuration	24
Starting Setup	25
Updating the BIOS	26
<i>Using BIOS</i>	27
Standard CMOS Features	27
Advanced BIOS Features	29
Advanced Chipset Setup.....	32
Integrated Peripherals.....	34
Power Management Setup	38

PNP/PCI Configurations.....	41
PC Health Status.....	42
Frequency/Voltage Control.....	43
Load Fail-Safe Defaults Option.....	44
Load Optimized Defaults Option.....	44
Set Supervisor/User Password.....	44
Save & Exit Setup Option.....	45
Exit Without Saving.....	45

CHAPTER 4 **46**

Using the Motherboard Software	46
<i>About the Software CD-ROM</i>	46
<i>Auto-installing under Windows 98/ME/2000/XP</i>	46
Running Setup.....	47
<i>Manual Installation</i>	49
<i>Utility Software Reference</i>	49

Features Translations

Caractéristiques

Processeur	La carte mère utilise un Socket A de 462 broches AMD qui prend en charge un Bus Frontal (FSB) de 333/266/200 MHz, prenant en charge les CPU AMD Athlon XP/Sempron/Athlon /Duron avec FSB jusqu'à 333 MHz.						
Chipset	<p>Le chipset sur cette carte mère comprend le chipset SiS741GX Northbridge combiné avec le chipset SiS964L Southbridge. Le tableau ci-dessous explique brièvement certaines des caractéristiques avancées du chipset.</p> <table border="1" style="width: 100%; border-collapse: collapse;"> <thead> <tr> <th style="text-align: center;">Chipset</th> <th style="text-align: center;">Caractéristiques</th> </tr> </thead> <tbody> <tr> <td style="text-align: center; vertical-align: top;">SiS741GX NB</td> <td> Supporte les CPU AMD Athlon XP/ Sempron/ Athlon / Duron CPU avec FSB jusqu'à 333MHz Supporte les DDR 333/266 SDRAM Compatible avec AGP 3.0 Universel (supporte la carte 1.5V AGP seulement) Supporte l'interface AGP 8X/4X avec w/Fast Write Transaction Intègre un moteur 3D de haute qualité Supporte les registres de configuration de gestion d'alimentation PCI pour prendre en charge le contrôleur de coupure d'alimentation ACPI </td> </tr> <tr> <td style="text-align: center; vertical-align: top;">SiS964L SB</td> <td> Conforme aux spécifications PCI 2.3 Prend en charge les réseaux domestiques full duplex 10base-T, 100base-Tx, 1Mb/s & 10 Mb/s Conforme à AC' 97 v2.3 supportant 6 Canaux de sortie haut-parleur AC' 97 et Modem V.90 HSP Gestion d'Alimentation avancée. (Exigences ACPI 2.0 et exigences APM 1.2) </td> </tr> </tbody> </table> <p>Les caractéristiques clé supplémentaires incluent le support pour huit ports USB, contrôleur Fast Ethernet MAC, interface AC' 97, gestion d'alimentation avancée, contrôleur DMA et contrôleur de clavier intégrés.</p>	Chipset	Caractéristiques	SiS741GX NB	Supporte les CPU AMD Athlon XP/ Sempron/ Athlon / Duron CPU avec FSB jusqu'à 333MHz Supporte les DDR 333/266 SDRAM Compatible avec AGP 3.0 Universel (supporte la carte 1.5V AGP seulement) Supporte l'interface AGP 8X/4X avec w/Fast Write Transaction Intègre un moteur 3D de haute qualité Supporte les registres de configuration de gestion d'alimentation PCI pour prendre en charge le contrôleur de coupure d'alimentation ACPI	SiS964L SB	Conforme aux spécifications PCI 2.3 Prend en charge les réseaux domestiques full duplex 10base-T, 100base-Tx, 1Mb/s & 10 Mb/s Conforme à AC' 97 v2.3 supportant 6 Canaux de sortie haut-parleur AC' 97 et Modem V.90 HSP Gestion d'Alimentation avancée. (Exigences ACPI 2.0 et exigences APM 1.2)
Chipset	Caractéristiques						
SiS741GX NB	Supporte les CPU AMD Athlon XP/ Sempron/ Athlon / Duron CPU avec FSB jusqu'à 333MHz Supporte les DDR 333/266 SDRAM Compatible avec AGP 3.0 Universel (supporte la carte 1.5V AGP seulement) Supporte l'interface AGP 8X/4X avec w/Fast Write Transaction Intègre un moteur 3D de haute qualité Supporte les registres de configuration de gestion d'alimentation PCI pour prendre en charge le contrôleur de coupure d'alimentation ACPI						
SiS964L SB	Conforme aux spécifications PCI 2.3 Prend en charge les réseaux domestiques full duplex 10base-T, 100base-Tx, 1Mb/s & 10 Mb/s Conforme à AC' 97 v2.3 supportant 6 Canaux de sortie haut-parleur AC' 97 et Modem V.90 HSP Gestion d'Alimentation avancée. (Exigences ACPI 2.0 et exigences APM 1.2)						
Mémoire	<ul style="list-style-type: none"> • Peut recevoir deux logements sans mémoire tampon en 2.5V de 184 broches • Support de module mémoire DDR SDRAM jusqu'à 333/266 MHz • Chaque logement supporte jusqu'à 1 Go avec une capacité maximum totale de 2 Go 						
Graphiques	Cette carte mère inclut un logement AGP qui offre huit fois la bande passante des spécifications AGP d'origine. L'AGP 3.0 (8X AGP) offre une amélioration significative de performances accompagnée d'améliorations de fonctionnalités sur l'AGP2.0. Cette interface représente l'évolution naturelle de l'AGP existant.						

	tante pour répondre à une demande toujours croissante d'interfaces graphiques en environnements de station de travail et de bureau.
Audio	Le codec Audio AC' 97 est conforme aux spécifications AC' 97 2.3 répondant aux exigences PC2001 et supportant Sortie S/PDIF. Il possède aussi une mémoire tampon intégrée et PLL interne. Les fonctionnalités comprennent le support du commutateur analogique pour sortie arrière (partagée), la prise de ligne d'entrée (partagée), centre basse (partagée), et prise MIC à la sortie audio 6 canaux.
Options d'Extensions	La carte mère est livrée avec les options d'extensions suivantes: <ul style="list-style-type: none"> • Trois logements PCI 32 bits • Un slot conforme AGP 3.0 avec vitesse 8X/4X (supporte la carte 1.5V AGP seulement) • Un logement Communications Network Riser (CNR) (Interface AC' 97 seulement) • Deux connecteurs IDE supportant quatre lecteurs IDE • Une interface de lecteur de disquette pouvant supporter 2 lecteurs de disquettes Cette carte mère supporte la maîtrise de bus Ultra DMA avec des vitesses de transfert de 33/66/100/133 Mo/sec.
LAN Interne (optionnel)	Le LAN Interne est un Fast Ethernet Phyceiver avec interface MII sur puce MAC. Il offre les fonctionnalités suivantes: <ul style="list-style-type: none"> • Supporte l'interface MII • Supporte le fonctionnement en 10/100Mbps • Supporte le fonctionnement en half/full duplex • Fonctionnement en 3.3V avec signal 5V • Fonctionnement à faible consommation d'énergie
E/S Intégrées	La carte mère possède un jeu complet de ports d'E/S et de connecteurs: <ul style="list-style-type: none"> • Deux ports PS/2 pour souris et clavier • Un port série (COM1) • Un port VGA • Un port parallèle • Quatre ports USB • Un port LAN (optionnel) • Prises audio pour microphone, ligne d'entrée et ligne de sortie
Microprogramme BIOS	Cette carte mère utilise Award BIOS qui permet aux utilisateurs de configurer de nombreuses fonctionnalités du système comprenant les suivantes : <ul style="list-style-type: none"> • Gestion d'alimentation • Alarmes de réveil • Paramètres de CPU • Synchronisation de CPU et de mémoire Le microprogramme peut aussi être utilisé pour définir les paramètres pour les vitesses d'horloges de différents processeurs.



Certaines spécifications matérielles et éléments de logiciels peuvent être modifiés sans avertissement.

Funktionen

Prozessor	Das Motherboard ist mit einem AMD 462-Pin Socket ausgestattet, dass 333/266/200 MHz Front Side Bus (FSB) und AMD Athlon XP/Sempron/Athlon/Duron CPU mit FSB bis zu 333 MHz unterstützt.														
Chipsatz	<p>Der Chipsatz dieses Motherboards verfügt über die SiS741GX Northbridge, die mit der SiS964L Southbridge verbunden ist In der untenstehenden Tabelle werden einige der fortschrittlichen Funktionen des Chipsatzes kurz vorgestellt:</p> <table border="1"> <thead> <tr> <th><u>Chipsatz</u></th> <th><u>Funktionen</u></th> </tr> </thead> <tbody> <tr> <td rowspan="6">SiS741GX NB</td> <td>Unterstützt AMD Athlon XP/ Sempron /Athlon / Duron CPU mit FSB bis zu 333MHz</td> </tr> <tr> <td>Unterstützt DDR 333/266 SDRAM</td> </tr> <tr> <td>Entspricht Universal AGP v3.0 (unterstützt nur 1.5V AGP Interface)</td> </tr> <tr> <td>Unterstützt AGP 8X/4X-Interface mit Fast Write-Abwicklung</td> </tr> <tr> <td>Hochwertiger 3D-Engine integriert</td> </tr> <tr> <td>Unterstützung PCI-Power-Management-Konfigurationsregister zur Unterstützung eines ACPI Power Down-Controllers</td> </tr> <tr> <td rowspan="4">SiS964L SB</td> <td>Kompatibel mit der PCI 2.3-Spezifikation</td> </tr> <tr> <td>Unterstützung für Vollduplex 10base-T, 100base-Tx, 1Mb/Sek. & 10 Mb/Sek. Home-Networking</td> </tr> <tr> <td>Kompatibel mit AC' 97 v2.3; Unterstützung für sechst Kanäle für AC' 97-Lautsprecherausgänge sowie für ein V.90 HSP-Modem</td> </tr> <tr> <td>Advanced Power Management (ACPI 2.0-Anforderungen und APM 1.2-Anforderungen)</td> </tr> </tbody> </table> <p>Zusätzliche Schlüsseleigenschaften umfassen die Unterstützung für acht USB-Anschlüsse, Fast Ethernet MAC Controller, AC 97-Interface, Advanced Power Management, integrierter DMA Controller und Tastatur Controller.</p>	<u>Chipsatz</u>	<u>Funktionen</u>	SiS741GX NB	Unterstützt AMD Athlon XP/ Sempron /Athlon / Duron CPU mit FSB bis zu 333MHz	Unterstützt DDR 333/266 SDRAM	Entspricht Universal AGP v3.0 (unterstützt nur 1.5V AGP Interface)	Unterstützt AGP 8X/4X-Interface mit Fast Write-Abwicklung	Hochwertiger 3D-Engine integriert	Unterstützung PCI-Power-Management-Konfigurationsregister zur Unterstützung eines ACPI Power Down-Controllers	SiS964L SB	Kompatibel mit der PCI 2.3-Spezifikation	Unterstützung für Vollduplex 10base-T, 100base-Tx, 1Mb/Sek. & 10 Mb/Sek. Home-Networking	Kompatibel mit AC' 97 v2.3; Unterstützung für sechst Kanäle für AC' 97-Lautsprecherausgänge sowie für ein V.90 HSP-Modem	Advanced Power Management (ACPI 2.0-Anforderungen und APM 1.2-Anforderungen)
<u>Chipsatz</u>	<u>Funktionen</u>														
SiS741GX NB	Unterstützt AMD Athlon XP/ Sempron /Athlon / Duron CPU mit FSB bis zu 333MHz														
	Unterstützt DDR 333/266 SDRAM														
	Entspricht Universal AGP v3.0 (unterstützt nur 1.5V AGP Interface)														
	Unterstützt AGP 8X/4X-Interface mit Fast Write-Abwicklung														
	Hochwertiger 3D-Engine integriert														
	Unterstützung PCI-Power-Management-Konfigurationsregister zur Unterstützung eines ACPI Power Down-Controllers														
SiS964L SB	Kompatibel mit der PCI 2.3-Spezifikation														
	Unterstützung für Vollduplex 10base-T, 100base-Tx, 1Mb/Sek. & 10 Mb/Sek. Home-Networking														
	Kompatibel mit AC' 97 v2.3; Unterstützung für sechst Kanäle für AC' 97-Lautsprecherausgänge sowie für ein V.90 HSP-Modem														
	Advanced Power Management (ACPI 2.0-Anforderungen und APM 1.2-Anforderungen)														
Speicher	<ul style="list-style-type: none"> • Nimmt zwei ungepufferte 2.5V 184-Pin Steckplätze auf • Unterstützt DDR bis zu 333/266 MHz SDRAM-Speichermodul • Jeder Steckplatz unterstützt bis zu 1 GB mit einer maximalen Gesamtkapazität von bis zu 2 GB 														
Grafik	Das Motherboard enthält einen AGP-Steckplatz mit der achtfachen Bandbreite der ursprünglichen AGP-Spezifikation. AGP 3.0 (8XAGP) bietet gegenüber AGP2.0 eine erhebliche Leistungssteigerung und verbesserte Features. Dieses Interface stellt die natürliche Weiterentwicklung des bestehenden AGP dar, um den stetig anwachsenden Anforderungen an die Grafikschnittstellen innerhalb der Workstations und Desktop-Umgebungen gerecht zu werden.														
Audio	Der AC' 97 Audio-Codec entspricht der AC' 97 2.3-Spezifikation welche die PC2001-Anforderungen erfüllt und														

	S/PDIF Ausgang unterstützt. Er verfügt über einen eingebauten Puffer und internes PLL. Weitere Eigenschaften umfassen einen Analog-Schalter für den Hinterausgang (geteilt), Line-In Anschluss (geteilt), Center/Bass (geteilt) und einen Mikrofonstecker für 6 Kanal Audioausgabe.
Expansion Options	<p>Das Mainboard bietet die folgenden Erweiterungsoptionen:</p> <ul style="list-style-type: none"> • Drei 32-bit PCI-Steckplätze • Eine nach AGP 3.0-gemäße Schlitzeinrichtung mit einer Geschwindigkeit von 8X/4X (unterstützt nur 1.5V AGP Interface) • Einen Steckplatz für Communications Network Riser (CNR) (nur AC' 97-Interface) • Zwei IDE-Stecker, die vier IDE- Vorrichtungen • Eine Diskettenlaufwerk-Schnittstelle welche 2 FDD-Vorrichtungen unterstützen kann <p>Dieses Motherboard unterstützt Ultra DMA Bus-Mastering mit Übertragungsraten von 33/66/100/133 MB/s.</p>
Integriertes LAN (optional)	<p>Der Integriertes LAN ist ein Fast Ethernet Phyceiver mit einem MII-Interface und einem MAC-Chip. Er hat folgende Funktionen:</p> <ul style="list-style-type: none"> • Unterstützung für MII-Interface • Unterstützung für 10/100 Mbps/Sek.-Betrieb • Unterstützung für Halb-/Voll duplexbetrieb • 3.3 Volt-Betrieb mit 5 Volt-Signalen • Geringer Stromverbrauch beim Betrieb
Integrierte I/O	<p>Das Mainboard verfügt über einen kompletten Satz von I/O-Schnittstellen und Anschlüssen:</p> <ul style="list-style-type: none"> • Zwei PS/2-Schnittstellen für Maus und Tastatur • Eine serielle Schnittstelle (COM1) • Eine VGA Schnittstelle • Eine parallele Schnittstelle • Vier USB-Schnittstellen • Eine LAN-Schnittstelle (optional) • Audiobuchsen für Mikrofon, Line-in und Line-out
BIOS-Firmware	<p>Dieses Mainboard setzt das Award BIOS ein, mit dem der Anwender viele Systemeigenschaften selbst konfigurieren kann, einschließlich der folgenden:</p> <ul style="list-style-type: none"> • Energieverwaltung • Wake-up-Alarm • CPU-Parameter • CPU und Speichertiming <p>Mit der Firmware können auch die Parameter für verschiedene Prozessortaktgeschwindigkeiten eingestellt werden.</p>



Bestimmte Hardwarespezifikationen und Teile der Softwareausstattung können ohne weitere Ankündigung abgeändert werden.

Caratteristiche

Processore	La scheda madre utilizza una presa A a 462 pin AMD che supporta un Front Side Bus (FSB) da 333/266/200 MHz, compatibile con CPU AMD Athlon XP/Sempron/Athlon/Duron con FSB fino a 333 MHz.														
Chipset	<p>Il chipset è composto dai chipset Northbridge SiS741GX e Southbridge SiS964L. La tabella sottostante presenta una panoramica delle funzioni avanzate del chipset:</p> <table border="1"> <thead> <tr> <th>Chipset</th> <th>Caratteristiche</th> </tr> </thead> <tbody> <tr> <td rowspan="6">SiS741GX NB</td> <td>Vengono supportate le CPU AMD Athlon XP/Sempron/Athlon / Duron con FSB fino a 333MHz</td> </tr> <tr> <td>Supporta DDR 333/266 SDRAM</td> </tr> <tr> <td>Compliant with Universal AGP 3.0 (supporta solo l'interfaccia 1.5V AGP)</td> </tr> <tr> <td>Supporta l'interfaccia AGP 8X/4X con Funzione Transizione Fast Write</td> </tr> <tr> <td>Motore 3D integrato di altissima qualità</td> </tr> <tr> <td>Supporto per la gestione "Risparmio Energia" PCI garantendo la compatibilità con i controller ACPI</td> </tr> <tr> <td rowspan="4">SiS964L SB</td> <td>Conforme allo standard PCI 2.3</td> </tr> <tr> <td>Supporto home networking full duplex per 10base-T, 100base-Tx, 1Mb/s & 10 Mb/s</td> </tr> <tr> <td>Conforme allo standard AC' 97 v2.3 garantendo il supporto a 6 Canali delle uscite speaker AC' 97 e modem HSP-Modem V.90</td> </tr> <tr> <td>Gestione avanzata per il risparmio energetico. (requisiti ACPI 2.0 e APM 1.2)</td> </tr> </tbody> </table> <p>Altre caratteristiche fondamentali sono: supporto per otto porte USB, controller Fast Ethernet MAC, interfaccia AC' 97, Gestione avanzata per il risparmio energetico, controller DMA controller integrato e controller tastiera.</p>	Chipset	Caratteristiche	SiS741GX NB	Vengono supportate le CPU AMD Athlon XP/Sempron/Athlon / Duron con FSB fino a 333MHz	Supporta DDR 333/266 SDRAM	Compliant with Universal AGP 3.0 (supporta solo l'interfaccia 1.5V AGP)	Supporta l'interfaccia AGP 8X/4X con Funzione Transizione Fast Write	Motore 3D integrato di altissima qualità	Supporto per la gestione "Risparmio Energia" PCI garantendo la compatibilità con i controller ACPI	SiS964L SB	Conforme allo standard PCI 2.3	Supporto home networking full duplex per 10base-T, 100base-Tx, 1Mb/s & 10 Mb/s	Conforme allo standard AC' 97 v2.3 garantendo il supporto a 6 Canali delle uscite speaker AC' 97 e modem HSP-Modem V.90	Gestione avanzata per il risparmio energetico. (requisiti ACPI 2.0 e APM 1.2)
Chipset	Caratteristiche														
SiS741GX NB	Vengono supportate le CPU AMD Athlon XP/Sempron/Athlon / Duron con FSB fino a 333MHz														
	Supporta DDR 333/266 SDRAM														
	Compliant with Universal AGP 3.0 (supporta solo l'interfaccia 1.5V AGP)														
	Supporta l'interfaccia AGP 8X/4X con Funzione Transizione Fast Write														
	Motore 3D integrato di altissima qualità														
	Supporto per la gestione "Risparmio Energia" PCI garantendo la compatibilità con i controller ACPI														
SiS964L SB	Conforme allo standard PCI 2.3														
	Supporto home networking full duplex per 10base-T, 100base-Tx, 1Mb/s & 10 Mb/s														
	Conforme allo standard AC' 97 v2.3 garantendo il supporto a 6 Canali delle uscite speaker AC' 97 e modem HSP-Modem V.90														
	Gestione avanzata per il risparmio energetico. (requisiti ACPI 2.0 e APM 1.2)														
Memoria	<ul style="list-style-type: none"> • Presenta due slot a 184 pin 2.5 V unbuffered • Supporta un modulo di memoria SDRAM con DDR fino a 333/266 Mhz • Ciascun slot supporta fino a 1 GB per una capacità totale massima di 2 GB 														
Grafica	La scheda madre include uno slot AGP che fornisce otto volte la larghezza di banda delle specifiche AGP originarie. Lo standard AGP 3.0 (8XAGP) garantisce prestazioni significativamente superiori oltre ad altri miglioramenti rispetto allo standard AGP2.0. Questa interfaccia rappresenta la naturale evoluzione dell'AGP esistente ed è in grado di soddisfare le sempre maggiori aspettative del mercato nel campo delle interfacce grafiche, sia in ambiente workstation che in ambiente desktop.														
Audio	Il codec Audio AC'97 è conforme alla specifica AC' 97 2.3 che soddisfa i requisiti PC2001 e supporta Uscita S/PDFI. Inoltre ha una memoria tampone interna e PLL interno. Le														

	<p>caratteristiche includono supporto per interruttore analogico sull'uscita posteriore (condivisa), il jack di ingresso linea (condiviso), centrale/bassi (condivisi), e jack MIC per fornire un'uscita a 6 canali audio.</p>
Opzioni di espansione	<p>La scheda madre presenta le seguenti opzioni di espansione:</p> <ul style="list-style-type: none"> • Tre slot PCI 32 bit • Uno slot compatibile con lo standard AGP 3.0 8X/4X (supporta solo l'interfaccia 1.5V AGP) • Una slot Communications e Network Riser (CNR) (solo interfaccia AC' 97) • Due connettori IDE che supportano quattro grado IDE • Un'interfaccia per la gestione dei drive in grado di supportare 2 FDD <p>La scheda madre supporta il bus mastering Ultra DMA con transfer rate 33/66/100/133 MB/sec.</p>
LAN integrato (opzionale)	<p>La scheda LAN integrato é una periferica Fast Ethernet dotata di interfaccia MII per chip MAC. É dotata delle seguenti caratteristiche:</p> <ul style="list-style-type: none"> • Dotata di interfaccia MII • Supporto – 100/10 Mbps • Supporto Half e Full Duplex • Funzionamento a 3.3V con segnale a 5V • Basso consumo energetico
Inizializza I/O	<p>La scheda madre è dotata da una serie completa di porte e connettori I/O:</p> <ul style="list-style-type: none"> • Due porte PS/2 per tastiera e mouse • Una porta seriale (COM1) • Una porta VGA • Una porta parallela • Quattro porte USB • Una porta LAN (opzionale) • Jack audio per microfono, ingresso linea e uscita linea
Firmware BIOS	<p>Questa scheda madre adotta un BIOS Award che permette agli utenti di configurare le caratteristiche principali del sistema, inclusi:</p> <ul style="list-style-type: none"> • Gestione energia • Allarmi wake up • Parametri CPU • Temporizzazione CPU e memoria <p>Il firmware può anche essere usato per impostare i parametri per diverse velocità di clock.</p>



Alcune specifiche hardware ed elementi software sono soggetti a variazioni senza preavviso.

Características

Procesador	La placa principal usa un AMD 462-pin Receptáculo A que soporta el Bus de Lado Frontal (Front Side Bus/FSB) de 333/266/200 MHz, soporta una CPU AMD Athlon XP/Sempron /Athlon/Duron con FSB hasta 333 MHz.														
Chipset	<p>El chipset en esta placa principal incluye la SiS741GX Northbridge combinado con el chipset SiS964L Southbridge. La tabla abajo explica algunas de las características avanzadas del chipset:</p> <table border="1"> <thead> <tr> <th>Chipset</th> <th>Características</th> </tr> </thead> <tbody> <tr> <td rowspan="6">SiS741GX NB</td> <td>Soporta las CPUs AMD Athlon XP/Sempron/ Athlon / Duron con FSB hasta 333MHz</td> </tr> <tr> <td>Soporta DDR 333/266 SDRAM</td> </tr> <tr> <td>Conforme con Universal AGP 3.0 (soporta interfaz 1.5V AGP solamente)</td> </tr> <tr> <td>Soporta la interfaz AGP 8X/4X c/ Transacción de Escritura Rápida</td> </tr> <tr> <td>Procesador 3D de alta calidad incorporado</td> </tr> <tr> <td>Soporta los registros de configuración de administración de suministro PCI para soportar el controlador de apagado ACPI</td> </tr> <tr> <td rowspan="4">SiS964L SB</td> <td>Conforme con la especificación PCI 2.3.</td> </tr> <tr> <td>Soporta la red de trabajo residencial de duplex completo 10base-T, 100base-Tx, 1Mb/s & 10 Mb/s.</td> </tr> <tr> <td>Conforme con AC' 97 v2.3 que soporta 6 Canales de salidas de altoparlante AC' 97 y V.90 HSP-Módem</td> </tr> <tr> <td>Administración de Suministro Avanzada. (Requisitos de ACPI 2.0 y de APM 1.2)</td> </tr> </tbody> </table> <p>Características claves adicionales incluyen soporte para ocho puertos USB, controlador Fast Ethernet MAC, Interfaz AC' 97, Administración de Suministro Avanzada, controlador DMA integrado y controlador de teclado.</p>	Chipset	Características	SiS741GX NB	Soporta las CPUs AMD Athlon XP/Sempron/ Athlon / Duron con FSB hasta 333MHz	Soporta DDR 333/266 SDRAM	Conforme con Universal AGP 3.0 (soporta interfaz 1.5V AGP solamente)	Soporta la interfaz AGP 8X/4X c/ Transacción de Escritura Rápida	Procesador 3D de alta calidad incorporado	Soporta los registros de configuración de administración de suministro PCI para soportar el controlador de apagado ACPI	SiS964L SB	Conforme con la especificación PCI 2.3.	Soporta la red de trabajo residencial de duplex completo 10base-T, 100base-Tx, 1Mb/s & 10 Mb/s.	Conforme con AC' 97 v2.3 que soporta 6 Canales de salidas de altoparlante AC' 97 y V.90 HSP-Módem	Administración de Suministro Avanzada. (Requisitos de ACPI 2.0 y de APM 1.2)
Chipset	Características														
SiS741GX NB	Soporta las CPUs AMD Athlon XP/Sempron/ Athlon / Duron con FSB hasta 333MHz														
	Soporta DDR 333/266 SDRAM														
	Conforme con Universal AGP 3.0 (soporta interfaz 1.5V AGP solamente)														
	Soporta la interfaz AGP 8X/4X c/ Transacción de Escritura Rápida														
	Procesador 3D de alta calidad incorporado														
	Soporta los registros de configuración de administración de suministro PCI para soportar el controlador de apagado ACPI														
SiS964L SB	Conforme con la especificación PCI 2.3.														
	Soporta la red de trabajo residencial de duplex completo 10base-T, 100base-Tx, 1Mb/s & 10 Mb/s.														
	Conforme con AC' 97 v2.3 que soporta 6 Canales de salidas de altoparlante AC' 97 y V.90 HSP-Módem														
	Administración de Suministro Avanzada. (Requisitos de ACPI 2.0 y de APM 1.2)														
Memoria	<ul style="list-style-type: none"> • Acomoda dos ranuras 2.5V 184-pin sin buffer • Soporta DDR hasta módulo de memoria 333/266 MHz SDRAM • Cada ranura soporta hasta 1 GB con una capacidad máxima total de 2 GB 														
Gráficas	Esta placa principal incluye una ranura AGP que provee ocho veces la ancha de banda de la especificación de AGP original. El AGP 3.0 (8XAGP) ofrece un aumento significativo en rendimiento junto con mejoramientos de característica para AGP2.0. Esta interfaz representa la evolución natural del AGP existente para satisfacer las crecientes demandas enfocadas en las interfaces de gráficas dentro de los ambientes de estación de trabajo y sobremesas.														
Audio	El codec de sonido AC' 97 es conforme con la especificación AC' 97 2.3, que satisface los requisitos de PC2001 y soporta S/PDIF Out. También tiene un buffer incorporado y PLL.														

	<p>interno. Las características incluyen soporte para el interruptor analógico para salida trasera (compartir), la clavija de entrada de línea (compartir), centro/bajo (compartir), y clavija MIC para exportar sonido de 6 canales.</p>
Opciones de Expansión	<p>La placa principal viene con las sigtes. opciones de expansión:</p> <ul style="list-style-type: none"> • Tres ranuras 32-bit PCI • Una ranura con conformidad de AGP 3.0 con las velocidades 8X/4X (soporta interfaz 1.5V AGP solamente) • Una ranura de Communications Network Riser (CNR) (Interfaz AC: 97 solamente) • Dos conectores IDE que soportan cuatro dispositivos IDE • Una interfaz de unidad de disco floppy que soporta 2 dispositivos FDD <p>Esta placa principal soporta mastering de bus Ultra DMA con índices de transferencia de 33/66/100/133 MB/seg.</p>
LAN Abordo (optativo)	<p>El LAN Abordo es un Fast Ethernet Phyceiver con interfaz MII para el chip MAC. Provee las sigtes. características:</p> <ul style="list-style-type: none"> • Soporta Interfaz MII • Soporta operación 10/100Mbps • Soporta operación medio/full duplex • Operación 3.3V con señal 5V • Bajo consumo de operación
I/O Integrado	<p>La placa principal tiene un juego completo de puertos y conectores I/O:</p> <ul style="list-style-type: none"> • Dos puertos PS/2 para ratón y teclado • Un puerto serial (COM1) • Un puerto VGA • Un puerto paralelo • Cuatro puertos USB • Un puerto LAN (optativo) • Clavijas de sonido para micrófono, entrada y salida de línea
Firmware de BIOS	<p>Esta placa principal usa Awardl BIOS que habilita los usuarios a configurar muchas características de sistema que incluyen las sigtes.:</p> <ul style="list-style-type: none"> • Administración de energía • Alarmas despertadoras • Parámetros de CPU • Sincronización de CPU y de Memoria <p>El firmware también se puede usar para configurar parámetros para diferentes velocidades de reloj.</p>



Algunas especificaciones de hardware e ítems de software son sujetos a cambio sin previo aviso.

製品特徴

<p>プロセッサ</p>	<p>このマザーボードは333/266/200 MHzのフロントサイドバス(FSB)対応のAMD 462ピンSocket A仕様ソケットを搭載しておりますので、最大333 MHzのFSBでAMD Athlon XP/Sempron/Athlon/Duron CPU に対応します</p>														
<p>チップセット</p>	<p>当マザーボードに搭載されているチップセットは、SiS741GX Northbridge と、SiS964Lかの Southbridgeとで構成されたもので、下表に示される先進な機能をお届けします。</p> <table border="1" data-bbox="600 689 1204 1350"> <thead> <tr> <th data-bbox="600 689 742 757">チップセット名</th> <th data-bbox="750 689 1204 757">機能</th> </tr> </thead> <tbody> <tr> <td data-bbox="600 763 742 1070" rowspan="6"> <p>SiS741GX NB</p> </td> <td data-bbox="750 763 1204 819"> <p>最大333 MHz のFSBでAMD Athlon XP/Sempron /Athlon/Duron CPU に対応</p> </td> </tr> <tr> <td data-bbox="750 826 1204 860"> <p>DDR 333/266 SDRAMをサポート</p> </td> </tr> <tr> <td data-bbox="750 866 1204 922"> <p>AGP 3.0に対応(1.5V AGPインターフェースのみ対応)</p> </td> </tr> <tr> <td data-bbox="750 929 1204 985"> <p>高速書込み方式の AGP 8X/4X インターフェースをもサポート</p> </td> </tr> <tr> <td data-bbox="750 992 1204 1025"> <p>高品質3Dエンジン内蔵</p> </td> </tr> <tr> <td data-bbox="750 1032 1204 1088"> <p>PCI電源管理設定登録機能でACPIパワーダウンコントロールをサポート</p> </td> </tr> <tr> <td data-bbox="600 1095 742 1350" rowspan="4"> <p>SiS964L SB</p> </td> <td data-bbox="750 1095 1204 1128"> <p>PCI 2.3 仕様に準拠</p> </td> </tr> <tr> <td data-bbox="750 1135 1204 1225"> <p>全二重の10base-Tと100base-Txとの他に、1Mb/秒 & 10 Mb/秒のホームネットワーク機能をもサポート</p> </td> </tr> <tr> <td data-bbox="750 1232 1204 1299"> <p>AC' 97 v2.3 に準拠することで6 チャンネル AC' 97 スピーカ出力と V.90 HSP-モデムをサポート</p> </td> </tr> <tr> <td data-bbox="750 1305 1204 1350"> <p>APMによる電源管理可能。(ACPI 2.0 仕様と APM 1.2 仕様に準拠。)</p> </td> </tr> </tbody> </table> <p>この他に、8つのUSBポート、高速イーサネットMACコントローラ、AC' 97インターフェース、アドバンス電源管理機能、統合DMAコントローラ、キーボードコントローラなどの機能を搭載しています。</p>	チップセット名	機能	<p>SiS741GX NB</p>	<p>最大333 MHz のFSBでAMD Athlon XP/Sempron /Athlon/Duron CPU に対応</p>	<p>DDR 333/266 SDRAMをサポート</p>	<p>AGP 3.0に対応(1.5V AGPインターフェースのみ対応)</p>	<p>高速書込み方式の AGP 8X/4X インターフェースをもサポート</p>	<p>高品質3Dエンジン内蔵</p>	<p>PCI電源管理設定登録機能でACPIパワーダウンコントロールをサポート</p>	<p>SiS964L SB</p>	<p>PCI 2.3 仕様に準拠</p>	<p>全二重の10base-Tと100base-Txとの他に、1Mb/秒 & 10 Mb/秒のホームネットワーク機能をもサポート</p>	<p>AC' 97 v2.3 に準拠することで6 チャンネル AC' 97 スピーカ出力と V.90 HSP-モデムをサポート</p>	<p>APMによる電源管理可能。(ACPI 2.0 仕様と APM 1.2 仕様に準拠。)</p>
チップセット名	機能														
<p>SiS741GX NB</p>	<p>最大333 MHz のFSBでAMD Athlon XP/Sempron /Athlon/Duron CPU に対応</p>														
	<p>DDR 333/266 SDRAMをサポート</p>														
	<p>AGP 3.0に対応(1.5V AGPインターフェースのみ対応)</p>														
	<p>高速書込み方式の AGP 8X/4X インターフェースをもサポート</p>														
	<p>高品質3Dエンジン内蔵</p>														
	<p>PCI電源管理設定登録機能でACPIパワーダウンコントロールをサポート</p>														
<p>SiS964L SB</p>	<p>PCI 2.3 仕様に準拠</p>														
	<p>全二重の10base-Tと100base-Txとの他に、1Mb/秒 & 10 Mb/秒のホームネットワーク機能をもサポート</p>														
	<p>AC' 97 v2.3 に準拠することで6 チャンネル AC' 97 スピーカ出力と V.90 HSP-モデムをサポート</p>														
	<p>APMによる電源管理可能。(ACPI 2.0 仕様と APM 1.2 仕様に準拠。)</p>														
<p>グラフィック</p>	<ul style="list-style-type: none"> • 2つの非バッファ2.5V184ピン仕様のスロットを備え • DDR 333/266 MHz SDRAMまでのDDRメモリモジュールに対応 • 各スロットが1 GBまで対応し、合計で2 GBまでのメモリをサポート 														
<p>オーディオ</p>	<p>このマザーボードは、本来のAGP仕様の8倍の帯域幅を提供することができるAGPスロットが含まれています。AGP 3.0 (8XAGP)はAGP2.0をより向上させた極めて高い性能を提供しています。このインターフェースは、既存のAGPから無理なく自然な革新をはかり、ワークステーションやデスクトップ環境におけるグラフィックインターフェースに対するニーズを強化しています。</p>														

オーディオ	AC' 97 オーディオコーデックはAC' 97 2.3 仕様に適合したもので、PC2001要求を満たし、S/PDIF Outに対応しています。また、内蔵バッファと内部PLLを搭載しています。このほかに、背面用アナログスイッチ(共有)、ライン入力ジャック(共有)、中央/ベース (共有)、6チャンネル出力オーディオ用MICジャックなどを備えています。
拡張オプション	このメインボードには次の拡張オプションがあります： <ul style="list-style-type: none"> ● 3つの32ビットPCIスロット ● 1つのAGPスロット (1.5V AGPインターフェースのみ対応) ● 通信ネットワークライザ (CNR) スロット (AC' 97インターフェースのみ) ● 2つのIDE コネクタ、それで4つまでの IDE 装置を接続可能 ● 1つのフロッピーディスクインターフェース、それで2つまでのFDDデバイスを接続可能。 さらに、33/66/100/133 MB/秒の転送レートでUltra DMAバスマスタリングに対応しています。
オンボードLAN (オプション)	<ul style="list-style-type: none"> ● オンボードLANチップは Fast Ethernet Phyceiver であって、MACチップと接続するMII インターフェースを取り入れ、かつ次の特徴があります ● MIIインターフェースをサポート ● 10/100Mbps動作をサポート ● 半/全二重動作をサポート ● 5V仕様信号での3.3V動作 ● 低消費電力
統合の入出力ポート	このメインボードはフルセットのI/Oポートおよびコネクタを搭載しています。 <ul style="list-style-type: none"> ● 2つのPS/2ポート (マウス用とキーボード用) ● 1つのシリアルポート (COM1) ● 1つのVGA ポート ● 1つのパラレルポート ● 4つのUSBポート ● 1つのLANポート (オプション) ● マイクロフォンやラインイン、ラインアウト向けのオーディオジャック
BIOS ファームウェア	このメインボードは次のシステム機能を含めた設定をすることができるAward BIOSを採用しています： <ul style="list-style-type: none"> ● 電源管理 ● Wake-up警告 ● CPUパラメータ ● CPUおよびメモリのタイミング この他に、各種プロセッサクロック速度のパラメータを設定することができます。



一部のハードウェア仕様及びソフトウェアアイテムは予告なく変更されることがあります。

기능

프로세서	마더보드는 333/266/200 MHz Front Side Bus (FSB) 를 지원하는 AMD 462 핀 소켓 A 를 사용하여, AMD 애슬론 XP/샘프론/애슬론/듀론 CPU 에 FSB를 최대 333 MHz 까지 지원한다.														
칩셋	<p>본 마더보드에 있는 칩셋은 SiS741GX Northbridge 와 SiS964L Southbridge 칩셋을 조합한다. 아래 표는 칩셋의 고급 기능을 간단히 설명한다.</p> <table border="1"> <thead> <tr> <th>칩셋</th> <th>특징</th> </tr> </thead> <tbody> <tr> <td rowspan="6">SiS741GX NB</td> <td>최대 FSB 333MHz 의 AMD 애슬론 XP/샘프론/애슬론/듀론 CPU 지원</td> </tr> <tr> <td>DDR 333/266 SDRAM 지원</td> </tr> <tr> <td>Universal AGP 3.0 호환 (1.5V AGP 인터페이스만 지원)</td> </tr> <tr> <td>AGP 8X/4X 인터페이스 w/ Fast Write Transaction 지원</td> </tr> <tr> <td>고 품질의 3D 엔진 내장</td> </tr> <tr> <td>ACPI 파워 다운 컨트롤러 지원을 위한 PCI 전원 관리 구성 레지스터 지원</td> </tr> <tr> <td rowspan="4">SiS964L SB</td> <td>PCI 2.3 사양 준수</td> </tr> <tr> <td>전이중 10base-T, 100base-Tx, 1Mb/s 및 10Mb/s 홈 네트워킹 지원</td> </tr> <tr> <td>6개 채널의 AC' 97 스피커 출력 및 V.90 HSP-모뎀을 지원하는 AC' 97 v2.3 호환</td> </tr> <tr> <td>고급 전원 관리 (ACPI 2.0 요구 사항 및 APM 1.2 요구 사항)</td> </tr> </tbody> </table> <p>그 밖의 주요 특징으로 8 개의 USB 포트, 패스트 이더넷 MAC 컨트롤러, AC' 97 인터페이스, 고급 전원 관리, 통합 DMA 컨트롤러 및 키보드 컨트롤러를 지원한다.</p>	칩셋	특징	SiS741GX NB	최대 FSB 333MHz 의 AMD 애슬론 XP/샘프론/애슬론/듀론 CPU 지원	DDR 333/266 SDRAM 지원	Universal AGP 3.0 호환 (1.5V AGP 인터페이스만 지원)	AGP 8X/4X 인터페이스 w/ Fast Write Transaction 지원	고 품질의 3D 엔진 내장	ACPI 파워 다운 컨트롤러 지원을 위한 PCI 전원 관리 구성 레지스터 지원	SiS964L SB	PCI 2.3 사양 준수	전이중 10base-T, 100base-Tx, 1Mb/s 및 10Mb/s 홈 네트워킹 지원	6개 채널의 AC' 97 스피커 출력 및 V.90 HSP-모뎀을 지원하는 AC' 97 v2.3 호환	고급 전원 관리 (ACPI 2.0 요구 사항 및 APM 1.2 요구 사항)
칩셋	특징														
SiS741GX NB	최대 FSB 333MHz 의 AMD 애슬론 XP/샘프론/애슬론/듀론 CPU 지원														
	DDR 333/266 SDRAM 지원														
	Universal AGP 3.0 호환 (1.5V AGP 인터페이스만 지원)														
	AGP 8X/4X 인터페이스 w/ Fast Write Transaction 지원														
	고 품질의 3D 엔진 내장														
	ACPI 파워 다운 컨트롤러 지원을 위한 PCI 전원 관리 구성 레지스터 지원														
SiS964L SB	PCI 2.3 사양 준수														
	전이중 10base-T, 100base-Tx, 1Mb/s 및 10Mb/s 홈 네트워킹 지원														
	6개 채널의 AC' 97 스피커 출력 및 V.90 HSP-모뎀을 지원하는 AC' 97 v2.3 호환														
	고급 전원 관리 (ACPI 2.0 요구 사항 및 APM 1.2 요구 사항)														
메모리	<ul style="list-style-type: none"> • 2 개의 unbuffered 2.5V 184 핀 슬롯 사용 • DDR을 최대 333/266 MHz SDRAM 메모리 모듈 지원 • 각 슬롯은 최대 1 GB 지원. 총 최대 용량은 2 GB 														
그래픽	본 마더보드는 기존 AGP 사양보다 8배의 대역폭을 제공하는 AGP 슬롯이 포함되어 있다. AGP 3.0 (8XAGP) 은 AGP 2.0의 기능을 보강한 월등한 성능을 제공한다. 이 인터페이스는 기존 AGP의 자연적 진화로 워크스테이션과 데스크 탑 환경에서 대폭 증가된 그래픽 인터페이스의 요구 조건을 만족시킨다.														
오디오	AC' 97 오디오 코덱은 AC' 97 2.2 사양과 호환하여 PC2001 요구 사항에 부합하며 S/PDIF Out을 지원한다. 버퍼 및 PLL이 내장되어 있으며, 후면-출력 (공유), 라인 입력 잭 (공유), 중앙/베이스 (공유), 및 6 채널 오디오 출력 용 MIC 잭을 위한 아날로그 스위치를 포함한다.														
확장 옵션	<p>본 마더보드는 다음과 같은 확장 옵션이 있다:</p> <ul style="list-style-type: none"> • 32 비트 PCI 슬롯 3 개 														

	<ul style="list-style-type: none"> • 8X/4X 배속 AGP 3.0 호환 슬롯 1 개 (1.5V AGP 인터페이스만 지원) • Communications Network Riser (CNR) 슬롯 1 개 (AC' 97 인터페이스에만 해당) • 4 개의 드라이브 인터페이스를 지원하는 2 개의 IDE 커넥터 • 2 개의 FDD 장치를 지원할 수 있는 플로피 디스크 드라이브 인터페이스 1 개 <p>본 마더보드는 전송 속도 33/66/100/133 MB/sec 의 Ultra DMA bus mastering 을 지원한다.</p>
보드 내장 LAN (선택 사항)	<p>보드 내장 LAN은 MAC 칩에 MII 인터페이스를 지닌 패스트 이더넷 Phyceiver 이며 다음과 같은 특징을 지닌다:</p> <ul style="list-style-type: none"> • MII 인터페이스 지원 • 10/100Mbps 오퍼레이션 지원 • half/full 이중 오퍼레이션 지원 • 5V 시그널과 함께 3.3V 오퍼레이션 • 낮은 전력 소모
통합 I/O	<p>이 메인보드에는 풀 세트의 I/O 포트와 커넥터가 있다:</p> <ul style="list-style-type: none"> • 마우스와 키보드용 PS/2 포트 2 개 • 시리얼 포트 1개 (COM1) • VGA 포트 1개 • 패러럴 포트 1 개 • USB 포트 4개 • LAN 포트 1 개 (선택 사항) • 마이크용 오디오 잭, 라인 입력과 라인 출력
BIOS 펌웨어	<p>이 메인 보드는 Award BIOS 를 사용하여 사용자는 다음과 같은 시스템 기능을 구성할 수 있다:</p> <ul style="list-style-type: none"> • 전원 관리 • 기상 알람 • CPU 파라미터 • CPU 및 메모리 타이밍 <p>펌웨어는 다른 프로세서의 클럭 속도 설정에도 사용할 수 있다.</p>



하드웨어 사양 및 소프트웨어 아이템은 사전 통보 없이 변경될 수 있음.

性能

處理器	本主機板配備有一個支援 333/266/200 MHz 前端匯流排的AMD 462針Socket A式插座，藉此能以高達333MHz之FSB支援AMD Athlon XP/Sempron/Athlon/Duron CPU。															
晶片組	<p>本主機板係以SiS741GX北橋晶片組搭配SiS964L南橋晶片組，具有如下表所述之先進功能：</p> <table border="1"> <thead> <tr> <th>晶片組</th> <th>功能</th> </tr> </thead> <tbody> <tr> <td rowspan="5">SiS741GX NB</td> <td>支援 AMD Athlon XP/Sempron/ Athlon/ Duron CPU，FSB可高達333MHz。</td> </tr> <tr> <td>支援DDR 333/266 SDRAM</td> </tr> <tr> <td>相容於AGP 3.0規格(僅支援1.5伏特電壓規格)</td> </tr> <tr> <td>支援AGP 8X/4X 介面，具有快寫處理功能</td> </tr> <tr> <td>內建高品質3D引擎</td> </tr> <tr> <td></td> <td>支援PCI電源管理設定登錄，可支援ACPI斷電控制器</td> </tr> <tr> <td rowspan="4">SiS964L SB</td> <td>相容於 PCI 2.3 規格</td> </tr> <tr> <td>支援全雙工 10base-T及100base-Tx，同時也支援1Mb/秒 & 10 Mb/秒的家庭無線網路(home networking)</td> </tr> <tr> <td>相容於AC' 97 v2.3，可支援 6聲頻的AC' 97 喇叭輸出以及V.90 HSP-數據器</td> </tr> <tr> <td>具備先進電源管理功能。(符合ACPI 2.0 及 APM 1.2 規格)</td> </tr> </tbody> </table> <p>另外主要功能包括支援8個USB埠,高速乙太MAC控制器存取控制層, AC' 97介面,內建DMA控制器和鍵盤控制器。</p>	晶片組	功能	SiS741GX NB	支援 AMD Athlon XP/Sempron/ Athlon/ Duron CPU，FSB可高達333MHz。	支援DDR 333/266 SDRAM	相容於AGP 3.0規格(僅支援1.5伏特電壓規格)	支援AGP 8X/4X 介面，具有快寫處理功能	內建高品質3D引擎		支援PCI電源管理設定登錄，可支援ACPI斷電控制器	SiS964L SB	相容於 PCI 2.3 規格	支援全雙工 10base-T及100base-Tx，同時也支援1Mb/秒 & 10 Mb/秒的家庭無線網路(home networking)	相容於AC' 97 v2.3，可支援 6聲頻的AC' 97 喇叭輸出以及V.90 HSP-數據器	具備先進電源管理功能。(符合ACPI 2.0 及 APM 1.2 規格)
晶片組	功能															
SiS741GX NB	支援 AMD Athlon XP/Sempron/ Athlon/ Duron CPU，FSB可高達333MHz。															
	支援DDR 333/266 SDRAM															
	相容於AGP 3.0規格(僅支援1.5伏特電壓規格)															
	支援AGP 8X/4X 介面，具有快寫處理功能															
	內建高品質3D引擎															
	支援PCI電源管理設定登錄，可支援ACPI斷電控制器															
SiS964L SB	相容於 PCI 2.3 規格															
	支援全雙工 10base-T及100base-Tx，同時也支援1Mb/秒 & 10 Mb/秒的家庭無線網路(home networking)															
	相容於AC' 97 v2.3，可支援 6聲頻的AC' 97 喇叭輸出以及V.90 HSP-數據器															
	具備先進電源管理功能。(符合ACPI 2.0 及 APM 1.2 規格)															
記憶體	<ul style="list-style-type: none"> • 搭配有2個無緩衝2.5v 184針之插槽 • 支援高達 DDR 333/266 MHz 之 SDRAM模組 • 各插槽支援1GB記憶體，共可支援高達2GB的記憶體 															
繪圖卡	本主機板 配備有一個AGP插槽，能夠支援為舊型AGP規格8倍之頻寬。此AGP 3.0 (8XAGP) 能夠顯著增強AGP2.0之性能以及增其特色。本介面係順應工作站與個人電腦環境中對圖形介面不斷升高之要求，由既有之AGP規格所發展出來的成果。															
音效	配備之AC' 97音效解碼/編碼器，係採用AC' 97 2.3規格，該規格符合PC2001規格要求並支援S/PDIF 輸出。同時，本解碼/編碼器也具有內建緩衝器和內裝PLL。在功能上，尚包括：支援後聲道輸出(共用)、外部音源輸入(共用)、center/bass(共用)、以及可輸出6聲道音效之麥克風接頭。															
擴充選項	<p>本主機板機載有下列擴充選項:</p> <ul style="list-style-type: none"> • 3個32位元PCI插槽 • 1個 AGP 3.0 相容插槽，支援8X/4X (僅支援1.5伏特電壓規格) • 1個通訊網路附加卡(Communications Network Riser, CNR) 插槽 (僅支援AC' 97介面) • 2個IDE連接頭，可連接4個IDE裝置 															

	<ul style="list-style-type: none"> • 1個軟碟機介面，可連接 2個 FDD裝置 <p>此外，也支援Ultra DMA 匯流排主控功能，可提供33/66/100/ 133 MB/sec之傳輸速率。</p>
機載LAN功能 (選購)	<p>機載 LAN 晶片為一個高速乙太網路 Phyceiver，具有連接至MAC晶片的 MII 介面。此外，尚具有如下特點：</p> <ul style="list-style-type: none"> • 支援 MII介面 • 支援 10/100Mbps 傳輸 • 支援半/全雙工運作 • 動作電壓3.3V，信號電壓5V • 耗電量低
整合的輸入出功能	<p>本主機板完整地支援各種輸入及連接器：</p> <ul style="list-style-type: none"> • 2個 PS/2 埠，分供滑鼠及鍵盤連接 • 1個串列埠(COM1) • 1個VGA埠 • 1個平行埠 • 4個USB埠 • 1個LAN埠(選購) • 麥克風、線級輸入及線級輸出音效端子
BIOS韌體	<p>本主機板使用了Award BIOS，使用者可藉此對包括下列之系統功能進行設定：</p> <ul style="list-style-type: none"> • 電源管理 • 喚醒警示 • CPU參數 • CPU及記憶體的時脈 <p>本BIOS也可用以設定各種有關處理器頻率的參數。</p>



有些硬體規格以及軟體物件將視狀況適當調整，不予另行通知。

特性

处理器	主板使用 AMD 462-pin Socket A 插座, 支持 333/266/200 MHz 前端总线 (FSB), 支持 FSB 达 333 MHz 的 AMD Athlon XP/Sempron/Athlon/Duron CPU。													
芯片组	<p>此主板使用了 SiS741GX 北桥和 SiS964L 南桥芯片组。下表中简要介绍了芯片组的先进功能。</p> <table border="1" data-bbox="600 607 1204 1128"> <thead> <tr> <th data-bbox="600 607 740 645">芯片组</th> <th data-bbox="748 607 1204 645">功能</th> </tr> </thead> <tbody> <tr> <td data-bbox="600 651 740 936" rowspan="5">SiS741GX NB</td> <td data-bbox="748 651 1204 712">支持最高 FSB 为 333MHz 的 AMD Athlon XP/Sempron/Athlon / Duron CPU</td> </tr> <tr> <td data-bbox="748 719 1204 745">支持 DDR 333/266 SDRAM</td> </tr> <tr> <td data-bbox="748 752 1204 813">符合通用 AGP 3.0 标准 (只支持 1.5V AGP 接口)</td> </tr> <tr> <td data-bbox="748 819 1204 846">支持带快写处理功能的 AGP 8X/4X 接口</td> </tr> <tr> <td data-bbox="748 853 1204 880">内建高质量 3D 引擎</td> </tr> <tr> <td data-bbox="600 943 740 1128" rowspan="4">SiS964L SB</td> <td data-bbox="748 943 1204 969">符合 PCI 2.3 规格</td> </tr> <tr> <td data-bbox="748 976 1204 1037">支持全双工 10base-T、100base-Tx、1Mb/s & 10 Mb/s 本地网络</td> </tr> <tr> <td data-bbox="748 1043 1204 1104">符合 AC' 97 v2.3 (支持 AC' 97 扬声器 6 通道) 标准和 V.90 HSP-Modem 标准</td> </tr> <tr> <td data-bbox="748 1111 1204 1128">高级电源管理 (需要 ACPI 2.0 和 APM 1.2)</td> </tr> </tbody> </table> <p>它主要功能包括支持 8 个 USB 端口、高速以太网 MAC 控制器、AC' 97 接口、高级电源管理、集成 DMA 控制器和键盘控制器。</p>	芯片组	功能	SiS741GX NB	支持最高 FSB 为 333MHz 的 AMD Athlon XP/Sempron/Athlon / Duron CPU	支持 DDR 333/266 SDRAM	符合通用 AGP 3.0 标准 (只支持 1.5V AGP 接口)	支持带快写处理功能的 AGP 8X/4X 接口	内建高质量 3D 引擎	SiS964L SB	符合 PCI 2.3 规格	支持全双工 10base-T、100base-Tx、1Mb/s & 10 Mb/s 本地网络	符合 AC' 97 v2.3 (支持 AC' 97 扬声器 6 通道) 标准和 V.90 HSP-Modem 标准	高级电源管理 (需要 ACPI 2.0 和 APM 1.2)
芯片组	功能													
SiS741GX NB	支持最高 FSB 为 333MHz 的 AMD Athlon XP/Sempron/Athlon / Duron CPU													
	支持 DDR 333/266 SDRAM													
	符合通用 AGP 3.0 标准 (只支持 1.5V AGP 接口)													
	支持带快写处理功能的 AGP 8X/4X 接口													
	内建高质量 3D 引擎													
SiS964L SB	符合 PCI 2.3 规格													
	支持全双工 10base-T、100base-Tx、1Mb/s & 10 Mb/s 本地网络													
	符合 AC' 97 v2.3 (支持 AC' 97 扬声器 6 通道) 标准和 V.90 HSP-Modem 标准													
	高级电源管理 (需要 ACPI 2.0 和 APM 1.2)													
内存	<ul style="list-style-type: none"> 提供 2 个非缓冲 2.5V 184 pin 插槽 支持 333/266 MHz DDR SDRAM 内存条 每个插槽支持 1 GB, 总共最大可支持 2 GB 													
图形	该主板包括一个 AGP 插槽, 可提供普通 AGP 规格 8 倍的带宽。AGP 3.0 (8xAGP) 在增强了 AGP2.0 功能的同时极大地提高了性能。此接口反映了 AGP 的发展规律, 它进一步满足了在工作站和桌面环境中对图形接口的不断增长的要求。													
音频	AC' 97 Audio 编解码器兼容 AC' 97 2.3 规格, 符合 PC2001 标准, 支持 S/PDIF Out。它还带有集成缓存和内部 PLL。它支持用于后置输出的模拟开关 (共享)、线入插孔 (共享)、中置/低音 (共享) 和输出 6 路音频的 MIC 插孔。													
扩展 选项	<p>此主板提供如下扩展选项</p> <ul style="list-style-type: none"> 3 个 32 位 PCI 扩展插槽 1 个 8X/4X 速度的 AGP 3.0 插槽 (只支持 1.5V AGP 接口) 1 个通信网络转接 (CNR) 插槽 (仅对于 AC' 97 接口) 2 个 IDE 接口, 可支持 4 个 IDE 驱设备 1 个软驱接口, 可支持 2 个软驱设备 <p>此主办支持 Ultra DMA 总线控制, 传输速率可达 33/66/100/</p>													

	133 MB/sec。
Onboard LAN (可选)	<p>Onboard LAN 是一个高速以太网 Phyceiver，带有到 MAC 芯片的 MII 接口。它具有以下特点：</p> <ul style="list-style-type: none"> • 支持 MII 接口 • 支持 10/100Mbps 工作 • 支持半双工/全双工工作 • 3.3V 工作，5V 信号 • 低功耗
集成 I/O	<p>此主板具有完整的 I/O 端口和插孔：</p> <ul style="list-style-type: none"> • 2 个用于连接鼠标和键盘的 PS/2 端口 • 1 个串口 (COM1) • 1 个 VGA 端口 • 1 个并口 • 4 个 USB 端口 • 1 个 LAN 端口 (可选) • 麦克风、线入和线出声音插孔
BIOS	<p>此主板使用 Award BIOS，可以让用户自己配置以下系统功能：</p> <ul style="list-style-type: none"> • 电源管理 • 唤醒报警 • CPU 参数 • CPU 和记忆定时 <p>还可用于设置不同处理器时钟速度的参数。</p>



部分硬件规格和软件项目若有更改恕不另行通知。

Chapter 1

Introducing the Motherboard

Introduction

Thank you for choosing 741GX-M motherboard. This motherboard is designed to fit the advanced AMD processors in the 462-pin package. This motherboard is based on micro-ATX form factor featuring the SiS741GX Northbridge and SiS964L Southbridge chipsets. It accommodates AMD Athlon XP / Sempron / Athlon / Duron Processors supporting Front Side Bus (FSB) up to 333 / 266 / 200 MHz. In addition, the motherboard has 2 built-in 184-pin DIMM slots, and the main memory is expandable to a maximum of 2GB.

The SiS741GX Northbridge chipset features an AGP 8X bridge and a DDR-333 Memory controller, supporting AMD Athlon XP / Sempron / Athlon / Duron processors with FSB up to 333MHz. While the SiS964L Southbridge chipset provides eight USB 2.0 ports, 6-channels audio speaker compliant with AC' 97 v2.3 specification, IDE channels PIO mode 0, 1, 2, 3, 4 and Ultra DMA 133/100/66/33.

This high performance motherboard is intended to give customers a high quality, multimedia solution and state-of-the-art technology. It provides a complete set of I/O ports, such as dual channel IDE interfaces, a floppy controller, a serial port, a VGA port, an EPP/ECP capable bi-directional parallel port connector, four USB (Universal Serial Bus) connectors, LAN port, a PS/2 keyboard and mouse connector, and audio jacks for microphone, line-in, line-out. One AGP slot (support 1.5V AGP interface only), three PCI local bus slots and one CNR (Communication and Networking Riser) slot providing expandability for add-on peripheral cards.

Features

Processor	The motherboard uses an AMD 462-pin Socket A that supports 333/266/200 MHz Front Side Bus (FSB), supporting AMD Athlon XP/Sempron/Athlon/Duron CPU with FSB up to 333 MHz.														
Chipset	<p>The chipset on this motherboard includes the SiS741GX Northbridge combine with SiS964L Southbridge chipset. The table below briefly explains some of the chipset's advanced features.</p> <table border="1" data-bbox="600 674 1204 1240"> <thead> <tr> <th data-bbox="600 674 740 707">Chipset</th> <th data-bbox="748 674 1204 707">Features</th> </tr> </thead> <tbody> <tr> <td data-bbox="600 714 740 1016" rowspan="6">SiS741GX NB</td> <td data-bbox="748 714 1204 770">Supports AMD Athlon XP/Sempron/Athlon/Duron CPU with FSB up to 333 MHz</td> </tr> <tr> <td data-bbox="748 777 1204 799">Supports DDR 333/266 DDR SDRAM</td> </tr> <tr> <td data-bbox="748 806 1204 862">Compliant with Universal AGP 3.0 (support 1.5V AGP interface only)</td> </tr> <tr> <td data-bbox="748 869 1204 913">Supports AGP 8X/4X Interface w/ Fast Write Transaction</td> </tr> <tr> <td data-bbox="748 920 1204 943">Built-in a high quality 3D engine</td> </tr> <tr> <td data-bbox="748 949 1204 1016">Supports PCI power management configuration registers for supporting ACPI power down controller</td> </tr> <tr> <td data-bbox="600 1023 740 1240" rowspan="4">SiS964L SB</td> <td data-bbox="748 1023 1204 1046">Compliant with PCI 2.3 specification</td> </tr> <tr> <td data-bbox="748 1052 1204 1108">Supports full duplex 10base-T, 100base-Tx, 1 Mb/s & 10 Mb/s Home Networking</td> </tr> <tr> <td data-bbox="748 1115 1204 1182">Compliant with AC' 97 v2.3 supporting 6 Channels of AC' 97 speaker outputs and V.90 HSP-Modem</td> </tr> <tr> <td data-bbox="748 1189 1204 1240">Advanced Power Management (ACPI 2.0 requirements and APM 1.2 requirements)</td> </tr> </tbody> </table> <p data-bbox="600 1272 1204 1375">Additional key features include support for eight USB ports, Fast Ethernet MAC controller, AC' 97 interface, advanced power management, integrated DMA controller and keyboard controller.</p>	Chipset	Features	SiS741GX NB	Supports AMD Athlon XP/Sempron/Athlon/Duron CPU with FSB up to 333 MHz	Supports DDR 333/266 DDR SDRAM	Compliant with Universal AGP 3.0 (support 1.5V AGP interface only)	Supports AGP 8X/4X Interface w/ Fast Write Transaction	Built-in a high quality 3D engine	Supports PCI power management configuration registers for supporting ACPI power down controller	SiS964L SB	Compliant with PCI 2.3 specification	Supports full duplex 10base-T, 100base-Tx, 1 Mb/s & 10 Mb/s Home Networking	Compliant with AC' 97 v2.3 supporting 6 Channels of AC' 97 speaker outputs and V.90 HSP-Modem	Advanced Power Management (ACPI 2.0 requirements and APM 1.2 requirements)
Chipset	Features														
SiS741GX NB	Supports AMD Athlon XP/Sempron/Athlon/Duron CPU with FSB up to 333 MHz														
	Supports DDR 333/266 DDR SDRAM														
	Compliant with Universal AGP 3.0 (support 1.5V AGP interface only)														
	Supports AGP 8X/4X Interface w/ Fast Write Transaction														
	Built-in a high quality 3D engine														
	Supports PCI power management configuration registers for supporting ACPI power down controller														
SiS964L SB	Compliant with PCI 2.3 specification														
	Supports full duplex 10base-T, 100base-Tx, 1 Mb/s & 10 Mb/s Home Networking														
	Compliant with AC' 97 v2.3 supporting 6 Channels of AC' 97 speaker outputs and V.90 HSP-Modem														
	Advanced Power Management (ACPI 2.0 requirements and APM 1.2 requirements)														
Memory	<ul style="list-style-type: none"> • Accommodates two unbuffered 2.5V 184-pin slots • Supports DDR up to 333/266 MHz SDRAM memory module • Each slot supports up to 1 GB with a total maximum capacity of 2 GB 														
Graphics	This motherboard includes an AGP slot that provides eight times the bandwidth of the original AGP specification. The AGP 3.0 (8X AGP) offers a significant increase in performance along with feature enhancements to AGP2.0. This interface represents the natural evolution from the existing AGP to meet the ever-increasing demands placed on the graphic interfaces within the workstation and desktop environments.														

Audio	The AC' 97 Audio codec is compliant with the AC' 97 2.3 specification that meets the PC2001 requirements and supports S/PDIF Out. It also has a built-in buffer and internal PLL. Features include support for analog switch for rear-out (share), the line-in jack (share), center/bass (share), and MIC jack to output 6 channels audio.
Expansion Options	The motherboard comes with the following expansion options: <ul style="list-style-type: none"> • Three 32-bit PCI slots • One AGP 3.0 compliant slot with 8X/4X speed (supports 1.5V AGP Interface only) • A Communications Network Riser (CNR) slot (AC' 97 interface only) • Two IDE connectors which support four IDE devices • One floppy disk drive interface which can support 2 FDD devices This motherboard supports Ultra DMA bus mastering with transfer rates of 33/66/100/133 MB/sec.
Onboard LAN (optional)	The onboard LAN is a Fast Ethernet Phyceiver with MII interface to MAC chip. It provides the following features: <ul style="list-style-type: none"> • Support MII interface • Support 10/100Mbps operation • Support half/full duplex operation • 3.3V operation with 5V signal • Low operation power consumption
Integrated I/O	The motherboard has a full set of I/O ports and connectors: <ul style="list-style-type: none"> • Two PS/2 ports for mouse and keyboard • One serial port (COM1) • One VGA port • One parallel port • Four USB ports • One LAN port (optional) • Audio jacks for microphone, line-in and line-out
BIOS Firmware	This motherboard uses Award BIOS that enables users to configure many system features including the following: <ul style="list-style-type: none"> • Power management • Wake-up alarms • CPU parameters • CPU and memory timing The firmware can also be used to set parameters for different processor clock speeds.



Some hardware specifications and software items are subject to change without prior notice.

Choosing a Computer Case

There are many types of computer cases on the market. The motherboard complies with the specifications for the micro-ATX system case. Some features on the motherboard are implemented by cabling connectors on the motherboard to indicators and switches on the system case. Ensure that your case supports all the features required. The motherboard can support one or two floppy diskette drives and four enhanced IDE drives. Ensure that your case has sufficient power and space for all the drives that you intend to install.

Most cases have a choice of I/O templates in the rear panel. Make sure that the I/O template in the case matches the I/O ports installed on the rear edge of the motherboard.

This motherboard has a micro-ATX form factor of 244 x 244 mm. Choose a case that accommodates this form factor.

Motherboard Components

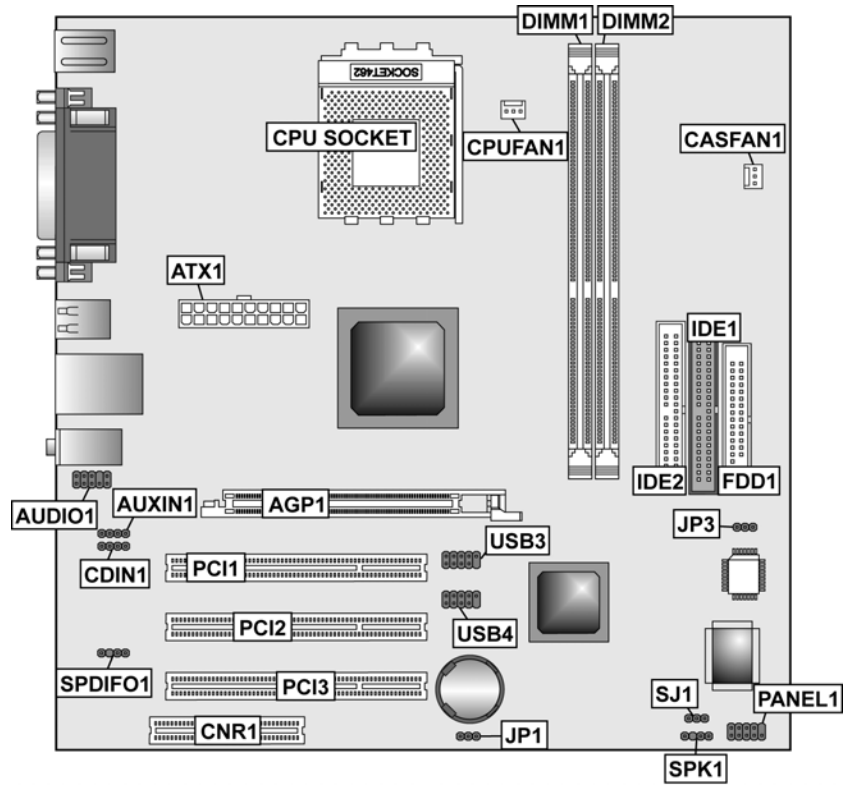

Table of Motherboard Components

Label	Component
AGP1	Accelerated Graphics Port (supports 1.5V AGP card only)
ATX1	Standard 20-pin ATX power connector
AUDIO1	Front Panel Audio header
AUXIN1	Auxiliary-in header
BAT1	Three volt realtime clock battery
CASFAN1	Case fan connector
CDIN1	Primary CD-in connector
CNR1	Communications Networking Riser slot
CPU Socket	Socket A for AMD CPU
CPUFAN1	Cooling fan for CPU
DIMM1 ~ DIMM2	Two 184-pin DDR SDRAM
FDD1	Floppy disk drive connector
IDE 1	Primary IDE channel
IDE 2	Secondary IDE channel
JP1	Clear CMOS jumper
JP3	BIOS Protect jumper
PANEL1	Connector for case front panel switches and LED indicators
PCI1 ~ PCI3	Three 32-bit add-on card slots
SJ1	Single color LED header
SPK1	Speaker connector
USB3/USB4	Header for front panel USB ports

This concludes Chapter 1. The next chapter explains how to install the motherboard.

Chapter 2

Installing the Motherboard

Safety Precautions

Follow these safety precautions when installing the motherboard:

- Wear a grounding strap attached to a grounded device to avoid damage from static electricity.
- Discharge static electricity by touching the metal case of a safely grounded object before working on the motherboard.
- Leave components in the static-proof bags they came in.
- Hold all circuit boards by the edges. Do not bend circuit boards.

Quick Guide

This Quick Guide suggests the steps you can take to assemble your system with the motherboards.

The following table provides a reference for installing specific components:

Locating Motherboard Components	Go to page 5
Installing the Motherboard in a Case	Go to page 8
Setting Jumpers	Go to page 8
Installing Case Components	Go to page 10
Installing the CPU	Go to page 13
Installing Memory	Go to page 16
Installing a HDD and CD-ROM Drive	Go to page 17
Installing an FDD	Go to page 18
Installing Add-on Cards	Go to page 19
Connecting Options	Go to page 21
Connecting Peripheral (I/O) Devices	Go to page 23

Installing the Motherboard in a Case

Refer to the following illustration and instructions for installing the motherboard in a case:

This illustration shows an example of a motherboard being installed in a tower-type case:

Note: Do not overtighten the screws as this can stress the motherboard.

Most system cases have mounting brackets installed in the case, which correspond to the holes in the motherboard. Place the motherboard over the mounting brackets and secure the motherboard onto the mounting brackets with screws.

2. Secure the mainboard with screws where appropriate.

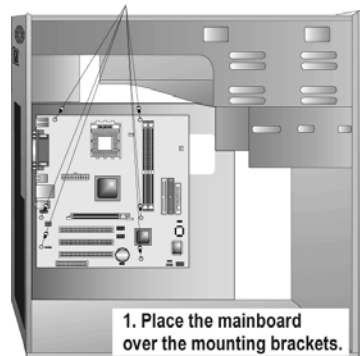

Ensure that your case has an I/O template that supports the I/O ports and expansion slots on your motherboard.

Checking Jumper Settings

This section explains how to set jumpers for correct configuration of the motherboard.

Setting Jumpers

Use the motherboard jumpers to set system configuration options. Jumpers with more than one pin are numbered. When setting the jumpers, ensure that the jumper caps are placed on the correct pins.

The illustrations below show a 2-pin jumper. When the jumper cap is placed on both pins, the jumper is SHORT. If you remove the jumper cap, or place the jumper cap on just one pin, the jumper is OPEN.

This illustration shows a 3-pin jumper. Pins 1 and 2 are SHORT.

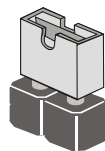

Short

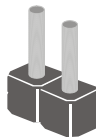

Open

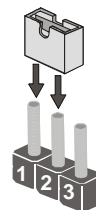

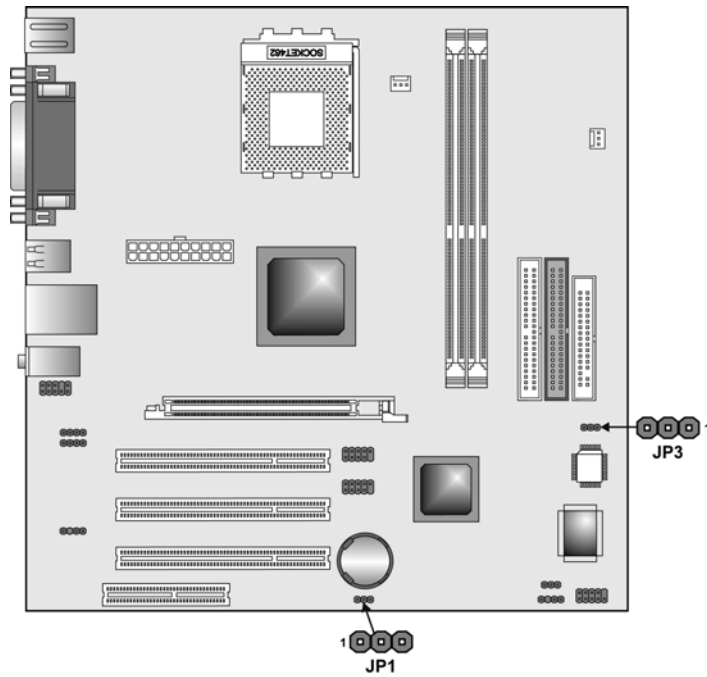

Checking Jumper Settings

The following illustration shows the location of the motherboard jumpers. Pin 1 is labeled.



Jumper Settings

Jumper	Type	Description	Setting (default)
JP1	3-pin	Clear CMOS	1-2: Normal 2-3: Clear CMOS Before clearing CMOS, make sure to turn off the system. 
JP3	3-pin	BIOS Protect	1-2: Disable 2-3: Enable 

Connecting Case Components

After you have installed the motherboard into a case, you can begin connecting the motherboard components. Refer to the following:

<ol style="list-style-type: none"> 1. Connect the CPU cooling fan cable to CPUFAN1. 2. Connect the case cooling fan connector to CASFAN1. 3. Connect the case speaker cable to SPEAKER1. 4. Connect the case switches and indicator to PANEL1. 5. Connect the case LED cable to SJ1. 6. Connect the standard power supply connector to ATX1. 	<p>The diagram shows a top-down view of a motherboard with several connectors labeled. CPUFAN1 is a 3-pin connector near the CPU. CASFAN1 is a 3-pin connector on the right side. ATX1 is a 20-pin connector on the left side. SPEAKER1 is a 4-pin connector at the bottom center. SJ1 is a 2-pin connector at the bottom left. PANEL1 is a 10-pin connector at the bottom right.</p>
--	---

CPUFAN1/CASFAN1: FAN Power Connectors

Pin	Signal Name	Function
1	GND	System Ground
2	+12V	Power +12V
3	Sense	Sensor

ATX1: ATX 20-pin Power Connector

Pin	Signal Name	Pin	Signal Name
1	+3.3V	11	+3.3V
2	+3.3V	12	-12V
3	Ground	13	Ground
4	+5V	14	PS ON#
5	Ground	15	Ground
6	+5V	16	Ground
7	Ground	17	Ground
8	PWRGD	18	-5V
9	+5VSB	19	+5V
10	+12V	20	+5V

SJ1: Single color LED header

Pin	Signal Name	Function
1	ACPI LED	MSG LED (-) green
2	ACPI LED	MSG LED (-) green
3	SB5V	Power LED (+)

ACPI LED function:

SJ1  1	S0	S1	S3	S4/S5
	Light	Blinking	Blinking	Dark

SPK1: Internal speaker

Pin	Signal Name
1	Signal
2	Key
3	Ground
4	VCC

Front Panel Connector

The front panel connector (PANEL1) provides a standard set of switch and LED connectors commonly found on ATX or micro-ATX cases. Refer to the table below for information:

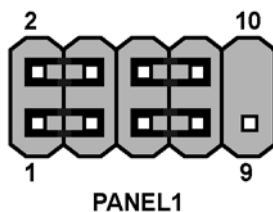

Pin	Signal	Function	Pin	Signal	Function
1	HD_LED_P	Hard disk LED (positive)	2	FP PWR/SLP	MSG LED [dual color or single color (+)]
3	HD_LED_N	Hard disk active LED (negative)	4	FP PWR/SLP	MSG LED [dual color or single color (-)]
5	RST_SW_N	Reset Switch	6	PWR_SW_P	Power Switch
7	RST_SW_P	Reset Switch	8	PWR_SW_N	Power Switch
9	RSVD	Reserved	10	NC	No pin

Hard Drive Activity LED

Connecting pins 1 and 3 to a front panel mounted LED provides visual indication that data is being read from or written to the hard drive. For the LED to function properly, an IDE drive should be connected to the onboard IDE interface. The LED will also show activity for devices connected to the SCSI (hard drive activity LED) connector.

Power / Sleep / Message Waiting LED

Connecting pins 2 and 4 to a single- or dual-color, front panel mounted LED provides power on/off, sleep, and message waiting indication.

Reset Switch

Supporting the reset function requires connecting pins 5 and 7 to a momentary-contact switch that is normally open. When the switch is closed, the board resets and runs POST.

Power Switch

Supporting the power on/off function requires connecting pins 6 and 8 to a momentary-contact switch that is normally open. The switch should maintain contact for at least 50 ms to signal the power supply to switch on or off. The time requirement is due to internal debounce circuitry. After receiving a power on/off signal, at least two seconds elapses before the power supply recognizes another on/off signal.

Installing Hardware

Installing the Processor

Caution: When installing a CPU heatsink and cooling fan make sure that you DO NOT scratch the motherboard or any of the surface-mount resistors with the clip of the cooling fan. If the clip of the cooling fan scrapes across the motherboard, you may cause serious damage to the motherboard or its components.

On most motherboards, there are small surface-mount resistors near the processor socket, which may be damaged if the cooling fan is carelessly installed.

Avoid using cooling fans with sharp edges on the fan casing and the clips. Also, install the cooling fan in a well-lit work area so that you can clearly see the motherboard and processor socket.

Before installing the Processor

This motherboard automatically determines the CPU clock frequency and system bus frequency for the processor. You may be able to change these settings by making changes to jumpers on the motherboard, or changing the settings in the system Setup Utility. We strongly recommend that you do not overclock processors or other components to run faster than their rated speed.

Warning: Overclocking components can adversely affect the reliability of the system and introduce errors into your system. Overclocking can permanently damage the motherboard by generating excess heat in components that are run beyond the rated limits.

This motherboard has a Socket 462 processor socket. When choosing a processor, consider the performance requirements of the system. Performance is based on the processor design, the clock speed and system bus frequency of the processor, and the quantity of internal cache memory and external cache memory.

CPU Installation Procedure

This motherboard is built with Socket 462 processor socket. When choosing a processor, consider the performance requirements of the system. The following illustration shows CPU installation components:

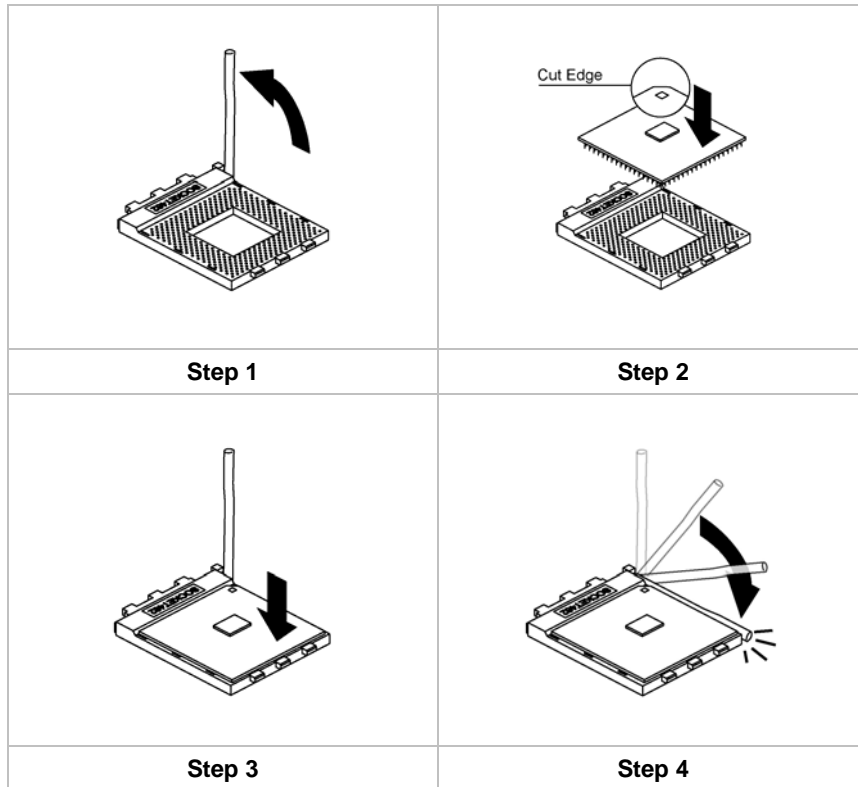

Orient the CPU so the odd corner matches the odd corner of the socket. With the lever in an upright position, gently place the CPU on the socket; make sure that all pins line up with the socket holes. When pins are aligned, the CPU should seat itself in the socket. Apply very light pressure to ensure the CPU is evenly seated. Push the lever down and ensure it latches firmly.

Note: Remember to apply thermal grease on top of the CPU.

Installing CPU Fan and Fan Connector

CPU fan and heatsink installation procedures may vary with the type of CPU fan/heatsink supplied. The form and size of fan/heatsink may also vary. Without an effective cooling fan, the CPU can overheat and cause damage to both CPU and the motherboard.

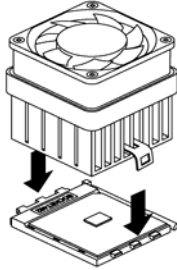
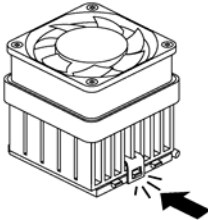
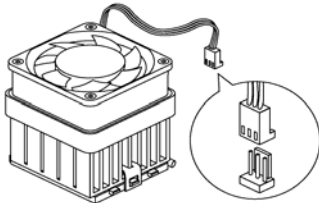
<p>1. Lower the CPU cooling fan/heatsink assembly onto the CPU.</p>	 A line drawing showing a square CPU cooling fan/heatsink assembly being lowered onto a CPU socket. Two black arrows point downwards from the assembly towards the socket, indicating the direction of movement.
<p>2. Secure the two retention clips on either side of the fan/heatsink unit onto the Socket 462 base.</p>	 A line drawing of the CPU cooling fan/heatsink assembly. Two black arrows point to the retention clips on either side of the fan/heatsink unit, indicating where they should be secured onto the Socket 462 base.
<p>3. Connect the CPU Cooling Fan power cable connector to the CPUFAN connector.</p>	 A line drawing of the CPU cooling fan/heatsink assembly. A power cable is connected to the fan. A circular inset shows a close-up of the power cable connector being inserted into the CPUFAN connector on the motherboard.

Installing Memory Modules

This motherboard accommodates two 184-pin 2.5V unbuffered Double Data Rate (DDR) SDRAM memory modules. It can support DDR333/DDR266 memory modules; you must install at least one module in any of the two slots. Each module can be installed with 32 MB to 1 GB of memory; total memory capacity is 2GB.



Do not remove any memory module from its antistatic packaging until you are ready to install it on the motherboard. Handle the modules only by their edges. Do not touch the components or metal parts. Always wear a grounding strap when you handle the modules.

Refer to the following to install the memory modules.

1. This motherboard supports unbuffered DDR SDRAM only.

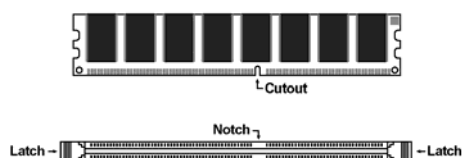

2. Push the latches on each side of the DIMM slot down.
3. Align the memory module with the slot. The DIMM slots are keyed with notches and the DIMMs are keyed with cutouts so that they can only be installed correctly.

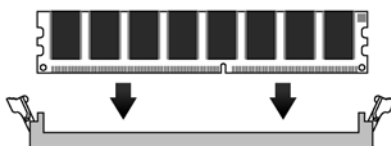

4. Check that the cutouts on the DIMM module edge connector match the notches in the DIMM slot.
5. Install the DIMM module into the slot and press it firmly down until it seats correctly. The slot latches are levered upwards and latch on to the edges of the DIMM.



6. Install any remaining DIMM modules.

Installing a Hard Disk Drive/CD-ROM

This section describes how to install IDE devices such as a hard disk drive and a CD-ROM drive.

Your motherboard has a primary and secondary IDE channel interface (IDE1 and IDE2). An IDE ribbon cable supporting two IDE devices is bundled with the motherboard.

If you want to install more than two IDE devices, get a second IDE cable and you can add two more devices to the secondary IDE channel.

IDE1: Primary IDE Connector

The first hard drive should always be connected to IDE1.

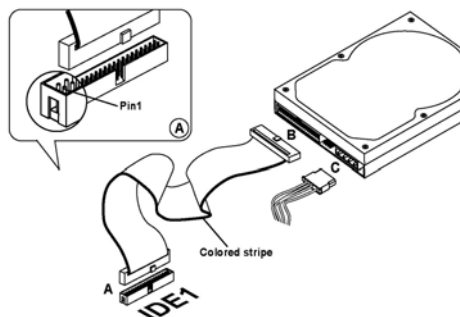

IDE2: Secondary IDE

The second drive on this controller must be set to slave mode. The configuration is the same as IDE1.

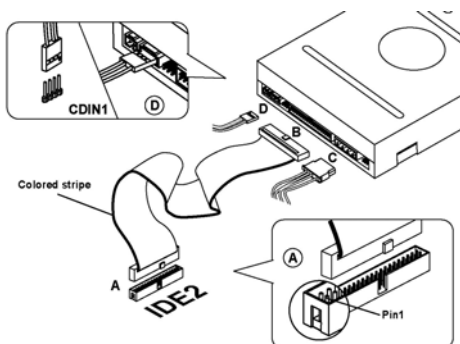

You must orient the cable connector so that the pin 1 (color) edge of the cable corresponds to the pin 1 of the I/O port connector.

IDE devices have jumpers or switches that are used to set the IDE device as MASTER or SLAVE. Refer to the IDE device user's manual. When installing two IDE devices on one cable, ensure that one device is set to MASTER and the other device is set to SLAVE. The documentation of your IDE device explains how to do this.

About UltraDMA

This motherboard supports UltraDMA 66/100/133. UDMA is a technology that accelerates the performance of devices in the IDE channel. To maximize performance, install IDE devices that support UDMA and use 80-pin IDE cables that support UDMA 66/100/133.

Installing a Floppy Diskette Drive

The motherboard has a floppy diskette drive (FDD) interface and ships with a diskette drive ribbon cable that supports one or two floppy diskette drives. You can install a 5.25-inch drive and a 3.5-inch drive with various capacities. The floppy diskette drive cable has one type of connector for a 5.25-inch drive and another type of connector for a 3.5-inch drive.

FDD1: Floppy Disk Connector

This connector supports the provided floppy drive ribbon cable. After connecting the single end to the onboard floppy connector, connect the remaining plugs on the other end to the floppy drives correspondingly.

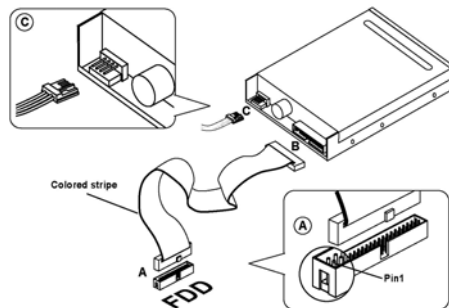

You must orient the cable connector so that the pin 1 (color) edge of the cable corresponds to the pin 1 of the I/O port connector.

Installing Add-on Cards

The slots in this motherboard are designed to hold expansion cards and connect them to the system bus. Expansion slots are a means of adding or enhancing the motherboard's features and capabilities. With these efficient facilities, you can increase the motherboard's capabilities by adding hardware which performs tasks that are not part of the basic system.

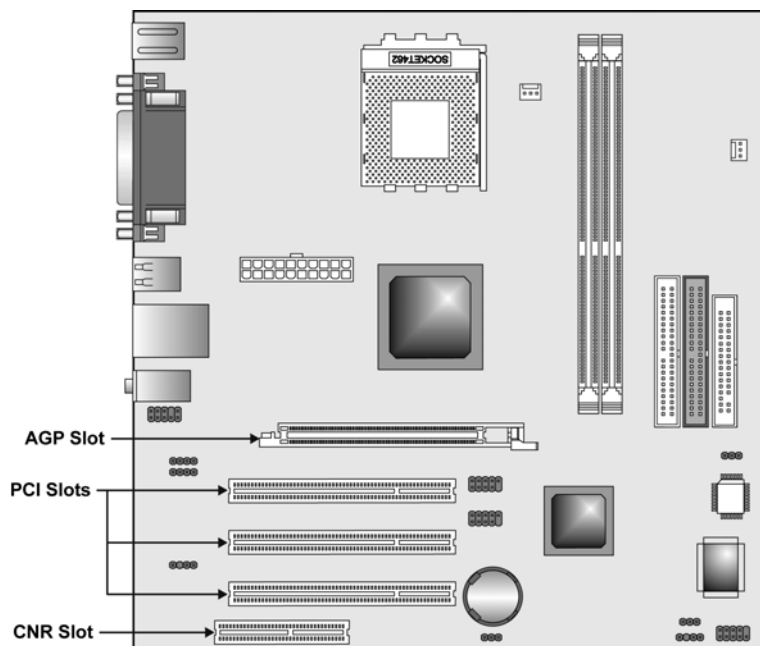

- AGP Slot** The AGP slot is used to install 3D graphics adapter that supports the 8X AGP card which is also backward compatible with 4X AGP card. The slot is keyed to support only the latest 1.5-volt AGP cards.
- PCI Slots** PCI slots are used to install expansion cards that have the 32-bit PCI interface.
- CNR Slot** This slot is used to insert CNR cards with Modem and Audio functionality.

Note: Before installing an add-on card, check the documentation for the card carefully. If the card is not Plug and Play, you may have to manually configure the card before installation.

Follow these instructions to install an add-on card:

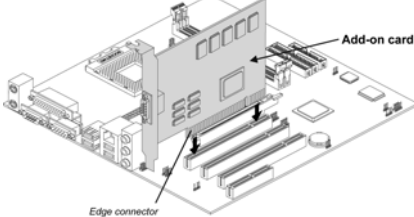
1. Remove a blanking plate from the system case corresponding to the slot you are going to use.	
2. Install the edge connector of the add-on card into the expansion slot. Ensure that the edge connector is correctly seated in the slot.	 An isometric diagram of a motherboard with an expansion slot. An add-on card is shown being inserted into the slot. The card is labeled 'Add-on card' and the slot is labeled 'Edge connector'. The card has a metal bracket on its side that fits into the slot. The motherboard has various other components like RAM, capacitors, and other slots visible.
3. Secure the metal bracket of the card to the system case with a screw.	

Note: For some add-on cards, for example graphics adapters and network adapters, you have to install drivers and software before you can begin using the add-on card.

Connecting Optional Devices

Refer to the following for information on connecting the motherboard's optional devices:

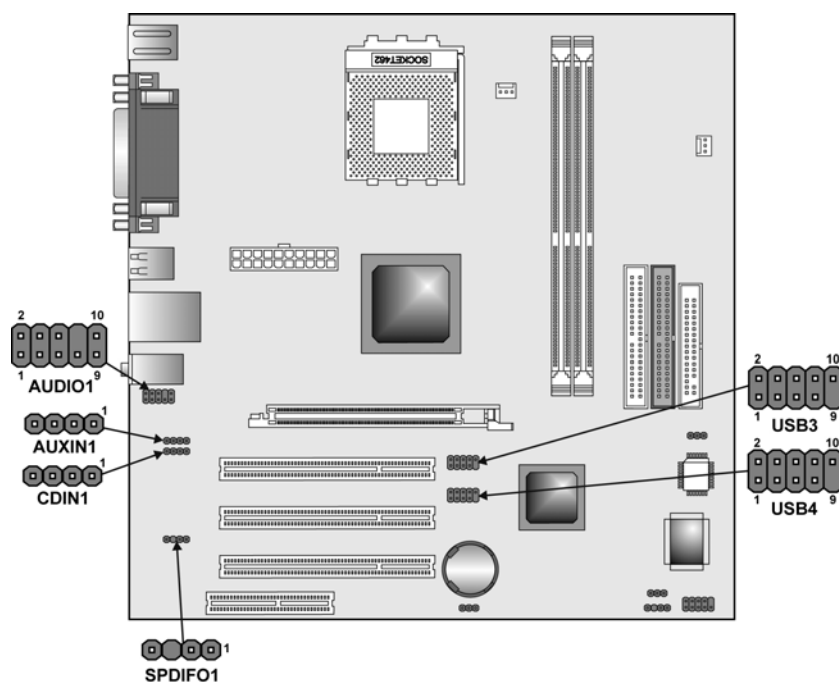

AUDIO1: Front Panel Audio header

This header allows the user to install auxiliary front-oriented microphone and line-out ports for easier access.

Pin	Signal Name	Function
1	AUD_MIC	Front Panel Microphone input signal
2	AUD_GND	Ground used by Analog Audio Circuits
3	AUD_MIC_BIAS	Microphone Power
4	AUD_VCC	Filtered +5 V used by Analog Audio Circuits
5	AUD_FPOUT_R	Right Channel Audio signal to Front Panel
6	AUD_RET_R	Right Channel Audio signal to Return from Front Panel
7	HP_ON	Reserved for future use to control Head-phone Amplifier
8	KEY	No Pin
9	AUD_FPOUT_L	Left Channel Audio signal to Front Panel
10	AUD_RET_L	Left Channel Audio signal Return from Front Panel

USB3/USB4: Front panel USB headers

The motherboard has four USB ports installed on the rear edge I/O port array. Additionally, some computer cases have USB ports at the front of the case. If you have this kind of case, use auxiliary USB connectors USB3 or USB4 to connect the front-mounted ports to the motherboard.

Pin	Signal Name	Function
1	VREG_FP_USBPWR0	Front Panel USB Power
2	VREG_FP_USBPWR0	Front Panel USB Power
3	USB_FP_P0-	USB Port 0 Negative Signal
4	USB_FP_P1-	USB Port 1 Negative Signal
5	USB_FP_P0+	USB Port 0 Positive Signal
6	USB_FP_P1+	USB Port 1 Positive Signal
7	GND	Ground
8	GND	Ground
9	KEY	No pin
10	NC	Not connected

Note: Please make sure that the USB cable has the same pin assignment as indicated above. A different pin assignment may cause damage or system hang-up.

SPDIF01: SPDIF out header

This is an optional header that provides an S/PDIF (Sony/Philips Digital Interface) output to digital multimedia device through optical fiber or coaxial connector.

Pin	Signal Name
1	SPDIF Out
2	VCC
3	KEY
4	GND

AUXIN1: Auxiliary-in header

This connector is an additional line-in audio connector. It allows you to attach a line-in cable when your rear line-in jack is set as line out port for 4-channel function.

Pin	Signal Name	Function
1	AUX_L	AUX In left channel
2	GND	Ground
3	GND	Ground
4	AUX_R	AUX In right channel

CDIN1: CD Audio Input header

Pin	Signal Name	Function
1	CD in_L	CD In left channel
2	GND	Ground
3	GND	Ground
4	CD in_R	CD In right channel

Connecting I/O Devices

The backplane of the motherboard has the following I/O ports:

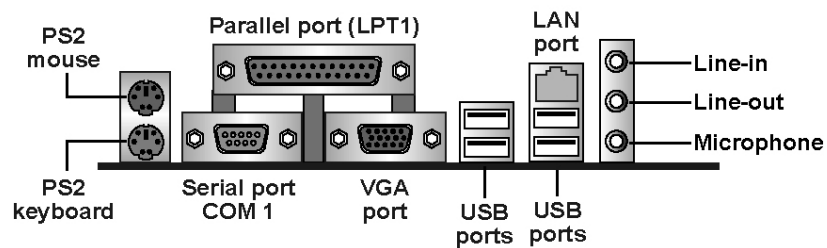

- PS/2 Mouse** Use the upper PS/2 port to connect a PS/2 pointing device.
- PS/2 Keyboard** Use the lower PS/2 port to connect a PS/2 keyboard.
- LPT1** Use LPT1 to connect printers or other parallel communications devices.
- Serial Port (COM1)** Use the COM ports to connect serial devices such as mice or fax/modems.
- VGA Port** Connect your monitor to the VGA port.
- Audio Ports** Use the three audio ports to connect audio devices. The first jack is for stereo line-in signal. The second jack is for stereo line-out signal. The third jack is for microphone.
- LAN Port (optional)** Connect an RJ-45 jack to the LAN port to connect your computer to the Network.
- USB Ports** Use the USB ports to connect USB devices.

This concludes Chapter 2. The next chapter covers the BIOS.

Chapter 3

Using BIOS

About the Setup Utility

The computer uses the latest Award BIOS with support for Windows Plug and Play. The CMOS chip on the motherboard contains the ROM setup instructions for configuring the motherboard BIOS.

The BIOS (Basic Input and Output System) Setup Utility displays the system's configuration status and provides you with options to set system parameters. The parameters are stored in battery-backed-up CMOS RAM that saves this information when the power is turned off. When the system is turned back on, the system is configured with the values you stored in CMOS.

The BIOS Setup Utility enables you to configure:

- Hard drives, diskette drives, and peripherals
- Video display type and display options
- Password protection from unauthorized use
- Power management features

The settings made in the Setup Utility affect how the computer performs. Before using the Setup Utility, ensure that you understand the Setup Utility options.

This chapter provides explanations for Setup Utility options.

The Standard Configuration

A standard configuration has already been set in the Setup Utility. However, we recommend that you read this chapter in case you need to make any changes in the future.

This Setup Utility should be used:

- when changing the system configuration
- when a configuration error is detected and you are prompted to make changes to the Setup Utility
- when trying to resolve IRQ conflicts
- when making changes to the Power Management configuration
- when changing the password or making other changes to the Security Setup

Starting Setup

The BIOS is immediately activated when you first turn on the computer. The BIOS reads system configuration in CMOS RAM and begins the process of checking out the system and configuring it through the power-on self test (POST).

When these preliminaries are finished, the BIOS seeks an operating system on one of the data storage devices (hard drive, floppy drive, etc.). The BIOS launches the operating system and hands control of system operations to it.

During POST, you can start the Setup program in one of two ways:

1. By pressing Del immediately after switching the system on, or
2. By pressing Del or pressing Ctrl+Alt+Esc when the following message appears briefly at the bottom of the screen during POST:

TO ENTER SETUP BEFORE BOOT PRESS DEL KEY

If the message disappears before you respond and you still wish to enter Setup, restart the system to try again by turning it OFF then ON or pressing the RESET button on the system case. You may also restart by simultaneously pressing Ctrl+Alt+Del. If you do not press the keys at the correct time and the system does not boot, an error message appears and you are again asked to:

PRESS F1 TO CONTINUE, DEL TO ENTER SETUP

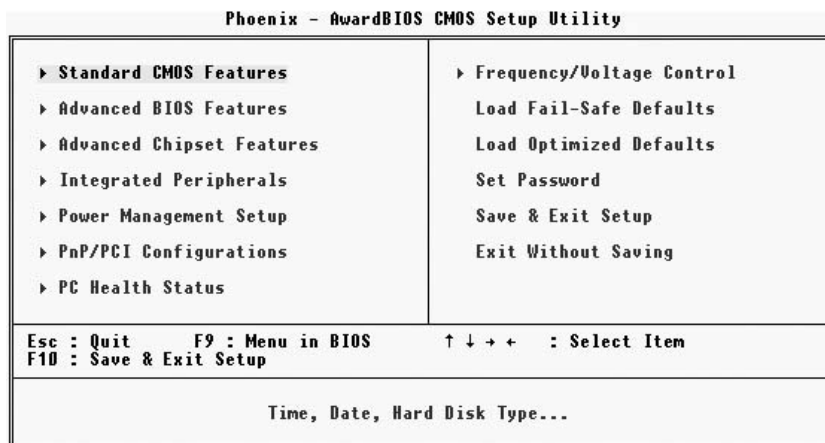

BIOS Navigation Keys

The BIOS navigation keys are listed below:

Key	Function
Esc	Exits the current menu
←↑↓→	Scrolls through the items on a menu
+/-/PU/PD	Modifies the selected field's values
F10	Saves the current configuration and exits setup
F1	Displays a screen that describes all key functions
F5	Loads previously saved values to CMOS
F6	Loads a minimum configuration for troubleshooting.
F7	Loads an optimum set of values for peak performance

Updating the BIOS

You can download and install updated BIOS for this motherboard from the manufacturer's Web site. New BIOS provides support for new peripherals, improvements in performance, or fixes for known bugs. Install new BIOS as follows:

1. If your motherboard has a BIOS protection jumper, change the setting to allow BIOS flashing.
2. If your motherboard has an item called Firmware Write Protect in Advanced BIOS features, disable it. (Firmware Write Protect prevents BIOS from being overwritten.)
3. Create a bootable system disk. (Refer to Windows online help for information on creating a bootable system disk.)
4. Download the Flash Utility and new BIOS file from the manufacturer's Web site. Copy these files to the system diskette you created in Step 3.
5. Turn off your computer and insert the system diskette in your computer's diskette drive. (You might need to run the Setup Utility and change the boot priority items on the Advanced BIOS Features Setup page, to force your computer to boot from the floppy diskette drive first.)
6. At the A:\ prompt, type the Flash Utility program name and press <Enter>. You see a screen similar to the following:

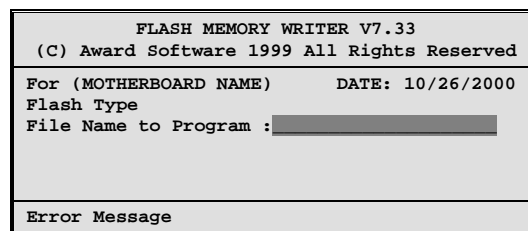

7. Type the filename of the new BIOS in the "File Name to Program" text box. Follow the onscreen directions to update the motherboard BIOS.

8. When the installation is complete, remove the floppy diskette from the diskette drive and restart your computer. If your motherboard has a Flash BIOS jumper, reset the jumper to protect the newly installed BIOS from being overwritten.

Using BIOS

When you start the Setup Utility, the main menu appears. The main menu of the Setup Utility displays a list of the options that are available. A highlight indicates which option is currently selected. Use the cursor arrow keys to move the highlight to other options. When an option is highlighted, execute the option by pressing <Enter>.

Some options lead to pop-up dialog boxes that prompt you to verify that you wish to execute that option. Other options lead to dialog boxes that prompt you for information.

Some options (marked with a triangle ►) lead to submenus that enable you to change the values for the option. Use the cursor arrow keys to scroll through the items in the submenu.

In this manual, default values are enclosed in parenthesis. Submenu items are denoted by a triangle ►.

Standard CMOS Features

In the Standard CMOS menu you can set the system clock and calendar, record disk drive parameters and the video subsystem type, and select the type of errors that stop the BIOS POST.

Phoenix - AwardBIOS CMOS Setup Utility		
Standard CMOS Features		
Date (mm:dd:yy)	Fri, Nov 21 2003	Item Help
Time (hh:mm:ss)	10 : 30 : 51	Menu Level ►
► IDE Primary Master		Change the day, month, year and century
► IDE Primary Slave		
► IDE Secondary Master		
► IDE Secondary Slave		
Drive A	[1.44M, 3.5 in.]	
Drive B	[None]	
Floppy 3 Mode Support	[Disabled]	
Video	[EGA/VGA]	
Halt On	[All Errors]	
Base Memory	640K	
Extended Memory	65535K	
Total Memory	1024K	
↑↓←→:Move Enter:Select +/-/PU/PD:Value F10:Save ESC:Exit F1:General Help F5: Previous Values F6: Fail-Safe Defaults F7: Optimized Defaults		

Date and Time

The Date and Time items show the current date and time on the computer. If you are running a Windows OS, these items are automatically updated whenever you make changes to the Windows Date and Time Properties utility.

► IDE Devices (None)

Your computer has two IDE channels (Primary and Secondary) and each channel can be installed with one or two devices (Master and Slave). Use these items to configure each device on the IDE channel.

Press <Enter> to display the IDE submenu:

Phoenix - AwardBIOS CMOS Setup Utility		Item Help
IDE HDD Auto-Detection	[Press Enter]	Menu Level >>
IDE Channel 0 Slave Access Mode	[Auto]	To auto-detect the HDD's size, head... on this channel
Capacity	0 MB	
Cylinder	0	
Head	0	
Precomp	0	
Landing Zone	0	
Sector	0	

↑↓←→:Move Enter:Select +/-/PU/PD:Value F10:Save ESC:Exit F1:General Help
F5: Previous Values F6: Fail-Safe Defaults F7: Optimized Defaults

IDE HDD Auto-Detection

Press <Enter> while this item is highlighted to prompt the Setup Utility to automatically detect and configure an IDE device on the IDE channel.

Note: If you are setting up a new hard disk drive that supports LBA mode, more than one line will appear in the parameter box. Choose the line that lists LBA for an LBA drive.

IDE Primary/Secondary Master/Slave (Auto)

Leave this item at Auto to enable the system to automatically detect and configure IDE devices on the channel. If it fails to find a device, change the value to Manual and then manually configure the drive by entering the characteristics of the drive in the items described below.

Refer to your drive's documentation or look on the drive casing if you need to obtain this information. If no device is installed, change the value to None.

Note: Before attempting to configure a hard disk drive, ensure that you have the configuration information supplied by the manufacturer of your hard drive. Incorrect settings can result in your system not recognizing the installed hard disk.

Access Mode

This item defines ways that can be used to access IDE hard disks such as LBA (Large Block Addressing). Leave this value at Auto and the system will automatically decide the fastest way to access the hard disk drive.

Press <Esc> to return to the Standard CMOS Setup screen.

Drive A/Drive B (1.44M, 3.5 in.)

These items define the characteristics of any diskette drive attached to the system. You can connect one or two diskette drives.

Floppy 3 Mode Support (Disabled)

Floppy 3 mode refers to a 3.5-inch diskette with a capacity of 1.2 MB. Floppy 3 mode is sometimes used in Japan.

Video (EGA/VGA)

This item defines the video mode of the system. This motherboard has a built-in VGA graphics system; you must leave this item at the default value.

Halt On (All Errors)

This item defines the operation of the system POST (Power On Self Test) routine. You can use this item to select which types of errors in the POST are sufficient to halt the system.

Base Memory, Extended Memory, and Total Memory

These items are automatically detected by the system at start up time. These are display-only fields. You cannot make changes to these fields.

Advanced BIOS Features

This screen contains industry-standard options additional to the core PC AT BIOS.

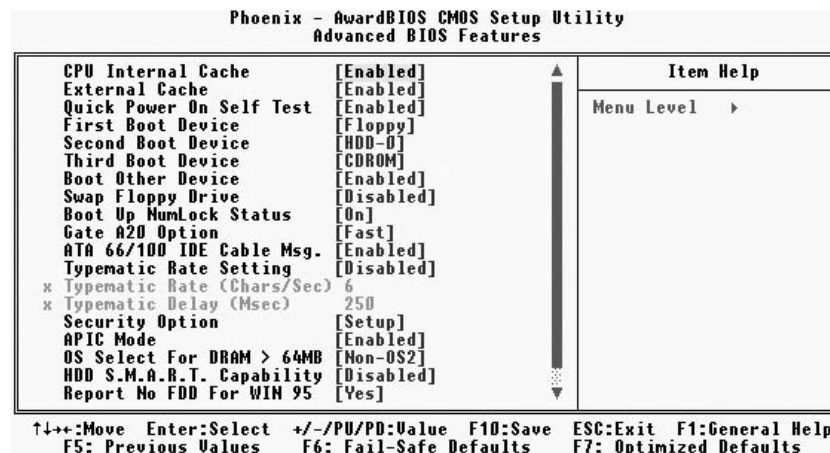

CPU Internal Cache (Enabled)

The function of the internal cache is to store data and instructions that have been read from the main memory and are written back to the cache for faster access in case they are requested again.

External Cache (Enabled)

This option sets the type of caching algorithm used by the L1 external cache memory on the CPU.

Quick Power On Self Test (Enabled)

This item allows you to decrease the time it takes to boot up the computer by shortening or skipping certain standard booting procedures. If set to enabled, the BIOS will shorten the booting process by skipping some tests and shortening others.

First Boot Device/Second Boot Device/Third Boot Device (Floppy/HDD-0/CDROM)

Use these items to determine the device order the computer uses to look for an operating system to load at start-up time.

Boot Other Device (Enabled)

If you enable this item, the system will also search for other boot devices if it fails to find an operating system from the first two locations.

Swap Floppy Drive (Disabled)

This item allows you to swap the logical arrangement of the floppy drives. Instead of opening up the motherboard case to do it physically, you can set this item to Enabled. Then the first drive will be mapped as drive B: and the second drive, mapped as drive A:, which is the opposite of the usual convention.

Boot Up NumLock Status (On)

Set this option to Off to turn the Num Lock key off when the computer is booted you can use the arrow keys in both the numeric keypad and the keyboard.

Gate A20 Option (Fast)

This item determines how Gate A20 is used to address memory above 1MB. When this option is set to Fast, the motherboard chipset controls the operation of Gate A20. But when set to Normal, a pin in the keyboard controller controls Gate A20. Setting Gate A20 to Fat improves memory access speed and thus, overall system speed, especially with OS/2 and Windows.

ATA 66/100 IDE Cable Msg. (Enabled)

Enables or disables the ATA 66/100 IDE Cable Msg. This message will appear during reboot when you use 40-pin cable on your 66/100 hard disks.

Typematic Rate Setting (Disabled)

If this item is enabled, you can use the following two items to set the typematic rate and the typematic delay settings for your keyboard.

- **Typematic Rate (6):** Use this item to define how many characters per second are generated by a held-down key.
- **Typematic Delay (250):** Use this item to define how many milliseconds must elapse before a held-down key begins generating repeat characters.

Security Option (Setup)

If you have installed password protection, this item defines if the password is required at system start up, or if it is only required when a user tries to enter the Setup Utility.

APIC Mode (Enabled)

This item allows you to enable APIC (Advanced Programmable Interrupt Controller) functionality. APIC is an Intel chip that provides symmetric multiprocessing (SMP) for its Pentium systems.

OS Select For DRAM > 64 MB (Non-OS2)

This item is only required if you have installed more than 64 MB of memory and you are running the OS/2 operating system. Otherwise, leave this item at the default.

HDD S.M.A.R.T Capability (Disabled)

The S.M.A.R.T. (Self-Monitoring, Analysis, and Reporting Technology) system is a diagnostics technology that monitors and predicts device performance. S.M.A.R.T. software resides on both the disk drive and the host computer.

The disk drive software monitors the internal performance of the motors, media, heads, and electronics of the drive. The host software monitors the overall reliability status of the drive. If a device failure is predicted, the host software, through the Client WORKS S.M.A.R.T applet, warns the user of the impending condition and advises appropriate action to protect the data.

Report No FDD For WIN 95 (Yes)

If you are running a system with no floppy drive and using Windows 95, select Yes for this item to ensure compatibility with the Windows 95 logo certification. Otherwise, select No.

Video BIOS Shadow (Enabled)

This item determines whether the BIOS will be copied to RAM for faster execution.

Small Logo (EPA) Show (Disabled)

Enables or disables the display of the EPA logo during boot.

Advanced Chipset Setup

The parameters in this screen are for system designers, service personnel, and technically competent users only. Do not reset these values unless you understand the consequences of your changes.

Phoenix - AwardBIOS CMOS Setup Utility		
Advanced Chipset Features		
> AGP & P2P Bridge Control	[Press Enter]	Item Help
> OnChip AGP Control	[Press Enter]	
System BIOS Cacheable	[Disabled]	Menu Level >
Video RAM Cacheable	[Disabled]	

↑↓→←:Move Enter:Select +/-/PU/PD:Value F10:Save ESC:Exit F1:General Help
F5: Previous Values F6: Fail-Safe Defaults F7: Optimized Defaults

► AGP & P2P Bridge Control

Scroll to this item and press <Enter> to view the following screen:

Phoenix - AwardBIOS CMOS Setup Utility		
AGP & P2P Bridge Control		
AGP Aperture Size	[128MB]	Item Help
AGP Fast Write Support	[Disabled]	
AGP Data Transfer Rate	[Auto]	Menu Level >>

↑↓→←:Move Enter:Select +/-/PU/PD:Value F10:Save ESC:Exit F1:General Help
F5: Previous Values F6: Fail-Safe Defaults F7: Optimized Defaults

AGP Aperture Size (128MB)

This item defines the size of the aperture if you use an AGP graphics adapter. It refers to a section of the PCI memory address range used for graphics memory. We recommend that you leave this item at the default value.

AGP Fast Write Support (Disabled)

This item controls the AGP bus Fast Write capability. Fast Write allows the AGP device to act like a PCI device. This allows it to skip the main memory and directly access the data that improves the AGP read performance.

AGP Data Transfer Rate (Auto)

You can select the AGP device data transfer rate capability.

Press <Esc> to return to the Advanced Chipset Setup screen.

► **OnChip AGP Control**

Scroll to this item and press <Enter> to view the following screen:

Phoenix - AwardBIOS CMOS Setup Utility		
OnChip AGP Control		
Dual Display Support	[Disabled]	Item Help
VGA Share Memory Size	[32 MB]	Menu Level >>
Graphics Engin Clock	[133MHz]	

↑↓←→:Move Enter:Select +/-/PU/PD:Value F10:Save ESC:Exit F1:General Help
F5: Previous Values F6: Fail-Safe Defaults F7: Optimized Defaults

Dual Display Support (Disabled)

This item allows you to enable the Dual Display support.

VGA Share Memory Size (32 MB)

This item allows you to select the shared memory size for VGA usage.

Graphics Engin Clock (133 MHz)

This item reports the Graphics Engine Clock setting information to VGA BIOS. We recommend that you leave this item at the default value.

Press <Esc> to return to the Advanced Chipset Setup screen.

System BIOS Cacheable (Disabled)

This feature is only valid when the system BIOS is shadowed. It enables or disables the caching of the system BIOS ROM at **F0000h-FFFFFh** via the L2 cache. This greatly speeds up accesses to the system BIOS.

Video RAM Cacheable (Disabled)

This feature enables or disables the caching of the video RAM at **A0000h-AFFFFh** via the L2 cache.

Integrated Peripherals

These options display items that define the operation of peripheral components on the system's input/output ports.

Phoenix - AwardBIOS CMOS Setup Utility Integrated Peripherals		
▶ SIS OnChip IDE Device	[Press Enter]	Item Help
▶ SIS OnChip PCI Device	[Press Enter]	
▶ Onboard SuperIO Device	[Press Enter]	Menu Level ▶
IDE HDD Block Mode	[Enabled]	
Init Display First	[PCI Slot]	

↑↓←→:Move Enter:Select +/-/PU/PD:Value F10:Save ESC:Exit F1:General Help
F5: Previous Values F6: Fail-Safe Defaults F7: Optimized Defaults

▶ SIS OnChip IDE Device

Scroll to this item and press <Enter> to view the following screen:

Phoenix - AwardBIOS CMOS Setup Utility SIS OnChip IDE Device		
Internal PCI/IDE	[Both]	Item Help
IDE Primary Master PIO	[Auto]	
IDE Primary Slave PIO	[Auto]	Menu Level ▶▶
IDE Secondary Master PIO	[Auto]	
IDE Secondary Slave PIO	[Auto]	
Primary Master UltraDMA	[Auto]	
Primary Slave UltraDMA	[Auto]	
Secondary Master UltraDMA	[Auto]	
Secondary Slave UltraDMA	[Auto]	
IDE DMA transfer access	[Enabled]	
IDE Burst Mode	[Enabled]	

↑↓←→:Move Enter:Select +/-/PU/PD:Value F10:Save ESC:Exit F1:General Help
F5: Previous Values F6: Fail-Safe Defaults F7: Optimized Defaults

Internal PCI/IDE (Both)

Use these items to enable or disable the internal PCI IDE channels that are integrated on the motherboard.

IDE Primary/Secondary Master/Slave PIO (Auto)

Each IDE channel supports a master device and a slave device. These four items let you assign which kind of PIO (Programmed Input/Output) is used by IDE devices. Choose Auto to let the system auto detect which PIO mode is best, or select a PIO mode from 0-4.

Primary/Secondary Master/Slave UltraDMA (Auto)

This option allows you to enable or disable UltraDMA support (if available) for the two IDE devices (Master and Slave drives) attached to that particular IDE channel. Normally, you should leave it as Auto and let the BIOS auto-detect if the drive supports UltraDMA. If it does, the proper UltraDMA transfer mode will be enabled for that drive, allowing it to burst data at up to 100MB/s. You should only disable it for troubleshooting purposes.

Note: Setting this to Auto does not enable the UltraDMA or any of the slower DMA mode for IDE devices that do not support UltraDMA. Also, in order for any of those DMA modes to work (including UltraDMA modes), you will have to enable DMA transfer via the OS.

IDE DMA Transfer Access (Enabled)

This item allows you to enabled the transfer access of the IDE DMA.

IDE Burst Mode (Enabled)

This option, when enabled will instruct the system to send every write transaction to the write buffer. Burstable transactions then burst onto the PCI bus and nonburstable transactions do not.

Press <Esc> to return to the Integrated Peripherals screen.

► **SIS OnChip PCI Device**

Scroll to this item and press <Enter> to view the following screen:

Phoenix - AwardBIOS CMOS Setup Utility		Item Help
SIS OnChip PCI Device		Menu Level ▶▶
SIS USB Controller	[Enabled]	
USB Ports Number	[6 Ports]	
USB 2.0 Supports	[Enabled]	
USB Legacy Support	[Enabled]	
USB Mouse Support	[Enabled]	
SIS AC97 AUDIO	[Enabled]	
SIS S/w Modem	[Enabled]	
Onboard Lan Device	[Enabled]	
Onboard Lan Boot ROM	[Disabled]	

↑|←:Move Enter:Select +/-/PU/PD:Value F10:Save ESC:Exit F1:General Help
F5: Previous Values F6: Fail-Safe Defaults F7: Optimized Defaults

SIS USB Controller (Enabled)

This item enables the USB controller. Leave this at the default “Enabled” if you want to connect USB devices to your computer.

USB Ports Number (6 Ports)

This item enables you to determine the number of USB ports.

USB 2.0 Support (Enabled)

Enable this item if your system supports USB 2.0

USB Legacy Support (Enabled)

Use this item to enable or disable support for legacy USB devices. Setting to Auto allows the system to detect the presence of USB devices at startup. If detected, the USB controller legacy mode is enabled. If no USB device is detected, the legacy USB support is disabled.

USB Mouse Support (Disabled)

Enable this item if you plan to use a mouse connected through the USB port in a legacy operating system (such as DOS) that does not support Plug and Play.

SIS AC' 97 AUDIO (Enabled)

This option allows you to control the onboard AC' 97 audio. Disable this item if you are going to install a PCI audio add-on card.

SIS S/W Modem (Enabled)

This option allows you to control the onboard S/W modem. Disable this item if you are going to install an external modem.

Onboard LAN Device (Enabled)

This option allows you to control the onboard LAN device.

Onboard LAN Boot ROM (Disabled)

Use this item to enable and disable the booting from the onboard LAN or a network add-in card with a remote boot ROM installed.

Press <Esc> to return to the Integrated Peripherals screen.

► **Onboard Super IO Device**

Phoenix - AwardBIOS CMOS Setup Utility		Item Help
Onboard SuperIO Device		
Onboard FDC Controller	[Enabled]	
Onboard Serial Port 1	[3F8/IRQ4]	
Onboard Parallel Port	[378/IRQ7]	
Parallel Port Mode	[ECP]	Menu Level ▶▶
ECP Mode Use DMA	[3]	

↑↓←→:Move Enter:Select +/-/PU/PD:Value F10:Save ESC:Exit F1:General Help
 F5: Previous Values F6: Fail-Safe Defaults F7: Optimized Defaults

Onboard FDC Controller (Enabled)

Select Enabled if your system has a floppy disk controller (FDB) installed on the system board and you wish to use it. If you install an add-in FDC or the system has no floppy drive, select Disabled in this field.

Onboard Serial Port 1 (3F8/IRQ4)

This option is used to assign the I/O address and interrupt request (IRQ) for onboard serial port 1 (COM1).

Onboard Parallel Port (378/IRQ7)

This option is used to assign the I/O address and interrupt request (IRQ) for the onboard parallel port.

Parallel Port Mode (ECP)

Enables you to set the data transfer protocol for your parallel port. There are four options: SPP (Standard Parallel Port), EPP (Enhanced Parallel Port), ECP (Extended Capabilities Port) and ECP+EPP.

SPP allows data output only. Extended Capabilities Port (ECP) and Enhanced Parallel Port (EPP) are bi-directional modes, allowing both data input and output. ECP and EPP modes are only supported with EPP- and ECP-aware peripherals.

ECP Mode Use DMA (3)

When the onboard parallel port is set to ECP mode, the parallel port can use DMA 3 or DMA 1.

Press <Esc> to return to the Integrated Peripherals screen.

IDE HDD Block Mode (Enabled)

Enable this field if your IDE hard drive supports block mode. Block mode enables BIOS to automatically detect the optimal number of block read and writes per sector that the drive can support and improves the speed of access to IDE devices.

Init Display First (PCI Slot)

Use this item to specify whether your graphics adapter is installed in one of the PCI slots or is integrated on the motherboard.

Power Management Setup

The Power Management Setup Menu option is used to change the values of the chipset registers for system power management.

Power Management Timeouts

The power-saving modes can be controlled by timeouts. If the system is inactive for a time, the timeouts begin counting. If the inactivity continues so that the timeout period elapses, the system enters a power-saving mode. If any item in the list of Reload Global Timer Events is Enabled, then any activity on that item will reset the timeout counters to zero.

Wake Up Calls

If the system is suspended, or has been powered down by software, it can be resumed by a wake up call that is generated by incoming traffic to a modem, a LAN card, a PCI card, or a fixed alarm on the system realtime clock.

Phoenix - AwardBIOS CMOS Setup Utility		
Power Management Setup		
Suspend Mode	[Disabled]	Item Help
Video Off Option	[Susp,Stby -> Off]	
Video Off Method	[DPMS Supported]	Menu Level ▶
MODEM Use IRQ	[3]	
HDD Off After	[Disabled]	
Power Button Override	[Instant Off]	
Power On After Power Fail	[Always Off]	
▶ PM Wake Up Events	[Press Enter]	

↑↓←→:Move Enter:Select +/-/PU/PD:Value F10:Save ESC:Exit F1:General Help
F5: Previous Values F6: Fail-Safe Defaults F7: Optimized Defaults

Suspend Mode (Disabled)

After the selected period of system inactivity, all devices except the CPU shut off.

Video Off Option (Susp, Stby --> Off)

This option defines if the video is powered down when the system is put into suspend mode.

Video Off Method (DPMS Supported)

This item defines how the video is powered down to save power. This item is set to DPMS (Display Power Management Software) by default.

MODEM Use IRQ (3)

If you want an incoming call on a modem to automatically resume the system from a power-saving mode, use this item to specify the interrupt request line (IRQ) that is used by the modem. You might have to connect the fax/modem

to the motherboard Wake On Modem connector for this feature to work.

HDD Off After (Disable)

The IDE hard drive will spin down if it is not accessed within a specified length of time. Options are from 1 Min to 15 Min and Disable.

Power Button Override (Instant Off)

Under ACPI (Advanced Configuration and Power management Interface) you can create a software power down. In a software power down, the system can be resume by Wake Up Alarms. This item lets you install a software power down that is controlled by the power button on your system. If the item is set to Instant-Off, then the power button causes a software power down. If the item is set to Delay 4 Sec. then you have to hold the power button down for four seconds to cause a software power down.

Power on After Power Fail (Always Off)

This item enables your computer to automatically restart or return to its last operating status after power returns from a power failure.

► PM Wake Up Events

This item opens a submenu that enables you to set events that will resume the system from a power saving mode.

Scroll to this item and press <Enter> to view the following screen:

```
Phoenix - AwardBIOS CMOS Setup Utility
PM Wake Up Events

IRQ [3-7,9-15],NMI      [Enabled]
IRQ 8 Break Suspend    [Disabled]
Resume By Ring          [Disabled]
MACPME Power Up Control [Disabled]
Resume By PCI PME       [Enabled]
Power Up by Alarm       [Disabled]
x Month Alarm           NA
x Day of Month Alarm    0
x Time (hh:mm:ss) Alarm 0 : 0 : 0

** Reload Global Timer Events **
Primary IDE             [Disabled]
Secondary IDE           [Disabled]
FDD,COM,LPT Port       [Disabled]
PCI PIRQ[A-D]#         [Disabled]

Item Help
Menu Level  >>

↑↓←→:Move  Enter:Select  +/-/PU/PD:Value  F10:Save  ESC:Exit  F1:General Help
F5: Previous Values  F6: Fail-Safe Defaults  F7: Optimized Defaults
```

IRQ [3-7, 9-15], NMI (Enabled)

This option determines whether any activity for IRQ 3-7/9-15 will cause the system to wake from a power saving mode.

IRQ 8 Break Suspend (Disabled)

Determines whether the system will monitor IRQ 8 activity and wake the system from a power saving mode when IRQ 8 is activated.

Resume By Ring (Disabled)

An input signal on the serial Ring Indicator (RI) line (in other words, an incoming call on the modem) awakens the system from a soft off state.

MACPME Power Up Control (Disabled)

Use this item to enable MAC activity to wakeup the system from a power saving mode.

Resume By PCI PME (Enabled)

This item specifies whether the system will be awakened from power saving modes when activity or input signal of the specified hardware peripheral or component is detected.

Power Up by Alarm (Disabled)

When set to Enabled, the following three fields become available: Month Alarm, Day of Month, and Time Alarm Upon arrival of the alarm time, it will instruct the system to wake up.

When set to 0 (zero) for the day of the month, the alarm will power on your system every day at the specified time.

****Reload Global Timer Events****

These fields determine which events waken the system from power saving mode.

Primary/Secondary IDE (Disabled)

When this item is enabled, the system power will resume the system from a power saving mode if there is any activity on primary or secondary IDE channels 0 and 1.

FDD, COM, LPT Port (Disabled)

When this item is enabled, the system will restart the power-saving timeout counters when any activity is detected on the floppy disk drive, serial ports, or the parallel port.

PCI PIRQ [A-D]# (Disabled)

When this item is enabled, any activity from one of the listed devices wakes up the system.

Press <Esc> to return to the Power Management Setup screen.

PNP/PCI Configurations

This section describes configuring the PCI bus system. PCI (Peripheral Component Interconnect) is a system, which allows I/O devices to operate at speeds nearing CPU's when they communicate with own special components.

All the options describes in this section are important and technical and it is strongly recommended that only experienced users should make any changes to the default settings.

Phoenix - AwardBIOS CMOS Setup Utility PnP/PCI Configurations		Item Help
Reset Configuration Data	[Disabled]	Menu Level ▶ Default is Disabled. Select Enabled to reset Extended System Configuration Data (ESCD) when you exit Setup if you have installed a new add-on and the system reconfiguration has caused such a serious conflict that the OS cannot boot
Resources Controlled By x IRQ Resources	[Auto(ESCD)] Press Enter	
PCI/VGA Palette Snoop	[Disabled]	
↑↓←→: Move Enter: Select +/-/PU/PD: Value F10: Save ESC: Exit F1: General Help F5: Previous Values F6: Fail-Safe Defaults F7: Optimized Defaults		

Reset Configuration Data (Disabled)

If you enable this item and restart the system, any Plug and Play configuration data stored in the BIOS setup is cleared from memory. New updated data is created.

Resources Controlled By (Auto(ESCD))

You should leave this item at the default Auto(ESCD). Under this setting, the system dynamically allocates resources to Plug and Play devices as they are required. If you select the "Manual" option, the prompt on the following line, "IRQ Resources" will become available to you.

You should leave this item at the default Auto(ESCD). Under this setting, the system dynamically allocates resources to Plug and Play devices as they are required.

If you cannot get a legacy ISA (Industry Standard Architecture) expansion card to work properly, you might be able to solve the problem by changing this item to Manual, and then opening up the IRQ Resources submenu.

▶ IRQ Resources

The submenu allows you to individually assign an interrupt type for interrupts IRQ-3 to IRQ-15.

PCI/VGA Palette Snoop (Disabled)

This item is designed to overcome problems that can be caused by some non-standard VGA cards. This board includes a built-in VGA system that does not require palette snooping so you must leave this item disabled.

PC Health Status

On motherboards that support hardware monitoring, this item lets you monitor the parameters for critical voltages, critical temperatures, and fan speeds.

Phoenix - AwardBIOS CMOS Setup Utility	
PC Health Status	
Shutdown Temperature	[Disabled]
Item Help	
CPU Ucore Voltage	
Memory Voltage	Menu Level →
CPU Temperature	
CPU Fan Speed	
CAS Fan Speed	

↑↓←→:Move Enter:Select +/-/PU/PD:Value F10:Save ESC:Exit F1:General Help
F5: Previous Values F6: Fail-Safe Defaults F7: Optimized Defaults

Shutdown Temperature (Disabled)

Enables you to set the maximum temperature the system can reach before powering down.

System Component Characteristics

These fields provide you with information about the systems current operating status. You cannot make changes to these fields.

Frequency/Voltage Control

This item enables you to set the clock speed and system bus for your system. The clock speed and system bus are determined by the kind of processor you have installed in your system.

Phoenix - AwardBIOS CMOS Setup Utility	
Frequency/Voltage Control	
Auto Detect DIMM/PCI Clk	[Enabled]
Spread Spectrum	[Enable]
CPU Frequency	[100]
CPU:DRAM Frequency Ratio	[Auto]
DRAM Frequency	
	Item Help
	Menu Level ▶

↑|←:Move Enter:Select +/-/PU/PD:Value F10:Save ESC:Exit F1:General Help
F5: Previous Values F6: Fail-Safe Defaults F7: Optimized Defaults

Auto Detect DIMM/PCI Clk (Enabled)

When this item is enabled, BIOS will disable the clock signal of free DIMM and PCI slots.

Spread Spectrum (Enabled)

If you enable spread spectrum, it can significantly reduce the EMI (Electro-Magnetic Interference) generated by the system.

CPU Frequency (100)

This item allows you to set the CPU frequency.

CPU: DRAM Frequency Ratio (Auto)

This item controls the ratio of the CPU FSB clock and DRAM Frequency to enable the CPU and DRAM to run at different frequency combination.

Load Fail-Safe Defaults Option

This option opens a dialog box that lets you install fail-safe defaults for all appropriate items in the Setup Utility:

Press <Y> and then <Enter> to install the defaults. Press <N> and then <Enter> to not install the defaults. The fail-safe defaults place no great demands on the system and are generally stable. If your system is not functioning correctly, try installing the fail-safe defaults as a first step in getting your system working properly again. If you only want to install fail-safe defaults for a specific option, select and display that option, and then press <F6>.

Load Optimized Defaults Option

This option opens a dialog box that lets you install optimized defaults for all appropriate items in the Setup Utility. Press <Y> and then <Enter> to install the defaults. Press <N> and then <Enter> to not install the defaults. The optimized defaults place demands on the system that may be greater than the performance level of the components, such as the CPU and the memory. You can cause fatal errors or instability if you install the optimized defaults when your hardware does not support them. If you only want to install setup defaults for a specific option, select and display that option, and then press <F7>.

Set Supervisor/User Password

When this function is selected, the following message appears at the center of the screen to assist you in creating a password.

ENTER PASSWORD

Type the password, up to eight characters, and press <Enter>. The password typed now will clear any previously entered password from CMOS memory. You will be asked to confirm the password. Type the password again and press <Enter>. You may also press <Esc> to abort the selection.

To disable password, just press <Enter> when you are prompted to enter password. A message will confirm the password being disabled. Once the password is disabled, the system will boot and you can enter BIOS Setup freely.

PASSWORD DISABLED

If you have selected **System** in "Security Option" of "BIOS Features Setup" menu, you will be prompted for the password every time the system reboots or any time you try to enter BIOS Setup.

If you have selected **Setup** at "Security Option" from "BIOS Features Setup" menu, you will be prompted for the password only when you enter BIOS Setup.

Supervisor Password has higher priority than User Password. You can use Supervisor Password when booting the system or entering BIOS Setup to modify all settings. Also you can use User Password when booting the system or entering BIOS Setup but can not modify any setting if Supervisor Password is enabled.

Save & Exit Setup Option

Highlight this item and press <Enter> to save the changes that you have made in the Setup Utility and exit the Setup Utility. When the Save and Exit dialog box appears, press <Y> to save and exit, or press <N> to return to the main menu:

Exit Without Saving

Highlight this item and press <Enter> to discard any changes that you have made in the Setup Utility and exit the Setup Utility. When the Exit Without Saving dialog box appears, press <Y> to discard changes and exit, or press <N> to return to the main menu.

Note: If you have made settings that you do not want to save, use the "Exit Without Saving" item and press <Y> to discard any changes you have made.

This concludes Chapter 3. Refer to the next chapter for information on the software supplied with the motherboard.

Using the Motherboard Software

About the Software CD-ROM

The support software CD-ROM that is included in the motherboard package contains all the drivers and utility programs needed to properly run the bundled products. Below you can find a brief description of each software program, and the location for your motherboard version. More information on some programs is available in a README file, located in the same directory as the software.

Note: Never try to install software from a folder that is not specified for use with your motherboard.

Before installing any software, always inspect the folder for files named README.TXT, INSTALL.TXT, or something similar. These files may contain important information that is not included in this manual.

Auto-installing under Windows 98/ME/2000/XP

The Auto-install CD-ROM makes it easy for you to install the drivers and software for your motherboard.

Note: If the Auto-install CD-ROM does not work on your system, you can still install drivers through the file manager for your OS (for example, Windows Explorer). Refer to Utility Folder Installation Notes later in this chapter.

The support software CD-ROM disc loads automatically under Windows 98/ME/2000/XP. When you insert the CD-ROM disc in the CD-ROM drive, the autorun feature will automatically bring up the install screen. The screen has three buttons on it, Setup, Browse CD and Exit.

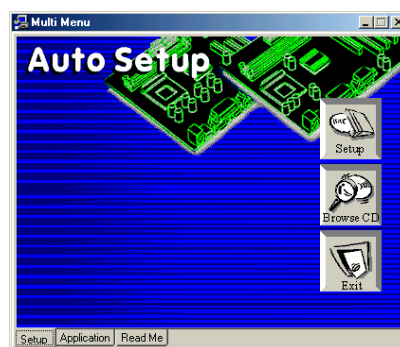

Note: If the opening screen doesn't appear, double-click the file "setup.exe" in the root directory.

Setup Tab

Setup	Click the Setup button to run the software installation program. Select from the menu which software you want to install.
Browse CD	<p>The Browse CD button is the standard Windows command that allows you to open Windows Explorer and show the contents of the support CD.</p> <p>Before installing the software from Windows Explorer, look for a file named README.TXT, INSTALL.TXT or something similar. This file may contain important information to help you install the software correctly.</p> <p>Some software is installed in separate folders for different operating systems, such as DOS, WIN NT, or WIN98/95. Always go to the correct folder for the kind of OS you are using.</p> <p>To install the software, execute a file named SETUP.EXE or INSTALL.EXE by double-clicking the file and then following the instructions on the screen.</p>
Exit	The Exit button closes the Auto Setup window.

Application Tab

Lists the software utilities that are available on the CD.

Read Me Tab

Displays the path for all software and drivers available on the CD.

Running Setup

Follow these instructions to install device drivers and software for the motherboard:

1. Click **Setup**. The installation program begins:

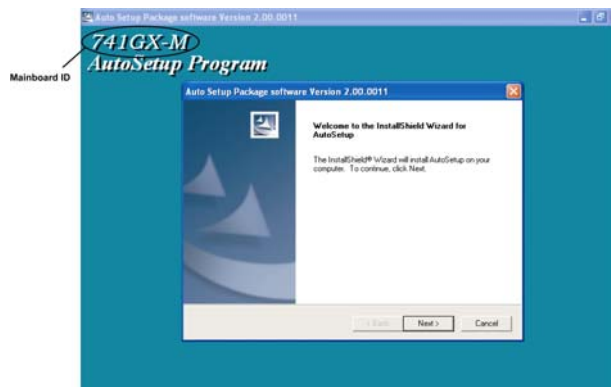

Note: The following screens are examples only. The screens and driver lists will be different according to the motherboard you are installing.

The motherboard identification is located in the upper left-hand corner.

2. Click **Next**. The following screen appears:

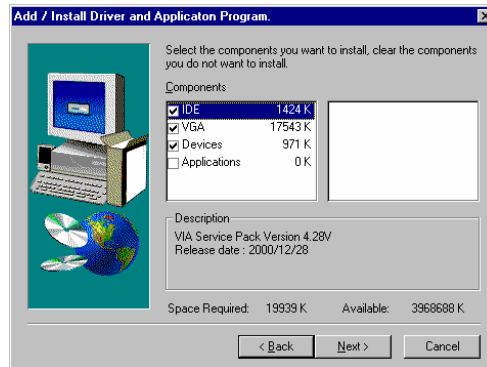

3. Check the box next to the items you want to install. The default options are recommended.
4. Click **Next** run the Installation Wizard. An item installation screen appears:



5. Follow the instructions on the screen to install the items.

Drivers and software are automatically installed in sequence. Follow the on-screen instructions, confirm commands and allow the computer to restart a few times to complete the installation.

Manual Installation

Insert the CD in the CD-ROM drive and locate the PATH.DOC file in the root directory. This file contains the information needed to locate the drivers for your motherboard.

Look for the chipset and motherboard model; then browse to the directory and path to begin installing the drivers. Most drivers have a setup program (SETUP.EXE) that automatically detects your operating system before installation. Other drivers have the setup program located in the operating system subfolder.

If the driver you want to install does not have a setup program, browse to the operating system subfolder and locate the readme text file (README.TXT or README.DOC) for information on installing the driver or software for your operating system.

Utility Software Reference

All the utility software available from this page is Windows compliant. They are provided only for the convenience of the customer. The following software is furnished under license and may only be used or copied in accordance with the terms of the license.

Note: These software(s) are subject to change at anytime without prior notice.
Please refer to the support CD for available software.

AWARD Flash Memory Utility

This utility lets you erase the system BIOS stored on a Flash Memory chip on the motherboard, and lets you copy an updated version of the BIOS to the chip. Proceed with caution when using this program. If you erase the current BIOS and fail to write a new BIOS, or write a new BIOS that is incorrect, your system will malfunction. Refer to Chapter 3, *Using BIOS* for more information.

WinFlash Utility

The Award WinFlash utility is a Windows version of the DOS Award BIOS flash writer utility. The utility enables you to flash the system BIOS stored on a Flash Memory chip on the motherboard while in a Windows environment. This utility is currently available for WINXP\ME\2000\98SE. To install the WinFlash utility, run WINFLASH.EXE from the following directory:

UTILITY\WINFLASH 1.51

PC-CILLIN

The PC-CILLIN software program provides anti-virus protection for your system. This program is available for Windows 2000/ME/98SE/XP and Windows NT. Be sure to check the readme.txt and install the appropriate anti-virus software for your operating system. We strongly recommend users to install this free anti-virus software to help protect your system against viruses.

This concludes Chapter 4.