

Chapter 1

Introduction

1-1 Product Specifications

❑ Processor

- Supports up to 450 MHz Intel **Pentium® II** processors and **Celeron** processors with MMX technology
- Slot 1 CPU socket with folding retention mechanism
- High efficiency **Switching Power Module** (1.8v ~ 3.5v, 0.1v increments)
- Supports 66/100 MHz system clock speeds
- Innovative **SeePU** technology (software CPU installation with no jumper settings)



Supports 75/83/103/112/124/133 MHz system clock speeds for over-clocking possibility. Refer to Section 2-3 for overclocking details.

❑ Chipset

- Intel **82440BX** two chip AGPset

❑ DRAM Memory

- Three 3.3V 168-pin DIMM sockets support up to 384 MB
- Supports 16/32/64/128MB, 64/72-bit unbuffered Synchronous DIMM modules
- Provides single-bit ECC capability



10ns or faster SDRAM DIMM modules with SPD are required for 100MHz frequency clock speed



Because 256MB unbuffered DIMM and Registered DIMM modules are not yet mainstream, their compatibility can not be guaranteed. (See Section 2-5 for details.)

❑ Expansion Slots

- Three 32-bit PCI slots (Rev 2.1 compliant)
- One 16-bit ISA slots (one PCI/ISA shared slot)

❑ BIOS

- Award System BIOS, supports PnP, APM, DMI & Multi-device booting features i.e. floppy, LS120, CD-ROM, HDD(IDE, SCSI), ZIP-ATAPI etc.
- Includes Trend **ChipAway Virus** protection for virus-free boot and virus free operating system

- ✎ The Trend ChipAway Virus is a rule-based anti-virus technology and does not require periodical updates of virus code

❑ **Two Ultra DMA-33 PCI IDE Ports**

- Supports up to PIO Mode 4, Multi-word Mode 2 and Ultra DMA-33 timings
- Bus Mastering software drivers for all well known multi-tasking operating systems

❑ **On-board Ultra I/O**

- ITE 8671 I/O chip
- One Parallel (SPP/ECP/EPP) and two Serial (16550A compliant) ports
- One floppy disk drive connector supports up to 2.88MB, Japanese 3-Mode, and 1Mbps transfer rates
- IrDA IR function supports up to 115.2Kbps

❑ **Double Stack Back-Panel I/O Connector**

- PS/2 Mini-DIN keyboard and mouse port
- Two USB ports
- One 15-pin D-Sub female VGA port
- One 9-pin D-Sub male Serial port
- One 25-pin D-Sub female Printer port
- Audio Line-in/out and Mic-in jacks
- One 15-pin D-Sub female Game/MIDI port

❑ **On-board Audio Chip**

- ESS **Maestro-2** audio chip
- Built-in original Microsoft **Direct Sound** and **Direct Sound 3D** acceleration
- **Advanced Wavetable Synthesizer** using wavedata on system memory.
- Legacy audio compatible
- Supports all games in **Aureal 3D API**

❑ **On-board 3D AGP VGA**

- **ATI Rage Pro AGP** chip for workstation class graphic performance
- **4MB SGRAM** onboard

❑ **Two Channel USB Ports**



Now under compatibility testing with different peripherals

❑ **Board Dimensions**

- Micro ATX form factor, 244mm x 230mm, 4 Layers
- Six mounting holes

❑ Advanced Management Features

- Software power off control, Power-on by modem, Power on by alarm, Power-on by keyboard, Over-ride power button, Power failure recovery, Blinking LED in Suspend, Power on by mouse, Power on safe guard, **Wake Up On LAN**, etc.
- **Poly-fuse** over-current protection for USB and keyboard
- Flash BIOS protect via BIOS
- Supports **SB-link** header for Creative PCI audio cards
- Optional on-board Management Extension Hardware includes system monitoring software to streamline PC management
- Meets EPA Green PC standard: power consumption under 30W in Doze, Standby, CPU fan off and Suspend modes
- **ACPI** features ready when ACPI-enabled O/S is available

❑ Switching Power Supply Requirement (at least 200 Watts)

Output Voltage	Max. Regulation Requirement	Min. Current Requirement (Amps)
+12V	+/- 5%	0
+5V	+/- 5%	1
+3.3V	+/- 5%	10*
-5V	+/- 10%	0
-12V	+/- 10%	0
+5VSB	+/- 5%	0.75

Table 1-1

- * 3.3V at 10Amps is necessary too guarantee full loading operation because some AGP cards and memory modules have high current consumption.

1-2 Package Contents

This product comes with the following components:

- ❑ One mainboard
- ❑ On-board Slot 1 foldable retention mechanism and four screws
- ❑ One 40-pin IDE connector ribbon cable (Figure 1-1)
- ❑ One 34-pin floppy disk drive ribbon cable (Figure 1-2a) or (Figure 1-2b)
- ❑ One Plastic Stub for standard ATX chassis installation (Figure 1-3)
- ❑ One User's Manual
- ❑ One CD-ROM that includes
 - Acrobat Reader
 - Sound Driver and Utility
 - Graphics Accelerator Driver and Utility
 - Award DMI Utility
 - Award Flash EPROM Utility
 - Intel Bus Master IDE drivers for Win95, WinNT, and OS/2
 - Exclamation Mark Remover Utility
 - System Health Monitoring Software
 - Trend **PC-cillin** Anti-virus v3.0(OEM version) Utility in eight different languages



Figure 1-1

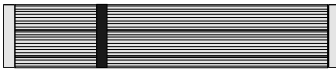

Figure 1-2a Standard Floppy cable



Figure 1-2b Optional 5.25 in. floppy cable

Insert the stub if the mounting screw is not supported by the ATX case

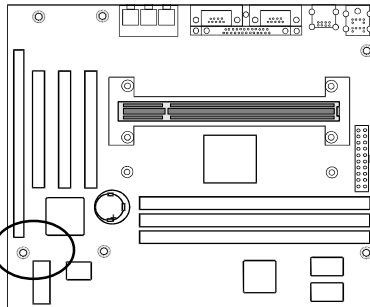
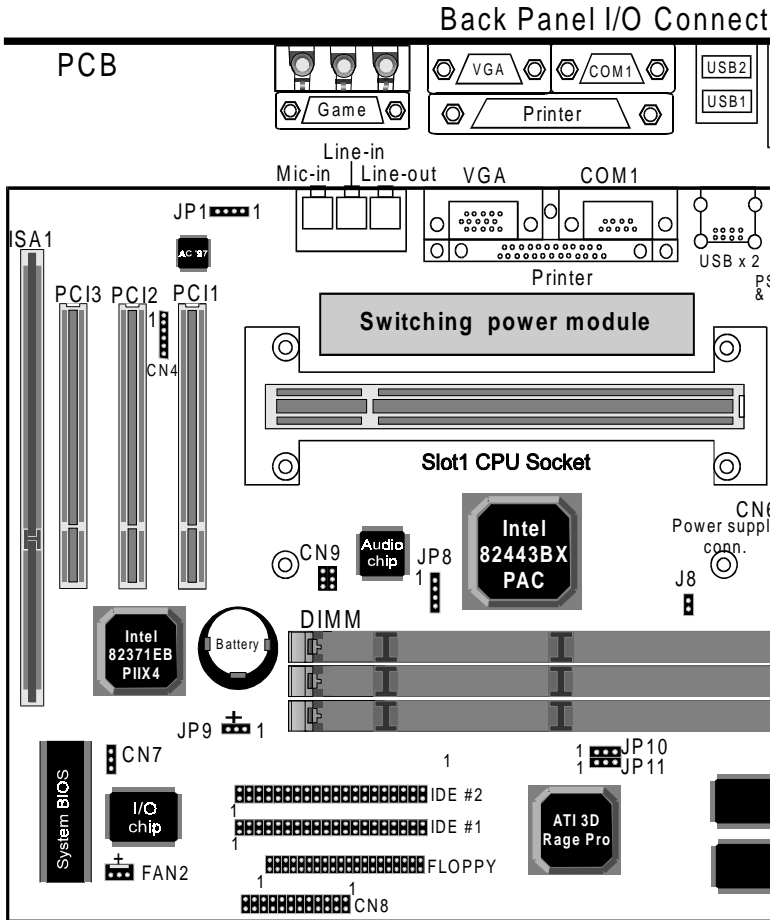

Figure 1-3

1-3 Mainboard Layout



1-4 Connector and Jumper Reference Chart

Jumper & Connector No.	Function	P
CN4	Infrared connector	
CN5	Chassis Intrusion Monitoring connector	
CN7	WOL (Wake on LAN) connector	
CN9	Creative's SB-LINK Sound connector	
CN8	Keyboard lock and power indicator LED connector	
	System reset switch connector	
	Speaker connector	
	IDE Activity LED connector	
	Turbo LED connector	
	Green switch connector	
	Green LED connector	
	Over-ride power button connector	
JP1	CD-ROM Audio-in	
J8	External clock frequency jumper	
JP8	I2S connector for MPEG-in	
JP9	Clear CMOS data jumper	
JP10/JP11	Onboard VGA (Enabled/Disabled) jumper	
FAN 1	CPU cooling fan connector	
FAN 2	System cooling fan connector	
Ports	PS/2 mouse and keyboard ports	
Ports	USB (Universal Serial Bus) ports	

Hardware Setup

If your mainboard has already been installed in your computer you may still need to refer to this chapter if you plan to upgrade your system's hardware.

! Be sure to disconnect the power cable from the power source before performing any work on your mainboard, i. e. installing a CPU, memory module, changing a jumper setting, etc. Not doing so may result in electrical shock!

2-1 Introduction to Jumpers

Jumpers are used to select between various operating modes. A jumper consists of a row of gold colored pins that protrude from the surface of the mainboard. It is important not to confuse jumpers with connectors or headers.

! Putting jumper caps on anything that is not a jumper may result in damaging your mainboard. Please refer to Section 1-3, Mainboard Layout, for the location of jumpers on your mainboard.

As indicated in Figure 2-1 below, a cap is used to cover the pins of a jumper, resulting in shorting those pins that it covers. If the cap is removed from the top of the pins, the jumper is left "open." The number 1 shown both in the diagram below and in all multiple pin jumper and header diagrams in this manual indicates the pin designated with the number 1. The numbering of the remaining pins follows in sequence.

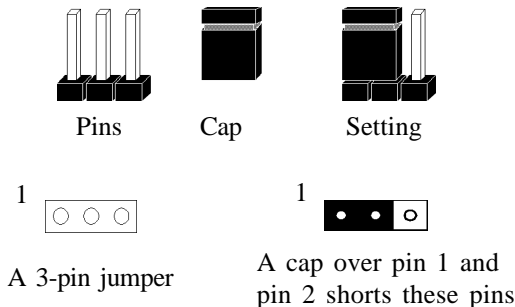

Figure 2-1

2-2 Installing an S.E.C. Processor in Slot 1

1. Insert the Pentium II processor into the retention mechanism. Press evenly and gently until the snaps on the upper side of the processor have been inserted into the holes at the top of the retention mechanism.
2. Note that when removing the processor, these snaps can be clicked into a completely vertical position, leaving your hands free to stabilize the board. Pull the processor evenly and gently out of the retention mechanism.
3. Also note that like PCI and ISA slots, Slot 1 has a divider that prevents backwards insertion of the CPU.



Installing a heat sink and cooling fan is necessary for proper heat dissipation from your CPU. Failing to install these items may result in overheating and possible burn-out of your CPU.

2-3 Setting Your CPU's Parameters(SeePU Technology)

SeePU is a new user friendly technology that enables the user to setup a mainboard's CPU parameters through an easy to use BIOS setup procedure. It is no longer necessary to make many jumper settings as on conventional mainboards.

1. After installing all your hardware into your PC system, turn on your system's power. Enter the CMOS Setup Utility by pressing the Delete key when your BIOS identification screen appears.
2. Move the cursor to SeePU & Chipset Setup menu and press Enter. Find the CPU Setup commands at the right hand part of the BIOS screen (Figure 2-2) Commands for operating the cursor in BIOS are found at the lower right of the BIOS screen.

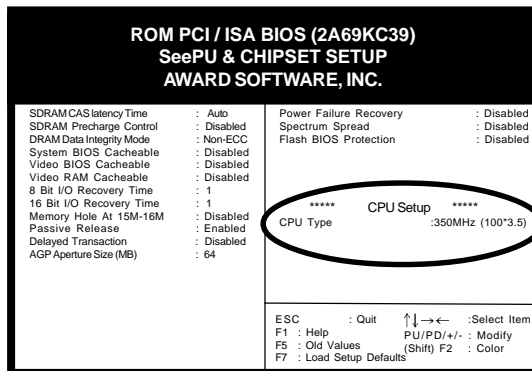

Figure 2-2

3. Change the CPU Type according to the speed of your Pentium II processor. See Figure 2-3 for frequency specifications.

CPU Type	CPU Speed		
	External Clock	Frequency Ratio	Internal Clock
Pentium II processor	66	3.5	233
		4	266
		4.5	300
		5	333
	100	3.5	350
		4	400
		4.5	450
		5	500

Figure 2-3

4. Use the User Define option to customize your CPU's parameters. Set the frequency ratio (also known as external clock multiplier factor) and CPU bus frequency according to your processor's specifications. See Figure 2-4.



You do not need to make voltage settings because *SeePU* automatically sets your CPU voltage.

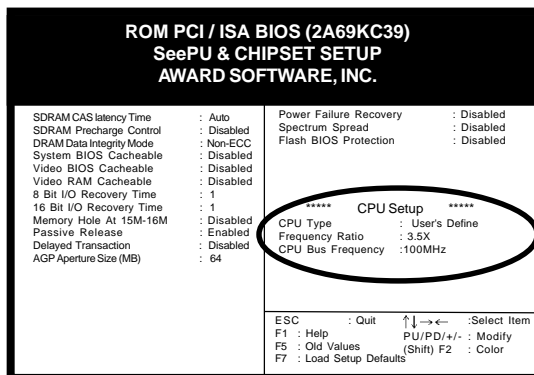

Figure 2-4

5. Press Esc to return to the CMOS Setup Utility, press F10 to Save and Exit Setup and choose 'Y' to confirm. The system will automatically reboot and during startup you will see the correct CPU type displayed on the start-up screen.

Overclocking

Operating a CPU at a higher frequency than it's specification allows is called overclocking. If the CPU frequency is set at a higher frequency than it's specification allows, it may or may not run at that frequency, depending on the quality of your CPU and the extent to which the frequency has been overset. The mainboard manufacturer highly discourages overclocking as it may result in data loss, CPU burn-out, system failure, etc.

External Clock Frequency Jumper (J8)

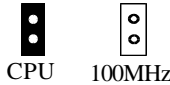
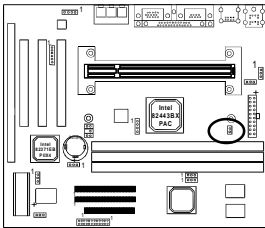

This jumper allows the external clock frequency to be determined either by the CPU or the user. If the pins are shorted the CPU determines the external clock speed and if left open the external clock is always at 100MHz.

Many Pentium II processors are frequency locked processors and are not able to perform overclocking. Regardless of whether the processor is a frequency locked, overclocking may cause some processors to hang when turning on the system. When the processor hangs, the screen remains blank and the system does not boot. To solve this problem, do the following.

1. Turn off the computer and then press the Home key on your keyboard
2. Turn on your computer, wait for five seconds and then release the Home key. (Pressing the Home key allows the computer to boot at a low system speed. For example, for 66MHz external clock CPUs, the CPU boot-up speed is 233MHz. For 100MHz external clock CPUs, the CPU boot-up speed is 350MHz.)
3. Enter BIOS Setup and reconfigure your CPU parameters as described in this section

2-4 Connector and Jumper Settings

Connectors are used to link the system board with other parts of the system, including the power supply, the keyboard, and the various controllers on the front panel of the system case.



The power supply connector is the last connection to be made while installing a mainboard. Before connecting the power supply, please make sure it is not connected to the power source.

ATX Power Supply Connector

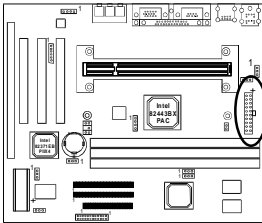

This mainboard requires a power supply of at least 200 watts. The power cord leading from the system's power supply to the external power source must be the very last part connected when assembling a system.

12V	⑩	⑳	5V
5VSB	⑨	⑲	5V
PW-OK	⑧	⑱	-5V
Ground	⑦	⑰	Ground
5V	⑥	⑱	Ground
Ground	⑤	⑱	Ground
5V	④	⑱	PS-ON
Ground	③	⑱	Ground
3.3V	②	⑱	-12V
3.3V	①	⑱	3.3V

The ATX power supply provides a single 20-pin connector interface which incorporates standard +/-5V, +/-12V, optional 3.3V and Soft-power signals. The Soft-power signal, a 5V trickle supply is continuously supplied when AC power is available. When the system is in the Soft-Off mode, this trickle supply maintains the system in it's minimum power state.

Software Power-Off Control

This mainboard can be powered down using the Windows 95 Software Power-Off function. To power down your computer, click the START button on the Windows 95 task bar. Select "Shut Down The Computer" and the system turns off. The message "It is now safe to turn off your computer" will not be shown when using this function.

Power-On By Modem

While in Soft-off state, if an external modem ring-up signal occurs, the system wakes up and can be remotely accessed. Enable this function in BIOS's Power Management Setup menu. (See section 3-4)

Front Panel Connector Set (CN8) A through G

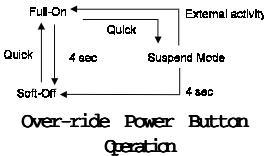
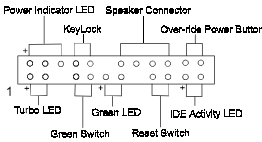
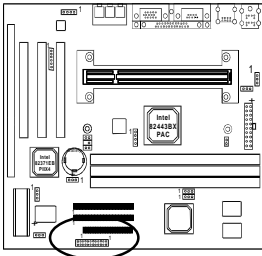

A. Over-ride Power Button Connector

The power button on the ATX chassis can be used as a normal power switch as well as a button to activate Advanced Power Management Suspend mode. This mode is used for saving electricity when the computer is not in use for long periods of time. The Soft-OFF by PWR-BTTN function in BIOS's Power Management Setup menu must be set to "Delay 4 Sec." to activate this function. (See section 3-4)

When the Soft-OFF by PWR-BTTN function is enabled, pushing the power button rapidly will switch the system to Suspend mode. Any occurrence of external activity such as pressing a key on the keyboard or moving the mouse will bring the system back to Full-On. Pushing the button while in Full-On mode for more than 4 seconds will switch the system completely off. See Over-ride Power Button Operation diagram.

B. Keyboard Lock & Power Indicator LED Connector

Plugging this connector into the lock on the front panel of the system case allows the lock to enable or disable the keyboard. This function provides limited security against casual intruders. The power indicator LED shows the system's power status. It is important to pay attention to the correct cable and pin orientation (i.e., not to reverse the order of these two connectors.)

	Pin	Definition
Power Good LED	1	+5V DC
	2	No Connect
	3	Ground
Keyboard Lock	4	Keylock
	5	Ground

Blinking LED in Suspend Mode

While in Suspend mode, the LED light on the front panel of your computer will flash. Suspend mode is entered by pressing the Override Power Button, pushing the Green button on your ATX case, or enabling the Power Management and Suspend Mode options in BIOS's Power Management menu. (See section 3-4)

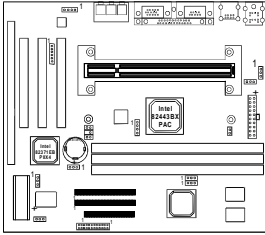

C. Green Switch/Green LED Connector

Some ATX cases provide a Green switch which is used to put the system in Suspend mode. In Suspend mode, the power supply to the system is reduced to a trickle, the CPU clock is stopped, and the CPU core is in its minimum power state. The system is woken up whenever the keyboard or mouse is touched. The system resumes in different ways as defined by Power Management Setup screen in BIOS.

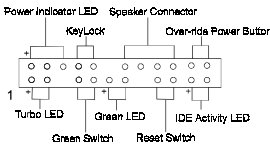

D. System Reset Switch Connector

This connector should be connected to the reset switch on the front panel of the system case. The reset switch allows you to restart the system without turning the power off.

Pin	Definition
1	System
2	GND

E. Speaker Connector

PIN	Definition
1	Speaker Signal
2	NC
3	NC
4	+5V DC

F. IDE Activity LED Connector

The IDE activity LED lights up whenever the system reads/writes to the IDE devices.

G. Turbo LED Connector

This mainboard does not have a Turbo/De-turbo speed modes. Even though this function does not exist, the turbo LED will light when the LED is connected and turbo button pressed.

Creative's SB-LINK Sound Connector (CN9)

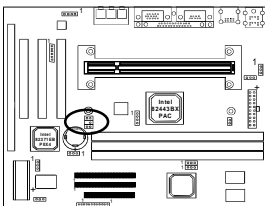

The SB-LINK serves as a bridge between the mainboard and Creative's PCI sound card. This connector delivers Sound Blaster 16 compatibility for real-mode DOS games.

Infrared Connector (CN4)

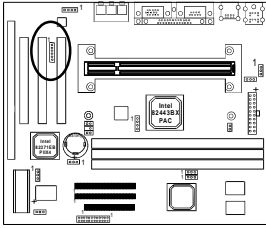

If you enable the COM2 Mode in BIOS's Integrated Peripherals menu, the COM2 port will support IR functions. (See section 3-7)

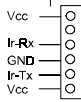

CPU/System Cooling Fan Connectors (FAN1/FAN2)

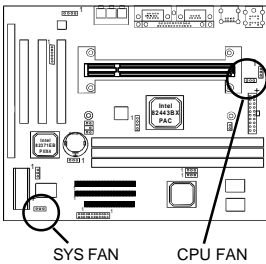

These added connectors allow the fan to draw their power from the mainboard instead of the disk drive connector. The board's management extension hardware is able to detect the CPU and system fan speed in rpm (revolutions per minute). These connectors supports 3-pin cooling fans with minimum of 3500 RPM. The wiring and plug may vary depending on the manufacturer. On standard fans, the red is positive (+12V), the black is ground, and the yellow wire is the rotation signal.



WOL (Wake-on-LAN) Connector (CN7)

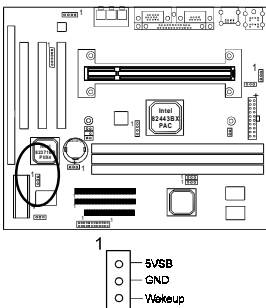

Enable the Wake Up On LAN selection in BIOS's Power Management Menu to use this function. The capability to remotely manage PCs on a network is a significant factor in reducing administrative and ownership costs. Magic Packet technology is designed to give WOL (Wake-on-LAN) capability to the LAN controller. When a PC capable of receiving wake up command goes to sleep, the Magic Packet mode in the LAN controller is enabled. When the LAN controller receives a Magic Packet frame, the LAN controller will wake up the PC. This header is used to connect an add-in NIC (Network Interface Card) which gives WOL capability to the mainboard.



To support this function, a switching power supply with a minimum of **750mA 5VSB** is required.

Clear CMOS Data Jumper (JP9)

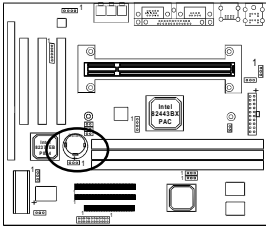

- 1 Normal (default) 1 Clear CMOS data

To clear the contents of the CMOS, please follow the steps below.

1. Disconnect the system power supply from the power source.
2. Set the jumper cap at location 2~3 for 5 seconds, then set it back to the default position.
3. Connect the system's power and then start the system.
4. Enter BIOS's CMOS Setup Utility and choose Load Setup Defaults. Type Y and press enter.
5. Set the system configuration in the Standard CMOS Setup menu.

PS/2 Mouse and Keyboard Ports

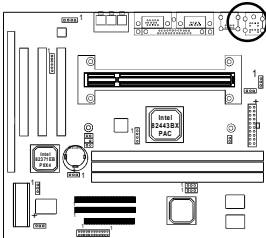

If a PS/2 mouse is used, BIOS will automatically detect and assign IRQ12 to the PS/2 mouse.



Pin	Definition
1	Data
2	No Connect
3	Ground
4	+5V (fused)
5	Clock
6	No Connect

Poly-fuse Over Current Protection

The poly-fuse protects the system from dangerous voltages the system might be exposed to via the keyboard or USB connectors. In case of such exposure, the poly-fuse will immediately be disconnected from the circuit, just like a normal fuse. After being disconnected for a certain period of time, the poly-fuse will return to its normal state, after which the keyboard or USB can function properly. Unlike conventional fuses, the poly-fuse does not have to be replaced, relieving the user wasted time and inconvenience.

CD-ROM Audio-in (JP1)

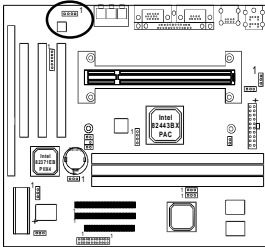

Use the cable enclosed with your CD-ROM disk drive to connect the CD-ROM to your mainboard. This will enable your CD-ROM's audio function.



I²S Connector For MPEG-in (JP8)

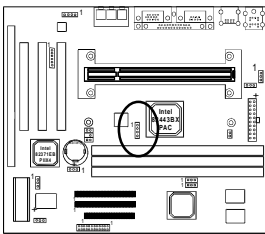

The I²S Connector supports the MPEG sound decoder. This connector must be connected to the cable from the MPEG card.

Onboard VGA (Enabled/Disabled) Jumper (JP10/JP11)

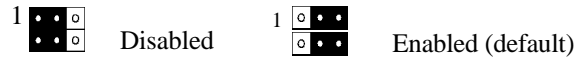
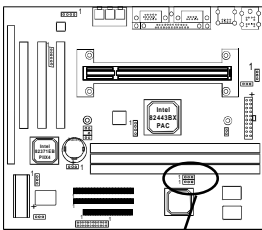

Put the jumper cap on pin 2-3 to enable onboard VGA function and on pins 1-2 to disable this function.

Chassis Intrusion Monitoring Connector (CN5)

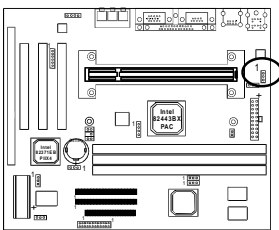

If the W83781D chip is next to the slot 1, this mainboard will support the chassis instruction monitoring feature. A mechanical or photo sensor switch is attached to the motherboard through this 1x3-pin chassis security header. The mechanical switch is set to open to disable this function.



USB(Universal Serial Bus) Ports

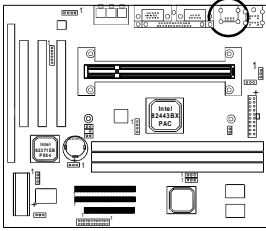

If you want to use a USB keyboard, you must enable the USB keyboard support function in BIOS's Integrated Peripherals menu (See Section 3-7). USB is an open industry standard, providing a simple and inexpensive way to connect up to 125 devices to a single computer port. Keyboards, mice, tablets, digitizers, scanners, bar-code readers, modems, printers and many more can all be used at the same time.

USB is a dynamically reconfigurable serial bus with an elementary data rate of 12Mbps. Based on off the shelf, low cost micro-controller technology, its modular layered software protocol supports sophisticated devices and application programs.

This board contains a USB Host controller and includes a root hub with two USB ports (meets USB Rev 1.0 spec.). Two USB peripherals or hub devices are able to be connected.



Compatibility with different USB peripherals is still being tested.

2-5 Main Memory Configuration

The DRAM memory system consists of three banks and the memory size ranges from **16~384 MBytes**. It does not matter which bank you want to install first.

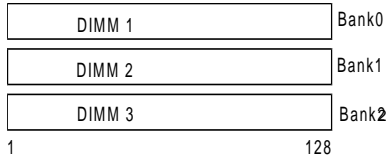

DRAM Specifications

	System Frequency	SDRAM Type	Max Memo
3 unbuffered DIMM Modules	66MHz	12ns or faster	384MB
	100MHz	10ns or faster	
3 Registered DIMM Modules	66MHz	12ns or faster	768MB
	100MHz	10ns or faster	

DIMM type 3.3V, unbuffered, registered, 64/72-bit SDRAM with SPD*

Module size: Single/double-side 16/32/64/128 MBytes

Parity: Either parity or non-parity

 The compatibility with 256MB and Registered DIMM is still under testing and cannot be guaranteed.

 This mainboard supports 3.3v, unbuffered, 4-clock, SDRAM DIMM only. Buffered, 5V, or 2-clock SDRAM DIMMs should not be used.

 Due to loading anomalies, using DIMM with an 'n x 4' DRAM base on this mainboard is not recommended. For example, a DIMM that uses sixteen 16Mb x 4 devices should not be used.

SPD (Serial Presence Detect)

This is an EPROM that contains speed and design information about the memory module. The mainboard queries the module and makes adjustments to system operation based on what it finds.

ECC DRAM Capability

This mainboard can be configured to support ECC (Error Check and Correct) function when utilizing parity DIMM modules. To utilize the chipset's ECC features, you must use a 72-bit DIMM module. These modules are automatically detected during bootup. However, the user must configure the DRAM Data Integrity Mode to "ECC" in BIOS's Chipset Features Setup menu to enable this function. ECC detects double bit errors and detects and corrects single bit memory errors on the fly without user intervention. Errors may be generated by a defective memory module, conflicting memory speeds between different banks, DMA, etc.



Memo

Award BIOS Setup Program

Award's BIOS ROM has a built-in setup program that allows users to modify the basic system configuration. This information is stored in CMOS RAM so that it can retain the setup information, even when the power is turned off.

When you turn on or reboot the system, press the Delete key to enter the Award BIOS setup program. The primary screen as shown in Figure 3-1 is a list of the menus and functions available in the setup program. Select the desired item and press enter to make changes. Operating commands are located at the bottom of this and all other BIOS screens. When a field is highlighted, on-line help information is displayed on the left bottom edge of the screen.

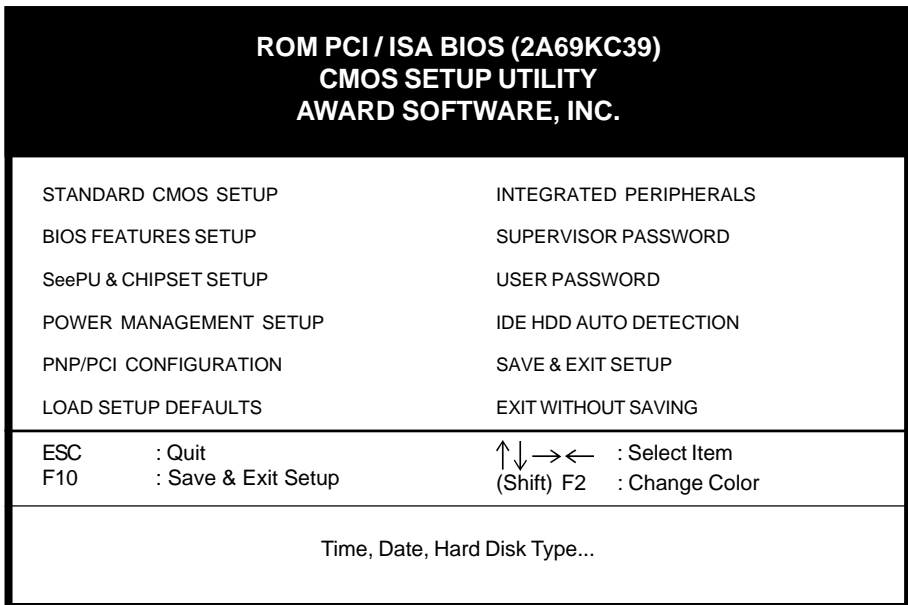

Figure 3-1 Setup Program Initial Screen

3-1 Standard CMOS Setup

The Standard CMOS Setup allows users to configure system components such as hard disk drive, floppy disk drive and video display as well as date, time and boot-up error signaling. This configuration menu should be changed when installing a mainboard for the first time, changing hardware in your system such as the HDD, FDD, video display, or when the CMOS data has been lost or contaminated. Choose the Standard CMOS Setup option from the CMOS Setup Utility menu (Figure 3-1) to display the following screen. When a field is highlighted, on-line help information is displayed on the left bottom edge of the screen.

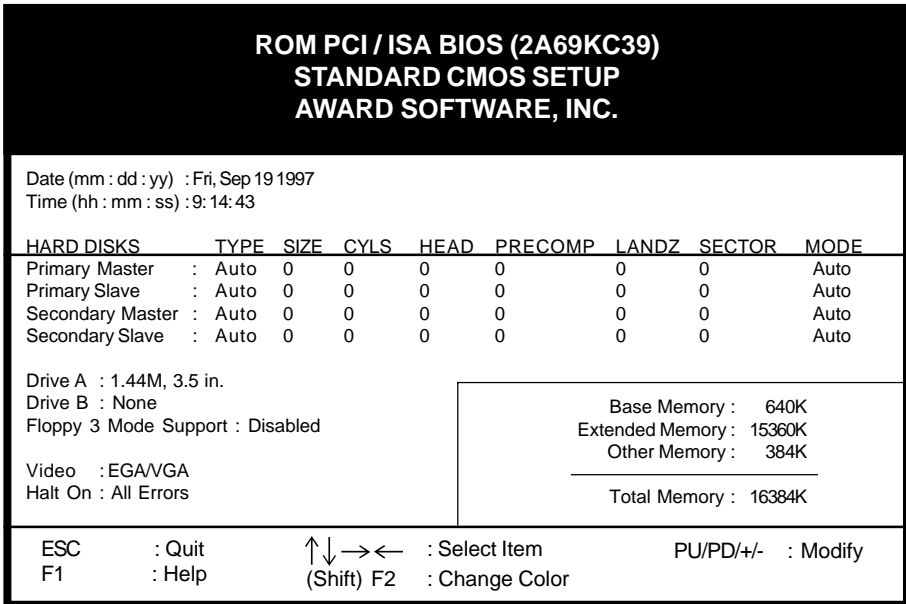

Figure 3-2 Standard CMOS Setup Screen

Date/Time

Set the date and time. Do not skip this function as all of your timed events such as power management, saving files, etc. are based on this timer.

Hard Disk Setup (Primary/Secondary; Master/Slave)

This category identifies up to four IDE hard disk drives that have been installed in the computer. This section does not show information on other IDE devices such as CD-ROM drives or other hard drive types such as SCSI drives.

Type (Auto/User/None): Use the fields under the Type column to determine the method you will use to configure the IDE devices. If you choose Auto, BIOS will automatically detect and make optimal settings for most IDE hard drives.



The mainboard manufacturer recommends that you choose Auto for all drives.

Choose User to define your own drive type manually. You must enter values indicated in the table below into each drive parameter field. This information should be included in the documentation from your hard disk vendor or system manufacturer:

TYPE	Setting method
CYLS	Number of cylinders
HEAD	Number of heads
PRECOMP	Write precompensation cylinder
LANDZ	Landing zone
SECTOR	Number of sectors
MODE	Mode type

Table 3-1 Hard Disk Drive Parameters

Cyls/Head/Sector: The number of Cylinders, Heads, and Sectors can usually be found written on the top of the hard disk. If you have a relatively new hard drive, entering this information alone is usually sufficient for normal hard disk operation. The hard disk will not work properly if you enter improper information for these categories.

Precomp: Older hard drives (i.e., MFM or RLL drives) have the same number of sectors per track at the innermost tracks as at the outermost tracks. Thus, the data density at the innermost tracks is higher and the bits are lying closer together. Even though the physical size of a sector gets progressively smaller as the track diameter diminishes, each sector must still hold 512 bytes. Write precompensation circuitry compensates for the difference in sector size by boosting the write current for inner track sectors.

Landz: This defines the address of the landing zone and is only used for older hard drives which do not have an auto-parking feature.

Mode: If the Type value is not None for any device, you must set the Mode value for that device. There are four different Mode values: Auto, Normal, Large, and LBA.

Auto - BIOS detects and enters the IDE drive type during bootup.

Normal - for IDE drives that meet the old IDE specification which support a maximum capacity of 528MB (1024 cylinders, 16 heads, and 63 sectors).

Large - for IDE drives that do not support LBA and have more than 1024 cylinders. Try this setting if your hard disk does not operate properly with the LBA setting. Large mode is not supported by all operating systems, i.e., only certain versions of DOS support large mode.

LBA - (Large/Logical Block Addressing) With LBA, the IDE controller transforms the data address described by sector, head, and cylinder number into a physical block address, significantly improving data transfer rates. This mode is for drives with greater than 1024 cylinders and between 528MB and 8.4GB in size. This protocol is the current common standard.

Choose None for Type if there are no IDE HDD devices in your system.

- ☞ You can use the IDE HDD Auto Detection function to auto detect your hard drive parameters. Using this function will automatically insert the parameters discussed under Hard Disk Setup and will indicate User for the Field value. Please see Section 3-9 for more information.

Floppy Disk Drives

Choose the memory capacity and disk size that corresponds with that of your floppy disk drive(s).

Video

Select the type of video adapter present in your system. You can ignore this setting if you are using a VGA monitor since VGA BIOS automatically configures this setting.

Halt

When the system is powered on, BIOS performs a series of diagnostic tests called POST (Power On Self Test). This function stops the computer if BIOS detects a hardware error. You can tell BIOS to halt on all errors, no errors, or not to halt on specific errors.

3-2 BIOS Features Setup

By choosing the BIOS Features Setup option from the CMOS Setup Utility menu (Figure 3-1), the screen below is displayed. This sample screen contains the manufacturer's default values for the mainboard.

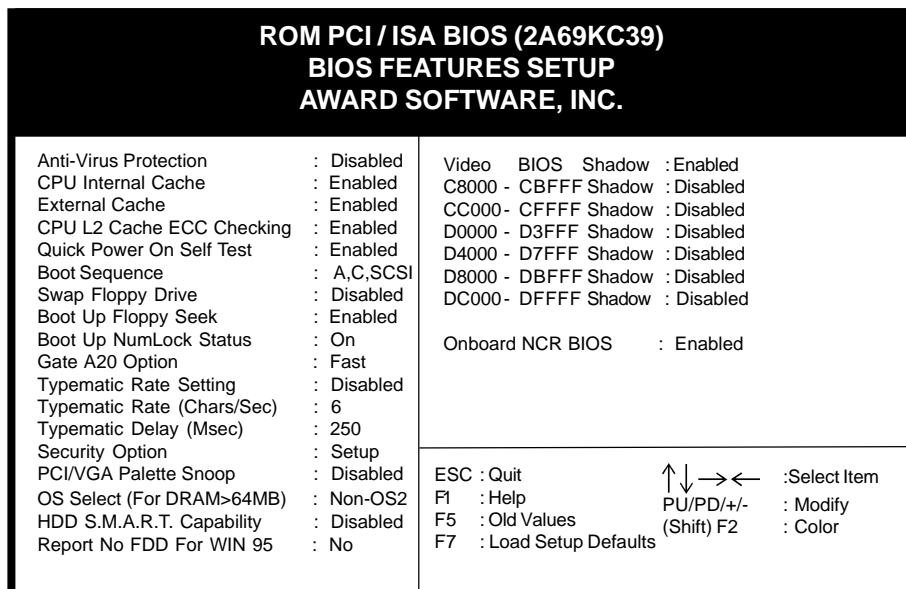

Figure 3-3 BIOS Feature Setup Screen

A. VIRUS PROTECTION

Anti-Virus Protection

This is an anti-virus code incorporated in the mainboard's BIOS firmware. During the boot-up sequence, BIOS loads before loading of the partition table or boot sector. The anti-virus code loads with BIOS and is able to detect boot-up viruses before they have a chance to infect the hard drive. This function employs rule-based logic that doesn't look for specific viruses but rather detects patterns found in every virus, eliminating the need to perform periodical version updates after new viruses have been found.

B. CACHE CONTROL

CPU Internal Cache/External Cache

Cache memory is much faster than conventional DRAM system memory. These fields allow you to enable or disable the CPUs Level 1 built-in cache and Level

2 external cache. Both settings are left enabled to significantly increase the performance of your computer.

CPU L2 Cache ECC Checking

Enable this function to perform ECC (Error Check and Correct) on the CPU's L2 SRAM. ECC detects and corrects single-bit errors while it only detects double bit errors. Certain SDRAM modules also have ECC capability. For more information on SDRAM, see section 2-5. If you are using a 333MHz or higher CPU, this function must be enabled.

C. BOOT UP FEATURES

After turning on the system, BIOS will perform a series of device initializations and diagnostic tests discussed below.

Quick Power On Self Test (POST)

Enable this function to reduce the amount of time required to run the POST (Power On Self Test). BIOS saves time by skipping some items during POST. It is recommended that you disable this setting. Discovering a problem during bootup is better than losing data during your work.

Boot Sequence

This option sets the sequence of drives BIOS attempts to boot from after POST completes. BIOS will search these drives for an operating system.

Swap Floppy Drive

Enabling this function will swap the floppy drive assignment so that drive A will function as drive B, and drive B will function as drive A. Note that the boot sequence assignment mentioned directly above does not include booting from floppy drive B. This function is useful if floppy drives B and A are of a different format and you want to boot from floppy drive B.

Boot up Floppy Seek

During POST, BIOS will determine if the installed floppy disk drive has 40 or 80 tracks. A 360K drive has 40 tracks and 720K, 1.2M and 1.44M drives have 80 tracks. All modern floppy disk drives have 80 tracks.

Boot Up NumLock Status

This function defines the keyboard's numberpad as number keys or arrow keys.

D. Gate A20 Option

Gate A20 refers to the way the system addresses memory above 1 MB (extended memory). When set to Fast, the system chipset controls Gate A20. When set to Normal, a pin in the keyboard controller controls Gate A20. Setting Gate A20 to Fast improves system speed, particularly with OS/2 and Windows.

E. KEYBOARD INTERFACE

Typematic Rate Setting

When enabled, you can set the following two typematic control items. When disabled, keystrokes are determined arbitrarily by the keyboard controller in your system.

Typematic Rate (Chars/Sec)

The typematic rate sets the rate at which characters on the screen repeat when a key is pressed and held down.

Typematic Delay (Msec)

The typematic delay sets how long after you press a key that a character begins repeating.

F. Security Option

The Supervisor and/or User Password functions shown in Figure 3-1 must be set to take advantage of this function. See Section 3-8 for password setting information. When the Security Option is set to System, a password must be entered to boot the system or enter the BIOS setup program. When the Security Option is set to Setup, a password is required to enter the BIOS setup program.

G. PCI/VGA Palette Snoop

Some non-standard VGA cards or MPEG video cards may not show colors properly. Setting this function to Enabled can correct this problem.

H. OS Select (For DRAM > 64MB)

If your system's DRAM is larger than 64MB and you are running OS/2, select OS/2 as the item value. Otherwise, set the item value to Non-OS/2 for all other operating systems.

I. HDD S.M.A.R.T. Capability

S.M.A.R.T. or Self-Monitoring, Analysis, and Reporting Technology enables a drive's internal status to be monitored through diagnostic commands. Both your hard drive must support this capability and this function must be enabled in order to take advantage of this function. See your hard drive literature for more information.

J. Report No FDD For WIN 95

To pass the Windows 95 SCT testing, this item should be enabled.

K. Shadow Memory

Software such as system BIOS, video BIOS, SCSI BIOS, etc that resides in ROM (Read Only Memory) chips is called firmware. Shadowing of firmware occurs when BIOS is copied to RAM address C0000h through DFFFFh. Video BIOS loads into the C0000-C7FFF memory area when video shadowing is enabled. If an expansion peripheral in your system contains ROM-based firmware, you need to know the address range the ROM occupies to shadow it into the correct area of RAM.

Shadowing improves the firmware's performance because the firmware can be read by the CPU through the 16- or 32-bit DRAM bus as opposed to the 8-bit XT bus. However, shadowing also results in reducing the amount of high memory (640 KB to 1 MB) for loading device drivers. Shadowing is used mostly for ROM chips on ISA cards and not for PCI cards. Shadowing and playing games at the same time may result in system instability as some games access the RAM memory area being shadowed.

L. Onboard NCR BIOS

Some NCR cards don't have BIOS onboard. Set this function to Enabled if the card don't have BIOS onboard. Disabled this function if the NCR card is with a BIOS onboard.

3-3 SeePU & Chipset Setup

By choosing the *SeePU* & Chipset Setup option from the CMOS SETUP UTILITY menu (Figure 3-1), the screen below is displayed. This sample screen contains the manufacturer's default values for the mainboard.

ROM PCI / ISA BIOS (2A69K39) SeePU & CHIPSET SETUP AWARD SOFTWARE, INC.			
SDRAM CAS Latency Time	: Auto	Power Failure Recovery	: Disabled
SDRAM Precharge Control	: Disabled	Spectrum Spread	: Disabled
DRAM Data Integrity Mode	: Non-ECC	Flash BIOS Protection	: Disabled
System BIOS Cacheable	: Disabled		
Video BIOS Cacheable	: Disabled		
Video RAM Cacheable	: Disabled		
8 Bit I/O Recovery Time	: 1	***** CPU Setup *****	
16 Bit I/O Recovery Time	: 1	CPU Type	: 350MHz (100*3.5)
Memory Hole At 15M-16M	: Disabled		
Passive Release	: Enabled		
Delayed Transaction	: Disabled		
AGP Aperture Size (MB)	: 64		
		ESC : Quit	↑ ↓ → ← : Select Item
		F1 : Help	PU/PD/+/- : Modify
		F5 : Old Values	(Shift) F2 : Color
		F7 : Load Setup Defaults	

Figure 3-4 Chipset Features Setup Screen



With the exception of the CPU Setup, all of the above settings have been determined by the mainboard manufacturer and should not be changed unless you are absolutely sure of what you are doing. Explanation of the DRAM timing and chipset features setup is lengthy, highly technical and beyond the scope of this manual. Below are abbreviated descriptions of the functions in this setup menu. You can look on the world wide web for helpful chipset and RAM configuration information including AWARD's web site at <http://www.award.com>.

A. DRAM Data Integrity Mode

BIOS automatically detects the presence of ECC DIMMs (72-bit modules). However, to take advantage of ECC you must set this function at "ECC." If any non-parity DIMMs are installed, the memory operates in non-parity mode only and this function must be set at "Non-ECC."

B. System BIOS Cacheable

Enabling this function allows caching of the system BIOS ROM at F0000h-FFFFFh, resulting in better system performance. However, if any program writes to this memory area, a system error may result. Caching the system BIOS results in better performance than shadowing the system BIOS as discussed in Section 3-2.

C. Video BIOS Cacheable

Enabling this function allows caching of the video BIOS ROM at C0000h-C7FFFh, resulting in better video performance. However, if any program writes to this memory area, a system error may result. Caching the video BIOS results in better performance than shadowing the video BIOS as discussed in Section 3-2.

D. 8-bit I/O Recovery Time & 16-bit I/O Recovery Time

Back-to-back CPU or PCI master originated 8-bit and 16-bit cycles have an arbitrary delay of at least 3.5 system clock cycles. This category is used to add additional recovery delay between 8-bit and between 16-bit cycles. This delay takes place because the PCI bus is much faster than the ISA bus. The options are 1 to 8 and N/A.

E. Memory Hole at 15M-16M

Enabling this function will reserve the memory address space between 15MB and 16MB for ISA expansion cards. However, enabling this function will result in not allowing the system to have access to memory above 16MB. Please note that some expansion cards require this setting to be enabled.

F. AGP Aperture Size (MB)

This function determines the amount of system memory that is given to the AGP card. Options range from 4MB to 256MB. This is a dynamic memory allotment in that the AGP card will only use the amount of memory that it needs. The remaining memory not in use will be available for the system to use. For example, if 16MB are allotted to the AGP card and the card only needs 8MB, the remaining 8MB will be available for system use.

G. Power Failure Recovery

Computers using an ATX power supply do not turn back on after the power source to the computer unexpectedly fails (i.e. electricity outage). Enabling this setting will allow the system to always turn back on after a power failure. This is especially important for computers that must be on 24 hours per day.

H. Spectrum Spread

When Enabled this function will cause lower EMI by spreading the system frequency spectrum. While this function decreases EMI, system stability may be slightly compromised. Choosing Smart Clock will turn off the AGP, PCI, and SDRAM clocks when not in use. Smart Clock does not perform a spectrum spreading function.

I. Flash BIOS Protection

The mainboard manufacturer developed BIOS protection technology that protects the System BIOS from accidental corruption by unauthorized users or computer viruses. When enabled, the BIOS data cannot be changed when attempting to update BIOS with the the FLASH utility. When disabled, the BIOS data can be updated by using the FLASH utility.



To Pass the Windows 95 SCT testing, this item should be disabled.



Please note that when disabling this setting, the system BIOS is vulnerable by intrusion of computer viruses. It is recommended to disable this setting only temporarily while updating your system's BIOS.

J. CPU Setup

The mainboard manufacturer developed *SeePU* technology that allows you to easily change your CPU's **clock multiplier factor** and **CPU Bus frequency** in BIOS. Refer to Section 2-3 for details.

3-4 Power Management Setup

This section provides information on the Green PC power management functions. By choosing the Power Management Setup option from the CMOS Setup Utility menu (Figure 3-1), the screen below is displayed. This sample screen contains the manufacturer's default values for the mainboard.

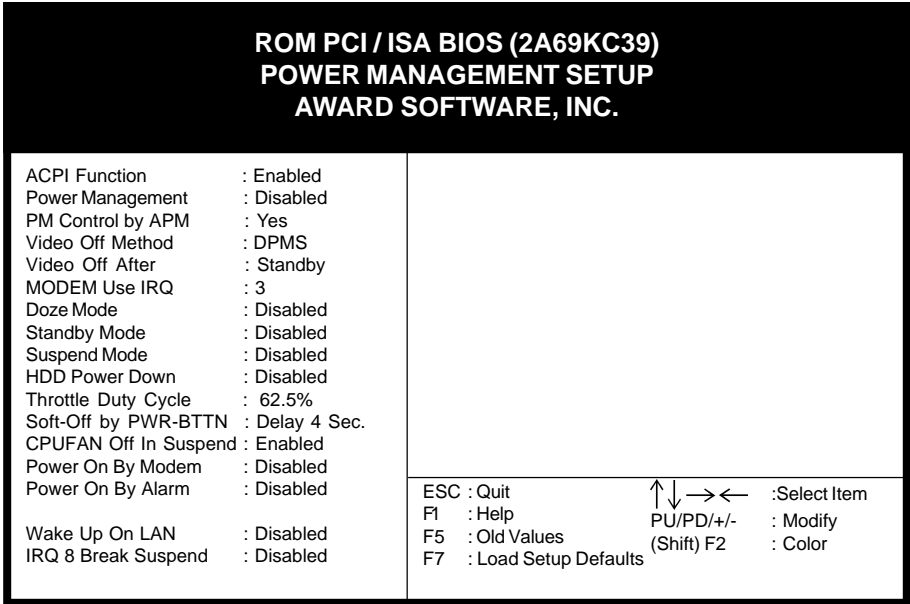

Figure 3-5 Power Management Setup Screen

A. Advanced Configuration Power Interface (ACPI)

ACPI management enables the operating system to control the amount of power given to each device attached to the computer. With ACPI, the operating system can turn off peripherals devices, such as CD-ROM players, when they are not in use.

B. Power Management

Power management allows the computer to save electricity when it is not in use by entering increasingly deep power saving modes as shown by the diagram below.

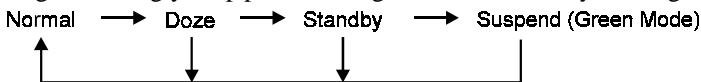

Figure 3-6 Power Saving Mode Flow Chart

The computer runs in Normal operation mode until the Doze timer expires, at which point the computer enters Doze mode. If no external activity occurs, the computer will go into Standby and Suspend modes when their respective timers expire. If external activity occurs, the computer will wake up from Power Management and return to Normal mode. To activate the function, set Power Management to Maximum Saving, User Define, or Minimum Saving described below. For a description of the power saving modes (Doze, Standby, and Suspend) see their descriptions below.

Disabled - Turns off the Power Management functions.

Max. Saving - All timers are set at the minimum value of one minute to maximize power saving.

Min. Saving - All timers are set at the maximum value of one hour for minimal power saving.

User Define - User can configure the timer to a desired time according to the values available.

- ✎ Note that enabling the Power Management function will result in enabling the HDD Power Down function (Max Saving = 15 min, Min Saving = 1 min). The HDD Power Down function is not part of the Power Management scheme as indicated in Figure 3-6. Refer to the Standby Mode, Suspend Mode, and HDD Power Down descriptions below for more information on hard drive power management.

C. PM Control by APM

This function allows software other than BIOS to control Power Management features. Enable this function in BIOS and make sure APM (Advanced Power Management) is present. For example, run the Power utility program located in the DOS directory, C:\DOS\POWER.EXE to use Power Management features under DOS. For Windows 3.1x and Windows 95, you need to install Windows with the APM feature.

D. Video Off Method

This function serves as both a screen saver and power saver for monitors. See the next function, Video Off After, for setting the video timer.

Blank - BIOS will only blank the monitor's screen. The electricity saved in this mode is negligible and this function is only used as a screen saver to prevent screen damage while the screen is on but not in use.

V/H SYNC+Blank - The system turns off the vertical and horizontal synchronization ports, writes blanks to the VGA buffer and the monitor's electron gun turns off. This function requires a monitor with Green features in order to take advantage of the power saving function. If you enable this function and do not have a Green monitor, the result will be the same as if you had selected Blank. This function serves as both a screen saver and an electricity saver.

DPMS Supported - Select this option if your video card supports the Display Power Management Signaling (DPMS) standard (i.e., you have a monitor that supports Green features). Use software supplied by your video subsystem to set video power management options.

E. Video Off After

This setting determines when the monitor enters power saving mode. As the function name indicates, the monitor enters the power saving mode after the chosen event expires. The Power Management function must be enabled to use this function.

F. Modem Use IRQ

If your computer has a modem, use this function to tell BIOS which IRQ is being occupied by the modem card. When the system is in Green mode, the modem requires an IRQ assignment to wake up the system and perform tasks. This assignment is compliant with the APM 1.2 specification and is to be used in coordination with APM 1.2 compliant operating systems.

G. Doze Mode

The Power Management function must not be set to disabled to enable this function. If no interrupts have occurred and the Doze timer expires, system will enter Doze mode. In Doze mode, the CPU clock runs at a lower speed while all other devices operate normally.

- ✎ Power saving modes achieved in lower power saving states will either be maintained or enter higher power saving modes when switching to higher power saving states. For example, the CPU clock will not switch back to normal in Standby mode. It will maintain a decreased rate in Standby Mode and turn off in Suspend Mode.

H. Standby Mode

The Power Management function must not be set to disabled to enable this function. If the system runs in Doze mode and the Standby timer expires, the system will enter Standby mode. In Standby mode, the hard disk drive and the monitor shut off while all other devices still operate at full speed. Note that the Video Off and HDD Power Down functions in Figure 3-5 provide the same power saving options found in Standby mode. The priority for determining which function controls power saving for the monitor and hard drive is determined by which timer expires first.

I. Suspend Mode

The Power Management function must not be set to disabled to enable this function. If the system runs in Standby mode and the Suspend timer expires, all devices regulated by power management will shut off and the CPU speed will be 0 MHz.

J. HDD Power Down

The Power Management function must not be set to disabled to enable this function. When the HDD idle time has elapsed, BIOS sends a command to the hard disk to turn off the motor. Set a time between 1 and 15 to indicate time required to wait before the hard drive enters a power saving mode. Some old hard drives may not support this function.

K. Throttle Duty Cycle

When the system enters Doze mode, the CPU clock runs only part of the time. You may select the percent of time that the clock runs.

L. Soft-Off by PWR-BTTN

When set to Delay 4 Sec., this function allows the power button to put the system in Suspend, a power saving mode. See Section 2-4 for operation instructions of the over-ride power button operation which puts the system in Suspend mode. When set to Instant-Off the Soft-Off by PWR-BTTN function is disabled and the computer turns completely off when the power button is pressed.

M. CPUFAN Off In Suspend

When enabled, this function turns off the CPU fan when the computer is in suspend mode.

N. Power On By Modem

When enabled, a modem that receives a call will wake up the system from soft off and green mode. You should connect the modem to the COM port and turn on the resume event in green mode.

O. Power On By Alarm

When enabled, this setting allows the system to turn back on at a designated time of the month. User must designate date of month and time of day. This function is only available when using an ATX power supply and the Software Power-Off function to turn off the computer. See the Software Power-Off feature in Section 2-4 of this manual for instructions.

P. Wake Up On LAN

Enable this selection to use the Wake Up On LAN function discussed in Section 2-4 of this manual.

Q. IRQ8 Break Suspend

Enabling this setting turns the monitoring of IRQ8 (the Real Time Clock) On so it does not awaken the system from Suspend mode.

3-5 PnP/PCI Configuration

This section provides IRQ and DMA setting information. By choosing the PnP/PCI Configuration option from the CMOS Setup Utility menu (Figure 3-1), the screen below is displayed. This sample screen contains the manufacturer's default values for the mainboard.

ROM PCI / ISA BIOS (2A69KC39)			
PNP/PCI CONFIGURATION			
AWARD SOFTWARE, INC.			
PnP OS Installed	: No	Slot 1 Use IRQ No.	: Auto
Resources Controlled By	: Manual	Slot 2 Use IRQ No.	: Auto
Reset Configuration Data	: Disabled	Slot 3 Use IRQ No.	: Auto
IRQ-3 assigned to	: PCI/ISA PnP	Used MEM base addr	: N/A
IRQ-4 assigned to	: PCI/ISA PnP	Assign IRQ For USB	: Enabled
IRQ-5 assigned to	: PCI/ISA PnP		
IRQ-7 assigned to	: PCI/ISA PnP		
IRQ-9 assigned to	: PCI/ISA PnP		
IRQ-10 assigned to	: PCI/ISA PnP		
IRQ-11 assigned to	: PCI/ISA PnP		
IRQ-12 assigned to	: PCI/ISA PnP		
IRQ-14 assigned to	: PCI/ISA PnP		
IRQ-15 assigned to	: PCI/ISA PnP		
DMA-0 assigned to	: PCI/ISA PnP	ESC : Quit	↑ ↓ → ← : Select Item
DMA-1 assigned to	: PCI/ISA PnP	F1 : Help	PU/PD/+/- : Modify
DMA-3 assigned to	: PCI/ISA PnP	F5 : Old Values	(Shift) F2 : Color
DMA-5 assigned to	: PCI/ISA PnP	F7 : Load Setup Defaults	
DMA-6 assigned to	: PCI/ISA PnP		
DMA-7 assigned to	: PCI/ISA PnP		

Figure 3-7 PCI & ONBOARD I/O Setup Screen

A. PnP OS Installed

If you want to install a PnP compatible OS (such as Windows 95) set to Yes.

B. Resources Controlled By

When set to Manual the system BIOS will not refer to the ESCD for IRQ & DMA information. Instead, it will refer to the items in the setup menu for assigning IRQ & DMA. When set to Auto the system BIOS will refer to the ESCD for all legacy information.



ESCD(Extended System Configuration Data) provides a detailed format of the configuration data structures stored in flash memory. Each data

structure defines the resources used by a device or a card in the system. This includes legacy and PCI/ISA PnP devices.

C. Reset Configuration Data

When enabled the system BIOS will clear/reset the ESCD during POST. After clearing the ESCD, the BIOS will then change this item's value to Disabled. Otherwise, the ESCD data will become useless.

D. IRQ#/DMA# assign to

When resources are controlled manually, you can assign each system interrupt & DMA channel for "Legacy ISA" or "PCI/ISA PnP" card used.

While using **Legacy ISA Card**(non-PnP ISA card), please set it's necessary corresponding resources (INT#, DMA#) from "PCI/ISA PnP" to "Legacy ISA."

- ☞ All ISA non-PnP devices are legacy devices that select resources (I/O Addr., INT# or DMA#) by using hardware jumpers.
- ☞ IRQ-3/4/7/12/14/15 have been set as default for on board devices (COM2, COM1, Printer port, PS/2 mouse, IDE1 and IDE2).

E. Used MEM base addr

This function devotes a space of memory (8K, 16K, 32K, 64K) for any peripheral that has a high memory requirement. This is also used to designate memory space for legacy ISA cards. The settings C800~DC00 are used to designate point at which the memory will start being used. The default setting is N/A (disabled.)

F. Assign IRQ For USB

If USB is employed this function must be Enabled. Otherwise, disable this function to optimize Windows 95 IRQ resources for other IRQ usage.

3-6 Load Setup Defaults

Load Setup Defaults loads the default system values directly from the CMOS Setup Utility menu (Figure3-1). If the stored record created by the setup program becomes corrupted and therefore unusable, these defaults will be loaded automatically when you turn on the computer.

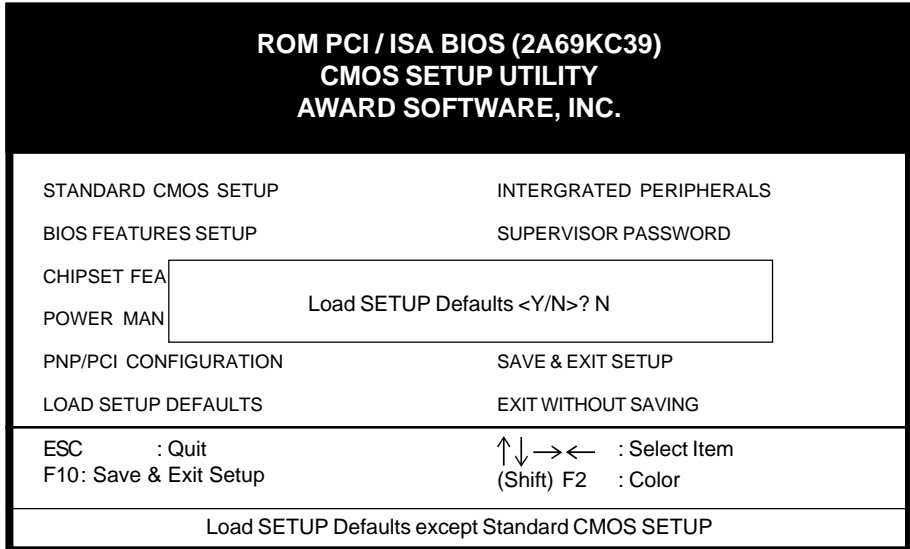

Figure 3-8 Load Setup Defaults Screen

3-7 Integrated Peripherals

This section provides information on setting peripheral devices. By choosing the Integrated Peripherals option from the CMOS Setup Utility menu (Figure 3-1), the screen below is displayed. This sample screen contains the manufacturer's default values for the mainboard.

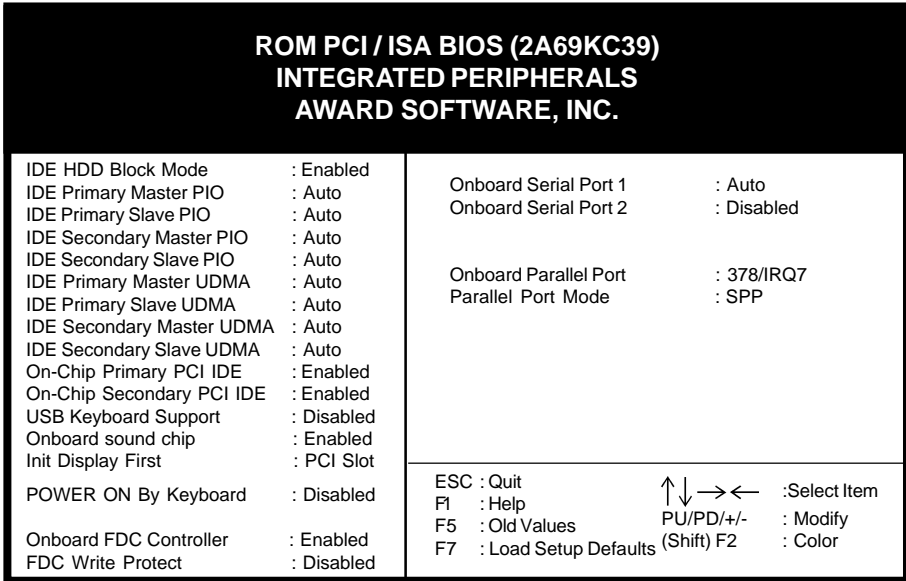

Figure 3-9 Integrated Peripherals Setup Screen

A. On Board IDE Control

IDE HDD Block Mode

Specify the maximum number of sectors that can be transferred at a time.

IDE Primary/Secondary Master/Slave PIO

The four IDE PIO (programmed Input/Output) fields let you set a PIO mode (0-4) for each IDE device that the internal PCI IDE interface supports. Modes 0 through 4 provide successively increased performance. In Auto mode, the system automatically determines the best mode for each device.

On-chip Primary/Secondary PCI IDE

You can set this to disable the On-chip IDE controller if you are going to add a higher performance IDE board.

B. USB Keyboard Support

If your current operating system doesn't support USB drivers (i.e., DOS) this function must be enabled for USB keyboard operation in these operating systems.

- ☒ When using a USB keyboard this function is automatically Enabled during bootup regardless of its setting in BIOS.

C. Onboard Sound Chip

This function must be enabled in order to use the onboard audio function. To terminate this function set it to disable.

D. Init Display First

This function allows user to choose between AGP slot or VGA slot to initialize Display first .

E. Power On By Keyboard

Set to Disabled to control your computer's power by the button on your system case. Set this function to Any Key to turn on the computer by touching any key on the keyboard. If you set this function to Hot Key or Password you must designate the keystrokes that will turn on the computer. Note that the power button is always able to turn on the computer regardless of how this function is set.

- ☒ If you have forgotten your password, you must remove the power cable from the ATX power supply connector and clear the CMOS data as discussed in Section 2-4 to clear the password.

3-8 Supervisor Password & User Password Setting

There are four different variables that control password settings. The first two are located under the Security Option function in BIOS Features Setup Menu (Figure 3-3). When the Security Option function is set to Setup, a password is required to enter BIOS and change BIOS settings. When the Security Option function is set to System, a password is required to enter both BIOS and the the computer's operating system (for example Windows 95) found on the boot drive. This is shown in Figures 3-10 and 3-11.

The third and fourth variables are user password and supervisor password selected in BIOS (Figure 3-1). The main purpose of separating user and supervisor is to allow only the supervisor to have control over the settings in BIOS. The user, on the other hand, is only allowed to access the computer's operating system and change the user password in BIOS (See Figure 3-11 below). Note that when there is no supervisor password set, the user password controls access to all BIOS settings (See Figure 3-10 below).

A. Set Either Supervisor Password or User Password

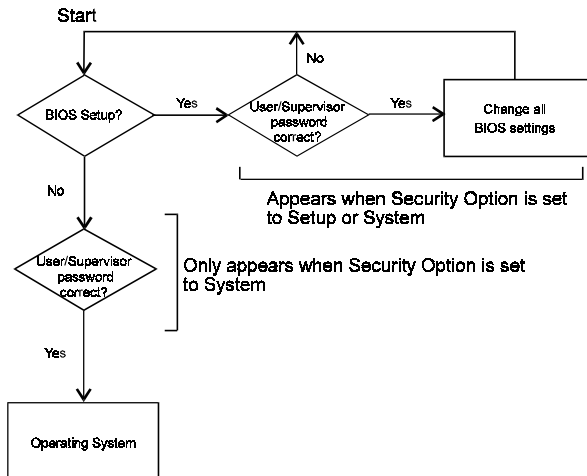

Figure 3-10 Set Either Supervisor or User Password

B. Set Both Supervisor Password and User Password

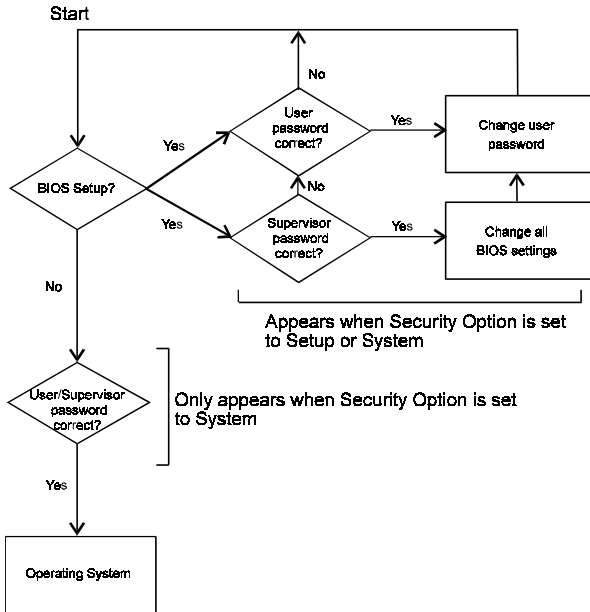

Figure 3-11 Set Both Supervisor and User Password

3-9 IDE HDD Auto Detection

This utility can automatically detect IDE hard disk type and parameters. The detection process take about 5 seconds for each physical drive. After the utility detects the disk drive, type Y and press [Enter] to automatically load the parameters in the Hard Disk section of the Standard CMOS Setup menu. Otherwise, leave the option set at N and press [Enter] or the [Esc] key to skip the detected drive. After detecting your hard drive(s), return to the Standard CMOS menu to check your settings.

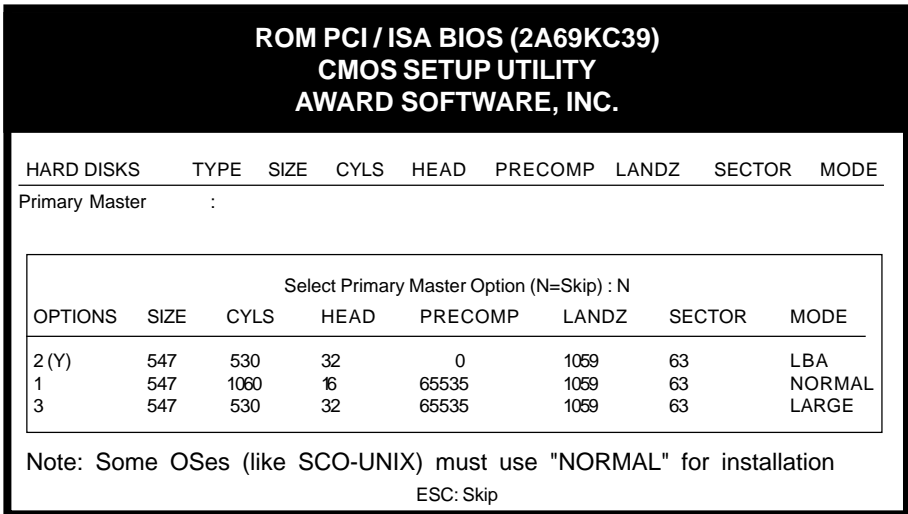

Figure 3-12 IDE HDD Auto Detection Screen

3-10 Save and Exit Setup

If you select this and type Y (for yes) followed by the [Enter] key, the values entered in the setup utilities will be recorded in the CMOS memory of the BIOS chip.

3-11 Exit Without Saving

Selecting this option and pressing Y followed by the [Enter] key lets you exit the Setup program without recording any new values or changing old values.

Brief Software Driver Guide

The Mainboard Software Guide is found on the CD-ROM that is enclosed with your mainboard and is a PDF file which must be viewed with Adobe's freeware called Acrobat® Reader. The Acrobat Reader software is also included on the same CD-ROM. See the Readme.txt file in the CD-ROM's root directory for installation instructions of the Acrobat Reader. The Mainboard software guide discusses the following items:

The following items are discussed in the PDF files:

- Bus Master/PIO IDE Driver Installation
- Sound Driver and Utility Installation
- Graphics accelerator Driver and Utility Installation
- USB Driver Installation
- Removing the Exclamation and/or Question Marks From the Windows 95 Device Manager Menu
- Updating Your System BIOS
- Installing and Using a Desktop Management Interface (DMI) Utility



Memo

Chapter 5

ESS Maestro-2 Audio Sub-system

5-1 Features

- ESS Maestro-2 audio chip with 64 voice wavetable synthesizer.
- Up to 20-bit ADC/DAC audio resolution.
- 500-MIPS-equivalent processor performance to accelerate multi-stream PC audio.
- Intergrated Spatializer 3D effects Processor.
- Complies with Microsoft's ACPI 1.0 and PPMI 1.0 (D0~D3)
- I²S/Zoomed video support.



5-2 Sound Driver and Utility (See Chapter 4)

5-3 CD-ROM Audio-in Connection (See Section 2-4)



Please note that the 3D button is not yet supported by *AUDIO Rack*. Don't use this button.



Memo

ATI RAGE PRO Video Sub-system

The 3D RAGE PRO is a highly integrated controller. Incorporated within this single chip are 2D, 3D and video accelerators, palette DAC, and quadruple clock synthesizer. This multi-function intergrated controller delivers superior 3D performance and enhancements to MPEG-2 motion compensation

6-1 Features

- AGP 1.0 compliant with both 1X (66MHz) and 2X (133MHz) support with pipelining and sideband address support
- Intergrated 3D, 2D, and Video accelertors with palette DAC and quad-clock synthesizer in one single chip
- Full support of Direct 3D texture lighting
- DDC1 and DDC2+ Plug and Play monitor support
- Power management for full VESA Display Power Management Signaling (DPMS), and EPA Energy Star compliance. Also, register support for controller power reduction and DAC power down
- 128-level command FIFO assures fast response to host command transfers for maximum CPU/host bus/controller efficiency and concurrent operation
- 32-bit wide memory mapped registers

6-2 Memory

- 4MB SGRAM at up to 100MHz memory clock, providing up to 800MB/Sec bandwidth

6-3 Operating Requirements

- To take advantage of the AGP 2x mode(133MHz), you must use Windows 95 version OSR2.1 or later. Make sure to install USBSUPP.EXE file from Microsoft

6-4 Driver and Utility Installation

- Graphics accelerator driver and Utility Installation (See Chapter 4)

6-5 Jumper Setting

- Onboard VGA (Enabled/Disabled) Jumper (See Section 2-4)

6-6 Reference

Direct3D

- Direct3D is the next generation of real-time, interactive 3D technology for mainstream computer user on internet. Direct 3D is a complete set of real-time 3D graphics services that delivers fast software-based rendering of the full 3D pipeline (transformations, lighting and rasterization) and transparent access to hardware acceleration. Direct 3D is fully scalable, enabling all or part of the 3D rendering pipeline to be accelerated by hardware.

On Board I/O Addresses & IRQ Maps

System Resource	IRQ	I/O Address
1. Timer	IRQ0	040, 043
2. Keyboard	IRQ1	060, 064
3. Programmable INT	IRQ2	0020, 0021, 00A0, 00A1
4. COM2(B)	IRQ3	2F8, 2FF
5. COM1(A)	IRQ4	3F8, 3FF
6. Floppy	IRQ6	3F0, 3F7
7. LPT1	IRQ7	378, 37F
8. Real Time Clock	IRQ8	070, 071
9. PS/2 Mouse	IRQ12	060, 064
10. Math coprocessor	IRQ13	0F0, 0FF
11. IDE 1	IRQ14	1F0, 1F7
12. IDE 2	IRQ15	170, 177

~~IRQ 5, 9, 10 and 11 are available for interface cards.~~



Memo

Quick Connector and Jumper Reference

CN4: Infrared connector

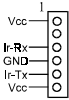

CN5: Chassis intrusion monitoring connector

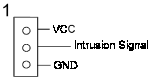

CN7: WOL (Wake-on-LAN) Conn.



CN8: Front panel connector set

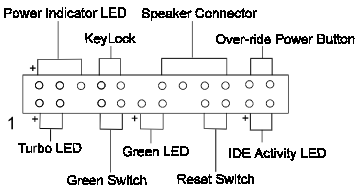

CN9: Creative's SB-Link connector (links AWE64D with PCI Bus Mastering)

FAN1/FAN2: CPU/System cooling fan connector



JP1: CD-ROM audio in

JP8: FS connector

JP9: Clear CMOS data jumper
 1~2 : Normal (default)
 2~3 : Clear CMOS data

Back Panel I/O Connector

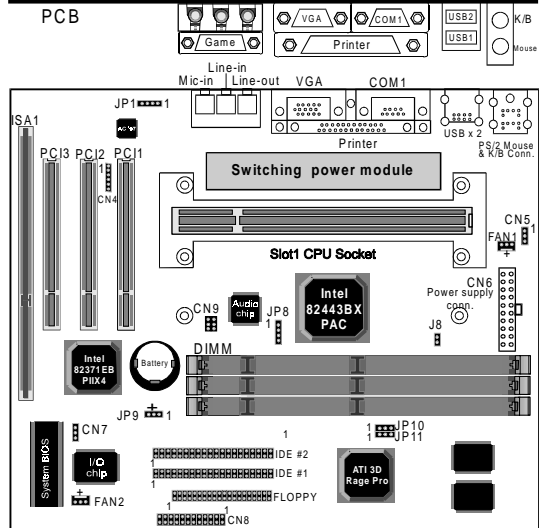

SeePU (Jumper free CPU installation) setting table

CPU Type	CPU Speed		
	External Clock	Frequency Ratio	Internal Clock
Pentium II processor	66	3.5	233
		4	266
		4.5	300
	100	5	333
		3.5	350
		4	400
		4.5	450

J8: External clock frequency jumper
 Short : CPU (default)
 Open : 100 MHz

JP10/JP11: On board VGA jumper
 1~2 : Disabled
 2~3 : Enabled (default)



Memo