



Declaration of Conformity

According to 47 CFR, Parts 2 and 15 of the FCC Rules

The following designated product:

EQUIPMENT: MAINBOARD

MODEL NO. : 6AJA4/6AJR4

is a Class B digital device that complies with 47 CFR Parts 2 and 15 of the FCC Rules. Operation is subject to the following two conditions:

1. This device may not cause harmful interference.
2. This device must accept any interference received, including interference that may cause undesired operation.

This declaration is given to the manufacturer:

CHAINTECH-EXCEL COMPUTER INC.

4427 Enterprise St. Fremont, CA 94538, U.S.A.

<http://www.chaintech-excel.com>

Chaintech President: Simon Ho

Signature: 



Federal Communications Commission Statement

This device complies with FCC Rules Part 15. Operation is subject to the following two conditions:

- * This device may not cause harmful interference
- * This device must accept any interference received, including interference that may cause undesired operation.

This equipment has been tested and found to comply with the limits for a Class B digital device, pursuant to Part 15 of the FCC Rules. These limits are designed to provide reasonable protection against harmful interference in a residential installation. This equipment generates, uses and can radiate radio frequency energy. If this equipment is not installed and used in accordance with the manufacturer's instructions, it may cause harmful interference to radio communications. However, there is no guarantee that interference will not occur in a particular installation. If this equipment does cause harmful interference to radio or television reception, which can be determined by turning the equipment off and on, the user is encouraged to try to correct the interference by one or more of the following measures:

- * Reorient or relocate the receiving antenna.
- * Increase the separation between the equipment and receiver.
- * Connect the equipment to an outlet on a circuit different from that to which the receiver is connected.
- * Consult the dealer or an experienced radio/TV technician for help.

The use of shielded cables for connection of the monitor to the graphics card is required to assure compliance with FCC regulations. Changes or modifications to this unit not expressly approved by the party responsible for compliance could void the user's authority to operate this equipment.

Canadian Department of Communications Statement

This digital apparatus does not exceed the Class B limits for audio noise emissions from digital apparatuses set out in the Radio Interference Regulations of the Canadian Department of Communications.

Manufacturer's Disclaimer Statement

The information in this document is subject to change without notice and does not represent a commitment on the part of the vendor. No warranty or representation, either expressed or implied, is made with respect to the quality, accuracy or fitness for any particular purpose of this document. The manufacturer reserves the right to make changes to the content of this document and/or the products associated with it at any time without obligation to notify any person or organization of such changes. In no event will the manufacturer be liable for direct, indirect, special, incidental or consequential damages arising out of the use or inability to use this product or documentation, even if advised of the possibility of such damages. This document contains materials protected by copyright. All rights are reserved. No part of this manual may be reproduced or transmitted in any form, by any means or for any purpose without expressed written consent of its authors. Product names appearing in this document are mentioned for identification purposes only. All trademarks, product names or brand names appearing in this document are registered property of their respective owners.

Printed in Taiwan

January 2001

100% POST-CONSUMER
RECYCLED PAPER 

Table of Contents

Chapter 1 Introduction	1
1-1 Product Specifications	1
1-2 Product Feature	4
1-3 Package Content	5
Chapter 2 Hardware Setup	7
2-1 Introduction to Jumpers	7
2-2 Installing a CPU in a Socket 370	8
2-3 Setting Your CPU's Parameters.....	8
2-4 Connector and Jumper Settings.....	10
2-5 Main Memory Configuration	18
Chapter 3 Award BIOS Setup Program	21
3-1 Standard CMOS Setup	22
3-2 Advanced BIOS Features Setup	25
3-3 Advanced Chipset Setup	28
3-4 Integrated Peripherals	31
3-5 Power Management Setup	33
3-6 PnP/PCI Configuration	36
3-7 PC Health Status.....	37
3-8 Frequency/Voltage Control.....	38
3-9 Load Fail-Safe Defaults	39
3-10 Load Optimized Defaults	40
3-11 Supervisor Password & User Password Setting	41
3-12 Save and Exit Setup	42
3-13 Exit Without Saving.....	42
Chapter 4 Brief Software Driver Guide	43
 Appendices	
Appendix I On Board I/O Addresses & IRQ Maps	45
Appendix II Embedded Flash Utility	47
Appendix III HDD Instant Recovery Utility.....	49
Appendix IV TwinBIOS Technology (optional)	51
Appendix V IDE RAID Technology (optional)	53
Appendix VI CMedia 8738 Audio Subsystem (optional)	55

Feature Explanations

Software Power-off Control	13
Over-ride Power Button	13
Blinking LED in Suspend Mode	13
Power On By PCI Card	35
Power On By Modem/LAN	12/35
Power On By Alarm	35
Poly-fuse Over Current Protection	12

Chapter 1

Introduction

1-1 Product Specifications

❑ Processor

- Supports up to Socket-370 Intel processors up to 1GHz
- Supports 66/100/133 MHz system clock speeds
- High efficiency Switching Power Module (VRM v8.4 compliant)

❑ Chipset

- VIA Apollo Pro133A (**82C694X+82C686A**) or (**82C694X+82C686B support ATA-100**) dual chip AGPset

❑ DRAM Memory

- Three 3.3V 168-pin DIMM sockets support up to 768MB
- Supports PC-133 SDRAM, and VCM
- Supports Sync. & Asyn. Host memory clock scheme
- Provides single-bit ECC capability

❑ Expansion Slots

- One AMR slot (Rev 1.0 compliant) for cost effective soft modem riser
- One Universal AGP slot for both 2x/4x AGP at 3.3v or 1.5v (Rev 2.0 compliant)
- Five 32-bit PCI slots with full master sharing controller for IDE RAID share w/PCI #5 and Audio share w/PCI #4 (Rev 2.2 compliant)
- One 16-bit ISA slot (with sharing slot)

❑ 2Mb Boot-Block Flash ROM

- Award System BIOS, supports PnP, APM, DMI, ACPI & Multi-device booting features i.e. floppy, LS120, CD-ROM, HDD (IDE, SCSI), ZIP-ATAPI etc.
- Includes Trend ChipAway Virus protection for virus-free boot and virus free operating system
- BIOS Wonder technology including ChipAway Virus, Flash BIOS Write Protect, Embedded Flash Utility, Built-in Hard Disk Backup firmware
- Optional TWIN BIOS with Instant BIOS Recovery for triple BIOS insurance

❑ Embedded Ultra DMA-66 PCI IDE controller

- Supports two IDE ports up to 4 ATAPI devices
- Supports up to PIO Mode 4 up to 16.6MBps, Multi-Word Mode 4 up to 66MBps with bus mastering
- Optional VIA VT82C686B ATA-100 support up to Multi Word Mode 5

❑ **Embedded Super I/O Functions**

- Three UARTs support two serial ports and IR function for HPSIR and ASKIR
- One parallel supports SPP/ECP/EPP
- One floppy disk drive connector supports up to 2.88MB, Japanese 3- Mode and 1Mbps transfer rate

❑ **Double Stack Back-Panel I/O Connectors with PC99 Colored Codes**

- PS/2 Mini-DIN keyboard and mouse ports
- Two Channel USB ports
- Two D-SUB 9-pin male serial ports
- One D-SUB 25-pin female Printer port
- One D-SUB 15-pin female Game/MIDI port
- Audio Line-out, Line-in (min. 0.5w), Mic-in jacks

❑ **Embedded PCI Audio Subsystem**

- Built-in Sample Rate Converter to ensure all internal operation at 48KHz
- Full-duplex operation for simultaneous recording and playback
- Built-in FM-emulation music synthesizer
- With external high quality AC'97 CODEC provides 90dB+ SNR CD quality audio
- Using wavetable data on the system memory
- Hardware SoundBlaster Pro for Windows DOS box and real-mode DOS legacy compatibility
- Complete software driver support for Win95/98/NT

❑ **Optional External PCI Audio Subsystem**

- CMedia 8738 audio chip w/ legacy audio SB16/Pro compatible
- Advanced 64-Voice Wavetable synthesizer
- Programmable independent sample rate from 4KHz to 48KHz for recording and playback
- Full-duplex operation for simultaneous recording and playback
- Supports MS DLS (Downloadable sample) level-1 technology with limitless variety of instrument samples using PC RAM
- Up to 8MB wavedata provides 128 GM, GS and WT-32 compatible instruments and 10 drum kits
- Supports HRTF 3D positional audio with MSDS, DS3D, DirectMusic, Aureal A3D and Creative EAX (Environment Audio Extensions) APIs
- Option of 4 or 6-Channel speaker audio support
- Optional supports 24-bit S/PDIF-in/out for digital audio (i.e. compressed AC3 data)
- Supports Fiber Optic module for Internet music, PC, and MD connections
- Supports MIDI and dual game ports
- Embedded 32OHM .5w earphone amplifier

❑ Embedded USB Controller

- USB host controller (UHCI v1.0 compliant) with Root Hub
- Four USB ports with over-current protection
- Optional USB riser with 2 additional USB ports

❑ Optional IDE Accelerator

- High Point HPT370 IDE controller
- Supports extra two UltraDMA-100 IDE ports with RAID 0, 1 and 0+1

❑ Embedded System Monitoring Hardware Subsystem

- 5 external voltage inputs for CPU Vcore, +12v, +5v, 2.5v and 3.3v (internal detecting)
- 2 temperature sensor with thermistor for CPU & System
- 2 Fan speed (CPU and System) monitoring and control with ON/OFF control in suspend

❑ Board Dimensions

- Standard ATX form factor, 305mm x 210mm, 4 Layers

❑ Switching Power Supply Requirement

Output Voltage	Max. Regulation Requirement	Min. Current Requirement (Amps)
+12V	+/- 5%	5.5
+5V	+/- 5%	20
+3.3V	+/- 5%	15
-5V	+/- 10%	0.5
-12V	+/- 10%	0.5
+5VSB	+/- 5%	0.75

Table 1-1



3.3V at 15Amps is necessary to guarantee full loading operation because some AGP cards and memory modules have high current consumption.

1-2 Product Features

- Innovative SeePU technology for jumperless CPU installation
- Superior Overclocking capability with up to 150MHz frequency, Subtle 1MHz frequency
- Complete CPU protection with OVT (Over Voltage Protect) and OCP (Over Current Protect) technology
- Embedded System Monitor Hardware
- Poly-fuse over-current protection with error warning for keyboard circuitry
- Complete Data Security:
 - *Flash BIOS write protection against unauthorized access
 - *Trend ChipAway Virus for a 100% virus free system boot-up
- Advanced Management Features:
 - * Power-on events:
 - WOL(Wake-on-LAN) network card, Modem ring, RTC Alarm
 - * Software power-off control for Win95
 - * Over-ride power button
 - * Three states advanced Power-failure recovery: Always On, Always Off, Last state
 - * Blinking Power-LED in suspend
 - * Hardware Reset Protect

1-3 Package Contents

This product comes with the following components:

- ❑ One mainboard
- ❑ One 40-pin Ultra DMA-66/100 IDE connector ribbon cable (Figure 1-1)
 - * **Color coded connection for UDMA-66/100 cable**
 - Blue to mainboard, Gray to Master and Black to slave
- ❑ One 34-pin floppy disk drive ribbon cable (Figure 1-2)
- ❑ Optional AC3 Surround/Center + Bass jack extension. (Figure 1-3)
- ❑ One User's Manual
- ❑ One CD-ROM that includes
 - Award Flash EPROM Utility
 - Award DMI Utility for DOS
 - VIA Service Pack for Win9x/WinNT including Bus Master IDE drivers, AGP VxD and etc.
 - Audio drivers and Application for Win31, Win9x, NT4.0, Win2000 and Linux
 - Optional IDE RAID driver for Win98, NT and Win2000
 - VIA Sound Driver for DOS/Win95/98/NT
 - Optional **Value Pack 2001** software group including Norton AntiVirus, AutoSave, ADOBE ActiveShare, Acrobat Reader, Imagemore, X-stop, Appio and Ewalla.



Figure 1-1 UDMA-66/100 IDE cable



Figure 1-2 Standard Floppy cable

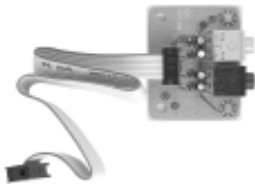

Figure 1-3 AC3 Surround/Center + Bass jack extension (Optional)

Memo

Chapter 2

Hardware Setup

If your mainboard has already been installed in your computer you may still need to refer to this chapter if you plan to upgrade your system's hardware.

! Be sure to disconnect the power cable from the power source before performing any work on your mainboard, i. e. installing a CPU, memory module, changing a jumper setting, etc. Not doing so may result in electrical shock!

2-1 Introduction to Jumpers

Jumpers are used to select between various operating modes. A jumper consists of a row of gold colored pins that protrude from the surface of the mainboard. It is important not to confuse jumpers with connectors or headers.

! Putting jumper caps on anything that is not a jumper may result in damaging your mainboard. Please refer to Section 1-3, Mainboard Layout, for the location of jumpers on your mainboard.

As indicated in Figure 2-1 below, a cap is used to cover the pins of a jumper, resulting in shorting those pins that it covers. If the cap is removed from the top of the pins, the jumper is left "open." The number 1 shown both in the diagram below and in all multiple pin jumper and header diagrams in this manual indicates the pin designated with the number 1. The numbering of the remaining pins follows in sequence.

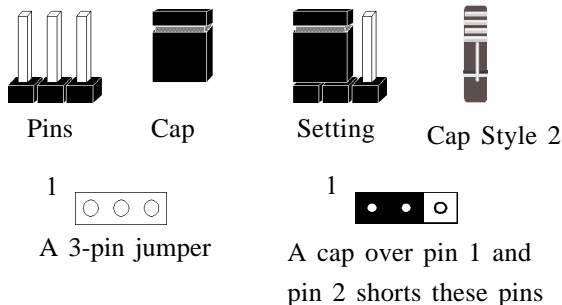

Figure 2-1

2-2 Installing a CPU in a Socket 370

The Intel Socket 370, designed for the Celeron and Coppermine processors, has been incorporated as a standard mainboard specification. To insert your CPU into Socket 370 please do the following:

1. Locate a small dot marked on the top surface of the CPU close to one of its corners. The same corner will also be cut off, leaving a noticeable notch in the CPU's corner. These markings indicate Pin 1 of the CPU.
2. Pull up the lever of Socket 370 so that it is perpendicular with the surface of the mainboard. Gently insert the CPU with Pin 1 at the same corner of Socket 370 that contains the end of the lever. Allow the weight of the CPU to push itself into place. Do not apply extra pressure as doing so may result in damaging your CPU. Snap the lever back into place.



Installing a heat sink with cooling fan is necessary for proper heat dissipation from your CPU. Failing to install these items may result in overheating and possible burn-out of your CPU.

2-3 Setting Your CPU's Parameters

This board support plug and play CPU configuration, if you install a CPU on this mainboard, the board will automatically detect and set CPU parameters. It is no longer necessary to make many jumper settings as on conventional mainboards.

1. After installing all your hardware into your PC system, turn on your system's power. Enter the CMOS Setup Utility by pressing the Delete key when your BIOS identification screen appears.
2. Move the cursor to Frequency/Voltage Control Setup menu and press Enter. Find the CPU bus frequency at the left hand side of the BIOS screen. Commands for operating the cursor in BIOS are found at the Bottom right of the BIOS screen.
3. Set the CPU bus frequency according to your processor's specifications.
4. Press Esc to return to the CMOS Setup Utility, press F10 to Save and Exit Setup and choose 'Y' to confirm. The system will automatically reboot and during startup you will see the correct CPU type shown on the screen.



You do not need to make voltage settings because *SeePU* automatically sets your CPU voltage.

Overclocking

Operating a CPU at a higher frequency than its specification allows is called overclocking. If the CPU frequency is set at a higher frequency than its specification allows, it may or may not run at that frequency, depending on the quality of your CPU and the extent to which the frequency has been overset. The mainboard manufacturer highly discourages overclocking as it may result in data loss, CPU burnout, system failure, etc.

Many Intel processors are frequency locked processors and are not able to perform overclocking. Regardless of whether the processor is a frequency locked, overclocking may cause some processors to hang when turning on the system. When the processor hangs, the screen remains blank and the system does not boot. To solve this problem, do the following.

1. Turn off the computer and then press and hold the Home key on your keyboard
2. Turn on your computer, wait for five seconds and then release the Home key.
3. Enter BIOS and reconfigure your CPU parameters as described in this section.

**CN6,CN14,
J2,J3,JP1**

**CN2,CN3,CN4,
JP3/JP4,JP7,JPX1**

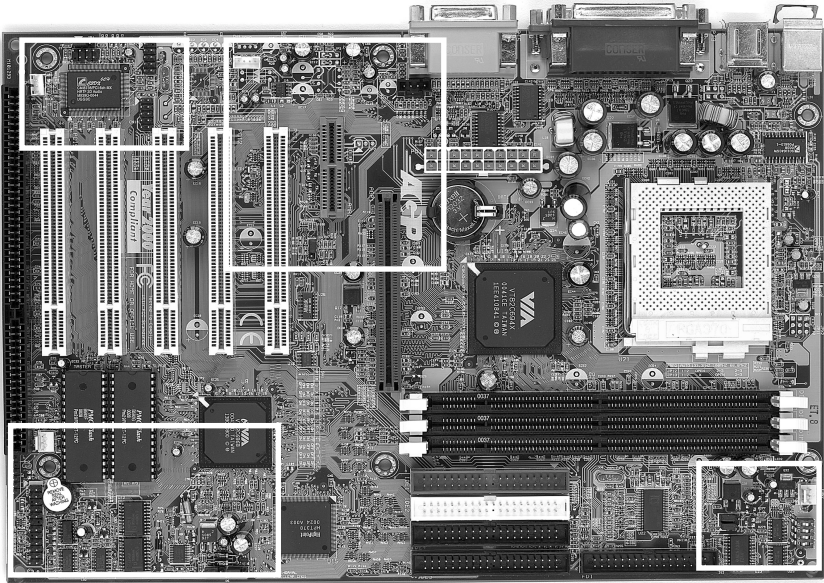

CN1,IR,FAN1,JP5,JP6

**JP12/JP13,
SW1,FAN2**

PS/2 Mouse

Printer Port

Game Port

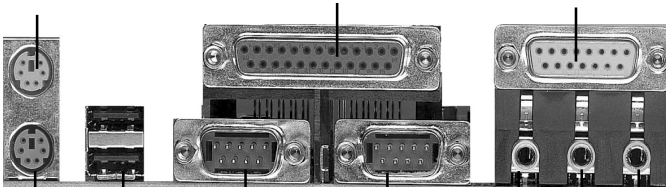

PS/2 Keyboard

USB 1/2

COM1

COM2

Line-out

Line-in

MIC

Jumper & Connector No.	Function	Page
PW1	ATX Power Supply Connector	12
JP1	Onboard Audio (Optional for C-Media)	15
JP3/JP4	Audio Line_out or Speaker_out	15
JP5	Boot BIOS Select (Optional for TwinBIOS)	15
JP6	Clear CMOS Data	16
JP7	Primary Audio CODEC Select (Optional)	16
JP12/JP13	CPU Bus Frequency	16
CN1	Over-ride Power Button Connector	13
	Power Indicator LED Connector	13
	Green Switch / Green LED Connector	14
	System Reset Switch Connector	14
	Speaker Connector	14
	IDE Activity LED Connector	14
	Turbo LED Connector	14
JPX1	IDE RAID Controller (Optional)	17
CN2	CD-ROM Audio_in Connector	17
CN3	Auxiliary CD-ROM Audio-in Connector	17
CN4	Audio Mono -in/out Connector (Optional)	17
CN6	WOL(Wake On LAN) Connector	18
CN14	USB 2/3 Connector	18
USB Ports	USB 0/1ports	18
IR	Infrared Connector	19
J2	Fiber Optical Connector (Optional)	19
J3	AC3 Surround/Center + Bass Connector (Optional)	19
SW1	CPU Clock Ratio Setting (Optional)	14
FAN1/2	System/CPU Cooling Fan Connector	19

2-4 Connector and Jumper Settings

Connectors are used to link the system board with other parts of the system, including the power supply, the keyboard, and the various controllers on the front panel of the system case.



The power supply connector is the last connection to be made while installing a mainboard. Before connecting the power supply, please make sure it is not connected to the power source.

ATX Power Supply Connector (PW1)

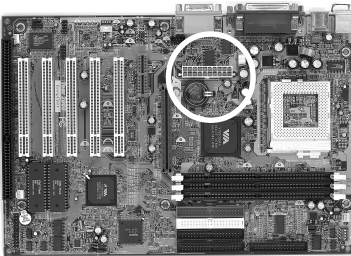

The power cord leading from the system's power supply to the external power source must be the very last part connected when assembling a system.



To support this function, a switching power supply with a minimum of **750mA 5VSB** is required.

12V	Ⓜ	Ⓜ	5V
5VSB	Ⓜ	Ⓜ	5V
PW-OK	Ⓜ	Ⓜ	-5V
Ground	Ⓜ	Ⓜ	Ground
5V	Ⓜ	Ⓜ	Ground
Ground	Ⓜ	Ⓜ	Ground
5V	Ⓜ	Ⓜ	PS-ON
Ground	Ⓜ	Ⓜ	Ground
3.3V	Ⓜ	Ⓜ	-12V
3.3V	Ⓜ	Ⓜ	3.3V

The ATX power supply provides a single 20-pin connector interface which incorporates standard +/-5V, +/-12V, optional 3.3V and Soft-power signals. The Soft-power signal, a 5V trickle supply is continuously supplied when AC power is available. When the system is in the Soft-Off mode, this trickle supply maintains the system in it's minimum power state.

Power-On By Modem

While in Soft-off state, if an external modem ring-up signal occurs, the system wakes up and can be remotely accessed. You may enable this function in BIOS's Power Management Setup menu.

Poly-fuse Over Current Protection

The poly-fuse protects the system from dangerous voltages the system might be exposed to via the keyboard or USB connectors. In case of such exposure, the poly-fuse will immediately be disconnected from the circuit, just like a normal fuse. After being disconnected for a certain period of time, the poly-fuse will return to its normal state, after which the keyboard or USB can function properly again. Unlike conventional fuses, the poly-fuse does not have to be replaced, relieving the user wasted time and inconvenience.

Front Panel Connector Set (CN1) A through F

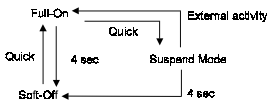
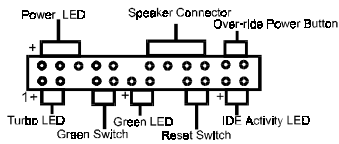
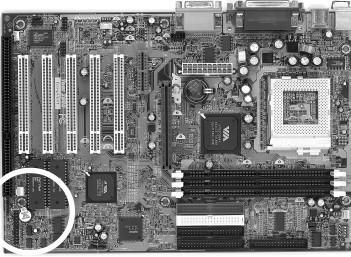

Over-ride Power Button Operation

Pin	Definition
1	+5V DC
2	No Connection
3	Ground

Software Power-Off Control

This mainboard can be powered down using the Windows 95/98 Software Power-Off function. To power down your computer, click the START button on the Windows 95/98 task bar. Select "Shut Down The Computer" and the system turns off. The message "It is now safe to turn off your computer" will not be shown when using this function.

Blinking LED in Suspend Mode

While in Suspend mode, the LED light on the front panel of your computer will flash. Suspend mode is entered by pressing the Override Power Button, pushing the Green button on your ATX case, or enabling the Power Management and Suspend Mode options in BIOS's Power Management menu.

A. Over-ride Power Button Connector

The power button on the ATX chassis can be used as a normal power switch as well as a device to activate Advanced Power Management Suspend mode. This mode is used for saving electricity when the computer is not in use for long periods of time. The Soft-OFF by PWR-BTTN function in BIOS's Power Management Setup menu must be set to "Delay 4 Sec." to activate this function.

When the Soft-OFF by PWR-BTTN function is enabled, pushing the power button rapidly will switch the system to Suspend mode. Any occurrence of external activities such as pressing a key on the keyboard or moving the mouse will bring the system back to Full-On. Pushing the button while in Full-On mode for more than 4 seconds will switch the system completely off. See Over-ride Power Button Operation diagram.

B. Power Indicator LED Connector

Plugging this connector into the lock on the front panel of the system case allows the lock to enable or disable the keyboard. This function provides limited security against casual intruders. The power indicator LED shows the system's power status. It is important to pay attention to the correct cables and pin orientation (i.e., not to reverse the order of these two connectors.)

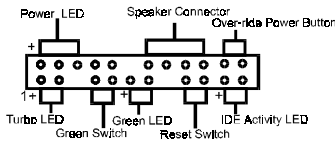
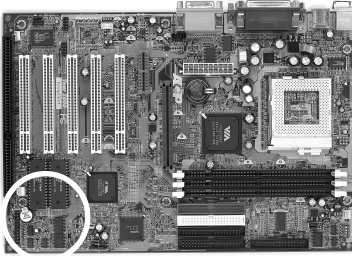

C. Green Switch/Green LED Connector

Some ATX cases provide a Green switch which is used to put the system in Suspend mode. In Suspend mode, the power supply to the system is reduced to a trickle, the CPU clock is stopped, and the CPU core is in it's minimum power state. The system is woken up whenever the keyboard or mouse is touched. The system resumes in different ways as defined by Power Management Setup screen in BIOS.

D. System Reset Switch Connector

This connector should be connected to the reset switch on the front panel of the system case.

Pin	Definition
1	System
2	GND

E. Speaker Connector

Pin	Definition
1	Speaker Signal
2	No Connection
3	No Connection
4	+5V DC

F. IDE Activity LED Connector

The IDE activity LED lights up whenever the system reads/writes to the IDE devices.

G. Turbo LED Connector

This mainboard does not have a Turbo/De-turbo speed modes. So the turbo LED will always light.

Optional CPU Clock Ratio Setting (SW1)

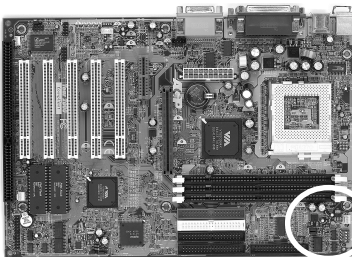

This feature allows you to set a CPU at a higher clock ratio than it's specification allows. it may or may not run at that ratio, depending on the quality of your CPU and the extent to which the ratio has been overset.

RATIO	3	3.5	4	4.5	5	5.5	6	6.5	7	7.5
1	ON	ON	ON	ON	ON	ON	OFF	OFF	OFF	OFF
2	ON	OFF	ON	OFF	ON	OFF	ON	OFF	ON	OFF
3	ON	ON	OFF	OFF	OFF	OFF	ON	ON	ON	ON
4	OFF	OFF	ON	ON	OFF	OFF	ON	ON	OFF	OFF

This option will not work with frequency lock CPU.

Optional Onboard Audio (JP1)

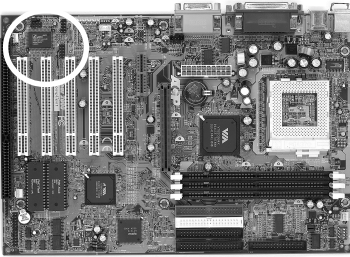

1 Enable 1 Disable

This function allows you to enable and disable the on board audio. You must set the jumper's cap to pins 1-2 to enable or set pins 2-3 to disable this function.

Audio Line_out or Speaker_out (JP3/JP4)

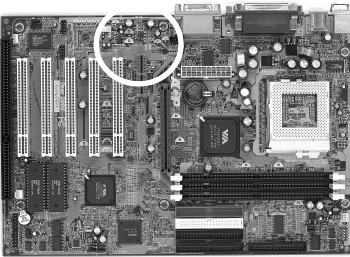

JP3 1 JP3 1
 JP4 Line_out JP4 Speaker_out (default)

This jumper allows you to select between audio line-out or speaker out function. Set both JP3 and JP4 pins to 1-2 for line-out function or set both JP3 and JP4 pins to 2-3 for speaker out function.

Optional Boot BIOS Select (JP5)

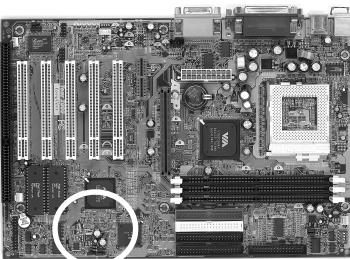

1 Boot BIOS select (default)
 1 BIOS 1 (Power on only)/
 BIOS 2 (Power on + Reset button)

This feature allows you to select a BIOS to boot up your system. Set the pin to 1-2 to enable Boot BIOS select in the BIOS Features Setup and then select either BIOS 1 or BIOS 2 for startup (see section 2-4). The feature also allows you to manually shift to another BIOS once the BIOS fail to boot. Set pin to 2-3 to boot from BIOS 1 and then press the power on button to boot up or press reset and power on button hold for 2-3 second and then release to boot from BIOS 2.

Clear CMOS Data (JP6)

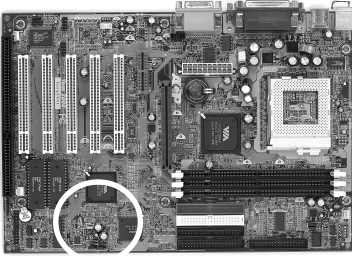

Normal (default)



Clear CMOS data

To clear the contents of the CMOS, please follow the steps below.

1. Disconnect the system power supply from the power source.
2. Set the jumper cap at location 2~3 for 5 seconds, then set it back to the default position.
3. Connect the system's power and then start the system.
4. Enter BIOS's CMOS Setup Utility and choose Load Setup Defaults. Type Y and press enter.
5. Set the system configuration in the Standard CMOS Setup menu.

Optional Primary Audio CODEC Select (JP7)

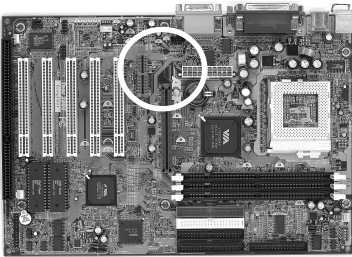

Onboard CODEC (Default)



AMR (Soft-Audio/Modem riser)

Short pin 1-2 to enable onboard AC`97 CODEC.
Short pin 2-3 to enable AMR (Soft Audio/Modem riser).

CPU Bus Frequency (JP12/JP13)

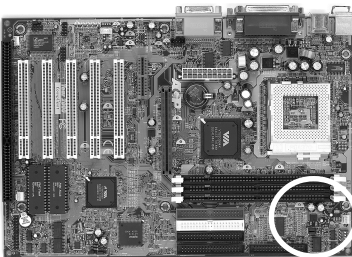

	JP12	JP13
Auto (default)	1 ~ 2	1 ~ 2
66MHz	2 ~ 3	2 ~ 3
100MHz	2 ~ 3	Open
133MHz	Open	Open

This jumper allows the CPU bus frequency to be determined either by the CPU or the user. Set both jumper cups to pin 1-2 (default) if you are not sure what frequency your CPU support.

Optional IDE RAID Controller (JPX1)

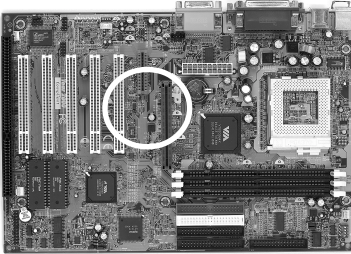

1 Enable (Default) 1 Disable

The mainboard (optional) support IDE RAID 0/1,0+1 feature. To use this function, set the jumper's cap to pins 1-2 to enable or set pins 2-3 to disable this function.

CD-ROM Audio-in Connector (CN2)

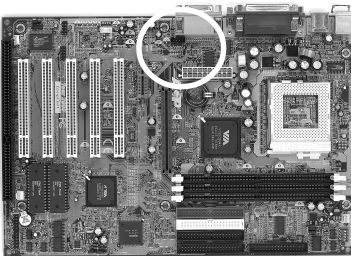

Use the audio cable enclosed with your CD-ROM disk drive to connect the CD-ROM to your mainboard. This will enable your CD-ROM's audio function.

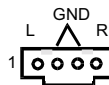

Auxiliary CD-ROM Audio-in Connector (CN3)

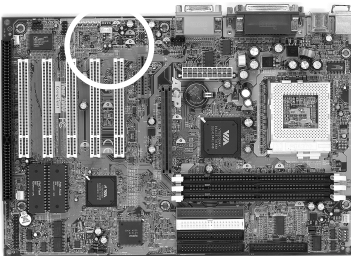

Use the auxiliary audio cable enclosed with your CD-ROM disk drive to connect the CD-ROM to your mainboard. This will enable your CD-ROM's audio function.

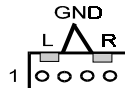

Optional Audio Mono -in/out Connector (CN4)

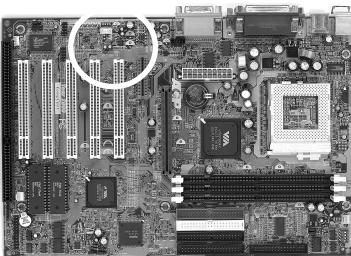

Use the mono audio cable enclosed with your CD-ROM disk drive to connect the CD-ROM to your mainboard. This will enable mono audio in/out function.

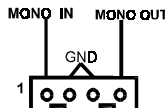

WOL (Wake-on-LAN) Connector (CN6)

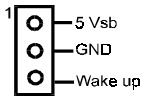
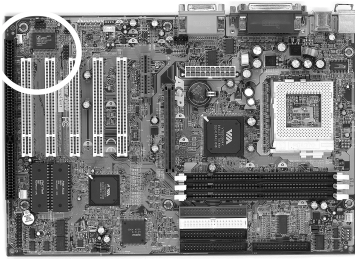

Enable the Wake Up On LAN selection in BIOS's Power Management Menu to use this function. The capability to remotely manage PCs on a network is a significant factor in reducing administrative and ownership costs. Magic Packet technology is designed to give WOL (Wake-on-LAN) capability to the LAN controller. When a PC capable of receiving wake up command goes to sleep, the Magic Packet mode in the LAN controller is enabled. When the LAN controller receives a Magic Packet frame, the LAN controller will wake up the PC. This header is used to connect an add-in NIC (Network Interface Card) which gives WOL capability to the mainboard.

USB Ports and USB 2/3 Connector (CN14)

USB 2/3 USB 0/1 ports

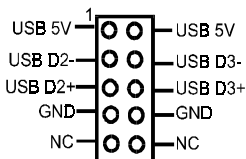
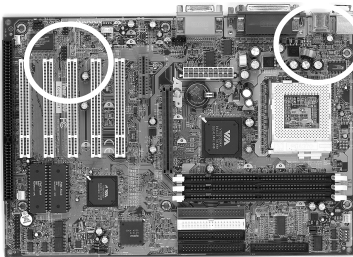

If you want to use a USB keyboard, you must enable the USB keyboard support function in BIOS's Integrated Peripherals menu (See Section 3-7). USB is an open industry standard, providing a simple and inexpensive way to connect up to 125 devices to a single computer port. Keyboards, mice, tablets, digitizers, scanners, bar-code readers, modems, printers and many more can all be used at the same time.

USB is a dynamically reconfigurable serial bus with an elementary data rate of 12Mbps. Based on off the shelf, low cost micro-controller technology, its modular layered software protocol supports sophisticated devices and application programs.

This board contains a USB Host controller and includes a root hub with two USB ports (meets USB Rev 1.0 spec.) and a connector for optional USB Adaptor (USB2/3). Four USB peripherals or hub devices are able to be connected.

Infrared Connector (IR)

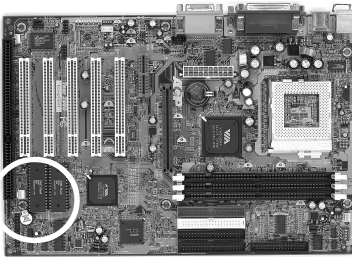

If you enable the COM2 Mode in BIOS's Integrated Peripherals menu the COM2 port will support IR functions.

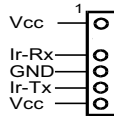

Optional Fiber Optical Connector (J2)

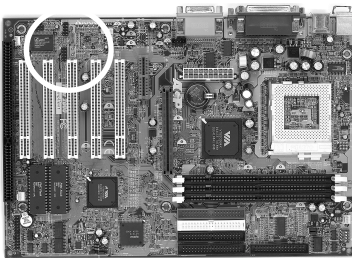

This connector supports fiber optic module for Internet music, PC, MD(Mini Disk) connections.

Optional AC3 Surround/Center + Bass Connector (J3)

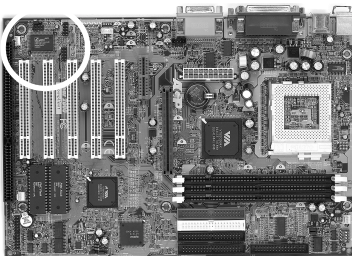

This connector is for Surround and Center+Bass speaker output ext. Plug in the optional AC3 Surround/Center+Bass jack extension into this connector. The black colored jack is for surround speaker output and the orange colored jack is for center+bass speaker output.

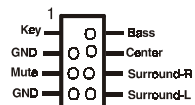

System/CPU Cooling Fan Connectors (FAN1/FAN2)

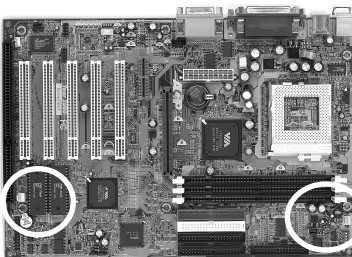

These added connectors allow the fan to draw their power from the mainboard instead of the disk drive connector.

The board's management extension hardware is able to detect the CPU and system fan speed in rpm (revolutions per minute). These connectors supports 3-pin cooling fans with minimum of 3500 RPM. The wiring and plug may vary depending on the manufacturer. On standard fans, the red is positive (+12V), the black is ground, and the yellow wire is the rotation signal.

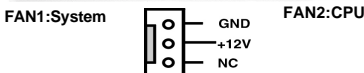

2-5 Main Memory Configuration

The DRAM memory system consists of three banks and the memory size ranges from **32~512 MBytes**. It does not matter which bank you want to install first.

DRAM Specifications

FSB	SDRAM Type	SDRAM Type	Max Memory
66	FSB	12ns or faster	1GB
	FSB+33	10ns or faster	
100	FSB-33	12ns or faster	
	FSB	10ns or faster	
	FSB+33	7.5ns or faster	
133	FSB-33	10ns or faster	
	FSB	7.5ns or faster	

DIMM type : 3.3V, unbuffered, registered, 64/72-bit SDRAM with SPD*

Module size: Single/double-side 32/64/128/256 MBytes

Parity : Either parity or non-parity

- ⚠ The compatibility with 512MB and Registered DIMM is still under testing and cannot be guaranteed.
- ⚠ This mainboard supports 3.3v, unbuffered, 4-clock, SDRAM DIMM only. Buffered, 5V, or 2-clock SDRAM DIMMs should not be used.
- ⚠ Due to loading anomalies, using DIMM with an 'n x 4' DRAM base on this mainboard is not recommended. For example, a DIMM that uses sixteen 16Mb x 4 devices should not be used.

SPD (Serial Presence Detect)

This is an EPROM that contains speed and design information about the memory module. The mainboard queries the module and makes adjustments to system operation based on what it finds.

ECC DRAM Capability

This mainboard can be configured to support ECC (Error Check and Correct) function when utilizing parity DIMM modules. To utilize the chipset's ECC features, you must use a 72-bit DIMM module. These modules are automatically detected during bootup. However, the user must configure the DRAM Data Integrity Mode to "ECC" in BIOS's SeePU&Chipset Features Setup menu to enable the ECC function. ECC detects double bit errors and detects and corrects single bit memory errors on the fly without user intervention. Errors may be generated by a defective memory module, conflicting memory speeds between different banks, DMA, etc.

Chapter 3

Award BIOS Setup Program

Award's BIOS ROM has a built-in setup program that allows users to modify the basic system configuration. This information is stored in CMOS RAM so that it can retain the setup information, even when the power is turned off.

When you turn on or restart the system, press the Delete key to enter the Award BIOS setup program. The primary screen as shown in Figure 3-1 is a list of the menus and functions available in the setup program. Select the desired item and press enter to make changes. Operating commands are located at the bottom of this and all other BIOS screens. When a field is highlighted, on-line help information is displayed on the left bottom edge of the screen.

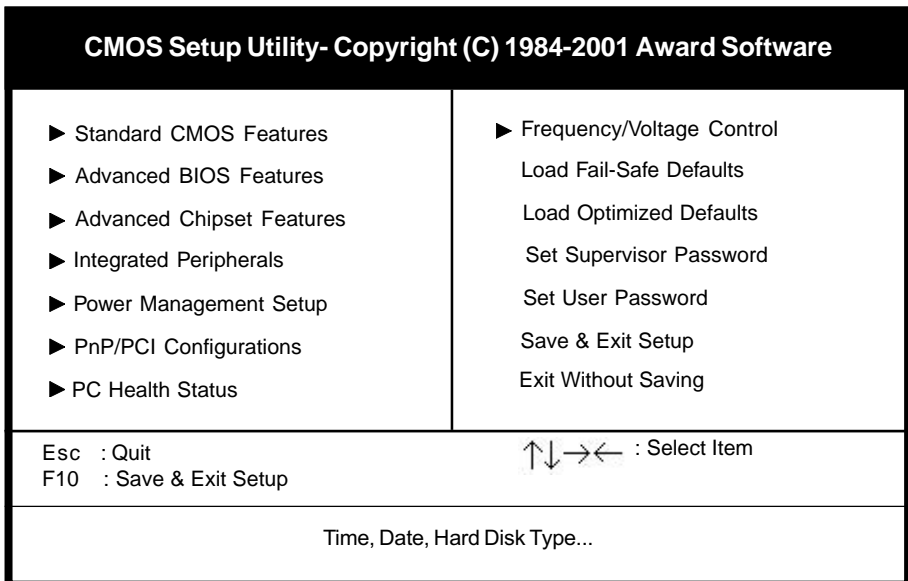

Figure 3-1 Setup Program Initial Screen

3-1 Standard CMOS Setup

The Standard CMOS Setup allows users to configure system components such as hard disk drive, floppy disk drive and video display as well as date, time and boot up error signaling. This configuration menu should be changed when installing a mainboard for the first time, changing hardware in your system such as the HDD, FDD, video display, or when the CMOS data has been lost or contaminated. Choose the Standard CMOS Setup option from the CMOS Setup Utility menu (Figure 3-1) to display the following screen. When a field is highlighted, on-line help information is displayed on the left bottom edge of the screen.

CMOS Setup Utility- Copyright (C) 1984-2001 Award Software		Item Help
Standard CMOS Features		Menu Level ▶
Date (mm : dd : yy)	Thu, Mar 23 2000	
Time (hh : mm : ss)	17 : 14 : 44	
▶ IDE Primary Master	Press Enter None	
▶ IDE Primary Slave	Press Enter None	
▶ IDE Secondary Master	Press Enter None	
▶ IDE Secondary Slave	Press Enter None	
Drive A	1.44M, 3.5 in.	
Drive B	None	
Floppy 3 Mode Support	Disabled	
Video	EGA/VGA	
Halt On	All Errors	
Base Memory	640K	
Extended Memory	65472K	
Total Memory	66496K	

↑↓ → ← :Move Enter:Select +/-/PU/PD:Value F10:Save ESC:Exit F1:General Help
 F5:Previous Values F6:Fail-Safe Defaults F7:Optimized Defaults

Figure 3-2 Standard CMOS Features Screen

Date/Time

Set the date and time. Do not skip this function as all of your timed events such as power management, saving files, etc. are based on this timer.

Hard Disk Setup (Primary/Secondary; Master/Slave)

This category identifies up to four IDE hard disk drives that have been installed in the computer. This section does not show information on other IDE devices such as CD-ROM drives or other hard drive types such as SCSI drives.

Type (Auto/User/None): Use the fields under the Type column to determine the method you will use to configure the IDE devices. If you choose Auto, BIOS will automatically detect and make optimal settings for most IDE hard drives.



The mainboard manufacturer recommends that you choose Auto for all drives.

Choose User to define your own drive type manually. You must enter values indicated in the table below into each drive parameter field. This information should be included in the documentation from your hard disk vendor or system manufacturer:

TYPE	Setting method
CYLS	Number of cylinders
HEAD	Number of heads
PRECOMP	Write precompensation cylinder
LANDZ	Landing zone
SECTOR	Number of sectors
MODE	Mode type

Table 3-1 Hard Disk Drive Parameters

Cyls/Head/Sector: The number of Cylinders, Heads, and Sectors can usually be found written on the top of the hard disk. If you have a relatively new hard drive, entering this information alone is usually sufficient for normal hard disk operation. The hard disk will not work properly if you enter improper information for these categories.

Precomp: Older hard drives (i.e., MFM or RLL drives) have the same number of sectors per track at the innermost tracks as at the outermost tracks. Thus, the data density at the innermost tracks is higher and the bits are lying closer together. Even though the physical size of a sector gets progressively smaller as the track diameter diminishes, each sector must still hold 512 bytes. Write precompensation circuitry compensates for the difference in sector size by boosting the write current for inner track sectors.

Landz: This defines the address of the landing zone and is only used for older hard drives which do not have an auto-parking feature.

Mode: If the Type value is not None for any device, you must set the Mode value for that device. There are four different Mode values: Auto, Normal, Large, and LBA.

Auto - BIOS detects and enters the IDE drive type during boot up.

Normal - for IDE drives that meet the old IDE specification which support a maximum capacity of 528MB (1024 cylinders, 16 heads, and 63 sectors).

Large - for IDE drives that do not support LBA and have more than 1024 cylinders. Try this setting if your hard disk does not operate properly with the LBA setting. Large mode is not supported by all operating systems, i.e., only certain versions of DOS support large mode.

LBA - (Large/Logical Block Addressing) With LBA, the IDE controller transforms the data address described by sector, head, and cylinder number into a physical block address, significantly improving data transfer rates. This mode is for drives with greater than 1024 cylinders and between 528MB and 8.4GB in size. This protocol is the current common standard.

Choose None for Type if there are no IDE HDD devices in your system.

- ☞ You can use the IDE HDD Auto Detection function to auto detect your hard drive parameters. Using this function will automatically insert the parameters discussed under Hard Disk Setup and will indicate User for the Field value. Please see Section 3-9 for more information.

Floppy Disk Drives

Choose the memory capacity and disk size that corresponds with that of your floppy disk drive(s).

Video

Select the type of video adapter present in your system. You can ignore this setting if you are using a VGA monitor since VGA BIOS automatically configures this setting.

Halt

When the system is powered on, BIOS performs a series of diagnosis tests called POST (Power On Self Test). This function stops the computer if BIOS detects a hardware error. You can tell BIOS to halt on all errors, no errors, or not to halt on specific errors.

3-2 Advanced BIOS Features

By choosing the Advanced BIOS Features option from the Standard CMOS Features menu (Figure 3-1), the screen below is displayed. This sample screen contains the manufacturer's default values for the mainboard.

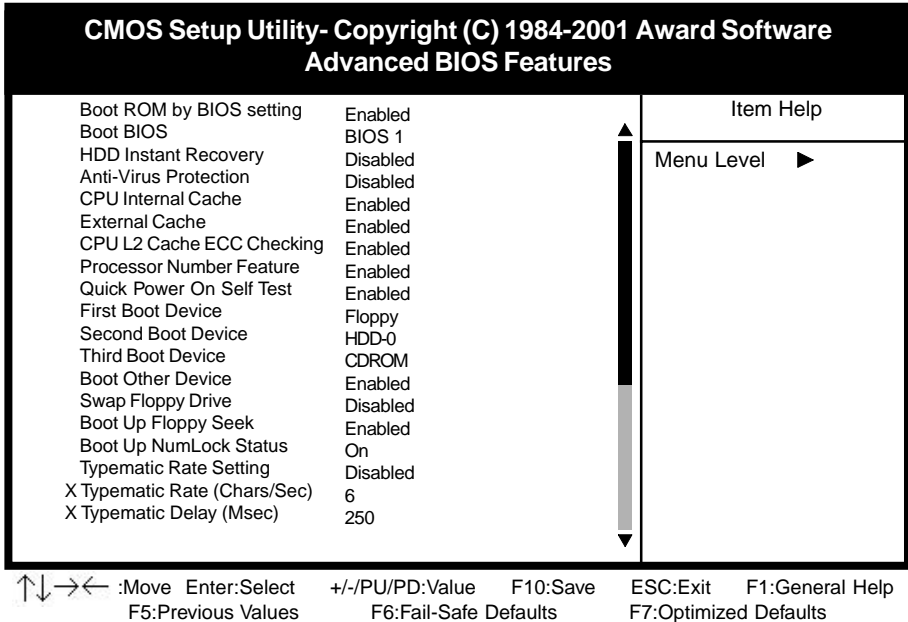

Figure 3-3 Advanced BIOS Features Screen

A. Boot ROM by BIOS Setting(Optional for Twin BIOS)

Enabling this function allows you to choose either BIOS 1(default) or BIOS 2 option to boot your system.

B. HDD Instant Recovery

This board supports HDD Instant Recovery, select enabled to use this function. Upon system boot up, the HDD Instant Recovery Utility will be shown on the screen to let you install this utility. (See Appendix II)

C. Anti-Virus Protection

Trend ChipAway Virus

Trend ChipAway Virus is a code incorporated in the mainboard's BIOS firmware. During the boot-up sequence, BIOS loads before loading of the partition table or boot sector. ChipAway Virus loads with BIOS and is able to detect boot-up viruses before they have a chance to infect the hard drive. ChipAway Virus employs rule-based logic that doesn't look for specific viruses but rather detects patterns found in every virus, eliminating the need to perform periodical version updates after new viruses have been found.

D. Cache Control

CPU Internal Cache/External Cache

Cache memory is much faster than conventional DRAM system memory. These fields allow you to enable or disable the CPUs Level 1 built-in cache and Level 2 external cache. Both settings are left enabled to significantly increase the performance of your computer.

E. Boot Up Features

After turning on the system, BIOS will perform a series of device initialization and diagnostic tests discussed below.

Quick Power On Self Test (POST)

Enable this function to reduce the amount of time required to run the POST (Power On Self Test). BIOS saves time by skipping some items during POST. It is recommended that you disable this setting. Discovering a problem during boot up is better than loosing data during your work.

First/Second/Third/Boot Other Device

This option sets the sequence of drives BIOS attempts to boot from after POST completes. BIOS will search these drives for an operating system.

Swap Floppy Drive

Enabling this function will swap the floppy drive assignment so that drive A will function as drive B, and drive B will function as drive A. Note that the boot sequence assignment mentioned directly above does not include booting from floppy drive B. This function is useful if floppy drives B and A are of a different format and you want to boot from floppy drive B.

Boot up Floppy Seek

During POST, BIOS will determine if the installed floppy disk drive has 40 or 80 tracks. A 360K drive has 40 tracks and 720K, 1.2M and 1.44M drives have 80 tracks. All modern floppy disk drives have 80 tracks.

Boot Up NumLock Status

This function defines the keyboard's number pad as number keys or arrow keys.

F. Keyboard Interface

Typematic Rate Setting

When enabled, you can set the following two typematic control items. When disabled, keystrokes are determined arbitrarily by the keyboard controller in your system.

Typematic Rate (Chars/Sec)

The typematic rate sets the rate at which characters on the screen repeat when a key is pressed and held down.

Typematic Delay (Msec)

The typematic delay sets how long after you press a key that a character begins repeating.

G. Security Option

The Supervisor and/or User Password functions shown in Figure 3-1 must be set to take advantage of this function. See Section 3-11 for password setting information. When the Security Option is set to System, a password must be entered to boot the system or enter the BIOS setup program. When the Security Option is set to Setup, a password is required to enter the BIOS setup program.

H. OS Select (For DRAM >64MB)

If your system's DRAM is larger than 64MB and you are running OS/2, select OS/2 as the item value. Otherwise, set the item value to Non-OS/2 for all other operating systems.

I. Shadow Memory



Software such as system BIOS, video BIOS, SCSI BIOS, etc that resides in ROM (Read Only Memory) chips is called firmware. Shadowing of firmware occurs when BIOS is copied to RAM address C0000h through DFFFFh. Video BIOS loads into the C0000-C7FFF memory area when video shadowing is enabled. If an expansion peripheral in your system contains ROM-based firmware, you need to know the address range the ROM occupies to shadow it into the correct area of RAM.

Shadowing improves the firmware's performance because the firmware can be read by the CPU through the 16- or 32-bit DRAM bus as opposed to the 8-bit XT bus. However, shadowing also results in reducing the amount of high memory (640 KB to 1 MB) for loading device drivers. Shadowing is used mostly for ROM chips on ISA cards and not for PCI cards. Shadowing and playing games at the same time may result in system instability as some games access the RAM memory area being shadowed.

3-3 Advance Chipset Features

By choosing the Advanced Chipset Features option from the Standard CMOS Features menu (Figure 3-1), the screen below is displayed. This sample screen contains the manufacturer's default values for the mainboard.

CMOS Setup Utility- Copyright (C) 1984-2001 Award Software
Advanced Chipset Features

Bank 0/1 DRAM Timing	SDRAM 10ns		Item Help
Bank 2/3 DRAM Timing	SDRAM 10ns		
Bank 4/5 DRAM Timing	SDRAM 10ns		
SDRAM Cycle Length	3		
DRAM Clock	Host CLK		
Memory Hole	Disabled		
P2C/C2P Concurrency	Enabled		
Fast R-W Turn Around	Disabled		
System BIOS Cacheable	Disabled		
Video RAM Cacheable	Disabled		
AGP Aperture Size	64M		
AGP-4X Mode	Disabled		
AGP Comp. Driving	Auto		
X AGP C.Driving Strength	00		
Flash BIOS Protection	Disabled		
Hardware Reset Protect	Disabled		
OnChip Sound	Enabled		
OnChip Modem	Enabled		
Spectrum Spread	Disabled		

 :Move Enter:Select +/-/PU/PD:Value F10:Save ESC:Exit F1:General Help
 F5:Previous Values F6:Fail-Safe Defaults F7:Optimized Defaults

Figure 3-4 Chipset Features Setup Screen



All of the above settings have been determined by the mainboard manufacturer and should not be changed unless you are absolutely sure of what you are doing. Explanation of the DRAM timing and chipset features setup is lengthy, highly technical and beyond the scope of this manual. Below are abbreviated descriptions of the functions in this setup menu. You can look on the world wide web for helpful chipset and RAM configuration information including AWARD's web site at <http://www.award.com>.

A. BANK 0/1, 2/3 & 4/5 DRAM Timing

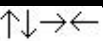
This item allows you to select the value in this field, depending on whether the board has pagd DRAM or EDO (Extended Data Output) DRAMs.

B. SDRAM Cycle Length

When synchronous DRAM is installed, the number of the clock cycles of CAS latency depends on the DRAM timing. Do not reset this setting from the default value specified by the system designer.

C. Memory Hole at 15M-16M

Enabling this function will reserve the memory address space between 15MB and 16MB for ISA expansion cards. However, enabling this function will result in not allowing the system to have access to memory above 16MB. Please note that some expansion cards require this setting to be enabled. The default setting is Disabled. If Auto Configuration is enabled, you must set the DRAM timing function to 60ns or 70ns, depending on the type of DRAM you install.

D. System BIOS Cacheable

Enabling this function allows caching of the system BIOS ROM at F0000h-FFFFFh, resulting in better system performance. However, if any program writes to this memory area, a system error may result. Caching the system BIOS results in better performance than shadowing the system BIOS as discussed in Section 3-2.

E. Video RAM Cacheable

Enabling this function will allow caching of the video RAM, resulting in better system performance. However, if any programs write to this memory area, a system error may occur.

F. AGP Aperture Size

This function determines the amount of system memory that is given to the AGP card. Options range from 4MB to 128MB. This is a dynamic memory allotment in that the AGP card will only use the amount of memory that it needs. The remaining memory not in use will be available for the system to use. For example, if 16MB is allotted to the AGP card and the card only needs 8MB, the remaining 8MB will be available for system use.

G. AGP-4X Mode

Enable this setting to utilize the 4X mode (twice as fast as 2X) offered by advanced AGP cards. Your VGA card must support 4X mode in order to take advantage of the faster speed.

H. Flash BIOS Protection

The mainboard manufacturer developed BIOS protection technology that protects the System BIOS from accidental corruption by unauthorized users or computer viruses. When enabled, the BIOS data cannot be changed when attempting to update BIOS with the the FLASH utility. When disabled, the BIOS data can be updated by using the FLASH utility.

I. Hardware Reset Protect

When this function is enabled, your PC's hardware reset button will not function. This function is especially useful to prevent accidental resets for file servers and routers, etc., which should be available 24 hrs/day. When disabled, your PC's hardware reset button will function normally.

J. OnChip Sound

This function must be enabled in order to use the onboard audio function. To terminate this function set it to disabled.

K. OnChip Modem

This function must be enabled in order to use the soft modem riser card on AMR slot. To terminate this function set it to disabled. Be sure to set AMR/MR Setting jumpers (JP4A/B/C/D) as discussed in Section 2-4 of this manual to enable this function.

L. Spectrum Spread

When Enabled this function will cause lower EMI by spreading the system frequency spectrum. For normal operation, disable this function.

M. Memory Parity/ECC Check

If the DRAM chips in your system support parity/ECC check, select Enabled

3-4 Integrated Peripherals

This section provides information on setting peripheral devices. By choosing the Integrated Peripherals option from the Standard CMOS Features menu (Figure 3-1), the screen below is displayed. This sample screen contains the manufacturer's default values for the mainboard.

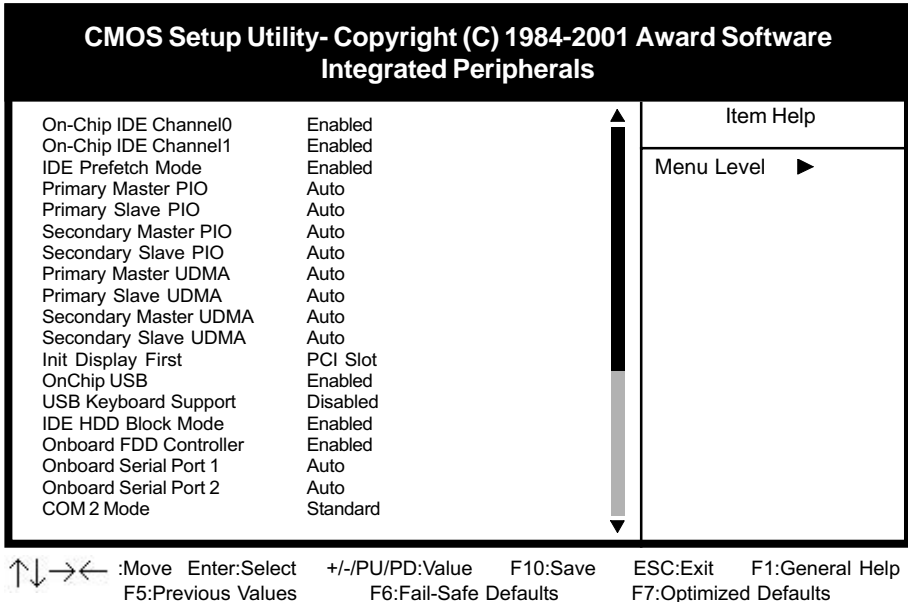

Figure 3-5 Integrated Peripherals Screen

A. On Board IDE Control

On-chip IDE channel 0/1

You can set this to disable the On-chip IDE controller if you are going to add a higher performance IDE board.

IDE Primary/Secondary Master/Slave PIO

The four IDE PIO (programmed Input/Output) fields let you set a PIO mode (0-4) for each IDE device that the internal PCI IDE interface supports. Modes 0 through 4 provide successively increased performance. In Auto mode, the system automatically determines the best mode for each device.

B. Init Display First

This function allows user to choose between AGP slot or VGA slot to initialize Display first .

C. OnChip USB

Enable the on-board Universal Serial Bus (USB) controller if you want to connect a USB keyboard to your system. Note that if this setting is disabled, you can still temporarily use a USB keyboard during bootup so that you can enter BIOS and enable this setting. If you pass the bootup stage without enabling this function, your PS/2 keyboard will no longer work.

D. USB Keyboard Support

Set to Button Only to control the system power via the button on your system case. Set to Mouse Left/Right Click to turn on the power via a PS/2 mouse, and set to Keyboard 98, Hot Key or Password to turn on the power via keyboard. With Hot Key and Password you must decide on which keys will turn on the power.

E. IDE HDD Block Mode

Block mode is also called block transfer, multiple commands, or multiple sector read/write. If your IDE hard drive supports block mode (most new drives do), select Enabled for automatic detection of the optimal number of block read/writes per sector the drive can support.

F. Onboard FDC Controller

Select Enabled if your system has a floppy disk controller (FDC) installed on the system board and you wish to use it. If you install an add-in FDC or the system has no floppy drive, select Disabled in this field.

G. COM2 Mode Select

This function allows you to select an operating mode for the second serial port. (Normal RS-232C serial port/IrDA SIR 1.0 specification/ASKIR 0.57-MB/sec infrared port)

H. Onboard Parallel Port

Select a logical LPT port address and corresponding interrupt for the physical parallel port.

I. Parallel Port Mode

Select an operating mode for the onboard parallel (printer) port. Select SPP unless you are certain your hardware and software support one of the other available modes.

3-5 Power Management Setup

This section provides information on the Green PC power management functions. By choosing the Power Management Setup option from the Standard CMOS Features menu (Figure 3-1), the screen below is displayed. This sample screen contains the manufacturer's default values for the mainboard

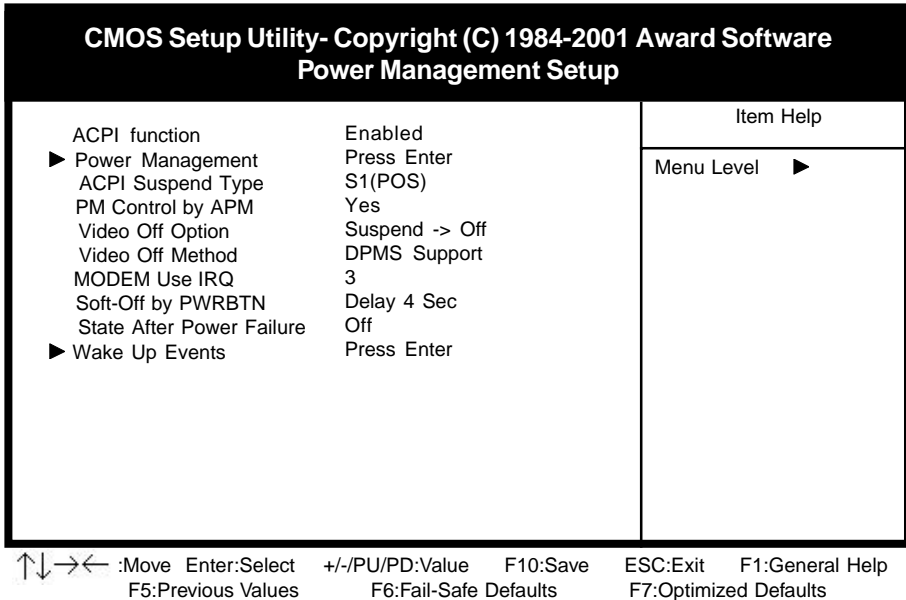

Figure 3-6 Power Management Setup Screen

A. Advanced Configuration Power Interface (ACPI)

ACPI management enables the operating system to control the amount of power given to each device attached to the computer. With ACPI, the operating system can turn off peripheral devices, such as CD-ROM players, when they are not in use.

B. Power Management

Power management allows the computer to save electricity when it is not in use by entering increasingly deep power saving modes as shown by the diagram below.

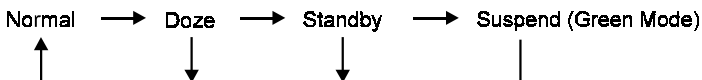

Figure 3-7 Power Saving Mode Flow Chart

C. Video Off Option

This setting allow you to selects the power-saving modes during which the monitor goes blank:

D. Video Off Method

This function serves as both a screen saver and power saver for monitors. See the next function, Video Off After, for setting the video timer.

Blank - BIOS will only blank the monitor's screen. The electricity saved in this mode is negligible and this function is only used as a screen saver to prevent screen damage while the screen is on but not in use.

V/H SYNC+Blank - The system turns off the vertical and horizontal synchronization ports, writes blanks to the VGA buffer and the monitor's electron gun turns off. This function requires a monitor with Green features in order to take advantage of the power saving function. If you enable this function and do not have a Green monitor, the result will be the same as if you had selected Blank. This function serves as both a screen saver and an electricity saver.

DPMS Supported - Select this option if your video card supports the Display Power Management Signaling (DPMS) standard (i.e., you have a monitor that supports Green features). Use software supplied by your video subsystem to set video power management options.

E. Modem Use IRQ

If your computer has an modem, use this function to tell BIOS which IRQ is being occupied by the modem card. When the system is in Green mode, the modem requires an IRQ assignment to wake up the system and perform tasks. This assignment is compliant with the APM 1.2 specification and is to be used in coordination with APM 1.2 compliant operating systems.

F. Soft-Off by PWR-BTTN

When set to Delay 4 Sec., this function allows the power button to put the system in Suspend, a power saving mode. See Section 2-4 for operation instructions of the override power button operation which puts the system in Suspend mode. When set to Instant-Off the Soft-Off by PWR-BTTN function is disabled and the computer turns completely off when the power button is pressed.

H. Power On By PCI Card

Enable this selection to use the Power on by PCI card function.

I. Power On By Modem/LAN

When enabled, a modem/LAN that receives a signal will wake up the system from soft off and green mode. You should connect the modem to the COM port and turn on the resume event in green mode.

J. Power On By Alarm

When enabled, this setting allows the system to turn back on at a designated time of the month. User must designate date of month and time of day. This function is only available when using an ATX power supply and the Software Power-Off function to turn off the computer. See the Software Power-Off feature in Section 2-4 of this manual for instructions.

3-6 PNP/PCI Configuration

This section provides IRQ and DMA setting information. By choosing the PNP/PCI Configuration option from the Standard CMOS Features menu (Figure 3-1), the screen below is displayed. This sample screen contains the manufacturer's default values for the mainboard.

CMOS Setup Utility- Copyright (C) 1984-2001 Award Software		Item Help
PnP/PCI Configurations		Menu Level ▶
PNP OS Installed	No	
Reset Configuration Data	Disabled	
Resources Controlled By	Auto(ESCD)	
X IRQ Resources	Press Enter	
X DMA- Resources	Press Enter	
PCI/VGA Palette Snoop	Disabled	
Assign IRQ For VGA	Enabled	
Assign IRQ For USB	Enabled	
Raid Card Boot First	Disabled	
Slot 1 Use IRQ No.	Auto	
Slot 2/5 Use IRQ No.	Auto	
Slot 3 Use IRQ No.	Auto	
Slot 4 Use IRQ No.	Auto	
FDD IRQ Can Be Free	Yes	

↑↓→← :Move Enter:Select +/-/PU/PD:Value F10:Save ESC:Exit F1:General Help
 F5:Previous Values F6:Fail-Safe Defaults F7:Optimized Defaults

Figure 3-7 PnP/PCI Configurations Screen

A. PNP OS Installed

If you want to install a PNP compatible OS(such as Windows 95) set to Yes.

B. Resources Controlled By

When set to Manual the system BIOS will not refer to the ESCD for IRQ & DMA information. Instead, it will refer to the items in the setup menu for assigning IRQ & DMA. When set to Auto the system BIOS will refer to the ESCD for all legacy information.

C. RAID Card Boot First (optional)

If additional SCSI(RAID) card installed on PCI slot and this feature is set to enabled. The BIOS scan from the highest PCI bus number to boot up. If set disabled BIOS scan from the lowest PCI bus number to boot up.

D. FDD IRQ Can Be Free

This function allows user to choose if the FDD IRQ is able to be freed up. The default setting is Yes and this does not allow the IRQ to be free.

3-7 PC Health Status

By choosing the PC Health Status option from the Standard CMOS Features menu (Figure 3-1), the screen below is displayed. This sample screen contains the manufacturer's default values for the mainboard.

CMOS Setup Utility- Copyright (C) 1984-2001 Award Software		Item Help
PC Health Status		Menu Level ▶
Current CPU Temp.	36° C/96° F	
Current System Temp.	31 °C/87 °F	
Current CPU FAN Speed	3500 RPM	
Current SYS FAN Speed	3500 RPM	
Vcore	1.8V	
2.5V	2.48V	
3.3V	3.32V	
5 V	5.05V	
12 V	12.16V	

↑↓→← :Move Enter:Select +/-:PU/PD:Value F10:Save ESC:Exit F1:General Help
 F5:Previous Values F6:Fail-Safe Defaults F7:Optimized Defaults

Figure 3-8 PC Health Status Screen

A. CPU Warning Temperature

Set a limit for the CPU temperature. If the CPU temperature extends beyond the limit, any warning mechanism programmed into your system will be activated.

3-8 Frequency/Voltage Control

By choosing the **Frequency/Voltage Control** Setup option from the Standard CMOS Features menu (Figure 3-1), the screen below is displayed. This sample screen contains the manufacturer's default values for the mainboard.

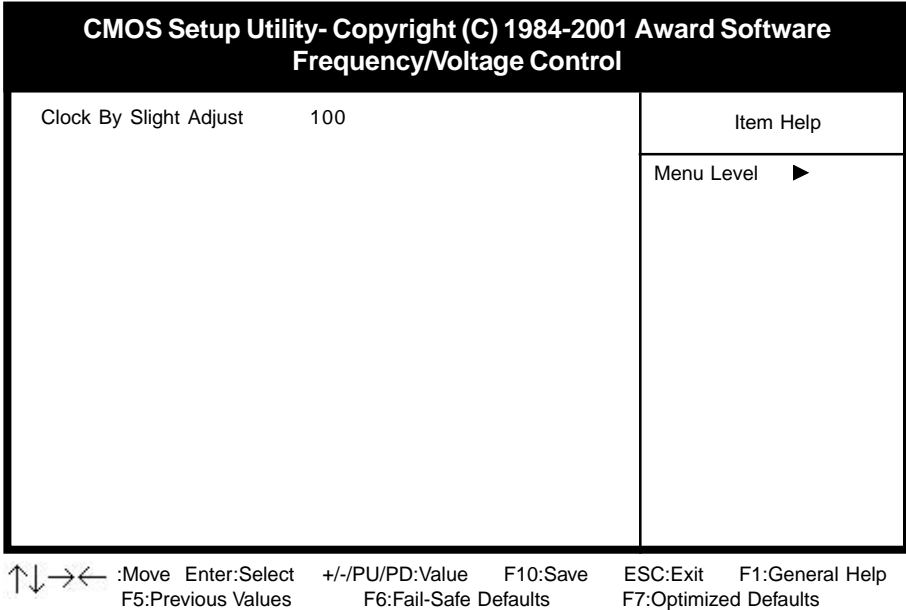

Figure 3-9 SeePU Setup Screen

A. CPU BUS Frequency

The CPU BUS frequency allows you to easily select your CPU's **external clock frequency** in BIOS. Refer to Section 2-3 for details.

3-9 Load Fail-Safe Defaults

Load Fail-Safe Defaults loads the default BIOS values directly from the Standard CMOS Features menu (Figure3-1). If the stored record created by the setup program becomes corrupted and therefore unusable, these defaults will be loaded automatically when you turn on the computer.

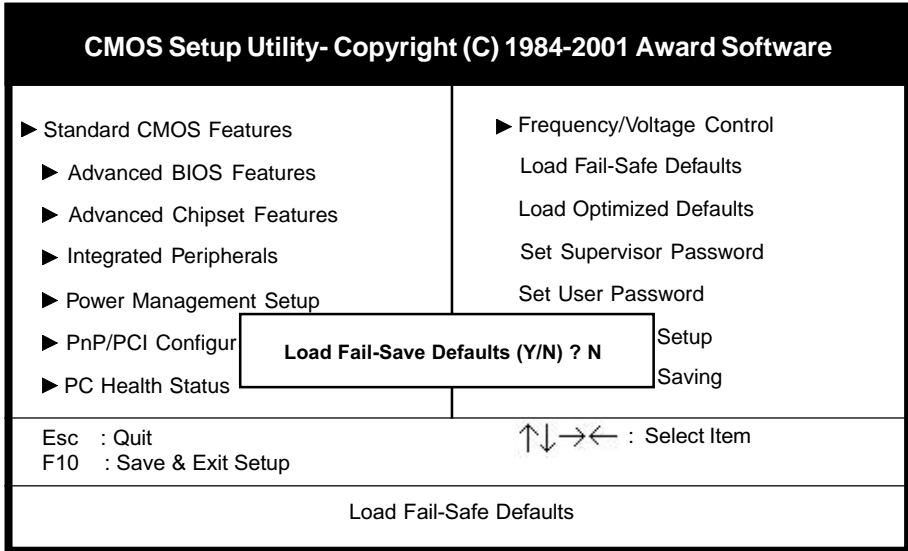

Figure 3-10 Load Fail-Safe Defaults Screen

3-10 Load Optimized Defaults

Load Optimized Defaults loads the default system values directly from the Standard CMOS Features menu (Figure3-1). If the stored record created by the setup program becomes corrupted and therefore unusable, these defaults will be loaded automatically when you turn on the computer.

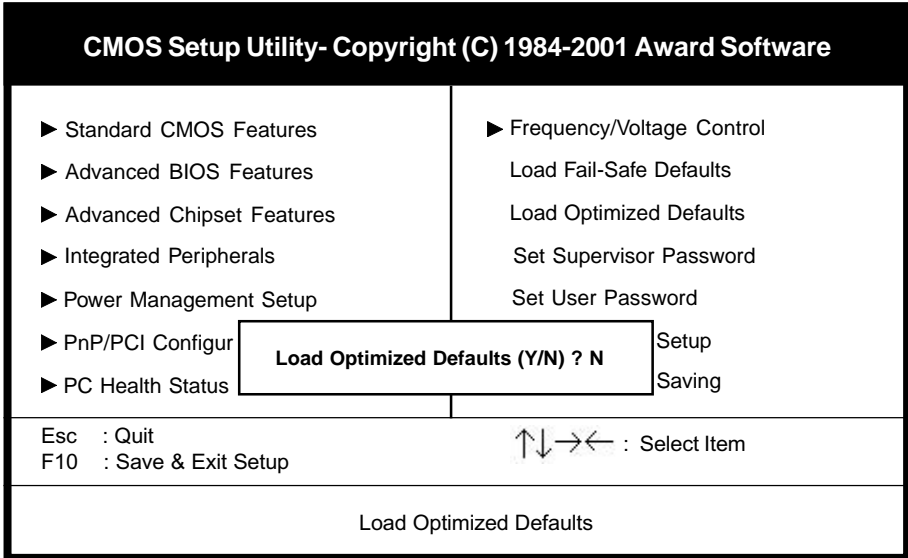

Figure 3-11 Load Optimized Defaults Screen

3-11 Supervisor Password & User Password Setting

There are four different variables that control password settings. The first two are located under the Security Option function in BIOS Features Setup Menu (Figure 3-1). When the Security Option function is set to Setup, a password is required to enter BIOS and change BIOS settings. When the Security Option function is set to System, a password is required to enter both BIOS and the computer's operating system (for example Windows 95) found on the boot drive. This is shown in Figures 3-12 and 3-13.

The third and fourth variables are user password and supervisor password selected in BIOS (Figure 3-1). The main purpose of separating user and supervisor is to allow only the supervisor to have control over the settings in BIOS. The user, on the other hand, is only allowed to access the computer's operating system and change the user password in BIOS (See Figure 3-13). Note that when there is no supervisor password set, the user password controls access to all BIOS settings (See Figure 3-12 below).

A. Set Either Supervisor Password or User Password

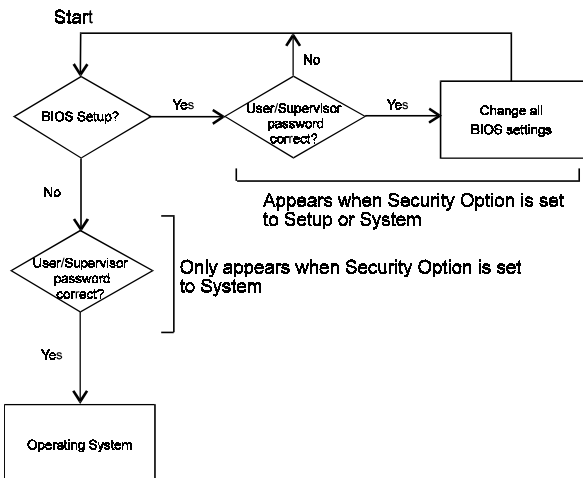

Figure 3-12 Set Either Supervisor or User Password

B. Set Both Supervisor Password and User Password

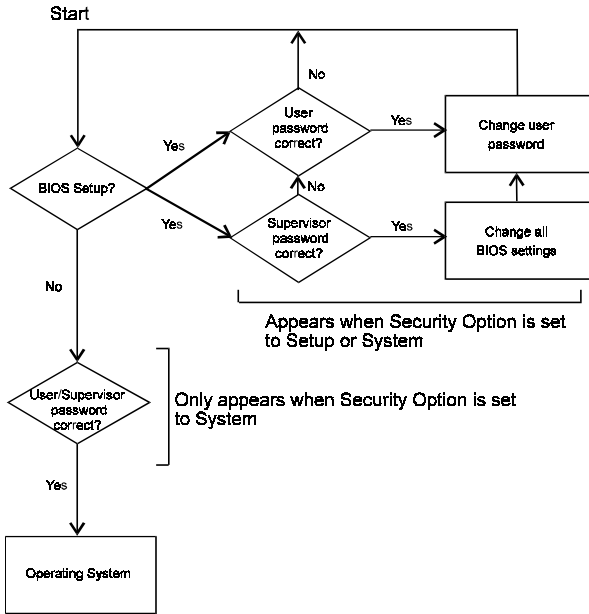

Figure 3-13 Set Both Supervisor and User Password

3-12 Save and Exit Setup

If you select this and type Y (for yes) followed by the [Enter] key, the values entered in the setup utilities will be recorded in the CMOS memory of the BIOS chip.

3-13 Exit Without Saving

Selecting this option and pressing Y followed by the [Enter] key lets you exit the Setup program without recording any new values or changing old ones.

Chapter 4

Brief Software Driver Guide

The Mainboard Software Guide is found on the CD-ROM that is enclosed with your mainboard and is a PDF file which must be viewed with Adobe's freeware called Acrobat® Reader. The Acrobat Reader software is also included on the same CD-ROM. See the Readme.txt file in the CD-ROM's root directory for installation instructions of the Acrobat Reader. The Mainboard software guide discusses the following items:

The following items are discussed in the TXT or PDF files:

- VIA Service Pack for Win9x/WinNT including Bus Master IDE drivers, AGP VxD IRQ routing mini port driver and etc.
- Updating Your System BIOS
- Installing and Using a Desktop Management Interface (DMI) Utility for DOS
- Optional C-Media drivers and utility for Win95/98/NT
- Optional IDE RAID0/1 driver for Win98, NT, Win2000



The DMI utility is a DOS utility, operating under Windows or other operating system might cause damage to the BIOS.

Memo

Appendix I

On Board I/O Addresses & IRQ Maps

System Resource	IRQ	I/O Address
1. Timer	IRQ0	040, 043
2. Keyboard	IRQ1	060, 064
3. Programmable INT	IRQ2	0020, 0021, 00A0, 00A1
4. COM2(B)	IRQ3	2F8, 2FF
5. COM1(A)	IRQ4	3F8, 3FF
6. Floppy	IRQ6	3F0, 3F7
7. LPT1	IRQ7	378, 37F
8. Real Time Clock	IRQ8	070, 071
9. PS/2 Mouse	IRQ12	060, 064
10. Math coprocessor	IRQ13	0F0, 0FF
11. IDE 1	IRQ14	1F0, 1F7
12. IDE 2	IRQ15	170, 177

✎ **IRQ 5, 9, 10 and 11 are available for interface cards.**

Memo

Embedded Flash Utility

This mainboard is equipped with an Erasable Flash ROM and an Embedded Flash Utility which allows the user to update the BIOS to a newer version. Embedded Flash Utility eases BIOS upgrade and eliminate the compatibility issue between different Flash ROM type and version of Flash utility.

Update Your System BIOS

1. Start computer, upon post, press ALT+F2 Keys to enter AWDFLASH setup.
2. Insert the floppy disk with the latest BIOS file into the floppy drive A(or B) and then press Enter to start programming.

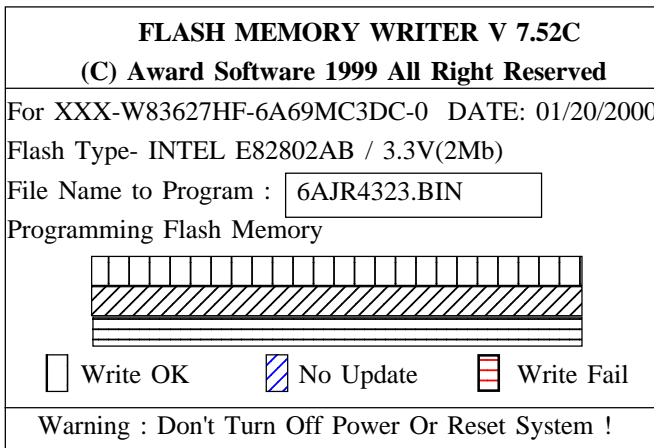

Sample of Programing Flash Memory Screen

3. When finished, the system will automatically Restart.

Note:

- ✎ Flash BIOS Protection must be set to Disabled in the Advance Chipset Feature from the CMOS Setup Utility menu. See Chapter 3.
- ✎ Don't turn off or restart your system during programming process.
- ✎ Make sure that your floppy diskette have only one BIN file to avoid confusion.

Memo

HDD Instant Recovery Utility

This mainboard is equipped with HDD Instant Recovery utility embedded in the BIOS ROM. The feature is an option which allows the user to install or not. HDD Instant Recovery utility is a Pre-O.S. backup technology that provides backup before any OS is being activated. Just one press on the Hotkey, HDD Instant Recovery can revive your system even if your O.S. crashed or not working properly.

❑ HDD Instant Recovery Concept

HDD IR will save your vital O.S. and application software in a hidden space inside the same hard drive. Since the backup file occupies some space in the hidden directory, the displayed disk space will be reduced. HDD IR will backup your system either with the Smart or Equivalent Backup depends on your O.S. type.

Smart Backup (FAT16/32 format i.e. Win 95/98 O.S.)

- Backup space is the actual system space used.

Equivalent Backup (NTFS format i.e. Windows 2000/NT.)

- Backup space equivalent to the drive space where the O.S. located.

❑ Utility Installation

1. Enable the HDD Instant Recovery in the BIOS Features setup from the CMOS Setup Utility menu. Save and exit to reboot.
2. Upon system boot up, the HDD Instant Recovery Utility will be shown on the screen. Selet **Install** and press Enter key to read the instruction.
3. Press **F8** key to continue, you will be prompt to confirmed to keep original data.
4. Type **Y** and press Enter and wait for the installation process to finish and the system will automatically reboot.

HDD Instant Recovery Utility

<Alt-F1>: Backup System

<Alt-F2>: Disk Information

<Alt-F3>: Restore System

<Alt-F4>: Hard Disk Copy

<Alt-F5>: Uninstall

HDD Instant Recovery Utility Setup screen

□ Backup System

Smart Backup

1. Upon system boot up, the HDD Instant Recovery Utility will be shown on the screen. Selet Backup System by pressing **Alt+F1** key.
2. Select your hard drive to backup.
3. Wait for the backup process to finish and the system will automatically reboot.

Equivalent Backup

 Still under evaluation testing for future Windows 2000/NT supports.

□ Disk Information

1. Upon system boot up, the HDD Instant Recovery Utility will be shown on the screen. Select Disk Information by pressing **Alt+F2** key to view Disk Info.

□ Hard Disk Copy

1. Upon system boot up, the HDD Instant Recovery Utility will be shown on the screen. Selet Hard Disk Copy by pressing **Alt+F4** key.
2. Select which hard drive to backup.(Copy 1 to 2 or 2 to 1 or 1 to 2 3 4)
3. Wait for the hard disk copy process to finish and the system will auto reboot.

□ Restore System

1. Upon system boot up, the HDD Instant Recovery Utility will be shown on the screen. Selet Restore System by pressing **Alt+F3** key.
2. You will be prompt to confirmed restore drive. Type **Y** and press **Enter** key.
3. Wait for the backup process to finish and the system will automatically reboot.

□ Uninstall

1. Upon system boot up, the HDD Instant Recovery Utility will be shown on the screen. Seletc uninstall by pressing **Alt+F5** key.
2. You will be prompt to confirmed uninstall. Type **Y** and press **Enter** key.
3. Wait for the uninstalling process to finish and press any key to reboot



This function does not support Multi-Booting management utility like System Commander, etc.



Always uninstall this function before you format or partition the hard disk for other usage.

TwinBIOS Technology (Optional) Introduction

We are pleased to introduce the Peer to Peer **TwinBIOS** technology, a new generation BIOS system for your motherboard. Twin BIOS are physically two BIOS chips, known as BIOS 1 and BIOS 2. If either one of the BIOS fails, the other BIOS will be ready to take over the Boot BIOS function. Whether the problem is caused by a virus, flashing BIOS failure or a corrupted Boot BIOS chip, The other BIOS will always back you up.

❑ Using the Backup BIOS Recovery

This feature enable you to manually shift to another BIOS once the the BIOS fails to boot. Set (JPX1) jumper pin to 2-3 and then press the reset button together with the power on button to boot up.

❑ Selecting Boot BIOS

Set (JPX1) jumper pin to 1-2 to enable BIOS selection in the Advance BIOS Features setup from the CMOS Setup Utility menu. Select Boot BIOS and choose between BIOS 1 (default) or BIOS 2 option to boot your system.

❑ Update BIOS Using Embbeded Flash Memory Utility

A. Boot from BIOS 1

1. Start computer, upon post, press ALT+F2 Keys to enter AWDFLASH setup.

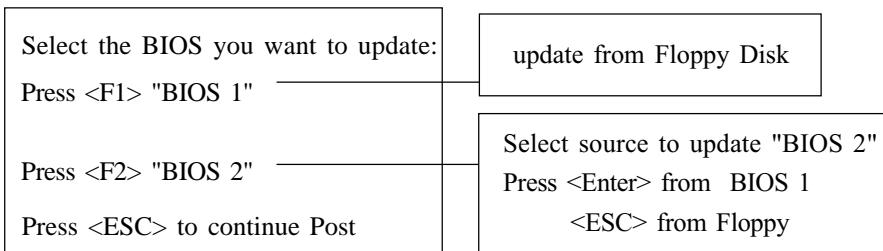

Note:

- ✎ Flash BIOS Protection must be set to Disabled in the Advance Chipset Feature from the CMOS Setup Utility menu. See Chapter 3.
- ✎ Don't turn off or restart your system during programming process.

B. Boot from BIOS 2

1. Start computer, upon post, press ALT+F2 Keys to enter AWDFLASH setup.

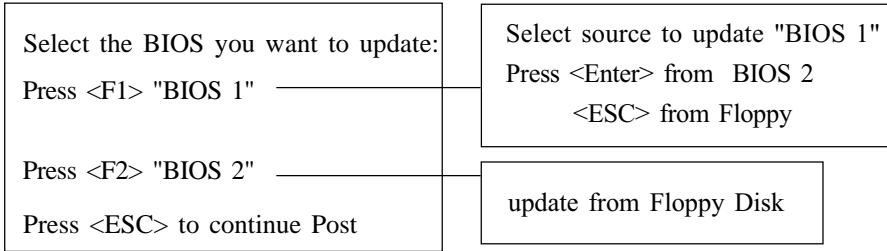

Note:

- ✎ Flash BIOS Protection must be set to Disabled in the Advance Chipset Feature from the CMOS Setup Utility menu. See Chapter 3.
- ✎ Don't turn off or restart your system during programming process.

IDE RAID Technology (Optional)

We are pleased to introduce the High Point **IDE RAID** technology. Though IDE RAID technology has been circling the industry before, we have made it a reality for desktops, workstations, and entry-level server manufacturers.

□ IDE RAID

In a standard PC, each hard drive is seen as an independent disk designated by letters like C, D, E, etc... In a RAID system, multiple hard drives are placed into one or more arrays of disks. Each array is seen as an independent disk, though that array may include upwards of two, three, four, or more drives. This is why RAID stands for Redundant Array of Independent Disks. In an IDE RAID array, of course, the drives are low-cost IDE.

□ Features

Striping

RAID 0 basically links each drive in the array as one huge drive. Storage capacity is determined by the smallest drive in the array. That capacity is then applied to format all other drives in the array. If using a 4GB, 6GB, 5GB drive in a RAID 0 array, your system will see one huge drive of 12GB (4GB x 3) versus 15GB. RAID 0 offers double or more performance under sustained data transfers when one drive per IDE port is used. In such a configuration, unlike SCSI, IDE drives are always available to the system. SCSI requires more management of the SCSI bus.

Mirroring

RAID 1 makes and maintains an identical image of data from one drive to a second drive or from multiple drives to a second set of multiple drives. Should one drive fail, the working drive or drive set continues operation. To the system, such an array is still seen as a single drive letter. While RAID 1 is the least efficient use of hard drives to provide data protection (since the user does not see any of the additional storage capacity of the mirrored drives), low-cost IDE makes it acceptable. If performing 1-to-1 mirroring with two 4GB drives, the system only sees one 4GB drive. IDE RAID 1 represents a significantly lower cost than SCSI RAID 1.

RAID 0+1(Stripe/Mirror)

RAID 0+1 level to provide your system with both double data security and double storage performance. Stripes multiple drives and mirrors to a second striped set of drives for faster performance and fault tolerance.

Memo

CMedia 8738 Audio Subsystem

The CMedia 8738 offers a new generation PCI audio solution: it utilizes the state-of-the-art CRL® 3D Audio technology (HRTF 3D positional audio), and supports Microsoft® Direct Sound®3D and Aureal®'s A3D® interfaces. Better yet, it supports two/four/six speakers and DLS based (Down Loadable Sound) wave table music synthesizer which supports the Direct Music®.

Feature

- Advanced 64-voice wavetable synthesizer
- Programmable independent sample rate from 4KHz to 48KHz for record and playback
- Full-duplex operation for simultaneous recording and playback
- Supports MS DLS (Downloadable sample) level-1 technology with limitless variety of instrument samples using PC RAM
- Supports HRTF 3D positional audio with MSDS, DS3D, DirectMusic, Aureal A3D and Creative EAX (Environment Audio Extensions), C3DX APIs
- 4 or 6-Channel speaker audio support for Home Theater environment
- Supports Fiber Optic module for Internet music, PC, and MD connections
- Supports MIDI and dual game ports
- Embedded 32OHM .5w earphone amplifier

Multi Speakers System

The CMedia 8738 Audio subsystem provides 3 wave channels (front/rear/center+bass), known as the multi speakers system (4 or 6 channel option). When games or application programs via DirectSoundR 3D or A3DR interface locate the sound sources to the listener's back, the two rear speakers will work to enhance the rear audio positional effect, so as to complement the insufficiency of using only two front speakers to emulate the audio effect. The following is the hardware installation and the software setups:

Installation

1. Connect the front pair speakers to the Line-out jack of the audio adapter, and then connect rear pair speakers to Line-in/Rear jack of the audio adapter. The original Line-in can be moved to Aux-in.
2. Install the audio driver and Audio Rack application software(see chapter 4).
3. There is a multi speakers option in the volume control of the mixer, and when you enable this option, it means the rear speakers are connected to Line-in/Rear jack. When Line-in/Rear jack is connected to other external Line-in sources, please **DO NOT** enable this option in order to avoid hardware conflicts. Regarding rear speaker option, you can turn **ON** or turn **OFF** the output of the back speakers, and adjust the volume, to have the rear/front speakers have the same volume.

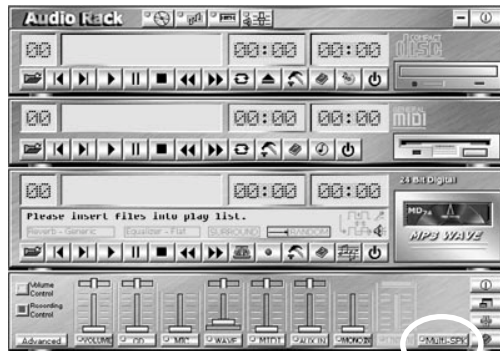

Multi Speaker selector Button

Note: You can test your multi-channel system by clicking the Multi-Channel Audio Demo at C:\WINDOWS\Start Menu\Programs\PCI Audio Application\Multi-Channel Audio Demo(as shown in figure below).

