



Declaration of Conformity

According to 47 CFR, Parts 2 and 15 of the FCC Rules

The following designated product:

EQUIPMENT: MAINBOARD

MODEL NO. : 6AIV

is a Class B digital device that complies with 47 CFR Parts 2 and 15 of the FCC Rules. Operation is subject to the following two conditions:

1. This device may not cause harmful interference.
2. This device must accept any interference received, including interference that may cause undesired operation.

This declaration is given to the manufacturer:

CHAINTECH-EXCEL COMPUTER INC.

4427 Enterprise St. Fremont, CA 94538, U.S.A.

<http://www.chaintech-excel.com>

Chaintech President: Simon Ho

Signature:

A handwritten signature in black ink, appearing to be 'Simon Ho', written over a horizontal line.



Federal Communications Commission Statement

This device complies with FCC Rules Part 15. Operation is subject to the following two conditions:

- ♦ This device may not cause harmful interference
- ♦ This device must accept any interference received, including interference that may cause undesired operation.

This equipment has been tested and found to comply with the limits for a Class B digital device, pursuant to Part 15 of the FCC Rules. These limits are designed to provide reasonable protection against harmful interference in a residential installation. This equipment generates, uses and can radiate radio frequency energy. If this equipment is not installed and used in accordance with the manufacturer's instructions, it may cause harmful interference to radio communications. However, there is no guarantee that interference will not occur in a particular installation. If this equipment does cause harmful interference to radio or television reception, which can be determined by turning the equipment off and on, the user is encouraged to try to correct the interference by one or more of the following measures:

- ♦ Reorient or relocate the receiving antenna.
- ♦ Increase the separation between the equipment and receiver.
- ♦ Connect the equipment to an outlet on a circuit different from that to which the receiver is connected.
- ♦ Consult the dealer or an experienced radio/TV technician for help.

The use of shielded cables for connection of the monitor to the graphics card is required to assure compliance with FCC regulations. Changes or modifications to this unit not expressly approved by the party responsible for compliance could void the user's authority to operate this equipment.

Canadian Department of Communications Statement

This digital apparatus does not exceed the Class B limits for audio noise emissions from digital apparatuses set out in the Radio Interference Regulations of the Canadian Department of Communications.

Manufacturer's Disclaimer Statement

The information in this document is subject to change without notice and does not represent a commitment on the part of the vendor. No warranty or representation, either expressed or implied, is made with respect to the quality, accuracy or fitness for any particular purpose of this document. The manufacturer reserves the right to make changes to the content of this document and/or the products associated with it at any time without obligation to notify any person or organization of such changes. In no event will the manufacturer be liable for direct, indirect, special, incidental or consequential damages arising out of the use or inability to use this product or documentation, even if advised of the possibility of such damages. This document contains materials protected by copyright. All rights are reserved. No part of this manual may be reproduced or transmitted in any form, by any means or for any purpose without expressed written consent of its authors. Product names appearing in this document are mentioned for identification purposes only. All trademarks, product names or brand names appearing in this document are registered property of their respective owners.

Printed in Taiwan

May 2001
100% POST-CONSUMER
RECYCLED PAPER 

Table of Contents

Chapter 1 Introduction	1
1-1 Product Specifications	1
1-2 Package Contents	4
1-3 Mainboard Layout	5
1-4 Connector and Jumper Reference Chart	6
Chapter 2 Hardware Setup	7
2-1 Introduction to Jumpers	7
2-2 Installing a CPU in a Socket 370	8
2-3 CPU Jumper Configuration.....	8
2-4 Connector and Jumper Settings.....	8
2-5 Main Memory Configuration	19
Chapter 3 Award BIOS Setup Program	21
3-1 Standard CMOS Setup	22
3-2 Advanced BIOS Features Setup	25
3-3 Advanced Chipset Setup	28
3-4 Integrated Peripherals	31
3-5 Power Management Setup	34
3-6 PnP/PCI Configuration	37
3-7 PC Health Status.....	38
3-8 Frequency/Voltage Control	39
3-9 Load Fail-Safe Defaults	40
3-10 Load Optimized Defaults	41
3-11 Supervisor Password & User Password Setting	42
3-12 Save and Exit Setup	43
3-13 Exit Without Saving.....	43
Chapter 4 Brief Software Driver Guide	45
Feature Explanations	
Software Power-off Control	10
Over-ride Power Button.....	11
Blinking LED in Suspend Mode	11
Power On By Modem	10/36
Power On By Alarm	36
Poly-fuse Over Current Protection	12
Wake Up On LAN	15
Appendices	
Appendix I On Board I/O Addresses & IRQ Maps	47
Appendix II Embedded Flash Utility	49
Appendix III HDD Instant Recovery utility	51

Chapter 1

Introduction

1-1 Product Specifications

□ Processor

- Supports Intel Socket 370 processors
- System clock 66/100/133MHz

□ Chipset

- VIA PLE133 + VT8231 dual chip AGPset

□ DRAM Memory

- Two 168-pin DIMM sockets support up to 1GB for SDRAM
- Supports PC100/PC-133 SDRAM

□ Expansion Slots

- Three 32-bit PCI slots (Rev 2.2 compliant)
- One ACR slot for ACR card with modem and LAN function
- One CNR slot

□ Boot-Block Flash ROM

- Award System BIOS, supports PnP, APM, DMI, **ACPI** & Multi-device booting features i.e. floppy, LS120, CD-ROM, HDD(IDE, SCSI), ZIP-ATAPI etc.
- Includes Trend **ChipAway Virus** protection for virus-free boot and virus free operating system
 - ✎ Trend ChipAway Virus is a rule-based anti-virus technology and does not require periodical updates of virus code

□ Embedded Ultra DMA-66/100 PCI IDE controller

- Supports two IDE ports up to 4 ATAPI devices
- Supports up to PIO Mode 4 up to 16.6MBps, Multi Mode 4 up to 66MBps and Multi Word Mode 5 up to 100MBps with bus mastering
- Bus Mastering software drivers for common multi-task operating systems

□ Onboard Ultra I/O

- Three UARTs support serial port and IR function
- One parallel supports SPP/ECP/EPP
- One floppy disk drive connector supports up to 2.88MB

❑ **Double Stack Back-Panel I/O Connectors**

- *PS/2 Mini-DIN keyboard and mouse port*
- *Two USB ports*
- *One 9-pin D-SUB male Serial port*
- *One 15-pin D-SUB female VGA port*
- *One 25-pin D-SUB female Printer port*
- *Audio Line-in/out and Mic-in jacks*
- *One 15-pin D-SUB female Game/MIDI port*

❑ **Embedded Audio Subsystem AC-link**

- *Full-duplex operation for simultaneous recording and playback*
- *Built-in FM-emulation music synthesizer*
- *External high quality AC97 CODEC provides 90dB+SNR CD quality audio*
- *Use wavetable data on the system memory*
- *Hardware SoundBlaster Pro for Windows DOS box and real-mode DOS legacy compatibility*
- *Complete software driver support for Win95/98/2000*

❑ **Integrated Trident Blade3D AGP Graphics Engine**

- *64-bit Single Cycle 2D/3D Graphics Engine*
- *Supports 2 to 8 Mbytes of Frame Buffer*
- *Real Time DVD MPEG-2 and AC-3 Playback*
- *Video Processor*
- *Integrated 24-bit 230MHz True Color DAC*

❑ **Embedded System Monitor Hardware**

- *5 external voltage inputs (internal detecting)*
- *1 temperature sensor with thermistor for CPU*
- *2 Fan speed (CPU and System) monitoring with CPU Fan ON/OFF control in suspend*

❑ **Embedded USB Controller**

- *UHCI compliant USB host controller with Root Hub*
- *Four USB ports (UHCI v1.0 compliant)*
- *Optional USB riser with additional 2 USB ports*

❑ **Board Dimensions**

- *Micro-ATX form factor, 244mm x 194mm, 4 Layers*

□ Advanced Management Features

- *Poly-fuse protection for USB and keyboard circuitry*
- *Complete Data Security:*
 - * **Flash BIOS write protection** against unauthorized access
 - * **Trend ChipAway Virus** for a 100% virus free system boot-up
 - * **Embedded Flash Utility** to ease BIOS upgrade and eliminate in compatibility with the flash utility version.
- *Advanced Management Features:*
 - * *Power-on events:*
 - WOL(Wake-on-LAN) network card, Modem ring, RTC Alarm*
 - * *Software power-off control for Win9x*
 - * *Over-ride power button*
 - * *Three states advanced Power-failure recovery: Always On, Always Off, Last state*
 - * *Over-ride power button*
 - * *Blinking Power-LED in suspend*

□ Switching Power Supply Requirement

Output Voltage	Max. Regulation Requirement	Min. Current Requirement (Amps)
+12V	+/- 5%	5.5
+5V	+/- 5%	20
+3.3V	+/- 5%	15
-5V	+/- 10%	0.5
-12V	+/- 10%	0.5
+5VSB	+/- 5%	0.75

Table 1-1



3.3V at 15Amps is necessary too guarantee full loading operation because some AGP cards and memory modules have high current consumption.

1-2 Package Contents

This product comes with the following components:

- One mainboard
- One 40-pin (80-wire) UDMA-66/100 IDE connector ribbon cable (Figure 1-1)
 - * **Color coded connection for UDMA-66/100 cable**
Blue to mainboard, Gray to Master and Black to slave
- One 34-pin floppy disk drive ribbon cable (Figure 1-2)
- One User's Manual
- One CD-ROM that includes
 - Award Flash Utility
 - Award DMI Utility for DOS
 - Trident Blade3D VGA AGP drivers for Win9x/ME, NT4.0, Win2000
 - Audio driver and utility for Win9x/ME, NT and Win2000
 - VIA Service Pack for Win9x/WinNT including Bus Master IDE drivers, AGP VxD and etc.
 - **Optional Value Pack 2001** software group including Norton AntiVirus, AutoSave, ADOBE ActiveShare, Acrobat Reader, Imagemore, X-stop, Appio and Ewalla.

Optional Items

- LTI-2 Panel link adapter for LCD/TV-out
- Front Panel Audio jack (Figure 1-3)
- USB Port Adaptor



Figure 1-1 IDE UDMA-66/100 cable

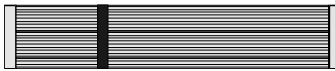

Figure 1-2 Standard Floppy cable



Figure 1-3 Front Panel Audio jack

1-3 Mainboard Layout

CN3,CN4A,CN6
JP1,JP6A

CN2,CN17,CN18

JP5,JP6

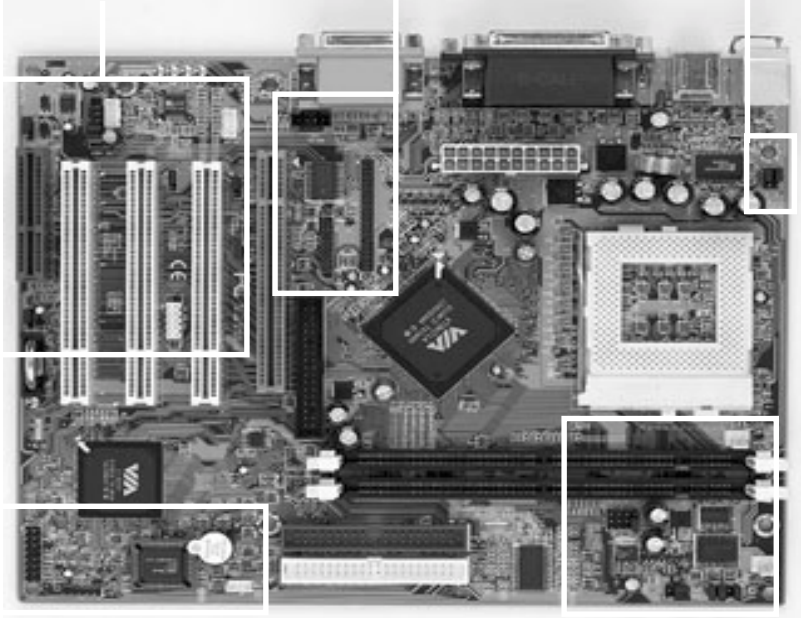

CN1,CN5,IR4

JP2A/JP2B,JP4,
JP20,FAN1,FAN2

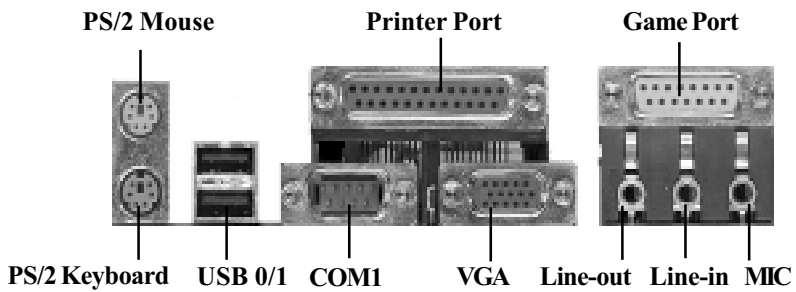

1-4 Connector and Jumper Reference Chart

Jumper & Connector No.	Function	Page
JP1	Clear CMOS Data	13
JP2A/JP2B	External Clock Frequency	8/13
JP4	Frequency Ratio Setting (Optional)	13
JP5	Power On By Keyboard	14
JP6	Power On By USB 0 & 1	14
JP6A	Power On By USB 2 & 3	14
JP20	LCD Type Selector	15
CN1	Over Ride Power Button connector	11
	Power Indicator LED connector	11
	System Reset Switch connector	12
	Speaker connector	12
	Green Switch connector	12
	IDE Activity LED connector	12
CN2	CD-ROM Audio in connector	15
CN3	Auxilliary Audio-in connector	15
CN4A	Front Panel Audio Connector	16
CN5	WOL (Wake-on-LAN) connector	16
USB1/CN6	USB 0/1Ports and USB 2/3 Connector	17
CN17/CN18	Optional TV-Out/DFP Connectors	17
FAN1/FAN2	CPU/System Cooling Fan Connectors	17
IR4	FIR Connector	18
PW1	ATX Power supply connector	10

Chapter 2

Hardware Setup

If your mainboard has already been installed in your computer you may still need to refer to this chapter if you plan to upgrade your system's hardware.

! Be sure to disconnect the power cable from the power source before performing any work on your mainboard, i. e. installing a CPU, memory module, changing a jumper setting, etc. Not doing so may result in electrical shock!

2-1 Introduction to Jumpers

Jumpers are used to select between various operating modes. A jumper consists of a row of gold colored pins that protrude from the surface of the mainboard. It is important not to confuse jumpers with connectors or headers.

! Putting jumper caps on anything that is not a jumper may result in damaging your mainboard. Please refer to Section 1-3, Mainboard Layout, for the location of jumpers on your mainboard.

As indicated in Figure 2-1 below, a cap is used to cover the pins of a jumper, resulting in shorting those pins that it covers. If the cap is removed from the top of the pins, the jumper is left "open." The number 1 shown both in the diagram below and in all multiple pin jumper and header diagrams in this manual indicates the pin designated with the number 1. The numbering of the remaining pins follows in sequence.

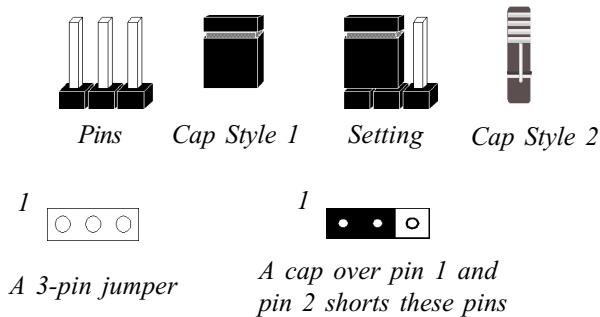

Figure 2-1

2-2 Installing a CPU in a Socket 370

The Intel Socket 370, designed for the Celeron/Coppermine processor, has been incorporated as a standard mainboard specification. To insert your CPU into Socket 370 please do the following:

1. Locate a small dot marked on the top surface of the CPU close to one of its corners. The same corner will also be cut off, leaving a noticeable notch in the CPU's corner. These markings indicate Pin 1 of the CPU.
2. Pull up the lever of Socket 370 so that it is perpendicular with the surface of the mainboard. Gently insert the CPU with Pin 1 at the same corner of Socket 370 that contains the end of the lever. Allow the weight of the CPU to push itself into place. Do not apply extra pressure as doing so may result in damaging your CPU. Snap the lever back into place.



Installing a heat sink with cooling fan is necessary for proper heat dissipation from your CPU. Failing to install these items may result in overheating and possible burn-out of your CPU.

2-3 CPU Jumper Configuration

Frequency Configuration

If you install a CPU on this mainboard, you must set **JP2A/JP2B** for **CPU Bus Frequency**. You can also manually select the Frequency Ratio JP4 (optional) if your CPU is not frequency locked processors. (See Figure 2-3)

* CPU Speed = Frequency ratio x System Frequency

CPU Bus Frequency:

FSB	JP2A	JP2B
Auto	1~2	1~2
66	2~3	2~3
100MHz	Open	2~3
133MHz	-	Open

Figure 2-2

(Optional) Frequency Ratio Configuration:

RATIO	3	3.5	4	4.5	5	5.5	6	6.5	7	7.5	8
1	SHORT	OPEN	SHORT	OPEN	SHORT	OPEN	SHORT	OPEN	SHORT	OPEN	SHORT
2	OPEN	OPEN	SHORT	SHORT	OPEN	OPEN	SHORT	SHORT	OPEN	OPEN	SHORT
3	SHORT	SHORT	OPEN	OPEN	OPEN	OPEN	SHORT	SHORT	SHORT	SHORT	OPEN
4	SHORT	SHORT	SHORT	SHORT	SHORT	SHORT	OPEN	OPEN	OPEN	OPEN	OPEN

Figure 2-3



You do not need to make voltage settings because **SeePU** automatically sets your CPU voltage.

Overclocking

Operating a CPU at a higher frequency than its specification allows is called overclocking. If the CPU frequency is set at a higher frequency than its specification allows, it may or may not run at that frequency, depending on the quality of your CPU and the extent to which the frequency has been overset. The mainboard manufacturer highly discourages overclocking as it may result in data loss, CPU burn-out, system failure, etc.

Many processors are frequency locked processors and are not able to perform overclocking. Regardless of whether the processor is a frequency locked, overclocking may cause some processors to hang when turning on the system. When the processor hangs, the screen remains blank and the system does not boot. To solve this problem, do the following.

- 1. Turn off the computer and then press the Home key on your keyboard*
- 2. Turn on your computer, wait for five seconds and then release the Home key. (Pressing the Home key allows the computer to boot at a low system speed.)*
- 3. Enter BIOS and reconfigure your CPU parameters.*

2-4 Connector and Jumper Settings

Connectors are used to link the system board with other parts of the system, including the power supply, the keyboard, and the various controllers on the front panel of the system case.



The power supply connector is the last connection to be made while installing a mainboard. Before connecting the power supply, please make sure it is not connected to the power source.

ATX Power Supply Connector (PW1)

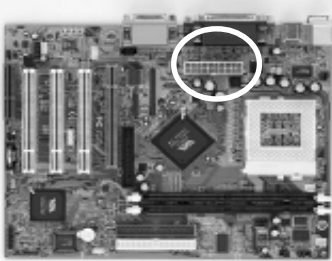

The power cord leading from the system's power supply to the external power source must be the very last part connected when assembling a system.

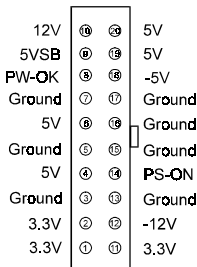

The ATX power supply provides a single 20-pin connector interface which incorporates standard +/-5V, +/-12V, optional 3.3V and Soft-power signals. The Soft-power signal, a 5V trickle supply is continuously supplied when AC power is available. When the system is in the Soft-Off mode, this trickle supply maintains the system in its minimum power state.

Software Power-Off Control

This mainboard can be powered down using the Windows 95 Software Power-Off function. To power down your computer, click the START button on the Windows 95 task bar. Select "Shut Down The Computer" and the system turns off. The message "It is now safe to turn off your computer" will not be shown when using this function.

Power-On By Modem

While in Soft-off state, if an external modem ring-up signal occurs, the system wakes up and can be remotely accessed. You may enable this function in BIOS's Power Management Setup menu. (See section 3-5)

Front Panel Connector Set (CN1) A through F

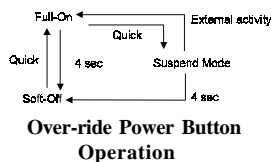
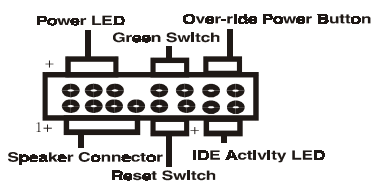
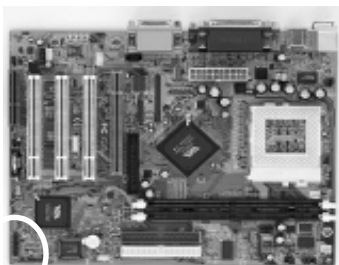

A. Over-ride Power Button Connector

The power button on the ATX chassis can be used as a normal power switch as well as a device to activate Advanced Power Management Suspend mode. This mode is used for saving electricity when the computer is not in use for long periods of time. The Soft-OFF by PWR-BTTN function in BIOS's Power Management Setup menu must be set to "Delay 4 Sec." to activate this function. (See section 3-5)

When the Soft-OFF by PWR-BTTN function is enabled, pushing the power button rapidly will switch the system to Suspend mode. Any occurrence of external activities such as pressing a key on the keyboard or moving the mouse will bring the system back to Full-On. Pushing the button while in Full-On mode for more than 4 seconds will switch the system completely off. See Over-ride Power Button Operation diagram.

B. Power Indicator LED Connector

The power indicator LED shows the system's power status. It is important to pay attention to the correct cables and pin orientation (i.e., not to reverse the order of these two connectors.)

Pin	Definition
1	+5V DC
2	Not Connected
3	Ground

Blinking LED in Suspend Mode

While in Suspend mode, the LED light on the front panel of your computer will flash. Suspend mode is entered by pressing the Override Power Button, pushing the Green button on your ATX case, or enabling the Power Management and Suspend Mode options in BIOS's Power Management menu. (See section 3-5)

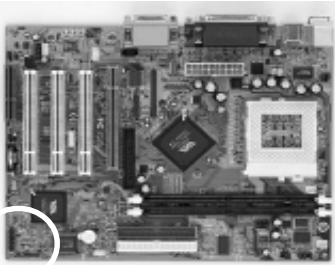

C. Green Switch Connector

Some ATX cases provide a Green switch which is used to put the system in Suspend mode. In Suspend mode, the power supply to the system is reduced to a trickle, the CPU clock is stopped, and the CPU core is in its minimum power state. The system is woken up whenever the keyboard or mouse is touched. The system resumes in different ways as defined by Power Management Setup screen in BIOS.

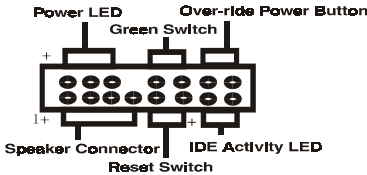

D. System Reset Switch Connector

This connector should be connected to the reset switch on the front panel of the system case. The reset switch allows you to restart the system without turning the power off.

Pin	Definition
1	System Reset
2	GROUND

E. Speaker Connector

Pin	Definition
1	+5V DC
2	No Connection
3	No Connection
4	Speaker Signal

F. IDE Activity LED Connector

The IDE activity LED lights up whenever the system reads/writes to the IDE devices.

Poly-fuse Over Current Protection

The poly-fuse protects the system from dangerous voltages the system might be exposed to via the keyboard or USB connectors. In case of such exposure, the poly-fuse will immediately be disconnected from the circuit, just like a normal fuse. After being disconnected for a certain period of time, the poly-fuse will return to its normal state, after which the keyboard or USB can function properly again. Unlike conventional fuses, the poly-fuse does not have to be replaced, relieving the user wasted time and inconvenience.

Clear CMOS Data (JP1)

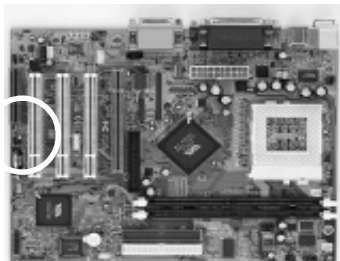

Normal (default)



Clear CMOS data

To clear the contents of the CMOS, please follow the steps below.

1. Disconnect the system power supply from the power source.
2. Set the jumper cap at location 2~3 for 5 seconds, then set it back to the default position.
3. Connect the system's power and then start the system.
4. Enter BIOS's CMOS Setup Utility and choose Load Setup Defaults. Type Y and press enter.
5. Set the system configuration in the Standard CMOS Setup menu.

External Clock Frequency (JP2A/JP2B)

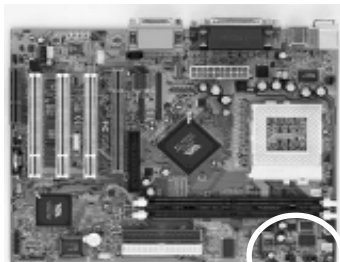

This jumper allows the system bus frequency to be determined either by CPU or the user. If set both JP2A/JP2B pins to 1-2, the CPU determines the system bus frequency speed. Set both JP2A/JP2B pins to 2-3 for 66MHz FSB, set only JP2B pins to 2-3 for 100MHz FSB and leave both JP2A/JP2B pins open for 133MHz FSB.

FSB	JP2A	JP2B
Auto	1-2	1-2
66	2-3	2-3
100MHz	Open	2-3
133MHz	-	Open

Optional Frequency Ratio Setting (JP4)

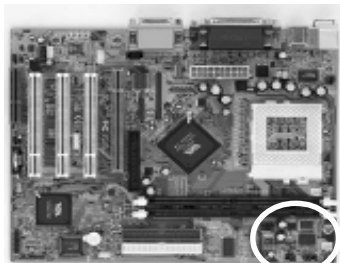

This feature allows you to set a CPU at a higher frequency clock ratio than it's specification allows. it may or may not run at that ratio, depending on the quality of your CPU and the extent to which the ratio has been overset.

RATIO	3	3.5	4	4.5	5	5.5	6	6.5	7	7.5	8
1	SHORT	OPEN	SHORT	OPEN	SHORT	OPEN	SHORT	OPEN	SHORT	OPEN	SHORT
2	OPEN	OPEN	SHORT	SHORT	OPEN	OPEN	SHORT	SHORT	OPEN	OPEN	SHORT
3	SHORT	SHORT	OPEN	OPEN	OPEN	OPEN	SHORT	SHORT	SHORT	SHORT	OPEN
4	SHORT	SHORT	SHORT	SHORT	SHORT	SHORT	OPEN	OPEN	OPEN	OPEN	OPEN



This option will not work with frequency lock CPU.

Power On By Keyboard (JP5)

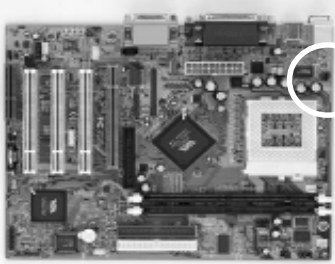

1 Disable(default) 1 Enable

This board is able to be turned on by the PS/2 keyboard (hot key). To use this function, select a hot key of your choice at the PS2KB Wakeup option under Wake Up Events in the BIOS's Power On Management screen. You must also set this jumper's cap to pins 2-3 to use this function.

Power On By USB 0 &1 (JP6)

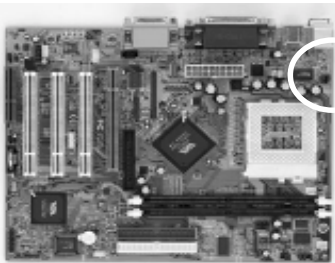

1 Disable(default) 1 Enable

This board is able to be turned on by a USB keyboard hot key or a USB mouse click. To use this function, select a hot key of your choice at the USB Resume From S3/S4/S5 option under Wake Up Events in the BIOS's Power On Management screen. You must also set this jumper's cap to pins 2-3 to use this function.

Power On By USB 2 & 3 (JP6A)

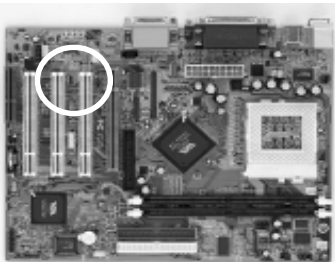

1 Disable (default) 1 Enable

This board is able to be turned on by a USB keyboard hot key or a USB mouse click. To use this function, select a hot key of your choice at the USB Resume From S3/S4/S5 option under Wake Up Events in the BIOS's Power On Management screen. You must also set this jumper's cap to pins 2-3 to use this function.

LCD Type Selector (JP20)

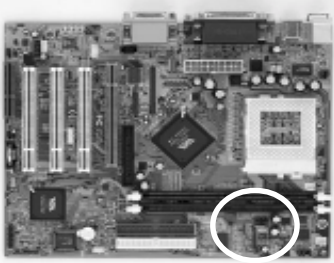

This feature allows you to turn On/Off the LCD function and also let you select the LCD type and resolution setting. See the table below for your LCD type and resolution setting.

LCD On/Off MODE	A
LCD OFF	2-3
LCD ON	1-2

LCD TYPE	LCD Resolution	D	C	B
TFT	1024x768x18-bit	2-3	2-3	2-3
TFT	1280x1024x18-bit	2-3	2-3	1-2
TFT	800x600x18-bit	2-3	1-2	2-3
TFT	1024x600x18-bit	2-3	1-2	1-2
DSTN	1024x768x16-bit	1-2	2-3	2-3
DSTN	1024x600x24-bit	1-2	2-3	1-2
DSTN	800x600x16-bit	1-2	1-2	2-3
DSTN	1024x768x24-bit	1-2	1-2	1-2

CD-ROM Audio-in (CN2)

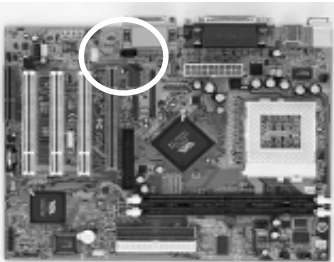

Use the audio cable enclosed with your CD-ROM disk drive to connect the CD-ROM to your mainboard. This will enable your CD-ROM's audio function.

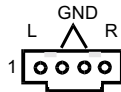

Auxiliary Audio-in (CN3)

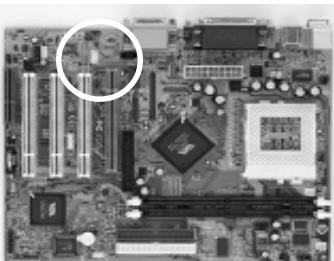

This connector is for use with a secondary CD-ROM, DVD-ROM or CDR/CDRW disk drive.

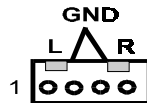

Front Panel Audio Connector (CN4A)

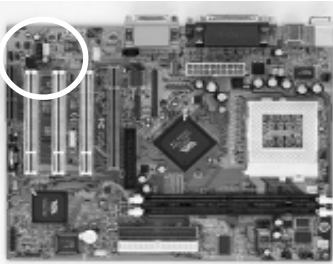

This connector give you the option to choose between standard audio jack(rear panel) or use a an optional front panel audio jack cable ext. to be plug into a special custom designed system case.

To use the standard audio jack short jumper caps to pin1-2 and pin 3-4 (Default). To use the front panel audio jack cable ext., simply removed both jumper caps and plug into the audio jack cable.

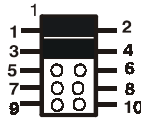

Standard Rear Panel

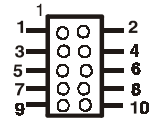

Front Panel

WOL (Wake-on-LAN) Connector (CN5)

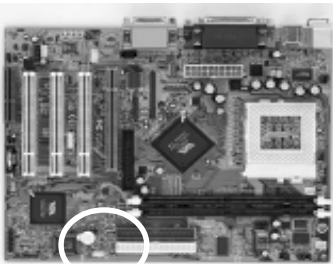

Enable the Wake Up On LAN selection in BIOS's Power Management Menu to use this function. The capability to remotely manage PCs on a network is a significant factor in reducing administrative and ownership costs. Magic Packet technology is designed to give WOL (Wake-on-LAN) capability to the LAN controller. When a PC capable of receiving wake up command goes to sleep, the Magic Packet mode in the LAN controller is enabled. When the LAN controller receives a Magic Packet frame, the LAN controller will wake up the PC. This header is used to connect an add-in NIC (Network Interface Card) which gives WOL capability to the mainboard.

To support this function, a switching power supply with a minimum of 750mA 5VSB standby signal is required.

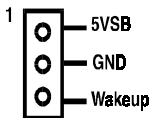

USB 0/1Ports and USB 2/3 Connector (USB1/CN6)

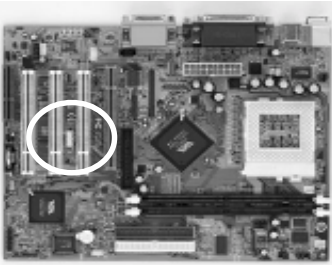

If you want to use a USB keyboard, you must enable the USB keyboard support function in BIOS's Integrated Peripherals menu (See Section 3-4).

This board contains a USB Host controller and includes a root hub with two USB ports (meets USB Rev 1.0 spec.) and a connector for optional USB Adaptor (USB2/3). Four USB peripherals or hub devices are able to be connected.

Optional TV-Out/DFP Connectors (CN17/CN18)

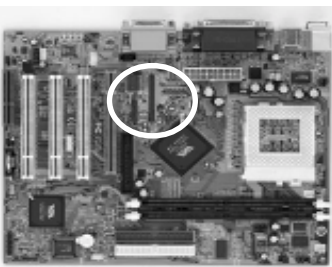

The connectors are to be connected to an optional TV-Out/DFP adaptor card.

CPU/System Cooling Fan Connectors (FAN1/FAN2)

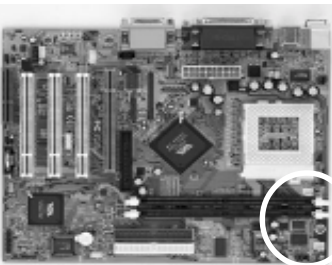

These added connectors allow the fan to draw their power from the mainboard instead of the disk drive connector.

The board's management extension hardware is able to detect the CPU and system fan speed in rpm (revolutions per minute). These connectors supports 3-pin cooling fans with minimum of 3500 RPM. The wiring and plug may vary depending on the manufacturer. On standard fans, the red is positive (+12V), the black is ground, and the yellow wire is the rotation signal.

FIR Connector (IR4)

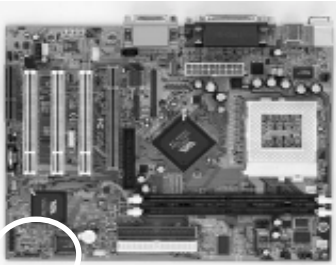

If you enable the UART Mode in BIOS's Integrated Peripherals menu the UART port will support FIR functions. (See section 3-4)

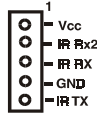

Audio Mono-in/out Connector (CN4)

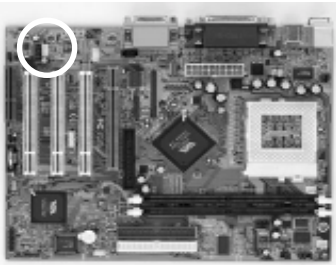

This connector is used for Add on Card e.g. modem with Mono In/Out connector

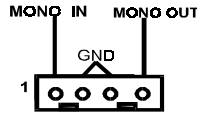

2-5 Main Memory Configuration

The DRAM memory system consists two banks and the memory size ranges from 32~512MBytes. If you only use one bank it does not matter which one you use and if you use two or more banks, it does not matter which bank you install first.

DIMM1	Bank0
DIMM2	Bank1

DRAM Specifications

FSB	SDRAM Type	SDRAM Type	Max Memory
66	FSB+33	10ns or faster	1GB
100	FSB	10ns or faster	
	FSB+33	7.5ns or faster	
133	FSB-33	10ns or faster	
	FSB	7.5ns or faster	

DIMM type: 3.3V, 64/72-bit Synchronous DRAM
 Module size: Single/double-sided 32/64/128/256/512MBytes
 DRAM speed: 7.5/10ns for Synchronous DRAM
 Parity: Either parity or non-parity



This mainboard supports 3.3v, unbuffered, 4-clock, SDRAM DIMM only. Buffered, 5V, or 2-clock SDRAM DIMMs should not be used.



Due to loading anomalies, using DIMM with an 'n x 4' DRAM base on this mainboard is not recommended. For example, a DIMM that uses sixteen 16Mb x 4 devices should not be used.



Memo

Chapter 3

Award BIOS Setup Program

Award's BIOS ROM has a built-in setup program that allows users to modify the basic system configuration. This information is stored in CMOS RAM so that it can retain the setup information, even when the power is turned off.

When you turn on or restart the system, press the Delete key to enter the Award BIOS setup program. The primary screen as shown in Figure 3-1 is a list of the menus and functions available in the setup program. Select the desired item and press enter to make changes. Operating commands are located at the bottom of this and all other BIOS screens. When a field is highlighted, on-line help information is displayed on the right side of the screen.

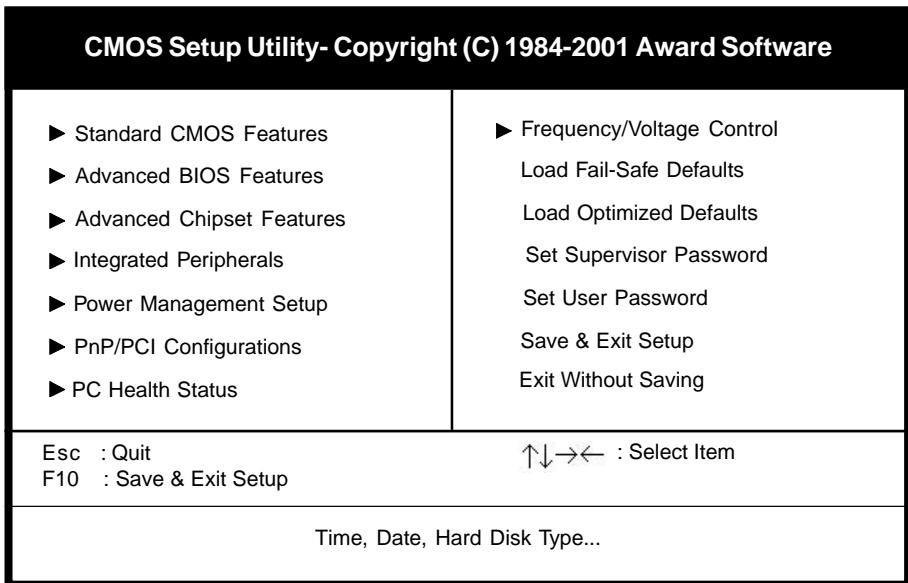

Figure 3-1 Setup Program Initial Screen

3-1 Standard CMOS Features

The Standard CMOS Features allows users to configure system components such as hard disk drive, floppy disk drive and video display as well as date, time and boot up error signaling. This configuration menu should be changed when installing a mainboard for the first time, changing hardware in your system such as the HDD, FDD, video display, or when the CMOS data has been lost or contaminated. Choose the Standard CMOS Setup option from the CMOS Setup Utility menu (Figure 3-1) to display the following screen. When a field is highlighted, on-line help information is displayed on the left bottom edge of the screen.

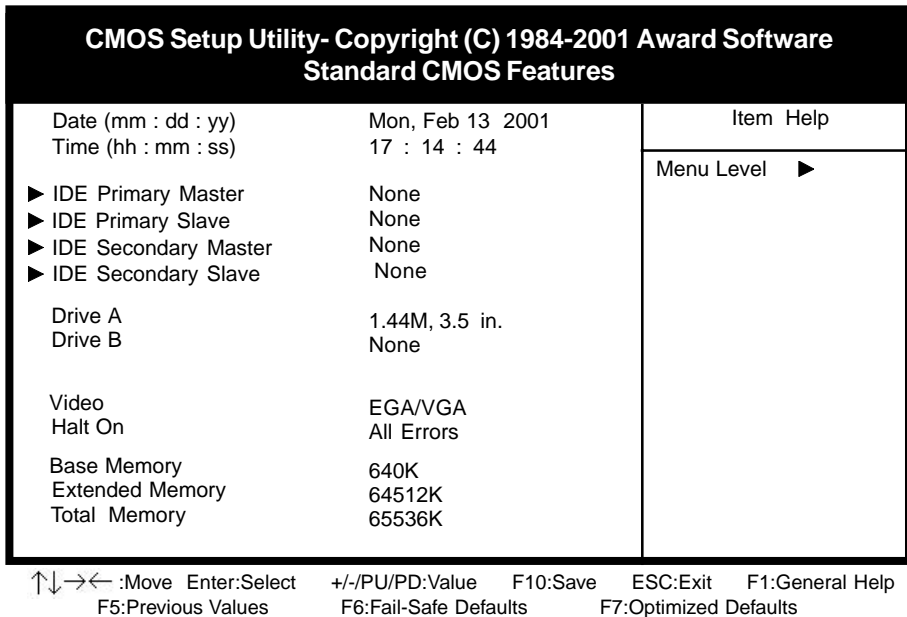

Figure 3-2 Standard CMOS Features Screen

Date/Time

Set the date and time. Do not skip this function as all of your timed events such as power management, saving files, etc. are based on this timer.

Hard Disk Setup (Primary/Secondary; Master/Slave)

This category identifies up to four IDE hard disk drives that have been installed in the computer. This section does not show information on other IDE devices such as CD-ROM drives or other hard drive types such as SCSI drives.

Type (Auto/User/None): Use the fields under the Type column to determine the method you will use to configure the IDE devices. If you choose Auto, BIOS will automatically detect and make optimal settings for most IDE hard drives.



The mainboard manufacturer recommends that you choose Auto for all drives.

Choose User to define your own drive type manually. You must enter values indicated in the table below into each drive parameter field. This information should be included in the documentation from your hard disk vendor or system manufacturer:

TYPE	Setting method
CYLS	Number of cylinders
HEAD	Number of heads
PRECOMP	Write precompensation cylinder
LANDZ	Landing zone
SECTOR	Number of sectors
MODE	Mode type

Table 3-1 Hard Disk Drive Parameters

Cyls/Head/Sector: The number of Cylinders, Heads, and Sectors can usually be found written on the top of the hard disk. If you have a relatively new hard drive, entering this information alone is usually sufficient for normal hard disk operation. The hard disk will not work properly if you enter improper information for these categories.

Precomp: Older hard drives (i.e., MFM or RLL drives) have the same number of sectors per track at the innermost tracks as at the outermost tracks. Thus, the data density at the innermost tracks is higher and the bits are lying closer together. Even though the physical size of a sector gets progressively smaller as the track diameter diminishes, each sector must still hold 512 bytes. Write precompensation circuitry compensates for the difference in sector size by boosting the write current for inner track sectors.

Landz: This defines the address of the landing zone and is only used for older hard drives which do not have an auto-parking feature.

Mode: If the Type value is not None for any device, you must set the Mode value for that device. There are four different Mode values: Auto, Normal, Large, and LBA.

* **Auto** - BIOS detects and enters the IDE drive type during boot up.

* **Normal** - for IDE drives that meet the old IDE specification which support a maximum capacity of 528MB (1024 cylinders, 16 heads, and 63 sectors).

* **Large** - for IDE drives that do not support LBA and have more than 1024 cylinders. Try this setting if your hard disk does not operate properly with the LBA setting. Large mode is not supported by all operating systems, i.e., only certain versions of DOS support large mode.

* **LBA** - (Large/Logical Block Addressing) With LBA, the IDE controller transforms the data address described by sector, head, and cylinder number into a physical block address, significantly improving data transfer rates. This mode is for drives with greater than 1024 cylinders and between 528MB and 8.4GB in size. This protocol is the current common standard.

Choose None for Type if there are no IDE HDD devices in your system.

- ☞ You can use the IDE HDD Auto Detection function to auto detect your hard drive parameters. Using this function will automatically insert the parameters discussed under Hard Disk Setup and will indicate User for the Field value. Please see Section 3-9 for more information.

Floppy Disk Drives

Choose the memory capacity and disk size that corresponds with that of your floppy disk drive(s).

Video

Select the type of video adapter present in your system. You can ignore this setting if you are using a VGA monitor since VGA BIOS automatically configures this setting.

Halt

When the system is powered on, BIOS performs a series of diagnosis tests called POST (Power On Self Test). This function stops the computer if BIOS detects a hardware error. You can tell BIOS to halt on all errors, no errors, or not to halt on specific errors.

3-2 Advanced BIOS Features

By choosing the Advanced BIOS Features option from the CMOS Setup Utility menu (Figure 3-1), the screen below is displayed. This sample screen contains the manufacturer's default values for the mainboard.

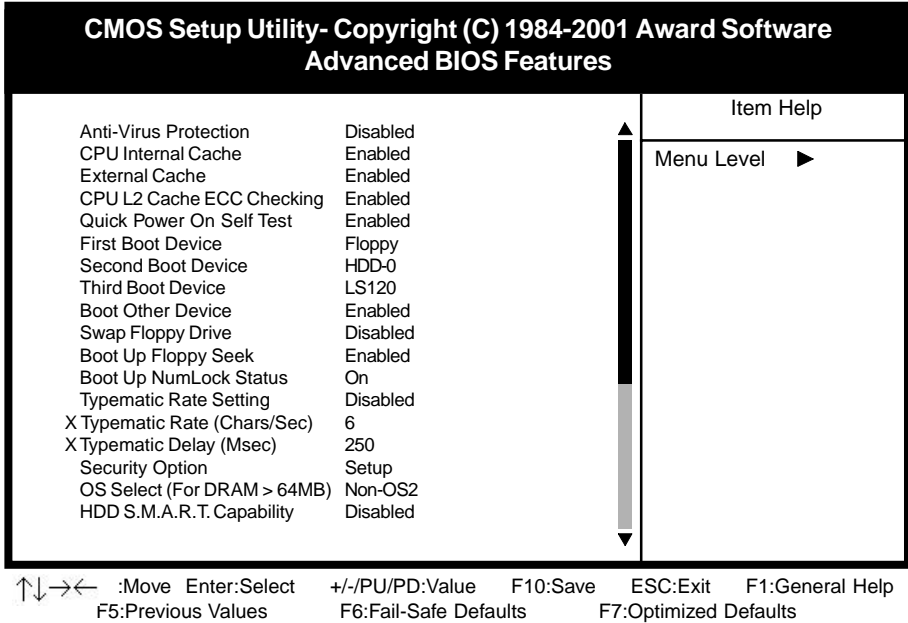

Figure 3-3 Advanced BIOS Features Screen

A. Anti-Virus Protection

Trend ChipAway Virus

Trend ChipAway Virus is a code incorporated in the mainboard's BIOS firmware. During the boot-up sequence, BIOS loads before loading of the partition table or boot sector. ChipAway Virus loads with BIOS and is able to detect boot-up viruses before they have a chance to infect the hard drive. ChipAway Virus employs rule-based logic that doesn't look for specific viruses but rather detects patterns found in every virus, eliminating the need to perform periodical version updates after new viruses have been found.

B. Cache Control

CPU Internal Cache/External Cache

Cache memory is much faster than conventional DRAM system memory. These fields allow you to enable or disable the CPUs Level 1 built-in cache and Level 2 external cache. Both settings are left enabled to significantly increase the performance of your computer.

C. Boot Up Features

After turning on the system, BIOS will perform a series of device initialization and diagnostic tests discussed below.

Quick Power On Self Test (POST)

Enable this function to reduce the amount of time required to run the POST (Power On Self Test). BIOS saves time by skipping some items during POST. It is recommended that you disable this setting. Discovering a problem during boot up is better than losing data during your work.

First/Second/Third/Boot Other Device

This option sets the sequence of drives BIOS attempts to boot from after POST completes. BIOS will search these drives for an operating system.

Swap Floppy Drive

Enabling this function will swap the floppy drive assignment so that drive A will function as drive B, and drive B will function as drive A. Note that the boot sequence assignment mentioned directly above does not include booting from floppy drive B. This function is useful if floppy drives B and A are of a different format and you want to boot from floppy drive B.

Boot up Floppy Seek

During POST, BIOS will determine if the installed floppy disk drive has 40 or 80 tracks. A 360K drive has 40 tracks and 720K, 1.2M and 1.44M drives have 80 tracks. All modern floppy disk drives have 80 tracks.

Boot Up NumLock Status

This function defines the keyboard's number pad as number keys or arrow keys.

D. Keyboard Interface

Typematic Rate Setting

When enabled, you can set the following two typematic control items. When disabled, keystrokes are determined arbitrarily by the keyboard controller in your system.

Typematic Rate (Chars/Sec)

The typematic rate sets the rate at which characters on the screen repeat when a key is pressed and held down.

Typematic Delay (Msec)

The typematic delay sets how long after you press a key that a character begins repeating.

E. Security Option

The Supervisor and/or User Password functions shown in Figure 3-1 must be set to take advantage of this function. See Section 3-11 for password setting information. When the Security Option is set to System, a password must be entered to boot the system or enter the BIOS setup program. When the Security Option is set to Setup, a password is required to enter the BIOS setup program.

F. OS Select (For DRAM >64MB)

If your system's DRAM is larger than 64MB and you are running OS/2, select OS/2 as the item value. Otherwise, set the item value to Non-OS/2 for all other operating systems.

G. HDD S.M.A.R.T. Capability

S.M.A.R.T. or Self-Monitoring, Analysis, and Reporting Technology enables a drive's internal status to be monitored through diagnostic commands. Both your hard drive must support this capability and this function must be enabled in order to take advantage of this function. See your hard drive literature for more information.

H. Shadow Memory

Software such as system BIOS, video BIOS, SCSI BIOS, etc that resides in ROM (Read Only Memory) chips is called firmware. Shadowing of firmware occurs when BIOS is copied to RAM address C0000h through DFFFFh. Video BIOS loads into the C0000-C7FFF memory area when video shadowing is enabled. If an expansion peripheral in your system contains ROM-based firmware, you need to know the address range the ROM occupies to shadow it into the correct area of RAM.

Shadowing improves the firmware's performance because the firmware can be read by the CPU through the 16- or 32-bit DRAM bus as opposed to the 8-bit XT bus. However, shadowing also results in reducing the amount of high memory (640 KB to 1 MB) for loading device drivers. Shadowing is used mostly for ROM chips on ISA cards and not for PCI cards. Shadowing and playing games at the same time may result in system instability as some games access the RAM memory area being shadowed.

I. HDD Instant Recovery

*This board supports HDD Instant Recovery, select enabled to use this function. Upon system boot up, the HDD Instant Recovery Utility will be shown on the screen. Selet **Install** or **Do Not Install** to continue booting. (See Appendix III)*

3-3 Advanced Chipset Features

By choosing the Advanced Chipset Features option from the CMOS Setup Utility menu (Figure 3-1), the screen below is displayed. This sample screen contains the manufacturer's default values for the mainboard.

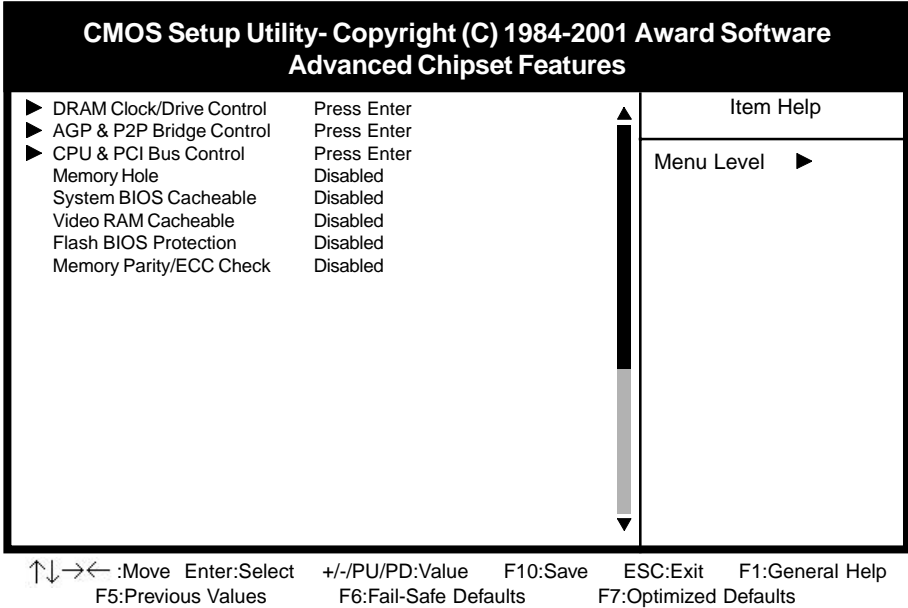

Figure 3-4 Chipset Features Setup Screen



All of the above settings have been determined by the mainboard manufacturer and should not be changed unless you are absolutely sure of what you are doing. Explanation of the DRAM timing and chipset features setup is lengthy, highly technical and beyond the scope of this manual. Below are abbreviated descriptions of the functions in this setup menu. You can look on the world wide web for helpful chipset and RAM configuration information including AWARD's web site at <http://www.award.com>.

A. DRAM Clock/Drive Control

DRAM Timing By SPD

The function allows you to enable or disable the DRAM timing by SPD. When Disabled, you can select the DRAM Clock, SDRAM Cycle Length and Bank Interleave configuration.

SDRAM Cycle Length

When synchronous DRAM is installed, the number of the clock cycles of CAS latency depends on the DRAM timing. Do not reset this setting from the default value specified by the system designer.

B. AGP & P2P Bridge Control

AGP Aperture Size

This function determines the amount of system memory that is given to the AGP card. Options range from 4MB to 128MB. This is a dynamic memory allotment in that the AGP card will only use the amount of memory that it needs. The remaining memory not in use will be available for the system to use. For example, if 16MB is allotted to the AGP card and the card only needs 8MB, the remaining 8MB will be available for system use.

C. CPU & PCI Bus Control

PCI Master 0 WS Write

When Enabled, writes to the PCI bus are executed with zero wait states.

PCI Delay Transaction

The chipset has an embedded 32-bit posted write buffer to support delay transactions cycles. Select Enabled to support compliance with PCI specification version 2.1.

D. Memory Hole at 15M-16M

Enabling this function will reserve the memory address space between 15MB and 16MB for ISA expansion cards. However, enabling this function will result in not allowing the system to have access to memory above 16MB. Please note that some expansion cards require this setting to be enabled. The default setting is Disabled. If Auto Configuration is enabled, you must set the DRAM timing function to 60ns or 70ns, depending on the type of DRAM you install.

E. System BIOS Cacheable

Enabling this function allows caching of the system BIOS ROM at F0000h-FFFFFh, resulting in better system performance. However, if any program writes to this memory area, a system error may result. Caching the system BIOS results in better performance than shadowing the system BIOS as discussed in Section 3-2.

F. Video RAM Cacheable

Enabling this function will allow caching of the video RAM, resulting in better system performance. However, if any programs write to this memory area, a system error may occur.

G. Flash BIOS Protection

The mainboard manufacturer developed BIOS protection technology that protects the System BIOS from accidental corruption by unauthorized users or computer viruses. When enabled, the BIOS data cannot be changed when attempting to update BIOS with the FLASH utility. When disabled, the BIOS data can be updated by using the FLASH utility.

H. Memory Parity/ ECC Check

This mainboard support the Parity / ECC checking function. If you select "Enabled" in this field, it will detect the memory parity and Error Checking & Correcting.

3-4 Integrated Peripherals

This section provides information on setting peripheral devices. By choosing the Integrated Peripherals option from the CMOS Setup Utility menu (Figure 3-1), the screen below is displayed. This sample screen contains the manufacturer's default values for the mainboard.

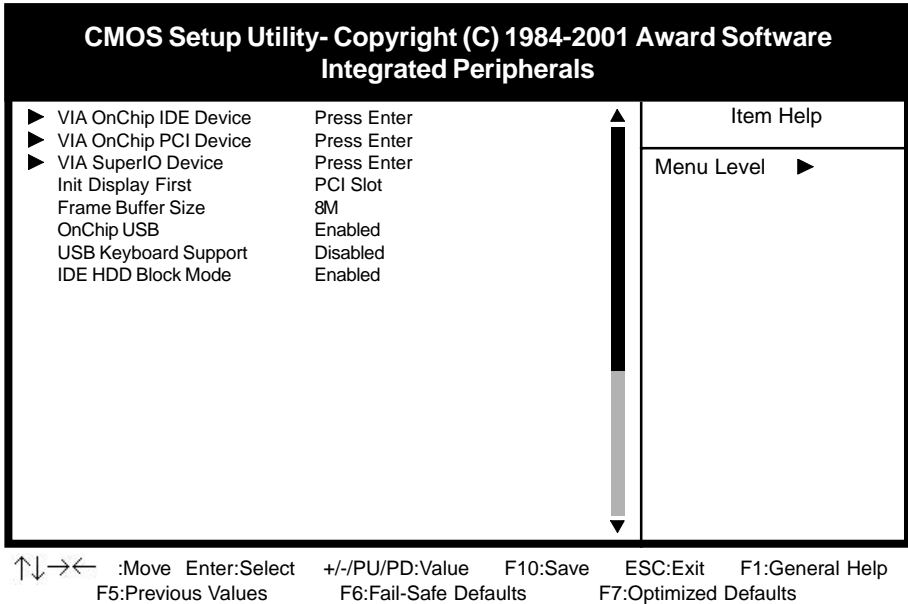

Figure 3-5 Integrated Peripherals Screen

A. VIA OnChip IDE Device

OnChip IDE channel 0/1

You can set this to disable the OnChip IDE controller if you are going to add a higher performance IDE board.

IDE Primary/Secondary Master/Slave PIO

The four IDE PIO (programmed Input/Output) fields let you set a PIO mode (0-4) for each IDE device that the internal PCI IDE interface supports. Modes 0 through 4 provide successively increased performance. In Auto mode, the system automatically determines the best mode for each device.

B. VIA OnChip PCI Device

VIA MC97 Modem

This feature allows you to enable the on-board modem function.

VIA AC97 Audio

This feature allows you to enable the on-board audio function.

VIA OnChip LAN

This feature allows you to enable the on-board LAN function

C. VIA Super IO Device

Onboard FDC Controller

Select Enabled if your system has a floppy disk controller (FDC) installed on the system board and you wish to use it. If you install an add-in FDC or the system has no floppy drive, select Disabled in this field.

Onboard Serial Port

This function allows you to select a logical serial port address and corresponding interrupt for the physical serial port.

Onboard Parallel Port

Select a logical LPT port address and corresponding interrupt for the physical parallel port.

Parallel Port Mode

Select an operating mode for the onboard parallel (printer) port. Select SPP unless you are certain your hardware and software support one of the other available modes.

On Board FIR Select

This function allows you to select an IRQ for the FIR(Fast Infrared) port.

D. Init Display First

This function allows user to choose between Onboard(AGP) or PCI slot to initialize Display first .

E. OnChip USB

Enable the on-board Universal Serial Bus (USB) controller if you want to connect a USB keyboard to your system. Note that if this setting is disabled, you can still temporarily use a USB keyboard during bootup so that you can enter BIOS and enable this setting. If you pass the bootup stage without enabling this function, your PS/2 keyboard will no longer work.

F. USB Keyboard Support

Select Enabled if your system has a USB keyboard installed on the system board. If your system has no USB keyboard, select Disabled in this field.

G. IDE HDD Block Mode

Block mode is also called block transfer, multiple commands, or multiple sector read/write. If your IDE hard drive supports block mode, select Enabled to auto-detect the optimal number of block read/writes per sector the drive can support.

3-5 Power Management Setup

This section provides information on the Green PC power management functions. By choosing the Power Management Setup option from the CMOS Setup Utility menu (Figure 3-1), the screen below is displayed. This sample screen contains the manufacturer's default values for the mainboard

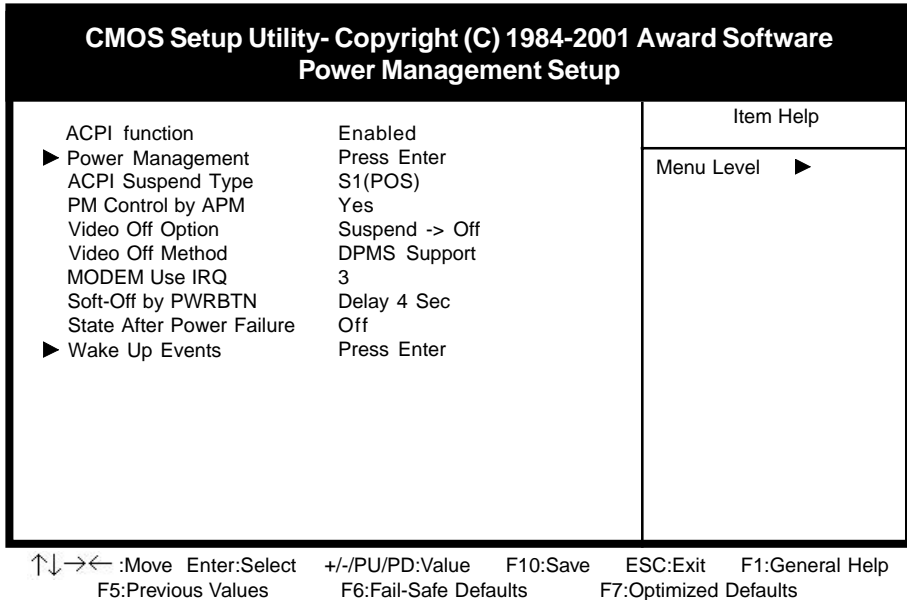

Figure 3-6 Power Management Setup Screen

A. Advanced Configuration Power Interface (ACPI)

ACPI management enables the operating system to control the amount of power given to each device attached to the computer. With ACPI, the operating system can turn off peripherals devices, such as CD-ROM players, when they are not in use.

B. Power Management

Power management allows the computer to save electricity when it is not in use by entering increasingly deep power saving modes as shown by the diagram below.

C. Video Off Option

This setting allow you to selects the power-saving modes during which the monitor goes blank.

D. Video Off Method

This function serves as both a screen saver and power saver for monitors. See the next function, Video Off After, for setting the video timer.

Blank - BIOS will only blank the monitor's screen. The electricity saved in this mode is negligible and this function is only used as a screen saver to prevent screen damage while the screen is on but not in use.

V/H SYNC+Blank - The system turns off the vertical and horizontal synchronization ports, writes blanks to the VGA buffer and the monitor's electron gun turns off. This function requires a monitor with Green features in order to take advantage of the power saving function. If you enable this function and

do not have a Green monitor, the result will be the same as if you had selected Blank. This function serves as both a screen saver and an electricity saver.

DPMS Supported - Select this option if your video card supports the Display Power Management Signaling (DPMS) standard (i.e., you have a monitor that supports Green features). Use software supplied by your video subsystem to set video power management options.

E. Modem Use IRQ

If your computer has an modem, use this function to tell BIOS which IRQ is being occupied by the modem card. When the system is in Green mode, the modem requires an IRQ assignment to wake up the system and perform tasks. This assignment is compliant with the APM 1.2 specification and is to be used in coordination with APM 1.2 compliant operating systems.

F. Soft-Off by PWR-BTTN

When set to Delay 4 Sec., this function allows the power button to put the system in Suspend, a power saving mode. See Section 2-4 for operation instructions of the override power button operation which puts the system in Suspend mode. When set to Instant-Off the Soft-Off by PWR-BTTN function is disabled and the computer turns completely off when the power button is pressed.

G. Power On By PCI Card

When enabled, a PCI card that receives a signal will wake up the system from soft off and green mode.

H. Power On By Modem

When enabled, a modem that receives a signal will wake up the system from soft off and green mode. You should connect the modem to the COM port and turn on the resume event in green mode.

I. Power On By Alarm

When enabled, this setting allows the system to turn back on at a designated time of the month. User must designate date of month and time of day. This function is only available when using an ATX power supply and the Software Power-Off function to turn off the computer. See the Software Power-Off feature in Section 2-4 of this manual for instructions.

3-6 PNP/PCI Configuration

This section provides IRQ and DMA setting information. By choosing the PNP/PCI Configuration option from the CMOS Setup Utility menu (Figure 3-1), the screen below is displayed. This sample screen contains the manufacturer's default values for the mainboard.

CMOS Setup Utility- Copyright (C) 1984-2001 Award Software		Item Help
PnP/PCI Configurations		Menu Level ▶
PNP OS Installed	No	
Reset Configuration Data	Disabled	
Resources Controlled By	Auto(ESCD)	
X IRQ Resources	Press Enter	
X DMA- Resources	Press Enter	
PCI/VGA Palette Snoop	Disabled	
Assign IRQ For VGA	Enabled	
Assign IRQ For USB	Enabled	
Slot 1 Use IRQ No.	Auto	
Slot 2 Use IRQ No.	Auto	
Slot 3 Use IRQ No.	Auto	
FDD IRQ Can Be Free	Yes	

↑↓→← :Move Enter:Select +/-/PU/PD:Value F10:Save ESC:Exit F1:General Help
 F5:Previous Values F6:Fail-Safe Defaults F7:Optimized Defaults

Figure 3-7 PnP/PCI Configurations Screen

A. PNP OS Installed

If you want to install a PNP compatible OS(such as Windows 95) set to Yes.

B. Resources Controlled By

When set to Manual the system BIOS will not refer to the ESCD for IRQ & DMA information. Instead, it will refer to the items in the setup menu for assigning IRQ & DMA. When set to Auto the system BIOS will refer to the ESCD for all legacy information.



ESCD (Extended System Configuration Data) provides a detailed format of the configuration data structures stored in flash memory. Each data structure defines the resources used by a device or a card in the system. This includes legacy and PCI/ISA PnP devices.

C. FDD IRQ Can Be Free

This function allows user to choose if the FDD IRQ is able to be freed up. The default setting is Yes and this does not allow the IRQ to be free.

3-7 PC Health Status

By choosing the PC Health Status option from the CMOS Setup Utility menu (Figure 3-1), the screen below is displayed. This sample screen contains the manufacturer's default values for the mainboard.

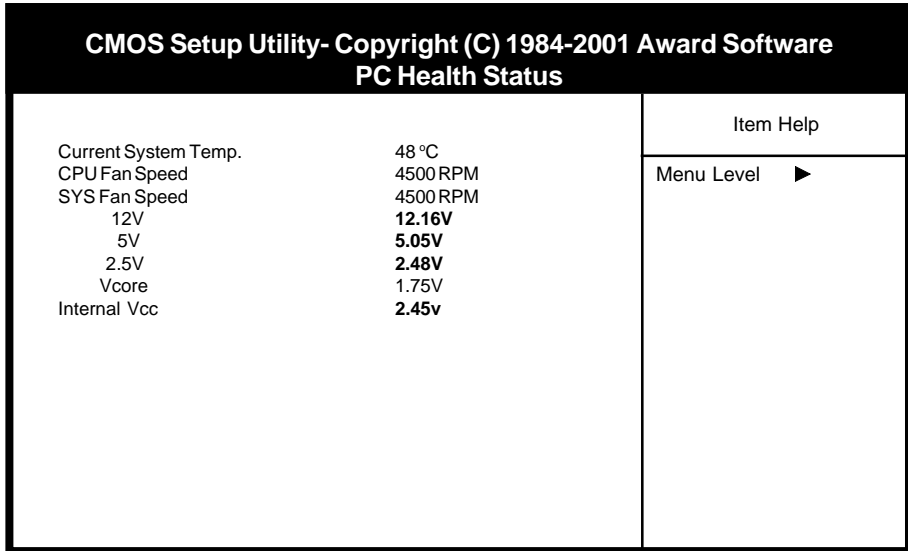

↑↓→← :Move Enter:Select +/-/PU/PD:Value F10:Save ESC:Exit F1:General Help
F5:Previous Values F6:Fail-Safe Defaults F7:Optimized Defaults

Figure 3-8 PC Health Status Screen

This field shows you the current system temperature/external voltages input and the current CPU FAN and System FAN operating speed.

3-8 Frequency/Voltage Control

By choosing the **Frequency/Voltage Control** Setup option from the CMOS Setup Utility menu (Figure 3-1), the screen below is displayed. This sample screen contains the manufacturer's default values for the mainboard.

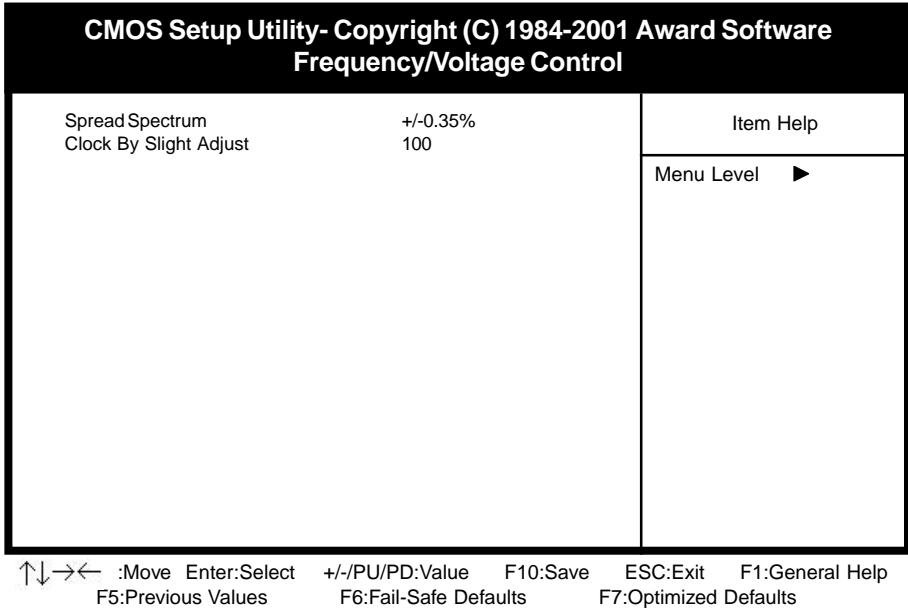

Figure 3-9 Frequency/Voltage Control Screen

A. Spread Spectrum

This function allows you to select a pulse value of the clock generator to lower EMI by spreading the system frequency spectrum. When the system clock generator pulses, the extreme values of the pulse generate excess EMI. Enabling pulse spectrum spread modulation changes the extreme values from spikes to flat curves, thus reducing EMI. This benefit may in some cases be outweighed by problems with timing-critical devices, such as a clock-sensitive SCSI device.
BX

C. Clock By Slight Adjust

This field allows you to select a subtle speed of the CPU Front Side Bus for overclocking possibility.

3-9 Load Fail-Safe Defaults

Load Fail-Safe Defaults loads the default BIOS values directly from the CMOS Setup Utility menu (Figure3-1). If the stored record created by the setup program becomes corrupted and therefore unusable, these defaults will be loaded automatically when you turn on the computer.

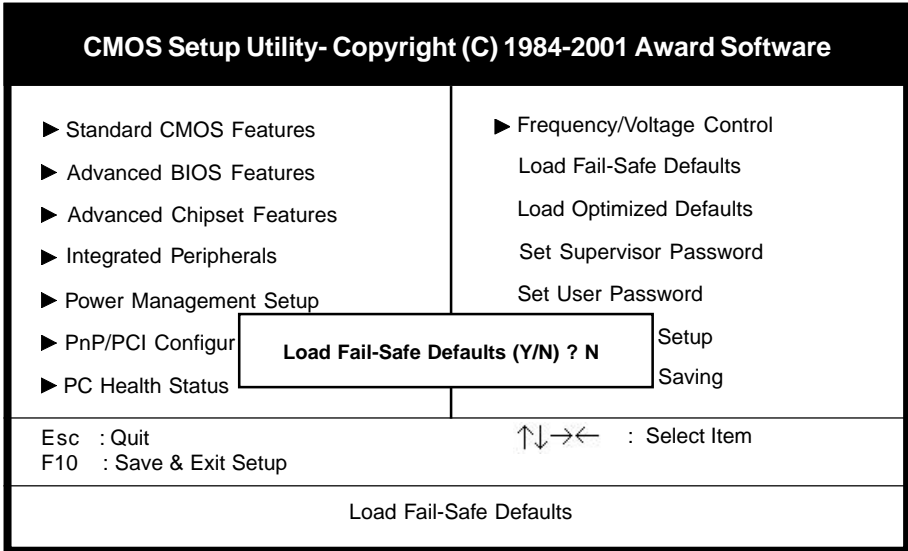

Figure 3-10 Load Fail-Safe Defaults Screen

3-10 Load Optimized Defaults

Load Optimized Defaults loads the default system values directly from the CMOS Setup Utility menu (Figure3-1). If the stored record created by the setup program becomes corrupted and therefore unusable, these defaults will be loaded automatically when you turn on the computer.

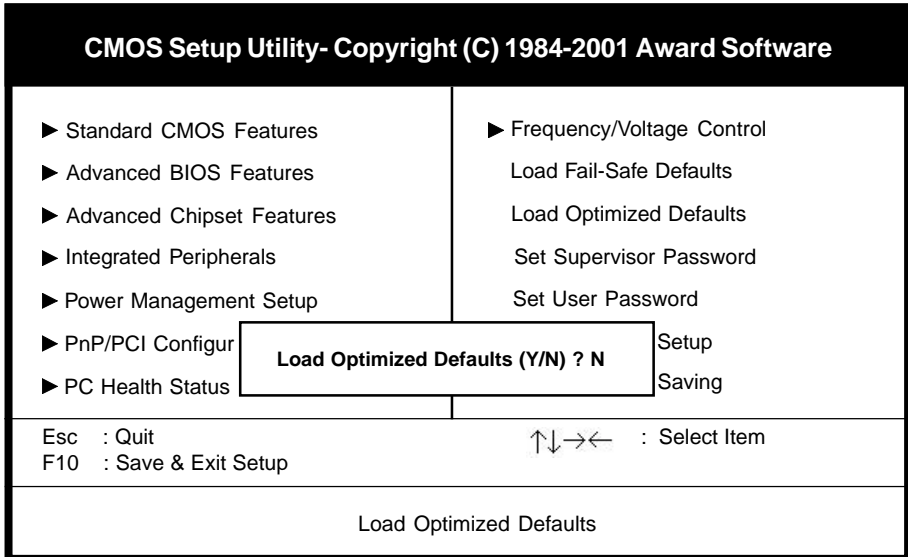

Figure 3-11 Load Optimized Defaults Screen

3-11 Supervisor Password & User Password Setting

There are four different variables that control password settings. The first two are located under the Security Option function in BIOS Features Setup Menu (Figure 3-1). When the Security Option function is set to Setup, a password is required to enter BIOS and change BIOS settings. When the Security Option function is set to System, a password is required to enter both BIOS and the computer's operating system (for example Windows 98) found on the boot drive. This is shown in Figures 3-12 and 3-13.

The third and fourth variables are user password and supervisor password selected in BIOS (Figure 3-1). The main purpose of separating user and supervisor is to allow only the supervisor to have control over the settings in BIOS. The user, on the other hand, is only allowed to access the computer's operating system and change the user password in BIOS (See Figure 3-13). Note that when there is no supervisor password set, the user password controls access to all BIOS settings (See Figure 3-12 below).

A. Set Either Supervisor Password or User Password

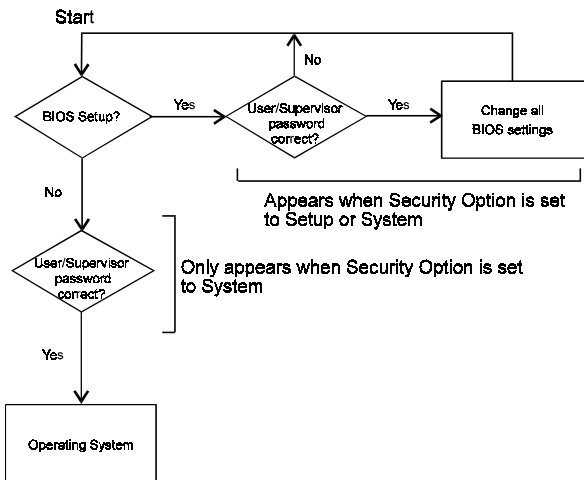

Figure 3-12 Set Either Supervisor or User Password

B. Set Both Supervisor Password and User Password

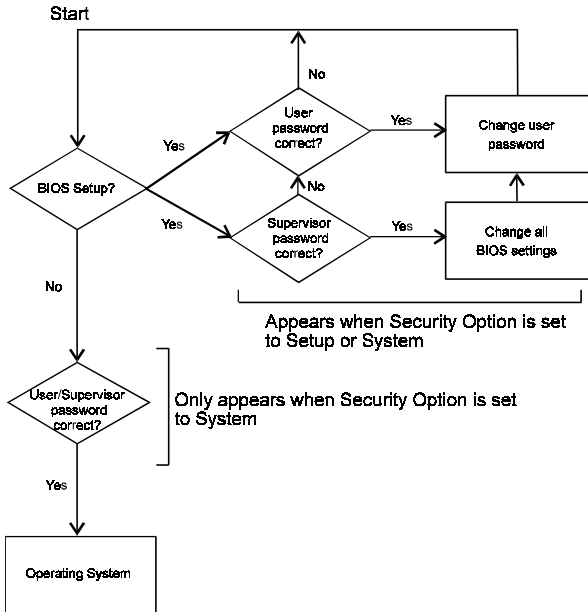

Figure 3-13 Set Both Supervisor and User Password

3-12 Save and Exit Setup

If you select this and type Y (for yes) followed by the [Enter] key, the values entered in the setup utilities will be recorded in the CMOS memory of the BIOS chip.

3-13 Exit Without Saving

Selecting this option and pressing Y followed by the [Enter] key lets you exit the Setup program without recording any new values or changing old ones.

Memo

Brief Software Driver Guide

The Mainboard Software Guide is found on the CD-ROM that is enclosed with your mainboard and is a PDF file which must be viewed with Adobe's freeware called Acrobat® Reader. The Acrobat Reader software is also included on the same CD-ROM. See the Readme.txt file in the CD-ROM's root directory for installation instructions of the Acrobat Reader. The Mainboard software guide discusses the following items:

The following items are discussed in the TXT or PDF files:

- Bus Master/PIO IDE Driver Installation*
- USB Driver Installation*
- Removing the Exclamation and/or Question Marks From the Windows 95 Device Manager Menu*
- Updating Your System BIOS*
- Installing and Using a Desktop Management Interface (DMI) Utility for DOS*
- Sound Driver and Utility Installation*
- VGA AGP drivers for Win9x, NT4.0, Win2000*



The DMI utility is a DOS utility, operating under Windows or other operating system might cause damage to the BIOS.



Memo

Appendix I

On Board I/O Addresses & IRQ Maps

System Resource	IRQ	I/O Address
1. Timer	IRQ0	040, 043
2. Keyboard	IRQ1	060, 064
3. Programmable INT	IRQ2	0020, 0021, 00A0, 00A1
4. COM2(B)	IRQ3	2F8, 2FF
5. COM1(A)	IRQ4	3F8, 3FF
6. Floppy	IRQ6	3F0, 3F7
7. LPT1	IRQ7	378, 37F
8. Real Time Clock	IRQ8	070, 071
9. PS/2 Mouse	IRQ12	060, 064
10. Math coprocessor	IRQ13	0F0, 0FF
11. IDE 1	IRQ14	1F0, 1F7
12. IDE 2	IRQ15	170, 177

✎ **IRQ 5, 9, 10 and 11 are available for interface cards.**



Memo

Embedded Flash Utility

This mainboard is equipped with an Erasable Flash ROM and an Embedded Flash Utility which allows the user to update the BIOS to a newer version. Embedded Flash Utility eases BIOS upgrade and eliminate the compatibility issue between different Flash ROM type and version of Flash utility.

Update Your System BIOS

1. Start computer, upon post, press ALT+F2 Keys to enter AWDFLASH setup.
2. Insert the floppy disk with the latest BIOS file into the floppy drive A(or B) and then press Enter to start programming.

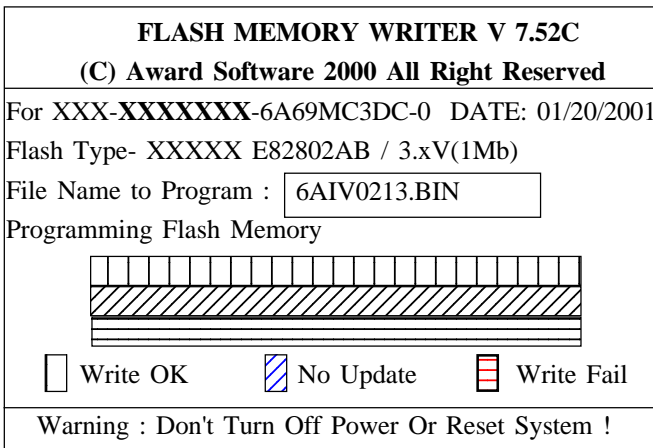

Sample of Programing Flash Memory Screen

3. When finished, the system will automatically restart.

Note:

- ✎ Flash BIOS Protection must be set to Disabled in the Advance Chipset Feature from the CMOS Setup Utility menu. See Chapter 3.
- ✎ Don't turn off or restart your system during programming process.
- ✎ Make sure that your floppy diskette have only one BIN file to avoid confusion.

Memo

HDD Instant Recovery Utility

This mainboard is equipped with HDD Instant Recovery utility embedded in the BIOS ROM. The feature is an option which allows the user to install or not. HDD Instant Recovery utility is a Pre-O.S. backup technology that provides backup before any OS is being activated. Just one press on the Hotkey, HDD Instant Recovery can revive your system even if your O.S. crashed or not working properly.

□ HDD Instant Recovery Concept

HDD IR will save your vital O.S. and application software in a hidden space inside the same hard drive. Since the backup file occupies some space in the hidden directory, the displayed disk space will be reduced. HDD IR will backup your system either with the Smart or Equivalent Backup depends on your O.S. type.

Smart Backup (FAT16/32 format i.e. Win 95/98 O.S.)

- Backup space is the actual system space used.

Equivalent Backup (NTFS format i.e. Windows 2000/NT.)

- Backup space equivalent to the drive space where the O.S. located.

□ Utility Installation

1. Enable the HDD Instant Recovery in the BIOS Features setup from the CMOS Setup Utility menu. Save and exit to reboot.
2. Upon system boot up, the HDD Instant Recovery Utility will be shown on the screen. Selet **Install** and press Enter key to read the instruction.
3. Press **F8** key to continue, you will be prompt to confirmed to keep original data.
4. Type **Y** and press Enter and wait for the installation process to finish and the system will automatically reboot.

HDD Instant Recovery Utility

<Alt-F1>: Backup System

<Alt-F2>: Disk Information

<Alt-F3>: Restore System

<Alt-F4>: Defragmenter

<Alt-F5>: Hard Disk Copy

<Alt-F6>: Uninstall

HDD Instant Recovery Utility Setup screen

□ Backup System

Smart Backup

1. Upon system boot up, the HDD Instant Recovery Utility will be shown on the screen. Selet Backup System by pressing **Alt+F1** key.
2. Select your hard drive to backup.
3. Wait for the backup process to finish and the system will automatically reboot.

Equivalent Backup

 Still under evaluation testing for future Windows 2000/NT supports.

□ Disk Information

1. Upon system boot up, the HDD Instant Recovery Utility will be shown on the screen. Select Disk Information by pressing **Alt+F2** key to view Disk Info.

□ Restore System

1. Upon system boot up, the HDD Instant Recovery Utility will be shown on the screen. Selet Restore System by pressing **Alt+F3** key.
2. You will be prompt to confirmed restore drive. Type **Y** and press **Enter** key.
3. Wait for the backup process to finish and the system will automatically reboot.

□ Defragmenter

1. Upon system boot up, the HDD Instant Recovery Utility will be shown on the screen. Selet Defragmenter by pressing **Alt+F4** key.
2. You will be prompt to confirmed defragment your drive. Type **Y** and press **Enter** key.
3. Wait for the defrgmentation process to finish and the system will automatically reboot.

□ Hard Disk Copy

1. Upon system boot up, the HDD Instant Recovery Utility will be shown on the screen. Selet Hard Disk Copy by pressing **Alt+F5** key.
2. Select which hard drive to backup.(Copy 1 to 2 or 2 to 1 or 1 to 2 3 4)
3. Wait for the hard disk copy process to finish and the system will auto reboot.

□ Uninstall

1. Upon system boot up, the HDD Instant Recovery Utility will be shown on the screen. Seletc uninstall by pressing **Alt+F6** key.
2. You will be prompt to confirmed uninstall. Type **Y** and press **Enter** key.
3. Wait for the uninstalling process to finish and press any key to reboot



This function does not support Multi-Booting management utility like System Commander, etc.



Always uninstall this function before you format or partition the hard disk for other usage.