



T h e S o u l O f C o m p u t e r T e c h n o l o g y

# Mainboard

---

**SL-65ME-T/65ME+-T  
User Manual V1.0**

# NOTICE

<b>Product Model</b>	<b>: SL-65ME-T/ME+-T</b>
<b>Manual Revision</b>	<b>: V1.0</b>
<b>Release Date</b>	<b>: October 2001</b>

**T**his User's Guide & Technical Reference is to help system manufacturers and end-users set up and install the mainboard. Every effort has been made to ensure that the information in this manual is accurate. Soltek Computer Inc. is not responsible for printing or clerical errors. Information in this document is subject to change without notice and does not represent a commitment on the part of Soltek Computer Inc.

No part of this manual may be reproduced, transmitted, translated into any language in any form or by any means, electronic or mechanical, including photocopying and recording, for any purpose without the express written permission of Soltek Computer Inc.

Companies and products mentioned in this manual are for identification purpose only. Product names appearing in this manual may or may not be registered trademarks or copyrights of their respective companies.

Soltek Computer inc. provides this manual "As is" without warranty of any kind, either express or implied, including but not limited to the implied warranties or conditions of merchantability or fitness for a particular purpose. In no event shall Soltek computer inc. be liable for any loss or profits, loss of business, loss of use or data, interruption of business, or for indirect, special, incidental, or consequential damages of any kind, even if Soltek computer inc. has been advised of the possibility of such damages arising from any defect or error in this manual or product.

**Copyright © 2001 Soltek Computer Inc. All Rights Reserved.**

- Intel, Celeron, Pentium II, Pentium III are trademarks of Intel Corporation.
- Intel 82815 Graphic Memory Controller Hub(GMCH), 82801 I/O Controller Hub(ICH) are trademark of Intel Corporation.

# **SOLTEK AROUND THE WORLD**

## **SOLTEK COMPUTER INC.**

Address : 7F, No. 306-3, Ta-Tung Rd, Sec.1, Hsi-Chih, Taipei-Hsien, Taiwan, R.O.C.  
Telephone : 886-2-2642-9060  
Fax : 886-2-2642-9065  
E-mail : [sales@soltek.com.tw](mailto:sales@soltek.com.tw)  
Web site : <http://www.soltek.com.tw>

## **SOLTEK KOREA INC.**

Address : 1002, Chung Jin Bldg. 53-5 Wonhyo-Ro, 3-Ka, Yongsan-Ku Seoul 140-113, Korea  
Telephone : 82-2-32717400  
Fax : 82-2-32717405  
E-mail : [soltek@nuri.net](mailto:soltek@nuri.net)

## **SOUL TECHNOLOGY EUROPE B.V.**

Address : Hongkongstraat 55, 3047 BP Rotterdam. The Netherlands  
Telephone : 31-10-2457492  
Fax : 31-10-2457493  
E-mail : [sales@soultech-europe.com](mailto:sales@soultech-europe.com)  
Web site : <http://www.soultech-europe.com>

# CONTENT

<b>Chapter 1 Introduction .....</b>	<b>8</b>
1-1 Mainboard Specification .....	9
1-1.1 Processor .....	9
1-1.2 Chipset .....	9
1-1.3 AWARD BIOS V6.0, Supporting .....	9
1-1.4 Full Featured Accelerated Graphics Port (AGP) Controller .....	9
1-1.5 Sound Controller .....	9
1-1.6 Integrated SDRAM Controller .....	10
1-1.7 Multi-I/O Function .....	10
1-1.8 Expansion Slots .....	10
1-1.9 Power Management .....	11
1-1.10 Form Factor .....	11
1-1.11 Hardware Monitoring .....	11
1-2 Mainboard Layout .....	12
1-2.1 Mainboard Layout --- 65ME-T .....	12
1-2.2 Mainboard Layout --- 65ME+-T .....	13
1-3 Chipset System Block Diagram .....	14
1-4 Mainboard Specification Table Of 65ME-T & 65ME+-T .....	15
<b>Chapter 2 Hardware Setup .....</b>	<b>17</b>
2-1 CPU Installation .....	18
2-1.1 CPU Frequency .....	18
2-2 Memory Installation .....	19
2-2.1 Supported System Bus And System Memory Bus Frequencies Table .....	20
2-3 HDD/FDD Installation .....	21
2-4 Jumper Setting For Devices On Board .....	23
2-4.1 JP1 Keyboard/Mouse Power On .....	23

2-4.2 JP5/JP6 Bus Clock Select .....	24
2-4.3 BIOS Boot Block Lock (JP16) .....	25
2-4.4 JP21 On-Board Creative Sound Select (For 65ME+-T Only) .....	25
2-4.5 JBAT1/JBAT2 For Clear CMOS DATA .....	26
2-5 Connectors Configurations .....	27
2-5.1 On Board FAN Connector (CPUFA1, AUXFA1, CHAFA1) .....	27
2-5.2 JWOL1 Wake On LAN .....	28
2-5.3 CD-ROM Audio Connector (CD_IN1/CD_IN2) .....	29
2-5.4 TAD1/TV1 Connector .....	30
2-5.5 Thermal Sensor Connector (RT2) .....	31
2-5.6 Complex Header J2&J3 .....	32
2-5.7 ATX Power Supply Connector .....	33
2-5.8 Chassis Panel Connector .....	34
2-5.9 Serial Port Connector .....	35
2-5.10 Smart Card Reader Connector (SCR1) .....	36
2-5.11 Communication And Networking Riser Slot (CNR) .....	37
2-5.12 USB1 Header .....	38
2-5.13 PS/2 Mouse And PS/2 Keyboard .....	38
2-6 IRQ Description .....	39
<b>Chapter 3 Software Setup .....</b>	<b>41</b>
3-1 Open up the Support CD and choose Drivers and Utilities .....	42
3-2 Install “Intel Chipset Software Installation Utility” .....	43
3-3 Install “Intel Application Accelerator” .....	44
3-4 Install “Intel 815 Chipset Graphics Driver” .....	46
3-5 Creative Audio Driver Installation (For 65ME+-T Only) .....	47
3-5.1 To Install Creative Audio Driver .....	47
3-5.2 To Enable The Rear Line Out (For 4 Speakers) .....	48
3-5.3 Identifying Connectors On The Built-in Audio .....	49

3-6 AC'97 Audio Driver Installation (For 65ME-T Only) ..... 50

3-7 Proceed To Hardware Monitor Utility Installation ..... 51

**Chapter 4 BIOS Setup ..... 54**

4-1 What Is BIOS Setup ..... 55

4-2 How To Run BIOS Setup ..... 55

4-3 What Is CMOS ..... 55

4-4 What Is POST ..... 55

4-5 BIOS Upgrade ..... 55

4-5.1 Before Upgrading BIOS ..... 56

4-5.2 Upgrade Process ..... 56

4-6 BIOS Setup --- CMOS Setup Utility ..... 60

4-6.1 CMOS Setup Utility ..... 60

4-6.2 STANDARD CMOS SETUP ..... 61

4-6.3 Advanced BIOS Features ..... 64

4-6.4 Advanced Chipset Features ..... 68

4-6.5 Integrated Peripherals ..... 71

4-6.6 Power Management Setup ..... 76

4-6.7 PNP / PCI Configuration ..... 81

4-6.8 PC Health Status ..... 84

4-6.9 Frequency/Voltage Control ..... 86

4-6.10 Load Optimized Defaults ..... 89

4-6.11 Set Super Visor / User Password ..... 89

4-6.12 Save & Exit Setup ..... 90

4-6.13 Exit Without Saving ..... 90

**Appendix ..... 92**

Appendix-1 Identifying BIOS Version & BIOS Part Number ..... 93

Appendix-2 Identifying Mainboard model Number ..... 94

Appendix-3 Technical Terms ..... 95

## **ITEM LIST CHECKUP**

---

- Mainboard
- Support CD
- User's Manual
- Bundled Bonus Pack CD
- Bundled Bonus Pack Manual
- Temperature Sensor Cable
- ATA66/100 IDE Cable
- RS232 Cable
- FDD Cable

# ***Chapter 1***

## ***Introduction***

---

- This chapter briefly introduces this characteristics of the mainboard. It includes the information regarding the chipset, CPU types, built-in functions and layout. Users will have more ideas about mainboards after reading this chapter.

**This chapter contains the following topics :**

---

- 1-1 Mainboard Specification**
- 1-2 Mainboard Layout**
- 1-3 Chipset Diagram**
- 1-4 Mainboard Specification Table**



## 1-1 Mainboard Specification

### 1-1.1 Processor

- Supporting Intel® FC-PGA Pentium III™ up to 1GHz.
- Supporting Intel® FC-PGA 370 Celeron™ up to 1.1GHz.
- Supporting Intel® FC-PGA2™ processors.
- Supporting VIA® Cyrix III™ up to 800MHz.
- Supporting CPU voltage Auto-Detect circuit.

### 1-1.2 Chipset

- INTEL 82815 B-stepping Graphics and Memory Controller Hub (GMCH) & INTEL 82801BA I/O Controller Hub (ICH2).
- ITE 8712 EC-LPC I/O chip.

### 1-1.3 AWARD BIOS V6.0, Supporting

- Plug & Play V1.0.
- Flash Memory for easy upgrade.
- BIOS writing protection.
- Year 2000 compliant.

### 1-1.4 Full Featured Accelerated Graphics Port (AGP) Controller

- Supporting 64-bit 66/ 100/ 133 MHz System Bus Frequency.
- Providing 1x/ 2x/ 4x AGP controller.
- Integrated 2D & 3D Graphics Engines.
- Integrated H/W Motion Compensation Engine.
- Integrated 24-bit 230 MHz DAC.
- Supporting 133MHz System Memory while running in non-CPC mode.
  - AGP v2.0 compliant.
  - Full 2D H/W Acceleration.
  - 2D Graphics up to 1600 x 1200 in 8-bit Color at 85 Hz Refresh.
  - H/W Motion Compensation Assistance for S/W MPEG2 Decode.
  - Integrated Graphics Memory Controller can be disabled to support an external AGP Card or PCI Graphics card.
  - Provided an AGP Pro Slot which is compatible for AGP 1X/2X/4X mode and AGP In-Line Memory Module (AIMM) up to 4 MB.

### 1-1.5 Sound Controller

- Built-in AC'97 Audio codec (for 65ME-T only).
- Built-in creative CT5880 Audio chip (for 65ME+-T only).

### 1-1.6 Integrated SDRAM Controller

- Providing 3pcs DIMM slots for double-sided DIMMs.
- Supporting 100/133MHz SDRAM spec.
- Supporting total memory from 32MB to 512MB using 32Mb/64Mb/128Mb/256Mb technology.
- Supporting up to 3 double sided DIMMs at 100MHz system memory bus.
- Supporting up to 2 double sided or 3 single sided DIMMs at 133MHz system memory bus.
- Unbuffered , Non-ECC SDRAM supported only.

### 1-1.7 Multi-I/O Function

- Integrated IDE Controller.
- Supporting Ultra ATA100/66, BMIDE and PIO modes Universal Serial Bus connector:
  - USB v1.1 compliant.
  - 2 built-in USB connectors, in addition to one internal USB header which requires a USB cable to support 2 more optional USB ports.
- Two UART's for Complete Serial Ports.
- Dedicated IR connector:
  - Third serial port dedicated to IR function either through the two complete serial ports or the third dedicated port Infrared-IrDA (HPSIR) and ASK (Amplitude Shift Keyed) IR.
- Multi-mode parallel connector supporting:
  - Standard mode, ECP and EPP.
- Floppy Disk connector supporting:
  - One FDD connector with drive swap support .
- Universal Serial Bus connector supporting:
  - USB v1.1 and Intel Universal HCI v1.1 compatible.
  - 2 built-in USB connectors and one USB Header (USB1) which requires an optional USB cable to provide 2 more optional USB ports.
- PS/2 Keyboard connector.
- PS/2 Mouse connector.

### 1-1.8 Expansion Slots

- Five PCI bus Mater slots.
- One AGP 4x mode slot.
- One CNR slot.
- Three DIMM slots.
- One SCR (Smart Card Reader) slot.

### **1-1.9 Power Management**

- ACPI 1.0 compliant (Advanced Configuration and Power Interface).
- APM V1.2 compliant (Legacy power management).
- Supporting POS mode (Power On Suspend).
- System event monitoring with two event classes.
- Supporting PS/2 Keyboard & Mouse power on.
- Supporting Wake On LAN (WOL) & Wake On Modem.
- Supporting real time clock (RTC) with date alarm, month alarm, and century field.

### **1-1.10 Form Factor**

- ATX form factor 4-layer PCB.
- Mainboard size: 30.5cm x 19.0cm.

### **1-1.11 Hardware Monitoring**

- Programmable control, status, to provide monitoring and alarm for flexible desktop management of hardware temperature (software provided in support CD).
- 8 positive voltage statuses monitoring.
- 2 temperatures statuses monitoring.
- 3 Fan-speeds statuses monitoring.

## 1-2 Mainboard Layout

### 1-2.1 Mainboard Layout --- 65ME-T

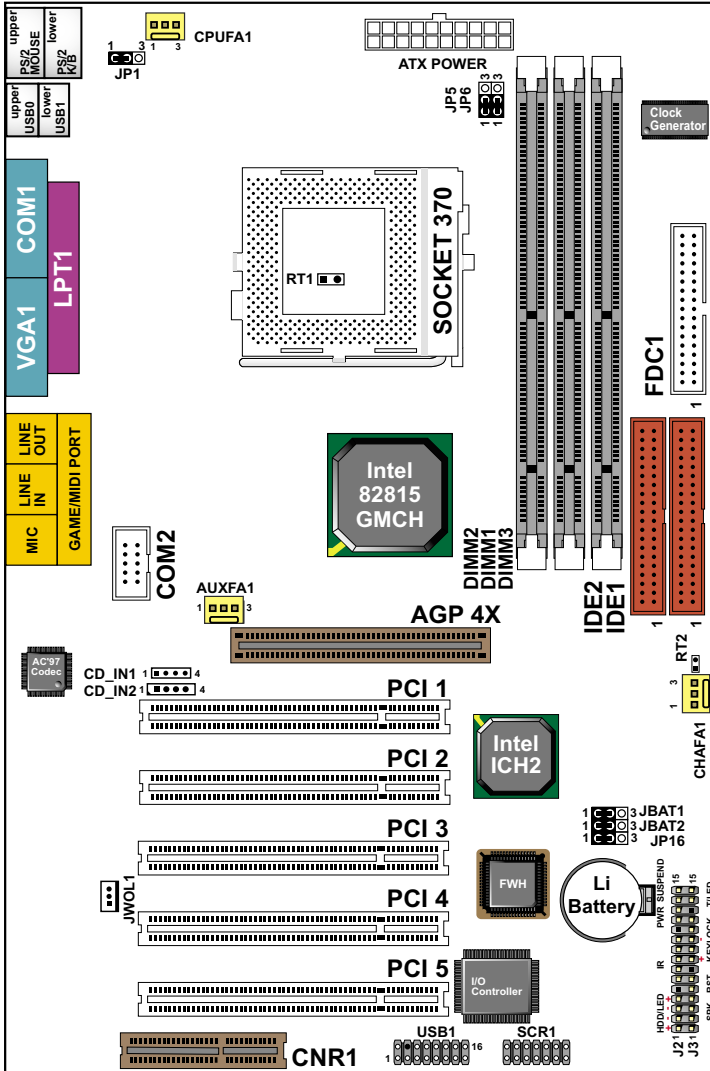

Using non-compliant memory with higher bus clock (over clocking) may severely compromise the integrity of system.

## 1-2.2 Mainboard Layout --- 65ME+-T

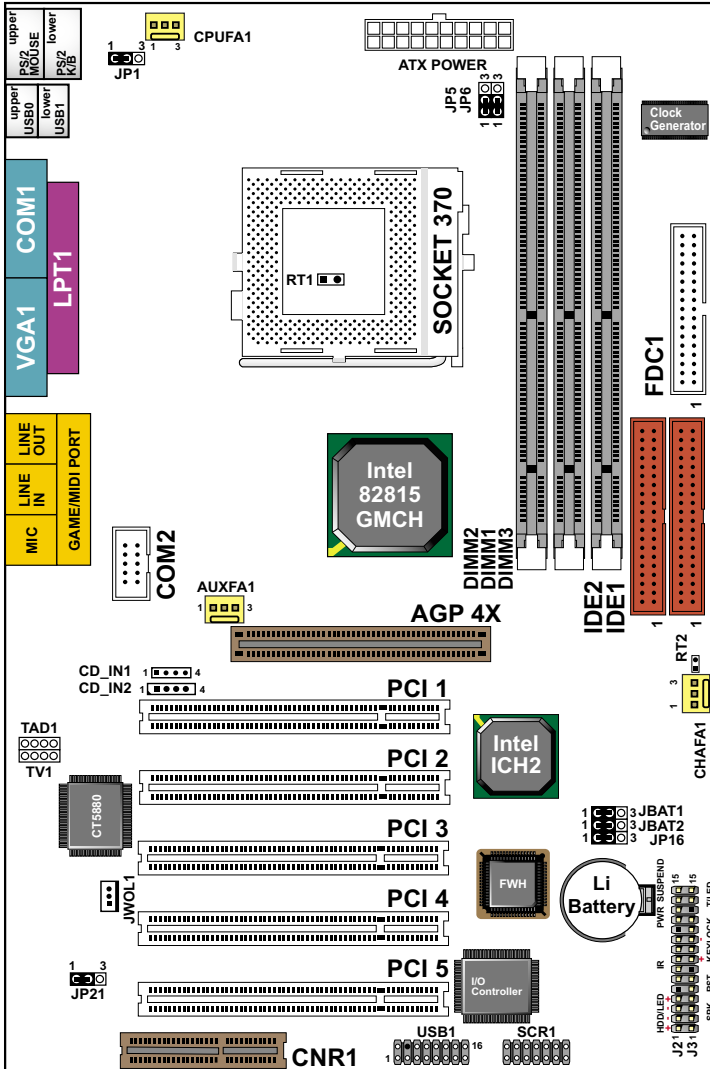

Using non-compliant memory with higher bus clock (over clocking) may severely compromise the integrity of system.

### 1-3 Chipset System Block Diagram

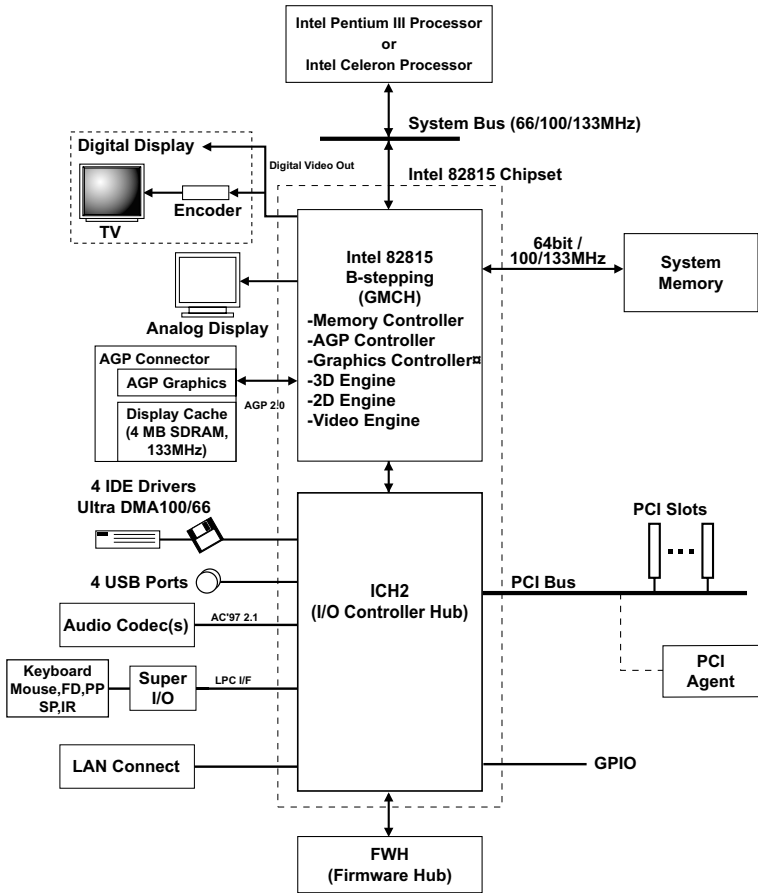

Intel 82815 GMCH Chipset Diagram

## 1-4 Mainboard Specification Table Of 65ME-T &amp; 65ME+-T

Model	65ME-T	65ME+-T
Memory Controller Hub	Intel 82815 B-stepping (GMCH)	
I/O Controller Hub	Intel 82801BA (ICH2)	
LPC I/O Chip	ITE 8712	
Memory	Supports PC133 and PC100 SDRAM up to 512GB 3 DIMM Slots	
AGP Interface	AGP 4X Pro Mode	
Audio	On-Chip AC'97	Creative CT5880
IDE	2 x ATA 66/100 IDE ports	2 x ATA 66/100 IDE ports
I/O	4 x USB ports, 1 x FDD port, 2 x COM ports, 1 x LPT port, 1 IrDA, 1 PS/2 Mouse, 1 PS/2 K/B	
PCI slot	5 PCI Master Slots	
CNR slot	1 x CNR slot	
Smart card reader support	Yes* (Provides a Smart Card Reader connector)	
Hardware Monitoring	Yes	
BIOS writing Protection	Yes	
Keyboard power on function	Yes	
Remark		

**MEMO**

---



## Chapter 2

# Hardware Setup

---

### **ATTENTION !!!**

---

1. Please refer to your processor installation or other documentation attached to your CPU for more detailed installing instruction.
2. Installing a heat sink and cooling fan is necessary for proper heat dissipation from your CPU. Incorrect installation may result in overheating and damage of your CPU.
3. Before changing the setting of CPU Vcore from BIOS program, user **SHOULD** make sure of correct specification both of CPU **CLOCK** and **RATIO**. Incorrect setting may cause damage to your CPU.

---

**This chapter contains the following topics :**

- 2-1 CPU Installation**
- 2-2 Memory Installation**
- 2-3 AGP PRO Installation**
- 2-4 HDD/FDD Installation**
- 2-5 Jumper Setting For Devices On Boards**
- 2-6 Connectors Configuration**

## 2-1 CPU Installation

### **WARNING !!!**

- Make sure that +5V DCV and +3.3 DCV of your power supply are suitable for the processor.
- Any attempt to operate the Celeron or PIII processor without a suitable cooling Fan will damage processor and other component.

- 1** Pull out the lever from the socket, and then raise the lever up to a 90-degree angle.

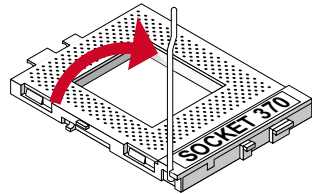

- 2** Take notice of the red circles as shown here. While inserting the CPU into the socket, you can find out there is a definite pin orientation for CPU and socket.

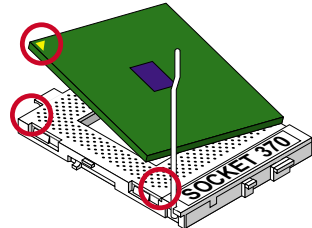

- 3** Make sure that the CPU is placed into the socket tightly. Then lower down the lever to complete the CPU installation.

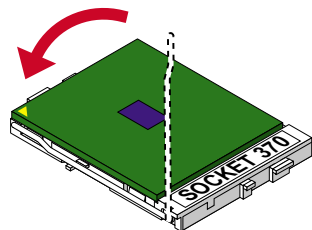

### 2-1.1 CPU Frequency

- The CPU's "**CPU CLOCK RATIO**" and "**CPU HOST/PCI CLOCK**" settings are automatically detected to be default value by BIOS in the "Frequency/ Voltage Control" section.
- We do not suggest and assume the responsibility for any action that changes the CPU default setting such as overclocking. Incorrect **CLOCK RATIO** and **HOST/PCI CLOCK** settings may cause damage to your CPU.

## 2-2 Memory Installation

### **WARNING!!!**

- Make sure to unplug your power supply before adding or removing memory modules or other system components. Failure to do so may cause severe damage to both your mainboard and expansion cards.
- Be careful when inserting or removing DIMM. Forcing a DIMM in or out of a socket improperly may damage the memory module or the socket. Some DIMMs which contain EDO or FPM DRAM are incompatible with the mainboard. The M/B supports 3.3V true SDRAM DIMMs only.

### Installing DIMM

- Make sure you have the correct memory module type for your mainboard.
- Insert the module(s) as shown below, DIMMs have 168-pins and two notches that will be matched by the onboard DIMM socket. Memory modules are installed by inserting them straight into the slot until they “click” in the right place. They only fit in one direction, so do not force them in by a wrong direction.

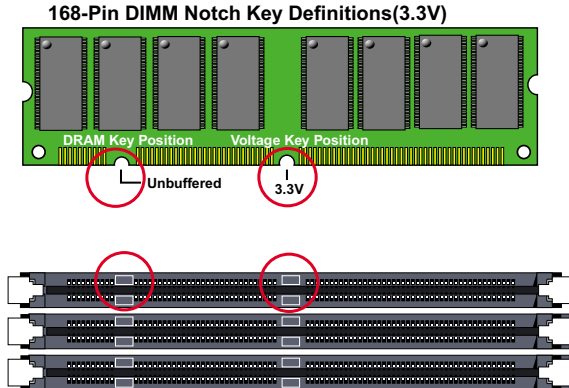

### Removing DIMM

- Press down the holding clips on both sides of a DIMM socket and the module will be released from it.

## 2-2.1 Supported System Bus And System Memory Bus Frequencies Table

- The 82815 B-stepping MCH has a new type of clocking architecture. It has integrated SDRAM buffers that run at either 100 or 133 MHz, independent of the system bus frequency. See table below for supported system bus and system memory bus frequencies of 82815 B-stepping.

Front Side Bus Frequency	System Memory Bus Frequency	AGP Bus Frequency	PCI Bus Frequency	Supported Maximum DIMM numbers
66MHz	100MHz	66MHz	33MHz	3 single sided DIMMs
100MHz	100MHz	66MHz	33MHz	3 single sided DIMMs
133MHz	100MHz	66MHz	33MHz	2 double sided or 3 single sides DIMMs
133MHz	133MHz	66MHz	33MHz	2 double sided or 3 single sides DIMMs

### 2-3 HDD/FDD Installation

- To install HDD (Hard Disk Drive), you may connect the cable's blue connector to the mainboard's primary (IDE1) or secondary (IDE2) connector, and then connect the gray connector to your slave device and the black connector to your master device. If you install two hard disks, you must configure the second drive to Slave mode by setting its jumper accordingly. Please refer to your hard disk documentation for the jumper settings.

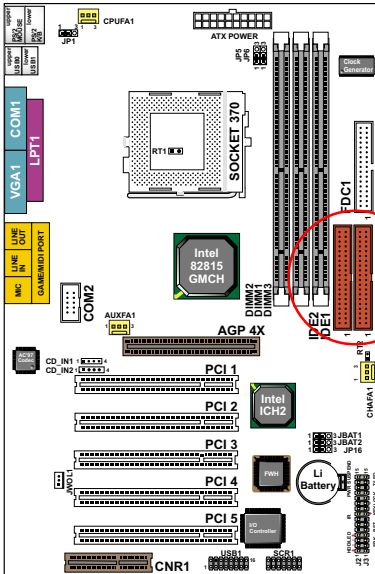

Hard Disk Drive Connector:  
Orient the red line on the  
IDE ribbon cable to Pin1.

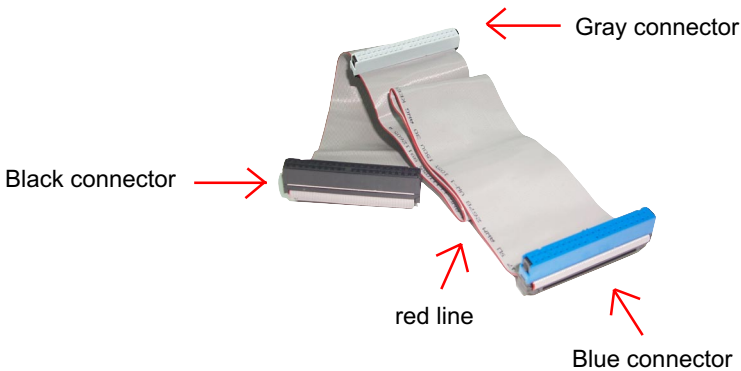

IDE Cable

- To install FDD (Floppy Disk Drive), you may connect the end with single connector to the board , and connect the other end with two plugs to the floppy drives.

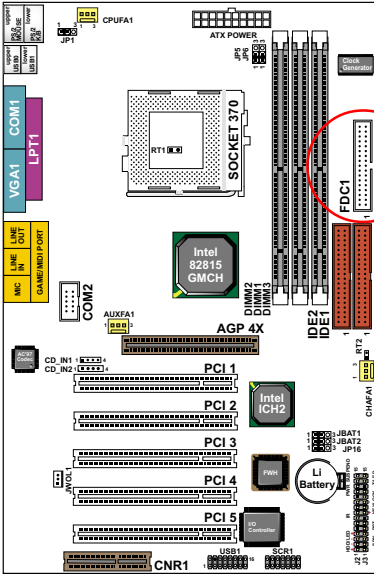

Floppy Disk Drive Connector:  
Orient the red line on the floppy ribbon cable to Pin1.

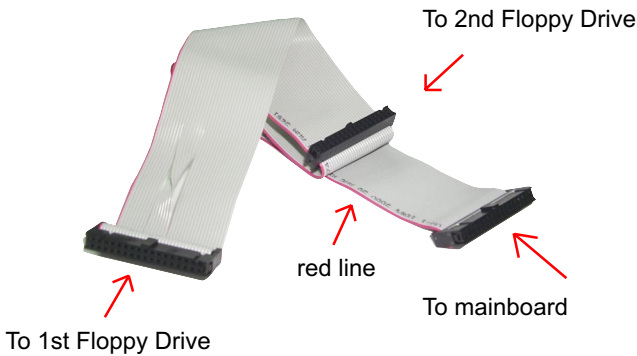

FDD Cable

## 2-4 Jumper Setting For Devices On Board

- The following diagrams show the locations of jumper blocks on the mainboard.

### CAUTION

- Do not remove the jumper when power is on. Always make sure the power is off before changing any jumpers. Otherwise, mainboard could be damaged.
- In diagrams below, all jumper pins covered with black marks stand for closed pins.

### 2-4.1 JP1 Keyboard/Mouse Power On

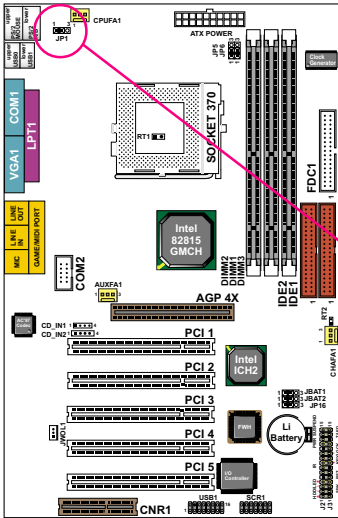

PS/2 Keyboard/Mouse Power On:

Disabled (default)	 1 3 JP1
Enabled	 1 3 JP1

**NOTE:** This function allows you to use PS/2 keyboard or PS/2 mouse to power on your system. The function must be set in conjunction with “Power on function” state in BIOS setup “Integrated peripherals” section.

### 2-4.2 JP5/JP6 Bus Clock Select

JP5/JP6 settings for FSB (Front Side Bus) Frequency Select is a redundancy device designed for professional CPU overclocking only. Since this mainboard is designed with CPU clock auto-detection function, you are recommended to use the JP5/JP6 default setting for a stable system performance. In case of CPU overclocking to higher frequency, these exists high possibility of failure due to the high complexity of components adopted on board. On the other hand, selecting a lower frequency setting for a CPU with higher frequency (e.g. select 100MHz setting for a 133MHz CPU) will also cause system failure.

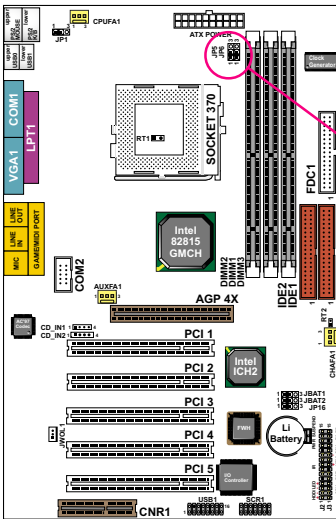

Bus Clock Select:

66MHz / 100MHz / 133MHz Auto Select (default)	
For 100MHz Bus Only	
For 133MHz Bus Only	



### 2-4.3 BIOS Boot Block Lock (JP16)

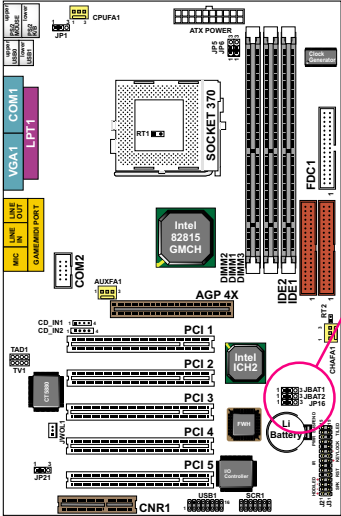

BIOS Boot Block Lock:

Locked	<table border="1"> <tr> <td>1</td> <td>3</td> </tr> <tr> <td><input checked="" type="checkbox"/></td> <td><input checked="" type="checkbox"/></td> </tr> </table> <p>JP16</p>	1	3	<input checked="" type="checkbox"/>	<input checked="" type="checkbox"/>
1	3				
<input checked="" type="checkbox"/>	<input checked="" type="checkbox"/>				
Unlocked (default)	<table border="1"> <tr> <td>1</td> <td>3</td> </tr> <tr> <td><input checked="" type="checkbox"/></td> <td><input type="checkbox"/></td> </tr> </table> <p>JP16</p>	1	3	<input checked="" type="checkbox"/>	<input type="checkbox"/>
1	3				
<input checked="" type="checkbox"/>	<input type="checkbox"/>				

*NOTE: When upgrading new BIOS version for 65ME-T/ME+-T, JP16 must be on 1-2 (unlocked).*

### 2-4.4 JP21 On-Board Creative Sound Select (For 65ME+-T Only)

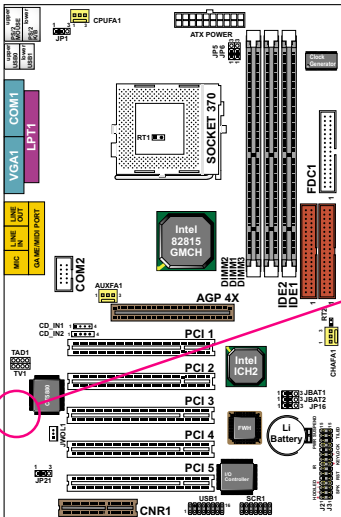

On-Board Creative Sound Select:

Enabled (default)	<table border="1"> <tr> <td>1</td> <td>3</td> </tr> <tr> <td><input checked="" type="checkbox"/></td> <td><input type="checkbox"/></td> </tr> </table> <p>JP21</p>	1	3	<input checked="" type="checkbox"/>	<input type="checkbox"/>
1	3				
<input checked="" type="checkbox"/>	<input type="checkbox"/>				
Disabled	<table border="1"> <tr> <td>1</td> <td>3</td> </tr> <tr> <td><input type="checkbox"/></td> <td><input checked="" type="checkbox"/></td> </tr> </table> <p>JP21</p>	1	3	<input type="checkbox"/>	<input checked="" type="checkbox"/>
1	3				
<input type="checkbox"/>	<input checked="" type="checkbox"/>				

### 2-4.5 JBAT1/JBAT2 For Clear CMOS DATA

A battery should be used to supply the power for the CMOS RAM to retain the mainboard configuration.

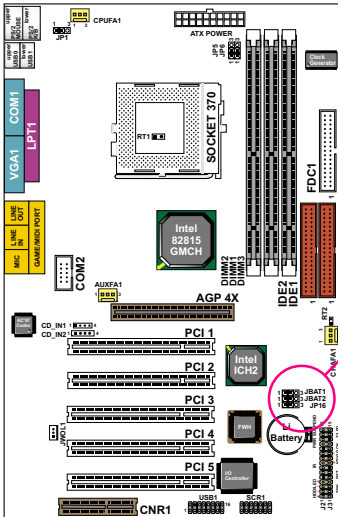

#### JBAT1/JBAT2 For Clear CMOS DATA:

Clear CMOS Data	1	3	JBAT1 JBAT2
	○	○	
Retain Data (default)	1	3	JBAT1 JBAT2
	○	○	

**NOTE:** You can clear CMOS by 2-3 pin when the system is POWER OFF. Then, return to 1-2 pin position (default). It may damage the mainboard if clearing the CMOS with POWER ON. Unplugging the power cord from power supply before clearing CMOS will be a safest bet for user.

## 2-5 Connectors Configurations

- This section list out all connectors configurations for users' reference.

### 2-5.1 On Board FAN Connector (CPUFA1, AUXFA1, CHAFA1)

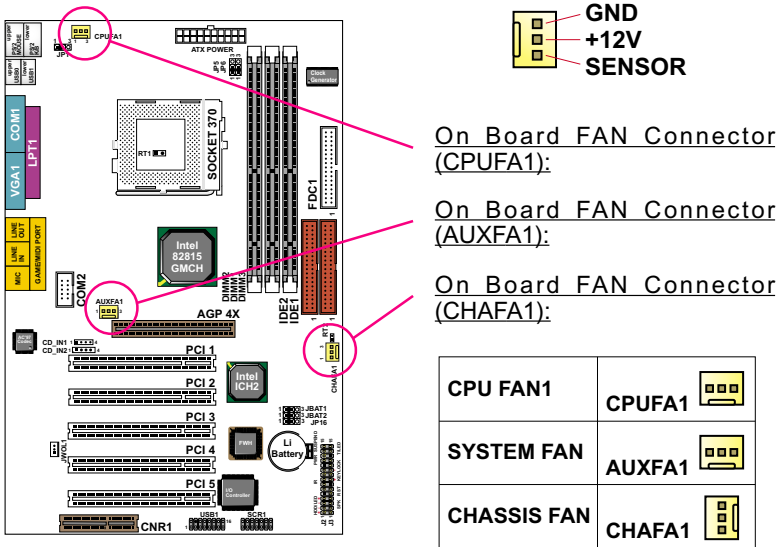

These fan connectors support CPU/System/chassis cooling fan with +12V. When connecting wire to FAN connectors, users should pay attention that the red wire is for the positive current and should be connected to pin +12V, and the black wire is Ground and should be connected to pin GND. If your mainboard has Hardware Monitor chipset on-board, you must use a specially designed fan with speed sensor to take advantage of this function.

For fans with speed sensors, each rotation of the fan blades will send out 2 electric pulses, by which System Hardware Monitor will work out the fan rotation speed by counting the pulses.

**NOTE:**

- Always consult vendor for proper CPU cooling fan.
- CPU FAN supports the FAN control. You can install PC Alert utility. This will automatically control the CPU FAN speed according to the actual CPU temperature.
- We use 3 "Yellow" fan connectors to mark that they support fan speed sensor function.

## 2-5.2 JWOL1 Wake On LAN

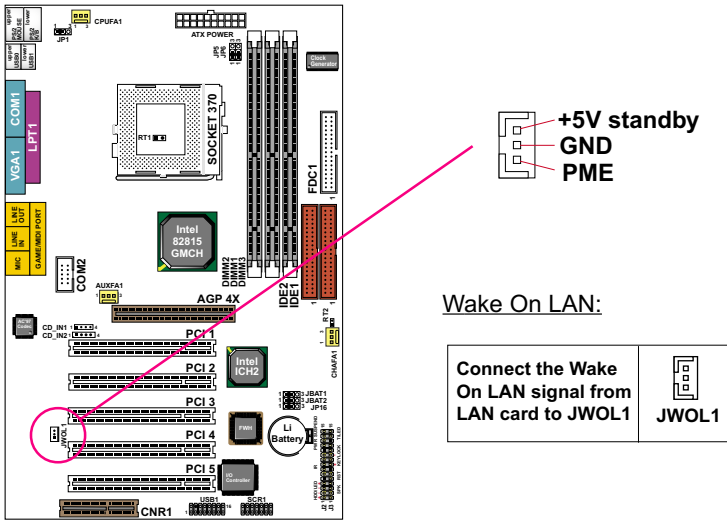

This connector is connected to the LAN card with a Wake On LAN output. The connector powers up the system when it receives a wake-up packet or signal through the LAN card.

This feature requires that Wake On LAN feature is enabled in the **“Power Management Setup”** of BIOS setting and that your system must be on an ATX power supply with at least 720mA / +5V standby power.

### 2-5.3 CD-ROM Audio Connector (CD\_IN1/CD\_IN2)

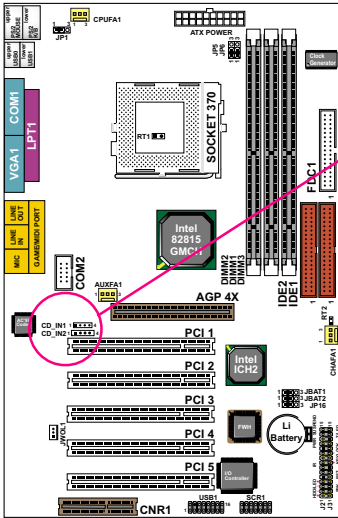

CD-ROM Audio Connector:

PIN NO.	CD_IN1	CD_IN2
PIN 1	GND	Left Channel
PIN 2	Left Channel	GND
PIN 3	GND	GND
PIN 4	Right Channel	Right Channel

### 2-5.4 TAD1/TV1 Connector

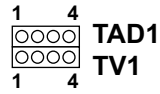
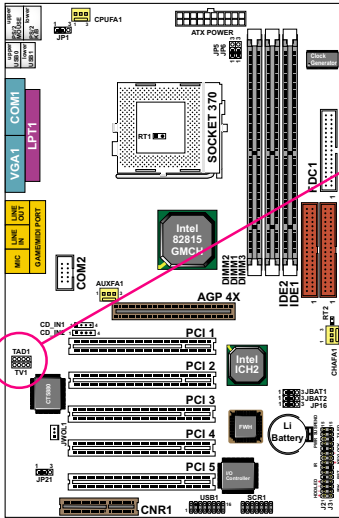

TAD1/TV1 Connector:

PIN NO.	TAD1	TV1
PIN 1	PHONE	TV_L CHANNEL
PIN 2	GND	GND
PIN 3	GND	GND
PIN 4	TADOUT	TV_R CHANNEL

**TAD1** : Telephone Answering Device / Modem connector.  
 Connects a voice modem to transmit and receive audio signals.  
**TV1** : TV Tuner connector.  
 Connects a TV card or second CD-ROM drive.  
 TAD1 / TV1 is only for **65ME+-T**

## 2-5.5 Thermal Sensor Connector (RT2)

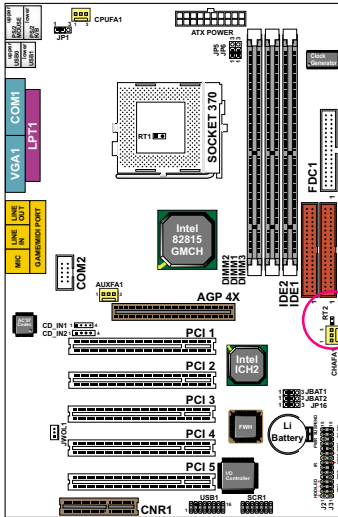

Thermal Sensor Connector (RT2):

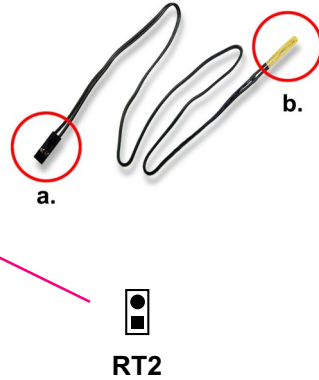

We provide a thermal cable in the mainboard package. This thermal cable is to monitor device which will generates a lot of heat, such as HDD, Graphics card etc. Please connect one end of the thermal cable (A) to mainboard RT2 header, and tape another end of thermal cable (B) on to the device which you want to monitor. After you have finish the thermal cable installation, you will **see the detected temperature in BIOS setup or Hardware monitor utility.**

## 2-5.6 Complex Header J2&J3

- This complex Header consists of 10 connectors providing various supports:

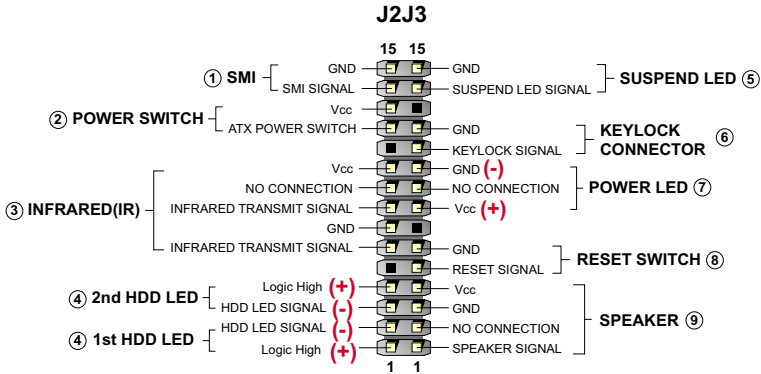

### 1. J2 SMI Connector (System Management Interrupt):

**CONNECTION:** This 2-pin connector is connected to the case-mounted Suspend Switch.

**FUNCTION :** Manually placing the system into a Suspend mode or “Green” mode.

### 2. J2 Power Switch Connector:

**CONNECTION:** Connected to a momentary button or switch.

**FUNCTION :** Manually switching the system between “On” and “Soft Off”. Pressing the momentary button for more than 4 seconds will also turn the system off.

### 3. J2 IR Connector (Infrared Connector):

**CONNECTION:** Connected to Connector IR on board.

**FUNCTION :** Supporting wireless transmitting and receiving module on board.

### 4. J2 1st HDD LED Connector / J2 2nd HDD LED Connector:

**CONNECTION:** Connected to HDD LED.

**FUNCTION :** To supply power to HDD LED.

### 5. J3 Suspend LED Connector:

**CONNECTION:** Connected to Suspend indicator.

**FUNCTION :** To supply power to “Suspend indicator”.



**6. J3 Keylock Connector:**

**CONNECTION:** Connected to keylock switch.

**FUNCTION :** To lock keyboard for security purpose.

**7. J3 Power LED Connector:**

**CONNECTION:** Connected to System Power LED.

**FUNCTION :** To supply power to “System Power LED”.

**8. J3 Reset Switch Connector:**

**CONNECTION:** Connected to the case-mounted “Reset Switch”.

**FUNCTION :** To supply power to “Reset Switch” and support system reboot function.

**9. J3 Speaker Connector:**

**CONNECTION:** Connected to the case-mounted Speaker.

**FUNCTION :** To supply power to the case-mounted Speaker.

**2-5.7 ATX Power Supply Connector**

- This connector connects to an ATX power supply. The plug from the power supply should only be inserted to ATX Power connector in a specific orientation. Find the proper orientation and push it down firmly to make sure that all pins are aligned.
- Your power supply should support at least 10mA on the 5V standby voltage. It may cause difficulty to turn on the system power if the power supply does not support the load.
- **For Wake On LAN function, the power supply should support at least 720mA current.**

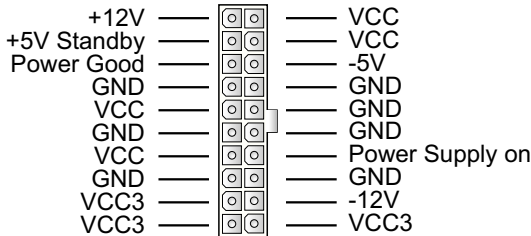

## 2-5.8 Chassis Panel Connector

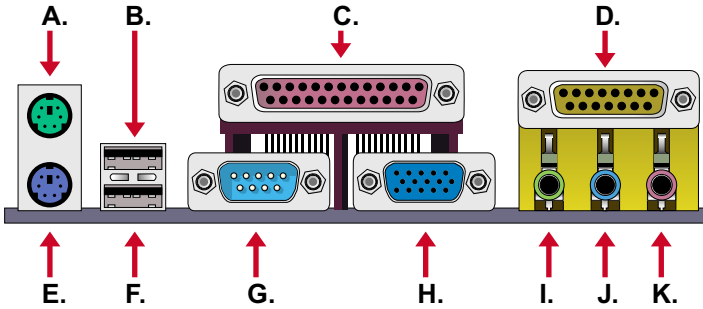

- A : PS/2 MOUSE PORT
- B : USB 0 PORT
- C : LPT1 PORT
- D : GAME/MIDI PORT
- E : PS/2 KEYBOARD PORT
- F : USB 1 PORT
- G : COM1 PORT
- H : VGA PORT
- I : LINE OUT/ SPEAKER OUT PORT
- J : LINE IN (or second speaker out  
for 65ME+ only)
- K : MICROPHONE

### 2-5.9 Serial Port Connector

- One serial port is ready for a mouse or other serial devices. A second serial port is available using a serial port bracket connected from the mainboard to an expansion slot opening.

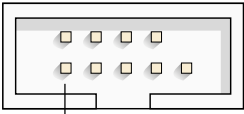
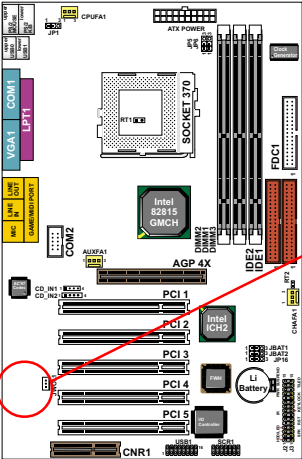

PIN1

Serial Port Connectors:  
Orient the red markings on the floppy ribbon cable to PIN1.

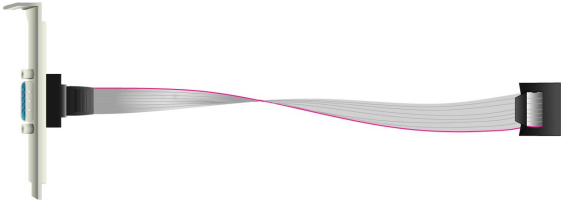

RS232 cable

### 2-5.10 Smart Card Reader Connector (SCR1)

- The connector “SCR1” allows you to use Smart Card Reader. It is compliant with Personal Computer Smart Card (PC/SC) working group standard and smart card (ISO 7816) protocols.

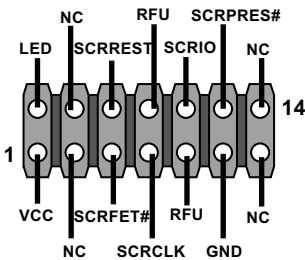
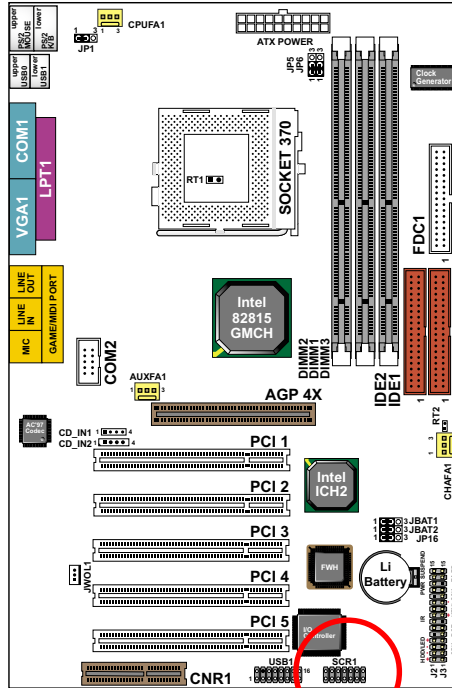

**SCR1 pin assignment**

### 2-5.11 Communication And Networking Riser Slot (CNR)

- This connector allows you to use network, modem or audio riser cards.

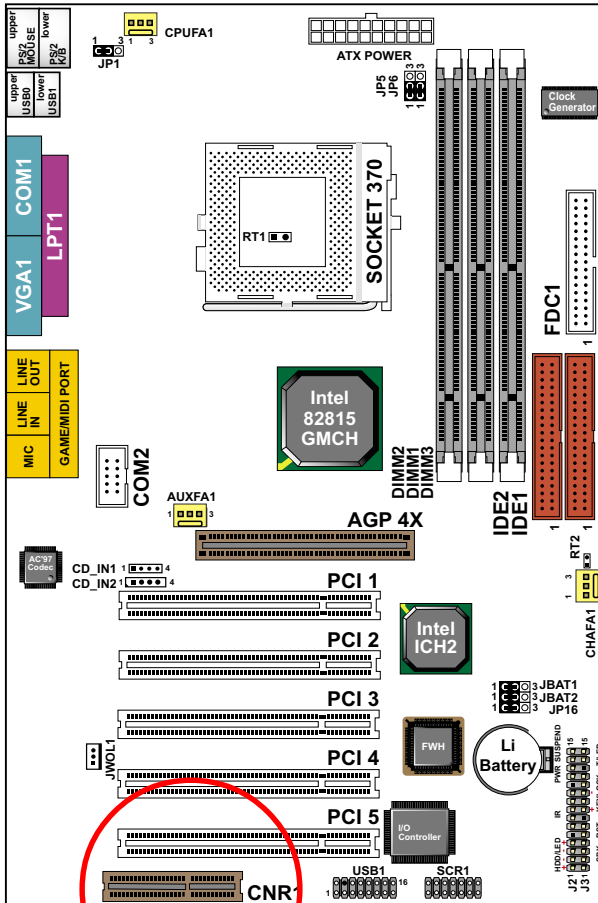

CNR slot

**Note:**

1. If only modem CNR is installed, the modem CNR must be set as primary.
2. Only one LAN CNR can be supported.
3. The audio CNR must be set as secondary, if on-chip AC 97 is enabled.
4. CNR devices are not provided with this mainboard.

### 2-5.12 USB1 Header

- This header is for connecting the additional USB cable to provides you two additional USB ports. User can order the additional USB cable from your mainboard dealer and vender.

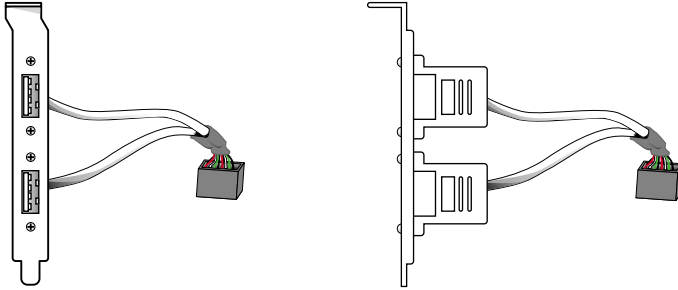

**Additional USB Cable (Optional)**

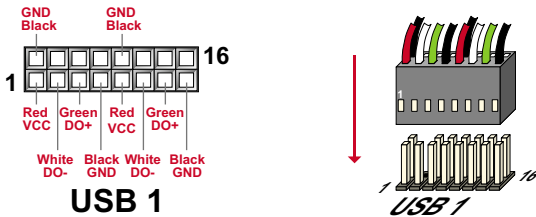

- When plugging the USB cable into USB1 Header, users must make sure the red wire is connected to the first pin.

### 2-5.13 PS/2 Mouse And PS/2 Keyboard

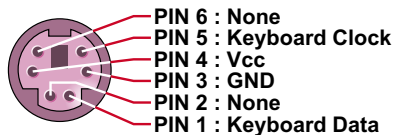
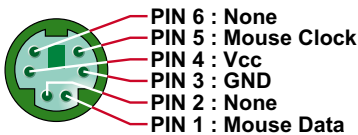

## 2-6 IRQ Description

IRQ	Function Description	Priority
IRQ 0	System Timer	1
IRQ 1	Keyboard Controller	2
IRQ 2	Programmable Interrupt	N/A
IRQ 3	Serial Port (COM 2)	11
IRQ 4	Serial Port (COM 1)	12
IRQ 5		13
IRQ 6	Floppy Disk Controller	14
IRQ 7	Parallel Port (LPT1)	15
IRQ 8	Real Time Clock (RTC)	3
IRQ 9		4
IRQ 10		5
IRQ 11		6
IRQ 12	PS/2 Mouse Port	7
IRQ 13	Coprocessor	8
IRQ 14	Primary IDE Channel	9
IRQ 15	Secondary IDE Channel	10

- Both ISA and PCI expansion cards may require IRQs. System IRQs are available to cards installed in the ISA expansion bus first, then any remaining IRQs are available to PCI cards. Currently, there are two types of ISA cards.
- The original ISA expansion card design, now referred to as “Legacy” ISA card, requires you to configure the card’s jumpers manually and then install it in any available slot on the ISA bus. To see a map of your used and free IRQs in Windows 98, the *Control Panel* in *My Computer*, contains a *System* icon, which gives you a *Device Manager* tab. Double-Clicking on a specific hardware device gives you a *Resources* tab which shows the Interrupt number and address. Double-Clicking *Computers* to see all the interrupts and addresses for your system. Make sure that no more than two devices use the same IRQ or your computer will result problems when those two devices are used at the same time.

**MEMO**

---



# Chapter 3

## Software Setup

---

### Drivers, Utilities and Software Installation

- Support CD:  
This series of mainboards will always be shipped with a Support CD which contains those necessary driver files, Application Softwares and some helpful utilities. It is a user-friendly, auto-run CD which will open itself up in a CD-ROM automatically.
- Contents of Support CD:  
For 65ME-T and 65ME+-T, user should be able to find in the Supported CD the following drivers and utilities supported by Intel 845 Chipset:
  1. INF Utility (Intel Chipset Software Installation Utility);
  2. Intel Application Accelerator ( IAA );
  3. Intel 815 Chipset Graphics Driver;
  4. Creative Audio drivers;
  5. AC'97 Audio Drivers;
  6. Hardware Monitor Utility.

This chapter is devoted to describing the installations of all these essential drivers and utilities on Windows 9X, Windows ME, Windows 2000 and Windows XP. The installation procedures for all these operating systems are all programmed into an auto-run mode. What users have to do is to read and follow the pop-up instructions to carry out the installation. We therefore take the installation on Windows 98 as the general illustration hereby. The priority of drivers to be installed should also be noted.

---

#### **This chapter contains the following topics :**

- 3-1 Open up the Support CD and choose Drivers and Utilities**
- 3-2 Intel Chipset Software Installation Utility ( INF Utility )**
- 3-3 Intel Application Accelerator ( IAA )**
- 3-4 Intel 815 Chipset Graphics Driver Installation**
- 3-5 Creative Audio Drivers Installation (For 65ME+-T Only)**
- 3-6 AC'97 Audio Drivers Installation (For 65ME-T Only)**
- 3-7 Hardware Monitor Utility**

### 3-1 Open up the Support CD and choose Drivers and Utilities

**1** Please put the Support CD enclosed in your mainboard package into the CD-ROM drive. In a few seconds, the Main Menu will automatically appear, displaying the contents to be installed for this series:

- Intel Chipset Software Installation Utility (INF Utility)
- Intel Application Accelerator (IAA)
- Intel 815 Chipset Graphics Driver Installation
- Creative Audio Drivers
- AC'97 Audio Drivers
- Hardware Monitor Utility
- Install Acrobat Reader
- Browse CD-ROM
- Exit

**2** In case your system does not open the Support CD automatically, please click to the following path to enter the Main Installation Menu:

D:\Autorun.exe (assuming that your CD-ROM Drive is Drive D)

**3** Users are recommended to install all the drivers and utilities at a time, though they can be installed separately. Also, we should take "Intel Chipset Software installation Utility" as first installation priority to optimize the Intel system. From next section, we provide detailed descriptions of all these installations with graphical illustrations.

## 3-2 Install “Intel Chipset Software Installation Utility”

1 Following the procedures of opening the Support CD, click to “ Install Intel Chipset software installation Utility” to proceed.

2 The Intel Service Pack Install Shield Wizard will pop up to guide you to the Intel Service pack installation. Press “Next” button to continue.

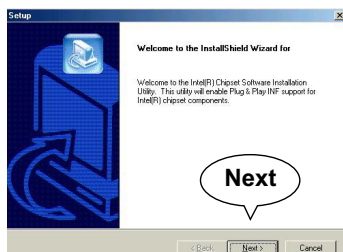

3 “Intel Software License Agreement” screen will appear, please click the “Yes” button to agree with the Licence Agreement and continue.

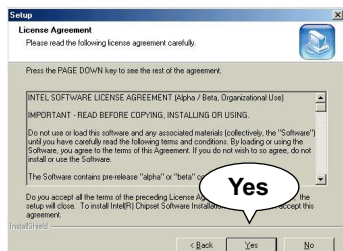

4 After all the setup process is finished, please restart your computer by clicking on “Finish” so as to take the Utility into effect.

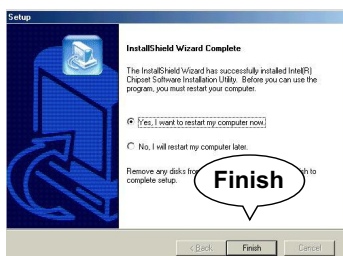

### 3-3 Install “Intel Application Accelerator”

IAA supports all Windows 98/98se/Mellennium/NT4/2000/XP with Pentium III / 4 processor. Installations of this software for these operating systems are similarly programed to an auto-run mode, and it is typically designed to improve performance of the storage sub-system and overall system performance. Below is a model installation on Windows 98. Users of Windows Me/NT4/2000/XP can also follow this example for IAA installation.

**1** Following the procedures of opening the Support CD, click to “Intel Application Accelerator” to proceed.

**2** On the “InstallShield Wizard” screen, Click on “Next” to continue.

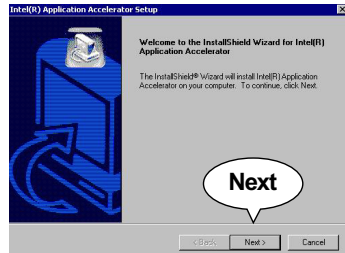

**3** On the “Licence Agreement” screen, click on “Yes” to continue.

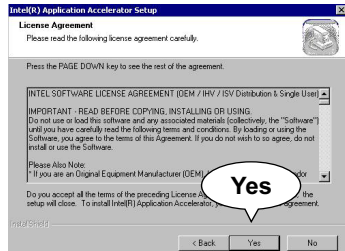

4 On "Choose Destination Location" screen, press "Yes" to continue.

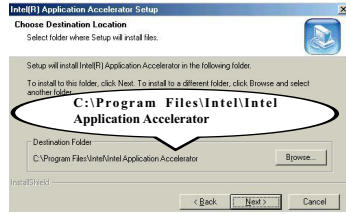

Yes

5 On "InstallShield Wizard Complete" screen, choose "Yes, I want to restart my computer now" and press "finish" to restart. Remember you must restart computer to put setup into effect.



### 3-4 Install “Intel 815 Chipset Graphics Driver”

1 Following the procedures of opening the Support CD, click to “**Graphics Driver**” to proceed.

2 On the “**installshield Wizard**” screen, click on “**Next**” to continue.

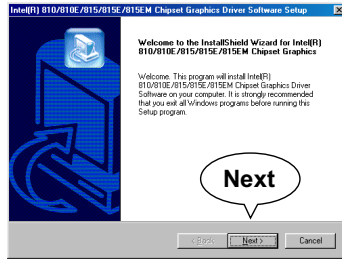

3 Press “**Yes**” to accept Software License Agreement.

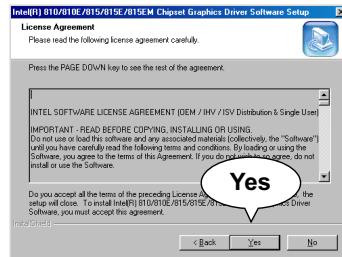

4 On “**installshield Wizard complete**” screen, choose “**Yes, I want to restart my computer now**” and press “**finish**” to restart. Remember you must restart computer to put setup into effect.

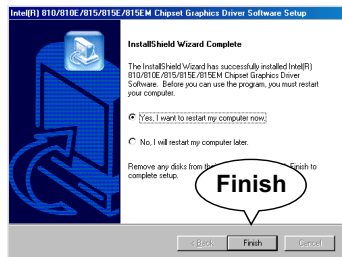

### 3-5 Creative Audio Driver Installation (For 65ME+-T Only)

Please open your Support CD with your CD-ROM drive and select “Creative Audio Driver [Optional] “ to proceed.

#### 3-5.1 To Install Creative Audio Driver

1 As soon as you click to the “Creative Audio Driver [Optional]”, the “Licence Agreement” screen will appear instantly. You must click to “Yes” to continue installation.

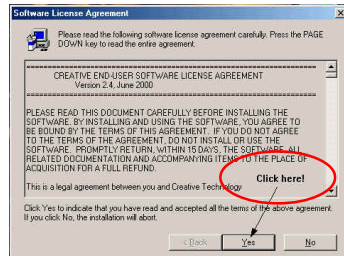

2 Follow the instructions on screens to complete the installation, after which please restart your PC to put the driver into effect.

### 3-5.2 To Enable The Rear Line Out (For 4 Speakers)

After Installation Of Creative Audio Drivers, you should enable the Rear Line Out connector for 4-channel speaker.

- 1 Click to “My computer” icon, and then “Control Panel”, and then “System”, and you will see the “System Properties” screen.
- 2 Click the “Device Manager” button.
- 3 Click the “Creative sound Blaster PCI128” selection, then Click on the “Properties” button.

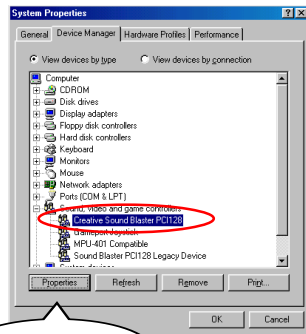

- 4 • When “Creative Sound Blaster PCI128 Properties” Window appears, please Click the 3D Audio button, and then select “Quad Speakers”.
- Click the “OK” button.

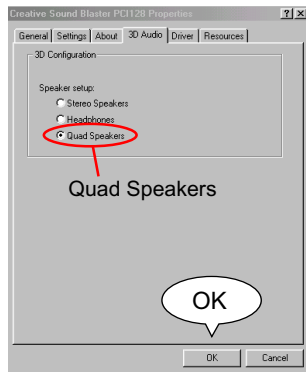

- 5 Your Audio System can now support 4 speakers out. Insert second pair of speakers to the Rear Line out jack to verify this function. (See the following Section 3-4.3 for identifying the Rear Line out jack.)



### 3-5.3 Identifying Connectors On The Built-in Audio

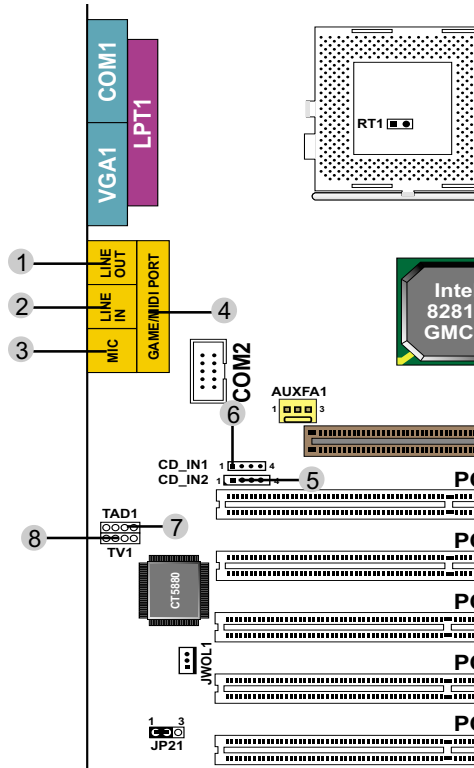

- |   |  |
|---|--|
| <ul style="list-style-type: none"> <li>1 LINE OUT First Speaker Out</li> <li>2 LINE IN Rear LINE OUT JACK (Second pair of speakers output for 65ME+-T only)</li> <li>3 MICROPHONE IN JACK</li> <li>4 GAME/MIDI Connector</li> </ul> | <ul style="list-style-type: none"> <li>5 CD Audio Connector 2</li> <li>6 CD Audio Connector 1</li> <li>7 Telephone Answering Device / Modem Connector (65ME+-T only)</li> <li>8 TV TUNER Connector (65ME+-T only)</li> </ul> |
|---|--|

### 3-6 AC'97 Audio Driver Installation (For 65ME-T Only)

Please open the support CD with your CD-ROM and click to “AC'97 Audio Driver [Optional]”.

1 The next screen will appear for user to select which AC'97 driver you need to install. Supposing that your system is one of Windows 98SE/ME/Win2000, then click on the “Install AC'97 Driver for Win98SE/ME/Win2000”.

2 When the “SoundMAX Install” screen appears, press “Next” to continue.

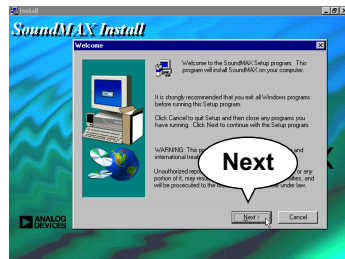

3 After all the setup process is finished, please check the “Yes, I want to restart my computer now.” and click “OK” to restart your system.

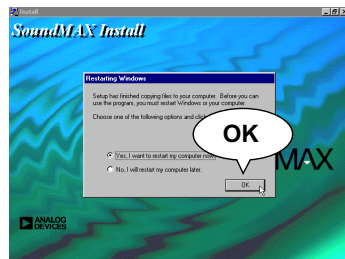

### 3-7 Proceed To Hardware Monitor Utility Installation

1 You have to install Hardware Monitor manually. Please click to the following path to execute Hardware Monitor installation:

D: \ Hardwaremonitor\ ITE \ Install.exe  
(assuming that your CD-ROM Drive is Drive D)

2 In case you are already on the Installation Main Menu of the Support CD, please click to the “Install Hardware Monitor”. Instantly, a message shows up to inform you of the correct path of installing “Hardware Monitor”. Please Exit the message and follow the path as instructed:

For user who wants to install Hardware monitor utility, please install it through this path:  
D:\hardwaremonitor\ITE\install.exe  
(assuming that your CD-ROM Drive is Drive D)

3 Once you enter the path and click to the file “Install.exe”, instantly the “ITE SmartGuardian Install” pops up. Please click to “Install” to continue.



4 In a few second, installation of Hardware Monitor is complete. Please click on the “OK” Dialog Box to finish installation.



- 5 To display the Hardware Monitor Utility, just click on the “ITE SMARTGUARDIAM” icon in your program file, and the following screen of Smartguardian Control Panel will show up, displaying the information about system temperatures, voltages and Fan speed. Clicking to the “Option” menu of the Control Panel, you can also change some Value settings for your system to optimize its performance.

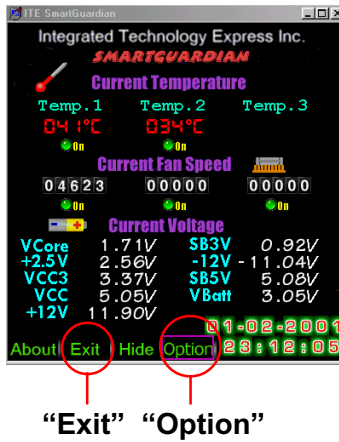



# ***Chapter 4***

## ***BIOS Setup***

---

### **THE BIOS**

- BIOS stands for Basic Input and Output System. It is sometimes called ROM BIOS because it is stored in a Read-Only Memory(ROM) chip on the mainboard. BIOS is the first program to run when you turn on your computer.
- BIOS performs the following functions:
  1. Initializing and testing hardware in your computer (a process called “POST”, for Power On Self Test).
  2. Loading and running your operating system.
  3. Helping your operating system and application programs to manage your PC hardware by means of a set of routines called BIOS Run-Time Service.

---

**This chapter contains the following topics :**

- 4-1 What Is BIOS Setup**
- 4-2 HowTo Run BIOS Setup**
- 4-3 What Is CMOS**
- 4-4 What Is POST**
- 4-5 BIOS Upgrade**
- 4-6 BIOS Setup**

### **4-1 What Is BIOS Setup**

- BIOS setup is an interactive BIOS program that you need to run when:
  1. Changing the hardware of your system. (For example: installing a new Hard Disk etc.)
  2. Modifying the behavior of your computer. (For example: changing the system time or date, or turning special features on or off etc.)
  3. Enhancing your computer's behavior. (For example: speeding up performance by turning on shadowing or cache)

### **4-2 How To Run BIOS Setup**

- To access BIOS setup menu, press < DEL > key after "POST", and before the OS is loaded. The BIOS usually displays the following message:

Press DEL to enter SETUP

### **4-3 What Is CMOS**

- CMOS is the memory maintained by a battery. The BIOS uses CMOS to store the settings you have selected in SETUP. The CMOS also maintains the internal clock. Every time you turn on your computer, the BIOS Looks into CMOS for the settings you have selected and configures your computer accordingly. If the battery is out of power, the CMOS data will be lost and POST will issue a "CMOS invalid" or "CMOS checksum invalid" message. If this happens, you have to replace the battery and do some proper settings in SETUP.

### **4-4 What Is POST**

- POST is an acronym for Power On Self Test. POST will test all things the BIOS does before the operating system is started. Each of POST routines is assigned a POST code, a unique number which is sent to I/O port 080h before the routine is executed.

### **4-5 BIOS Upgrade**

- System BIOS is incorporated into a Flash memory component of the mainboard. Flash BIOS allows user to upgrade BIOS without the need to replace an EPROM component.

- The upgrade utility can be loaded on a floppy diskette and used to provide the capability to save, verify, and update the system BIOS. The upgrade utility can be run from a hard disk drive or a network drive.

#### 4-5.1 Before Upgrading BIOS

- It is highly recommended that you save a copy of the original mainboard BIOS along with a Flash EPROM Programming utility (AWDFLASH.EXE) to a bootable floppy disk in case you need to reinstall the BIOS later.

#### 4-5.2 Upgrade Process

***Note:** Normally, to upgrade BIOS is unnecessary if the system is working fine without any problem. Users should not upgrade the BIOS unless you experience incompatible problems or need to create new features. However, please read all information in this section before upgrading.*

“AWDFLASH.EXE” is a Flash EPROM Programming utility that updates the BIOS by uploading a new BIOS file to the programmable flash ROM on the mainboard. This program only works in **DOS environment only, the utility can not be executed in win95/98, ME, NT or WINDOWS 2000 environment.**

#### Upgrading the system BIOS

- Step 1. Please visit the board maker’s website, download latest BIOS file and award flash utility “AWDFLASH.EXE”. The BIOS file format will be \*.bin, of which “\*” stands for the specific file name.
- Step 2. Create a bootable diskette. Then copy the BIOS file and award flash utility “AWDFLASH.EXE” into the diskette.
- Step 3. Insert the diskette into drive A, reboot your system and boot from the diskette.



- Step 4. Type **awdf flash \*.bin /sn/py/cc** and then press <Enter> to run BIOS upgrade program. (\*.bin depends on your mainboard model and version code. Instead of typing “\*”, you should type specific file name for your specific mainboard).
- Step 5. Please press <F1> or <F10> to exit or reset your system, **Warning !** If the message **“Write Fail”** appears while Award “FLASH MEMORY WRITER” is verifying Flash memory, just repeat the process. Please DO NOT reset or turn off the system. If the award memory flash utility is not able to update the BIOS successfully, your system may not be able to boot up.
- Step 6. You will need a message “CMOS checksum error-Default loaded” during booting the system. Press <Del> to run CMOS setup utility, then reload “LOAD SETUP DEFAULTS” or **“Load Optimized Defaults”** and save this change.

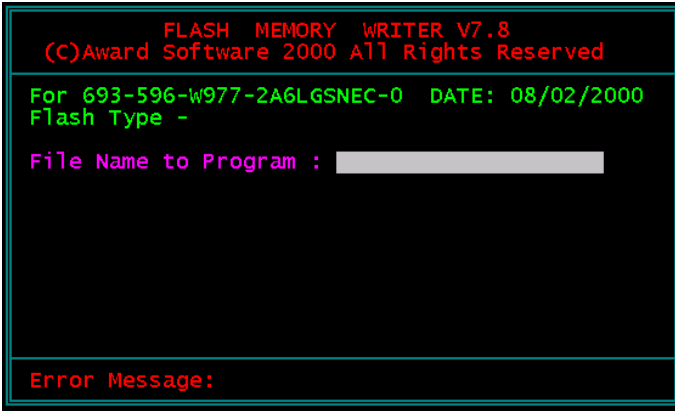

Award Flash Memory Writer Start Screen

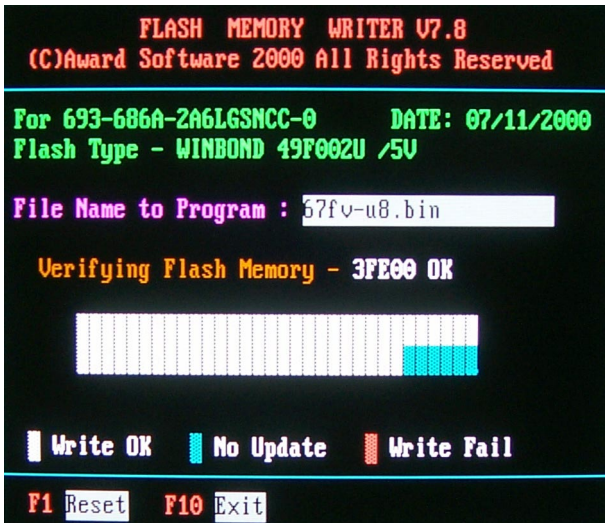

Award Flash Memory Writer Complete Screen

The parameters of AWDFLASH.EXE

/sn: No original BIOS backup

/py: Program flash memory

/cc: Clear CMOS data (and update data automatically) after programming

**NOTE:** Users can type *AWDFLASH /?* to get further details about the parameters. Incorrect usage of the parameter will damage the BIOS information, so we strongly recommend user to leave parameters alone unless you fully understand their function.

## 4-6 BIOS Setup --- CMOS Setup Utility

### 4-6.1 CMOS Setup Utility

- This mainboard comes with the AWARD BIOS from AWARD Software Inc. Enter the CMOS Setup Utility Main Menu by:

1. Turn on or reboot your system. After a series of diagnostic checks, the following message will appear:

**PRESS <DEL> TO ENTER SETUP**

2. Press the <DEL> key and the main program screen will appear as follows.

CMOS Setup Utility - Copyright (C) 1984 - 2001 Award Software

▶ Standard CMOS Features	▶ Frequency/Voltage Control
▶ Advanced BIOS Features	Load Optimized Defaults
▶ Advanced Chipset Features	Set Supervisor Password
▶ Integrated Peripherals	Set User Password
▶ Power Management Setup	Save & Exit Setup
▶ PnP/PCI Configurations	Exit Without Saving
▶ PC Health Status	
Esc : Quit	↑↓→← : Select Item
F10 : Save & Exit Setup	(Shift) F2 : Change Color
Time, Date, Hard Disk Type...	

3. Use the arrow keys on your keyboard to select an option, and press <Enter>. Modify the system parameters to reflect the options installed in your system.
4. You may return to the Main Menu anytime by pressing <ESC>.
5. In the Main Menu, "SAVE AND EXIT SETUP" saves your changes and reboots the system, and "EXIT WITHOUT SAVING" ignores your changes and exits the program.

### 4-6.2 STANDARD CMOS SETUP

- Standard CMOS Setup records some basic system hardware configuration and sets the system clock and error handling. You only need to modify the configuration values of this option if you want to change your system hardware configuration or when the data stored in the CMOS memory gets lost or damaged.

Run the STANDARD CMOS SETUP as follows:

1. Choose “STANDARD CMOS SETUP” from the Main Menu and a screen with a list of options will appear:

CMOS Setup Utility - Copyright (C) 1984 - 2001 Award Software  
Standard CMOS Features

Date (mm:dd:yy)	Wed, May 23 2001	Item Help
Time (hh:mm:ss)	9 : 52 : 15	Menu Level ▶
▶ IDE Primary Master	Press Enter 13022 MB	
▶ IDE Primary Slave	Press Enter None	
▶ IDE Secondary Master	Press Enter None	
▶ IDE Secondary Slave	Press Enter None	
Drive A	1.44M, 3.5 in.	
Drive B	None	
Video	EGA/VGA	
Halt On	All Errors	
Base Memory	640K	
Extended Memory	31744K	
Total Memory	32768K	

↑↓→← : Move Enter:Select +/-/PU/PD:Value F10:Save ESC:Exit F1:General Help  
F5:Previous Values F6:Fail-Safe Defaults F7:Optimized Defaults

2. Use one of the arrow keys to move between options and modify the selected options by using PgUp / PgDn / + / - keys.

**Date (mm:dd:yy)** The BIOS determines the day of the week from the other date information. This field is for information only.

Press the left or right arrow key to move to the desired field (date, month, year). Press the PgUp or PgDn key to increment the setting, or type the desired value into the field.

**Time (hh:mm:ss)** The time format is based on the 24-hour military-time clock. For example, 1 p.m. is 13:00:00. Press the left or right arrow key to move to desired field. Press the PgUp or PgDn key to increment the setting, or type the desired value into the field.

**Primary / Secondary Master / Slave** This field records the specifications for all non-SCSI hard disk drives installed in your system. Refer to the respective documentation on how to install the drives.

CMOS Setup Utility - Copyright (C) 1984-2001 Award Software  
IDE Primary Master

IDE HDD Auto-Detection	Press Enter	Item Help
IDE Primary Master	Auto	Menu Level ▶▶
Access Mode	Auto	
Capacity	13022 MB	
Cylinder	25232	
Head	16	
Precomp	0	
Landing Zone	25231	
Sector	63	

↑↓→←: Move Enter:Select +/-/PU/PD:Value F10:Save ESC:Exit F1:General  
Help F5:Previous Values F6:Fail-Safe Defaults F7:Optimized Defaults

**Drive A / Drive B** Select this field to the type(s) of floppy disk drive(s) installed in your system. The choices are:  
360KB, 5.25in;  
1.2MB, 5.25in;  
720KB, 3.5in;  
1.44MB, 3.5in;  
2.88MB, 3.5in;  
None.

**Video** Select the type of primary video subsystem in your computer. The BIOS usually detects the correct video type automatically. The BIOS supports a secondary video subsystem, but you do not select it in setup.

**Halt On** During the power-on self-test (POST), the computer stops if the BIOS detects a hardware error. You can tell the BIOS to ignore certain errors during POST and continue the boot-up process.

**Base Memory** Typically 640KB. Also called conventional memory. The DOS operating system and conventional applications use this area.

**Extended Memory** Above the 1MB boundary. Early IBM personal computers could not use memory above 1MB, but current PCs and their software can use extended memory.

**Total Memory** This option shows system memory capacity.

3. Press <ESC> to return to the Main Menu when you finish setting up all items.

### 4-6.3 Advanced BIOS Features

- Advanced BIOS Features improves your system performance or sets up system features according to your preference.

Run the Advanced BIOS Features as follows:

1. Choose “Advanced BIOS Features” from the Main Menu and a screen with a list of options will appear:

CMOS Setup Utility - Copyright (C) 1984-2001 Award Software  
Advanced BIOS Features

Virus Warning	Disabled	Item Help
CPU Internal Cache	Enabled	Menu Level ▶
External Cached	Enabled	
CPU L2 Cache ECC Checking	Enabled	
Processor Number Feature	Disabled	
Quick Power On Self Test	Enabled	
First Boot Device	Floppy	
Second Boot Device	HDD-0	
Third Boot Device	CDROM	
Boot Other Device	Enabled	
Swap Floppy Drived	Disabled	
Boot Up Floppy Seek	Disabled	
Boot Up NumLock Status	On	
Gate A20 Option	Fast	
Typematic Rate Setting	Disabled	
× Typematic Rate (Chars/Sec)	6	
× Typematic Delay (Msec)	250	
Security Option	Setup	
OS Select For DRAM > 64MB	Non-OS2	
Report No FDD For WIN95	No	

↑ ↓ → ← : Move Enter:Select +/-/PU/PD:Value F10:Save ESC:Exit F1:General Help  
F5:Previous Values F6:Fail-Safe Defaults F7:Optimized Defaults



2. Use one of the arrow keys to move between options and modify the selected options by using PgUp / PgDn / + / - keys. An explanation of the <F> keys follows:

<F1>: "Help" gives options available for each item.

<F5>: Get the previous values. These values are the values with which the user starts the current session.

<F6>: Load all options with the BIOS default values.

<F7>: Load all options with the Setup default values.

---

**Virus Warning** When enabled, you receive a warning message if a program (specifically, a virus) attempts to write to the boot sector or the partition table of the hard disk drive.

You should then run an antivirus program. Keep in mind that this feature protects only the boot sector, not the entire hard drive.

**NOTE:** *Many disk diagnostic programs that access the boot sector table can trigger the virus warning message. If you plan to run such a program, we recommend that you disable the virus warning.*

**CPU Internal Cache/ External Cache** Cache memory is additional memory that is much faster than conventional DRAM (system memory). CPUs from 486-type up contain internal cache memory, and most, but not all, modern PCs have additional (external) cache memory. When the CPU requests data, the system transfers the requested data from the main DRAM into cache memory, for faster access by the CPU.

**CPU L2 Cache ECC Checking** When you select *Enabled*, it will speed up memory checking when the external cache contains ECC SRAMs.

The choices: Enabled; Disabled.

- Processor Number Feature** Choose Disabled or Enabled. When enabled, the processor serial number will display during the boot up screen.
- Quick Power On Self Test** Select Enabled to reduce the amount of time required to run the power-on self-test (POST). A quick POST skips certain steps. We recommend that you normally enable quick POST.
- First/Second/Third/Other Boot Device** The BIOS attempts to load the operating system from the devices in the sequence selected in these items. The choices: Floppy; LS/ZIP; HDD; SCSI; CDROM; Disabled.
- Swap Floppy Drive** When enabled, floppy drives A and B will be exchanging without any physical connection and modification on the cables.
- Boot Up Floppy Seek** When enabled, the BIOS tests (seeks) floppy drives to determine whether they have 40 or 80 tracks. Only 360-KB floppy drives have 40 tracks; drives with 270KB, 1.2MB, and 1.44MB capacity all have 80 tracks. Because very few modern PCs have 40-track floppy drives, we recommend that you set this field to disabled to save time.
- Boot Up NumLock Status** Toggle between On or Off to control the state of the NumLock key when the system boots. If On, the numeric keypad is in numeric mode. If off, the numeric keypad is in cursor control mode.
- Gate A20 Option** Gate A20 refers to the way the system addresses memory above 1 MB (extended memory). When set to *Fast*, the system chipset controls Gate A20. When set to *Normal*, a pin in the keyboard controller controls Gate A20. Setting Gate A20 to Fast improves system speed, particularly with OS/2 and Windows.

**Typematic Rate Setting** When *Disabled*, the following two items (Typematic Rate and Typematic Delay) are irrelevant. Keystroke repeats at a rate determined by the keyboard controller in your system.

When *Enabled*, you can select a typematic rate and typematic delay.

**Typematic Rate (Chars / Sec)** When the typematic rate setting is enabled, you can select a typematic rate (the rate at which character repeats when you hold down a key) of 6, 8, 10, 12, 15, 20, 24, or 30 characters per second.

**Typematic Delay (Msec)** Choices: 250; 500; 750; 1000. This option sets the time interval for displaying the first and the second characters. If enabled, the time interval is optional.

**Security Option** If you have set a password, select whether the password is required every time the System boots, or only when you enter setup.  
The choices: system; setup.

**OS Select For DRAM > 64MB** Select OS2 only if you are running OS/2 operating system with greater than 64MB of RAM on your system.

**Report No FDD For Win95** Yes: BIOS reports "NO FDD" to Win95.  
No (default): BIOS will not report "NO FDD" to Win95.

3. Press <ESC> to return to the Main Menu when you finish setting up all items.

### 4-6.4 Advanced Chipset Features

- Advanced Chipset Features is used to modify the values of chipset buffers. These buffers control the system options.

Run the Advanced Chipset Features as follows:

1. Choose “Advanced Chipset Features” from the Main Menu and a list of option will appear:

CMOS Setup Utility - Copyright (C) 1984-2001 Award Software  
Advanced Chipset Features

SDRAM CAS Latency Time	3	Item Help
SDRAM Cycle Time Tras/Trc	7/9	Menu Level ▶
SDRAM RAS-To-CAS Delay	3	
SDRAM RAS Precharge Time	3	
System BIOS Cacheable	Disabled	
Video BIOS Cacheable	Disabled	
Memory Hole At 15M-16M	Disabled	
CPU Latency Timer	Disabled	
Delayed Transaction	Enabled	
AGP Graphics Aperture Size	64MB	
System Memory Frequency	Auto	

↑ ↓ → ← : Move Enter: Select +/-/PU/PD: Value F10: Save ESC: Exit F1: General Help  
F5: Previous Values F6: Fail-Safe Defaults F7: Optimized Defaults

2. Use one of the arrow keys to move between options and modify the selected options by using PgUp / PgDn / + / - keys. An explanation of the <F> keys follows:

<F1>: “Help” gives options available for each item.

<F5>: Get the previous values. These values are the values with which the user starts the current session.

<F6>: Load all options with the BIOS default values.

<F7>: Load all options with the Setup default values.

**SDRAM CAS Latency Time** When synchronous DRAM is installed, the number of clock cycles of CAS latency depends on the DRAM timing. Do not reset this field from the default value specified by the system designer.

**SDRAM Cycle Time Tras/Trc** Select the number of SCLKs for an access cycle.  
The choices: 5/7; 7/9

**SDRAM RAS-To-CAS Delay** This field lets you insert a timing delay between the CAS and RAS strobe signals, used when DRAM is written to, read from, or refreshed. Fast gives faster performance and Slow gives more stable performance. This field applies only when synchronous DRAM is installed in the system.  
The Choices: 2; 3

**SDRAM RAS Precharge Time** If an insufficient number of cycles is allowed for the RAS to accumulate its charge before DRAM refresh, the refresh may be incomplete and the DRAM may fail to retain data. Fast gives faster performance; and Slow gives more stable performance. This field applies only when synchronous DRAM is installed in the system.  
The Choices: 2; 3

**System BIOS Cacheable** Selecting Enabled allows caching of the system BIOS ROM at F0000h-FFFFFh, resulting in better system performance.

**Video BIOS Cacheable** Selecting Enabled allows caching of the system BIOS ROM at C0000h to C7FFFh, resulting in video performance. However, if any program writes to this memory area, a system error may result.

**Memory Hole At 15M-16M** You can reserve this area of system memory for ISA adapter ROM. When this area is reserved, it cannot be cached. The user information of peripherals that need to use this area of system memory usually discusses their memory requirements.

**CPU Latency Timer** Use Default setting.

**Delayed Transaction** The chipset has an embedded 32-bit posted write buffer to support delay transactions cycles.  
Select Enabled to support compliance with PCI specification version 2.1.

**AGP Graphics Aperture Size** Choose 32, 64 MB. Memory mapped and graphics data structures can reside in a Graphics Aperture. This area is like a linear buffer. BIOS will automatically report the starting address of this buffer to the O.S.

**System Memory Frequency** Set SDRAM clock speed.  
The choices: Auto; 100MHz; 133MHz.

3. Press <ESC> to return to the Main Menu when you finish setting up all items.

### **4-6.5 Integrated Peripherals**

- Integrated Peripherals option allows you to get some information inside your system when it is working.

Run the Integrated Peripherals as follows:

1. Choose "Integrated Peripherals" from the Main Menu and a list of options will appear:
2. Use one of the arrow keys to move between options and modify the selected options by using PgUp / PgDn / + / - keys. An explanation of the <F> keys follows:

<F1>: "Help" gives options available for each item.

<F5>: Get the previous values. These values are the values with which the user starts the current session.

<F6>: Load all options with the BIOS default values.

<F7>: Load all options with the Setup default values.

CMOS Setup Utility - Copyright (C) 1984-2001 Award Software  
Integrated Peripherals

On-Chip Primary PCI IDE	Enabled	Item Help
On-Chip Secondary PCI IDE	Enabled	Menu Level ▶
IDE Primary Master PIO	Auto	
IDE Primary Slave PIO	Auto	
IDE Secondary Master PIO	Auto	
IDE Secondary Slave PIO	Auto	
IDE Primary Master UDMA	Auto	
IDE Primary Slave UDMA	Auto	
IDE Secondary Master UDMA	Auto	
IDE Secondary Slave UDMA	Auto	
USB Controller	Enabled	
USB Keyboard Support	Disabled	
USB Mouse Support	Disabled	
Init Display First	PCI Slot	
AC97 Audio	Auto	
AC97 Modem	Auto	
Onboard/CNR LAN Selection	Auto	
IDE HDD Block Mode	Enabled	
Power ON Function	BUTTON ONLY	
KB Power ON Password	Enter	
Hot Key Power On	Ctrl - F1	
Onboard FDC Controller	Enabled	
Onboard Serial Port 1	3F8/IRQ4	
Onboard Serial Port 2	2F8/IRQ3	
UART Mode Select	Normal	
UR2 Duplex Mode	Half	
Onboard Parallel Port	378/IRQ7	
Parallel Port Mode	SPP	
ECP Mode Use DMA	3	
PWRON After PWR-Fail	Off	
Game Port Address	201	
Midi Port Address	330	
Midi Port IRQ	10	

↑↓ → ← : Move Enter: Select +/-/PU/PD: Value F10: Save ESC: Exit F1: General Help  
F5: Previous Values F6: Fail-Safe Defaults F7: Optimized Defaults



- On-Chip Primary/Secondary PCI IDE** The chipset contains a PCI IDE interface with support from two IDE channels. Select Enabled to activate the first and/or the second IDE interface. Select Disabled to deactivate an interface if you install a primary and/or second add-on IDE interface. The choices: Enabled; Disabled.
- Primary Master / Slave PIO** Choose Auto or Mode 0~4. The BIOS will detect the HDD mode type automatically when you choose Auto. You need to set to a lower mode than Auto when your hard disk becomes unstable. The choices: Auto; Mode 0; Mode 1; Mode 2; Mode 3; Mode 4.
- Secondary Master / Slave PIO**
- Primary Master / Slave UDMA** Ultra DMA33/66/100 implementation is possible only if your IDE hard drive supports it, if the operating environment includes a DMA drive, and if your system software supports Ultra DMA33/66/100. Select "Auto" to enable BIOS support. The choices: Auto; Disabled.
- Secondary Master / Slave UDMA**
- USB Controller** Select Enabled if your system contains a Universal Serial Bus (USB) controller and you have USB peripherals.
- USB Keyboard Support** Select Enabled if your system contains a Universal Serial Bus (USB) controller and you have a USB keyboard.
- USB Mouse Support** Select Enabled if your system contains a Universal Serial Bus (USB) controller and you have a USB mouse.
- Init Display First** Initialize the AGP video display before initializing any other display device on the system. Thus the AGP display becomes the primary display.
- AC97 Audio/Modem** This option allows you to decide to enable/disable the 815 chipset to support AC97 Audio/Modem. The choices: Auto; Disabled

**Onboard/CNR LAN** Use the default setting.  
**Selection** The choices: Auto; Onboard

**IDE HDD Block Mode** Block mode is also called block transfer, multiple commands, or multiple sector read/write. If your IDE hard drive supports block mode (most new drives do), select Enabled for automatic detection of the optimal number of block read/write per sector the drive can support.  
The choices: Enabled; Disabled.

**Power ON Function** This option allows you to select <KB Power ON Password> , <Hot-Key Power ON> or others.  
The choices: Any Key, Button only, Keyboard 98, Password, Hot-Key, Mouse Move, Mouse Click.

**KB Power ON Password** When user sets a password for keyboard, the password user set that return the system to Full On state.

**Hot-Key Power ON** Boot up the system via predetermined keyboard hot key.  
The choices: <Ctrl>+<F1>...<F12>

**Onboard FDC Controller** Select Enabled if your system has a floppy drive controller (FDC) installing in the system board and you want to use it. If you install add-in FDC or the system has no floppy drive, select Disabled in this field.  
The choices: Enabled; Disabled.

**Onboard Serial Port 1 / Port 2** Select a logical COM port name and matching address for the first and second serial ports. Select an address and corresponding interrupt for the first and second serial ports.

**UART Mode Select** The second serial port on your system may offer a variety of infrared port modes. Click here for a description of various modes. (Click your browser's Back button, or your right mouse button, to return to this page.)  
The choices: Standard; HPSIR; ASKIR

**UR2 Duplex Mode** This item allows you to select the IR half / full duplex function.  
The choices: Half; Full.

**Onboard Parallel Port** This item allows you to determine onboard parallel port controller I/O address setting.  
The choices: 378H/IRQ7; 278H/IRQ5; 3BC/IRQ7; Disabled.

**Parallel Port Mode** Select an operating mode for the on-board parallel (printer) port. Select Normal, Compatible, or SPP unless you are certain your hardware and software both support one of the other available modes.

**ECP Mode Use DMA** Select a DMA channel for the port.

**PWRON After PWR-Fail** Off: Disable Power Lost Resume function.  
On: Enable Power Lost Resume function.  
Former Sts: Use Former status.  
The choices: Off; On; Former Sts.

**Game Port Address** This item allows you to select the Game Port Address.  
The choices: Disable; 201; 209

**MIDI Port Address** Select a DMA channel for the parallel port for use during ECP mode.  
The choices: Disabled; 330; 300

**MIDI Port IRQ** This item allows you to select the MIDI Port IRQ.  
The choices: 5; 10

3. Press <ESC> to return to the Main Menu when you finish setting up all items.

### 4-6.6 Power Management Setup

- Power Management Setup allows you to set the system’s power saving functions.

Run the Power Management Setup as follows:

1. Choose “Power Management Setup” from the Main Menu and a list of options will appear:

CMOS Setup Utility - Copyright (C) 1984 - 2001 Award Software  
Power Management Setup

ACPI Function	Enabled	Item Help
ACPI Suspend Type	S1(POS)	Menu Level ▶
Power Management	User Define	
Video Off Method	V/H SYNC+Blank	
Video Off In Suspend	Yes	
Suspend Type	Stop Grant	
MODEM Use IRQ	3	
Suspend Mode	Disabled	
HDD Power Down	Disabled	
Soft-Off by PWR-BTTN	Instant-Off	
Wake-up by PCI card	Disabled	
Power On by Ring	Disabled	
USB KB Wake-Up From S3	Disabled	
Resume by Alarm	Disabled	
× Date (of Month) Alarm	0	
× Time (hh:mm:ss)	0 0 0	
** Reload Global Timer Events **		
Primary IDE 0	Disabled	
Primary IDE 1	Disabled	
Secondary IDE 0	Disabled	
Secondary IDE 1	Disabled	
FDD, COM, LPT Port	Disabled	
PCI PIRQ[A-D] #	Disabled	

↑ ↓ → ←: Move Enter: Select +/-/PU/PD: Value F10: Save ESC: Exit F1: General Help  
F5: Previous Values F6: Fail-Safe Defaults F7: Optimized Defaults

2. Use one of the arrow keys to move between options and modify the selected options by using PgUp / PgDn / + / - keys. An explanation of the <F> keys follows:

<F1>: "Help" gives options available for each item.

<F5>: Get the previous values. These values are the values with which the user starts the current session.

<F6>: Load all options with the BIOS default values.

<F7>: Load all options with the Setup default values.

---

**ACPI Function** Select Enabled only if your computer's operating system supports the Advanced Configuration and Power Interface (ACPI) specification. Currently, Windows NT 5.0 supports ACPI.

**ACPI Suspend Type** This item allows you to select the ACPI suspend type. You can select S1(POS) for power on suspend under Windows 98 ACPI mode.  
The choices: S1(POS).

**Power Management** This option allows you to select the type (or degree) of power saving for Doze, Standby, and Suspend modes.  
This table describes each power management mode:

Max Saving	Maximum power savings. Only Available for SL CPUs. Inactivity period is 1 minute in each mode.
User Define	Set each mode individually. Select time-out period in the section for each mode stated below.
Min Saving	Minimum power savings. Inactivity period is 1 hour in each mode (except the hard drive).

**Video Off Method** This determines the manner by which the monitor is blanked.

V/H SYNC + Blank	This selection will cause the system to turn off the vertical and horizontal synchronization ports and write blanks to the video buffer.
Blank Screen	This option only writes blanks to the video buffer.
DPMS Supports	Select this option if you monitor supports the Display Power Management Signaling (DPMS) standard of the Video Electronics Standards to select video power management values.

**Video Off in Suspend** This determines the manner in which the monitor is blanked.

The choices: Yes; No.

**Suspend Type** Select the Suspend Type.

The choices: PWRON Suspend; Stop Grant.

**MODEM Use IRQ** Name the interrupt request (IRQ) line assigned to the modem (if any) on your system. Activity of the selected IRQ always awakens the system.

The choices: 3; 4; 5; 7; 9; 10; 11; NA.

**Suspend Mode** After the selected period of system inactivity, the chipset enters a hardware suspend mode, stopping the CPU clock and possibly causing other system devices to enter power management modes.

**HDD Power Down** When enabled and after the set time of system inactivity, the hard disk drive will be powered down while all other devices remain active.

**Soft-Off by PWRBTN** When Enabled, turning the system off by pressing the on/off button places the system in a very low-power-usage state.

**Wake-up by PCI card** This function allows you to enable the system by wake-up by PCI card.  
The choices: Delay 4 Sec; Instant-Off.

**Power On by Ring** An input signal on the serial Ring Indicator (RI) line (in other words, an incoming call on the modem) awakens the system from a soft off state.  
The choice: Enabled; Disabled.

**USB KB Wake-Up From S3** This item will enable you to wake-up the system by USB keyboard when you shut down the computer in S3 Mode.  
The choices: Enabled; Disabled.

**Resume by Alarm** When Enabled, you can set the data and time at which the RTC (Real Time Clock) alarm awakens the system from suspend mode.

**Date (of Month) Alarm** Set a certain date when RTC Alarm Resume option is Enabled to awaken the system. This option is concurrent with Resume Time option.

**Time (hh:mm:ss)** Set a certain time when RTC Alarm Resume option is Enabled to awaken the system. This option is concurrent with Date option.

**Reload Global Timer Events** Reload Global Timer Events are I/O events whose occurrence can prevent the system from entering a power saving mode or can awaken the system from such a mode. In effect, the system remains alert for anything which occurs to a device which is configured as Enabled, even when the system is in a power down mode.

Primary IDE 0

Primary IDE 1

Secondary IDE 0

Secondary IDE 1

FDD, COM, LPT Port

PCI PIPQ[A-D]

3. Press <ESC> to return to the Main Menu when you finish setting up all items.



### 4-6.7 PNP / PCI Configuration

- PNP / PCI Configuration allows you to modify the system's power saving functions.

Run the PNP / PCI Configuration as follows:

1. Choose "PNP / PCI Configuration" from the Main Menu and a screen with a list of options will appear:

CMOS Setup Utility - Copyright (C) 1984 - 2001 Award Software  
PnP/PCI Configurations

Reset Configuration Data	Disabled	<b>Item Help</b>
Resources Controlled By × IRQ Resources	Auto(ESCD) Press Enter	Menu Level ▶
PCI/VGA Palette Snoop	Disabled	
PCI SLOT1/5 IRQ Assigned	Auto	
PCI SLOT2 IRQ Assigned	Auto	
PCI SLOT3 IRQ Assigned	Auto	
PCI SLOT4 IRQ Assigned	Auto	

↑ ↓ → ←: Move Enter:Select +/-/PU/PD:Value F10:Save ESC:Exit F1:General Help  
F5:Previous Values F6:Fail-Safe Defaults F7:Optimized Defaults

2. Use one of the arrow keys to move between options and modify the selected options by using PgUp / PgDn / + / - keys. An explanation of the <F> keys follows:

<F1>: "Help" gives options available for each item.

<F5>: Get the previous values. These values are the values with which the user starts the current session.

<F6>: Load all options with the BIOS default values.

<F7>: Load all options with the Setup default values.

**Reset Configuration Data** Normally, you leave this Disabled. Select Enabled to reset Extended System Configuration Data (ESCD), when you exit Setup if you have installed a new add-on and the system reconfiguration has caused such a serious conflict that the operating system cannot boot.

**Resource Controlled By** The Plug and Play AwardBIOS can automatically configure all the boot and Plug and Play-compatible devices. If you select *Auto*, all the interrupt request (IRQ) and DMA assignment fields disappear, as the BIOS automatically assigns them.

**IRQ RESOURCES** Press Enter. Please refer to the list below:

CMOS Setup Utility - Copyright (C) 1984 - 2001 Award Software  
IRQ Resources

			Item Help
IRQ-3	assigned to	PCI Device	Menu Level ▶
IRQ-4	assigned to	PCI Device	
IRQ-5	assigned to	PCI Device	
IRQ-7	assigned to	PCI Device	
IRQ-9	assigned to	PCI Device	
IRQ-10	assigned to	PCI Device	
IRQ-11	assigned to	PCI Device	
IRQ-12	assigned to	PCI Device	
IRQ-14	assigned to	PCI Device	
IRQ-15	assigned to	PCI Device	

↑↓→←:Move Enter:Select +/-/PU/PD:Value F10:Save ESC:Exit F1:General Help  
F5:Previous Values F6:Fail-Safe Defaults F7:Optimized Defaults

**PCI/VGA Palette Snoop** This option allows the BIOS to preview VGA status, and to modify the information delivered from the feature Connector of the VGA card to MPEG card. This option can solve the display inversion to black after you have used MPEG card.

**PCI SLOT1/5, 2, 3, 4** These options allow you to assign an IRQ for each **IRQ Assigned** PCI SLOT and this is a useful function when you want to clear the IRQ conflict for a specific device. The options are available : Auto; 3; 4; 7; 9; 10; 11.

3. Press <ESC> to return to the Main Menu when you finish setting up all items.

### 4-6.8 PC Health Status

- This section helps you to get more information about your system including CPU temperature, FAN speed and voltage. It is recommended that you contact your mainboard supplier to get proper values about the setting of the CPU temperature.

Run the “PC Health Status” as follows:

1. Choose “PC Health Status” from the Main Menu and a screen with a list of options will appear:

CMOS Setup Utility - Copyright (C) 1984 - 2001 Award Software  
SmartDoc Anti-Burn Shield

Shutdown Temperature	60 °C/140 °F	Item Help
Voltage 0	0	1.87 V
Voltage 1	1	2.00 V
Voltage 2	2	3.37 V
Voltage 3	3	5.02 V
Voltage 4	4	12.28 V
Voltage 5	5	(-)12.52 V
Voltage 6	6	(-)5.10 V
Voltage 7	7	5.08 V
Voltage Battery		3.08 V
Temperature 1		41 °C
Temperature 2		(-)55 °C
Temperature 3		(-)55 °C
Fan 1 Speed		5625 RPM
Fan 2 Speed		0 RPM
Fan 3 Speed		0 RPM
		Menu Level ▶

↑ ↓ → ← : Move Enter:Select +/-/PU/PD:Value F10:Save ESC:Exit F1:General Help  
F5:Previous Values F6:Fail-Safe Defaults F7:Optimized Defaults

2. Use one of the arrow keys to move between options and modify the selected options by using PgUp / PgDn / + / - keys.

<F1>: “Help” gives options available for each item.

<F5>: Get the previous values. These values are the values with which the user starts the current session.

<F6>: Load all options with the BIOS default values.

<F7>: Load all options with the Setup default values.

**Shutdown Temperature** This feature prevents your CPU from damage by over heat. If the CPU's temperature is higher than "CPU warning temperature" that you select in this field, the BIOS will shut down your system within 3 seconds.

**Voltage** Shows power supply actual voltage value.

**Temperature 1/2/3** Shows current temperature.

**FAN 1/2/3 Speed** These fields display the current speed of up to three CPU fans, if your computer contains a monitoring system.

3. Press <ESC> to return to the Main Menu when you finish setting up all items.

### 4-6.9 Frequency/Voltage Control

Run the "Frequency/Voltage Control" as follows:

1. Choose "Frequency/Voltage Control" from the Main Menu and a screen with a list of options will appear:

CMOS Setup Utility - Copyright (C) 1984-2001 Award Software  
Frequency Control

Redstorm Overclocking Tech	Press Enter	Item Help
Auto Detect DIMM/PCI Clk	Enabled	Menu Level ▶
× Spread Spectrum Modulated	Disabl	
× Linear Spread Model	3	
Linear Spread Range	0	
CPU Skew Adjust	Disabled	
PCI Skew Adjust	Disabled	
SDRAM Skew Adjust	Disabled	
AGP Skew Adjust	Disabled	
CPU Host/PCI Clock	66	
CPU Clock Ratio	x3	

↑↓←→: Move Enter:Select +/-/PU/PD:Value F10:Save ESC:Exit F1:General Help  
F5:Previous Values F6:Fail-Safe Defaults F7:Optimized Defaults

2. Use one of the arrow keys to move between options and modify the selected options by using PgUp / PgDn / + / - keys.

<F1>: "Help" gives options available for each item.

<F5>: Get the previous values. These values are the values with which the user starts the current session.

<F6>: Load all options with the BIOS default values.

<F7>: Load all options with the Setup default values.

**Redstorm Overclocking Tech** Please press <Enter> to start *RED STORM OVERCLOCKING TECH*, this option helps user an easy way to overclocking, it will increase CPU external clock automatically, when CPU external clock increasing to unacceptable value, BIOS will restart your system, then running at acceptable CPU external clock.

**Auto Detect DIMM/PCI CLK** To reduce the occurrence of electromagnetic interference (EMI), the BIOS detects the presence or absence of components in DIMM and PCI slots and turns off system clock generator pulses to empty slots.

**Spread Spectrum Modulated** When the system clock generator pulses, the extreme values of the pulse generate excess EMI. Enabling pulse spectrum spread modulation changes the extreme values from spikes to flat curves, thus reducing EMI. This benefit may in some cases be outweighed by problems with timing-critical devices, such as a clock-sensitive SCSI device.

**Linear Spread Model** This item allows you to enable/disable the linear spread model.  
The choices: Enabled; Disabled.

**Linear Spread Range** This item allows you to enable/disable the linear spread range.  
The choices: Enabled; Disabled.

**CPU Skew Adjust** This item allows you to reduce CPU transfer rate.  
Users should leave this item at default value.  
The choices: Disabled; 150ps; 300ps; 450ps.

**PCI Skew Adjust** This item allows you to reduce PCI transfer rate.  
Users should leave this item at default value.  
The choices: Disabled; 150ps; 300ps; 450ps.

**SDRAM Skew** This item allows you to reduce SDRAM transfer rate.  
**Adjust** Users should leave this item at default value.  
The choices: Disabled; 150ps; 300ps; 450ps.

**AGP Skew** This item allows you to reduce AGP transfer rate.  
**Adjust** Users should leave this item at default value.  
The choices: Disabled; 150ps; 300ps; 450ps.

**CPU Host/PCI** Select Default or select a timing combination for the  
**Clock** CPU and the PCI bus. When set to Default, the BIOS  
uses the actual CPU and PCI bus clock values.

**CPU Clock** This item allows you to select the CPU ratio, if CPU  
**Ratio** clock Ratio is locked, the function will have no effect.

3. Press <ESC> to return to the Main Menu when you finish setting up all items.



### 4-6.10 Load Optimized Defaults

- When you press <Enter> on this item, you will get a confirmation dialog box with a message similar to:

`“ Load Optimized Defaults (Y/N) ? N ”`

“Y” is for “Yes”, and “N” is for “No”.

Pressing “Y” loads the BIOS default values that are factor settings for optimal performance of system operations.

### 4-6.11 Set Super Visor / User Password

- These two options allow you to set your system passwords. Normally, the supervisor has a higher priority to change the CMOS setup option than the users. The way to set up the passwords for both Supervisor and Users are as follows:

1. Choose “Change Password” in the Main Menu and press <Enter>. Then following message appears:

`“Enter Password : ”`

2. The first time you run this option, enter your password up to 8 characters and press <Enter>. (The screen does not display the entered characters.)
3. After you enter the password, the following message appears prompting you to confirm the password:

`“Confirm Password : ”`

4. Enter the same password “exactly” the same as you have just typed to confirm the password and press <Enter>.
5. Move the cursor to Save & Exit Setup to save the password.
6. If you need to delete the password entered before, choose the Supervisor Password and press <Enter>. It will delete the password that you have entered before.

7. Move the cursor to Save & Exit Setup to save the option you have just configured; otherwise the old password will still be there the next time you turn your system on.
8. Press <Enter> to exit to the Main Menu.

**NOTE:** *If you forget or lose the password, the only way to access the system is to clear the CMOS RAM. All setup informations will be lost and you need to run the BIOS setup program again.*

#### 4-6.12 Save & Exit Setup

- SAVE & EXIT SETUP allows you to save all modifications you have specified into the CMOS memory. Highlight this option on the Main Menu and the following message appears:

`"SAVE to CMOS and EXIT (Y/N) ? Y "`

"Y" is for "Yes", and "N" is for "No".

Press <Enter> key to save the configuration changes.

#### 4-6.13 Exit Without Saving

- EXIT WITHOUT SAVING option allows you to exit the Setup Utility without saving the modifications that you have specified. Highlight this option on the Main Menu and the following message appears:

`"Quit Without Saving (Y/N) ? N "`

"Y" is for "Yes", and "N" is for "No".

You may change the prompt to "Y" and press <Enter> key to leave this option .



# *Appendix*

---

**Appendix-1 Identifying BIOS Version/BIOS  
Part Number**

**Appendix-2 Identifying Mainboard Model  
Number**

**Appendix-3 Technical Terms**

---

## Appendix-1 Identifying BIOS Version & BIOS Part Number

- See Picture-2 below for BIOS version and BIOS part number identification.

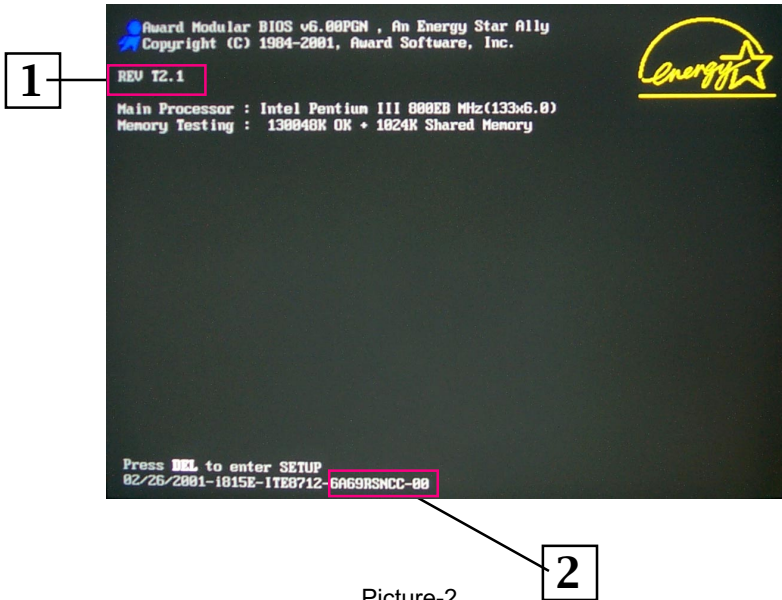

Picture-2

1. BIOS VERSION  
example: REV T2.1
2. BIOS ID STRING  
example: 6A69RSNCC

## Appendix-2 Identifying Mainboard model Number

- Usually the mainboard model number is labeled on the side of ISA side of slot or PCI slot. Please see the picture below as an illustration:

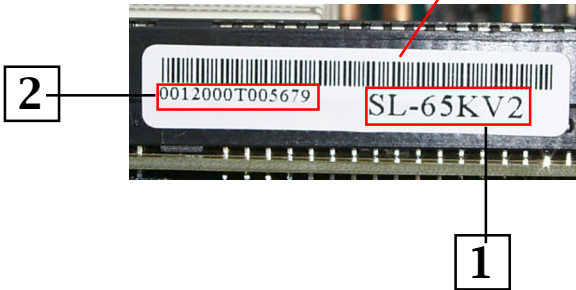
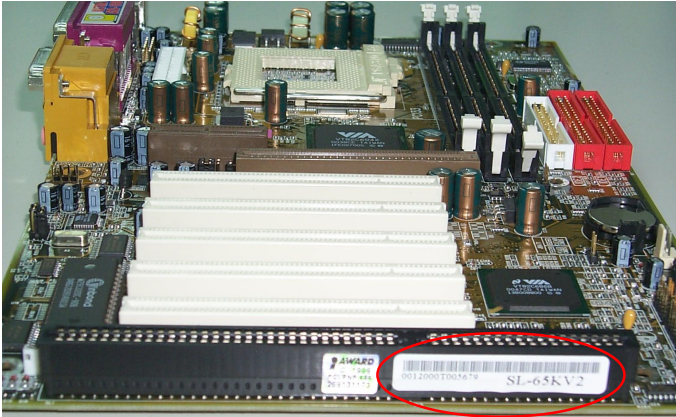

1. MAINBOARD MODEL NUMBER  
example: SL-65KV2
2. MAINBOARD SERIAL NUMBER  
example: 0012000T005679

## Appendix-3 Technical Terms

### **AC'97**

AC'97 is a device designed to include a digital processor for modem and an audio CODEC for analog I/O. These two parts are linked together by AC'97 link bus. Putting the digital processor into the main system chipset will reduce the cost of sound/modem onboard solution.

### **ACPI (Advanced Configuration & Power Interface)**

ACPI is developed together by Intel, Microsoft and Toshiba. This interface provides a channel of management of the PC system and its hardware such as CPU and BIOS, pushing the PC power management to a more advanced and user-friendly level.

### **AGP (Accelerated Graphic Port)**

AGP is a bus interface targeted for high-performance 3D graphics. AGP takes advantage of both rising and falling edge of the 66MHz clock. For 2X AGP, the data transfer rate is  $66\text{MHz} \times 4\text{byte} \times 2 = 528\text{MB/s}$ . AGP 4X mode is  $66\text{MHz} \times 4\text{byte} \times 4 = 1056\text{MB/s}$ .

### **AMR (Audio/Modem Riser)**

AMR is an interface to connect the CODEC circuit of AC'97 sound/modem solution to the mainboard through an AMR card and an AMR connector.

### **APM (Advanced Power Management)**

APM is developed by Intel and Microsoft, intending for PC power management through the system BIOS. Through APM, the PC power consumption can be reduced to 5W or lower.

### **ATA (AT Attachment), ATA/66, ATA/100**

ATA is the specification of disk drive interface, that integrates the controller on the disk drive itself with the IDE technology.

ATA/66 uses both rising edge and falling edge to provide a data transfer rate  $16.6\text{MB/s} \times 4 = 66\text{MB/s}$ . To use ATA/66, you need special ATA/66 IDE cable.

ATA/100 also uses both rising edge and falling edge as ATA/66, but clock cycle time is reduced to 40ns. The data transfer rate is  $(1/40\text{ns}) \times 2 \text{ bytes} \times 2 = 100\text{MB/s}$ . To use ATA/100, you need special 80-wire IDE cable, the same as ATA/66.

**ATAPI (AT Attachment Packet Interface)**

This is the extension of the EIDE (extended IDE) that enables the interface to support CD-ROM players and tape drives.

**BIOS (Basic Input/Output System)**

BIOS is a set of assembly routine/program that resides in EPROM or Flash ROM. BIOS controls Input/output devices and other hardware devices of the mainboard. Generally, operation system and drivers will access BIOS before accessing hardware devices so as to enhance the portability of the hardware devices.

**Bus Master IDE (DMA mode)**

An IDE interface is an interface for mass storage devices, in which the controller is integrated into the disk or CD-ROM itself. To reduce the workload of the CPU, the bus master IDE device transfers data from/to memory without interrupting CPU, and releases CPU to operate concurrently while data is transferring between memory and IDE device. You need the bus master IDE driver and the bus master IDE HDD to support bus master IDE mode.

**CAS (Column Address Strobe)**

CAS is a technology of DRAM writes and reads. The number of clock cycles of the CAS signals is depending on the DRAM timing.

**CNR (Communication and Networking Riser)**

CNR interface provides a cost reducing method of implementing LAN, home networking, DSL, USB, wireless, audio and modem subsystems through a CNR card and a CNR connector.

**CODEC (Coder and Decoder)**

Normally, CODEC means a circuit that can do digital to analog conversion and vice versa. It is part of AC'97 sound/modem solution.

**DDR (Double Data Rated) SDRAM**

DDR SDRAM essentially doubles the memory speed of SDRAMs without increasing the clock frequency.



**DIMM (Dual In Line Memory Module)**

DIMM socket is built with a 168-pin assignment and supports 64-bit data. DIMM can be single or double sided. The golden finger signals on each side of the module are different, and that is why it is called Dual In Line. Almost all DIMMs are made with SDRAM now, which operate at 3.3V. Some old DIMMs are made by FPM/EDO and only operate at 5V.

**DMA (Direct Memory Access)**

Channel for communications between memory and surrounding devices.

**ECC (Error Checking and Correction)**

The ECC algorithm has the ability to detect double-bit error and automatically correct single-bit error while parity mode can only detect single-bit error.

**ECP (Enhanced Communication Port)**

ECP is a technology designed to improved I/O for parallel ports.

**EPP (Enhanced Parallel Port)**

EPP is a standard that supports data transfer rates of up to 500 kps for parallel printers

**EDO (Extended Data Output) Memory**

Unlike traditional FPM (Fast Page Mode) memory that tri-states the memory output data to start the pre-charge activity, EDO DRAM holds the memory data valid until the next memory access cycle, which is similar to pipeline effect in reducing one clock state.

**EEPROM (Electronic Erasable Programmable ROM)**

Both EEPROM and Flash ROM can be re-programmed by electronic signals, but the interface technology is different. Size of EEPROM is much smaller than flash ROM. BIOS is now generally stored in EEPROM or Flash ROM.

**EPROM (Erasable Programmable ROM)**

Traditional mainboard stores BIOS codes in EPROM which can only be erased by ultra-violet (UV) light. If BIOS has to be updated, you need to remove EPROM from mainboard, clear data by UV light, re-program, and then insert it back to socket.

### **FC-PGA (Flip Chip-Pin Grid Array)**

FC means Flip Chip, while FC-PGA is a new package of Intel for Pentium III CPU. It is compatible with SKT370 socket, but requires mainboard to add some signals on socket 370.

### **Flash ROM**

Flash ROM can be re-programmed by electronic signals. It is easier for BIOS to upgrade by a flash utility, but it is also easier to be infected by virus. Because of increase of new functions, BIOS size is increased from 64KB to 256KB (2M bit) or more.

### **FSB (Front Side Bus)**

FSB is the data channel connecting the Processor to chipset, RAM, mainboard buses, AGP socket etc. Its speed is in terms of MHz and is talked to as FSB clock:

FSB Clock means CPU external bus clock.

CPU internal clock = CPU FSB Clock x CPU Clock Ratio

### **IEEE 1394**

IEEE 1394 is a low-cost digital transfer interface with transfer rate at 100, 200 or 400 Mbps. It provides solutions of connecting digital television devices and Serial Bus Management. There are two type of IEEE 1394 data transfer: asynchronous and isochronous. Isochronous data channels provide guaranteed data transport at a pre-determined rate. This is especially important for time-critical multimedia data where just-in-time delivery eliminates the need for costly buffering.

### **Parity Bit**

The parity bit mode of error detection uses 1 parity bit for each byte. Normally it is even parity mode, that is, each time the memory data is updated, parity bit will be adjusted to have even count “1” for each byte. Next time when memory is read with odd number of “1”, the parity error is occurred and this is called single bit error detection.

### **PC-100 DIMM**

SDRAM DIMM that supports 100MHz CPU FSB bus clock.

### **PC-133 DIMM**

SDRAM DIMM that supports 133MHz CPU FSB bus clock.

**PC-1600 or PC-2100 DDR SDRAM**

PC-1600 DDR SDRAM with a 64-bit data bus doubles the data transfer rate of PC100 SDRAM and hence provides data transfer bandwidth up to  $100 \times 64 / 8 \times 2 = 1600 \text{MB/s}$ . PC2100 DDR SDRAM doubles the data transfer rate of PC-133 and hence provides data transfer bandwidth up to  $133 \times 64 / 8 \times 2 = 2100 \text{MB/s}$ .

**PCI (Peripheral Component Interface) Bus**

A high speed data channel for the internal connection of peripheral devices and the computer system through a PCI expansion card.

**PnP (Plug and Play)**

The PnP specification suggests a standard register interface for both BIOS and operating system (such as Windows 95). These registers are used by BIOS and operating system to configure system resource and prevent any conflicts. PnP BIOS or operating system will automatically allocate the IRQ/DMA/Memory. Currently, almost all the PCI cards and most ISA cards are already PnP compliant.

**POST (Power-On Self Test)**

The BIOS self-test procedure after power-on. It is generally the first or the second program shown on your monitor screen during system boot.

**RAS (Row Address Strobe)**

RAS is a technology that DRAM writes and reads to the Row addresses, while a CAS (Column Address Strobe) signal is used to validate the column address. The signals are generally sent CAS before RAS.

(in Network field, RAS stands for Remote Access Services).

**RDRAM (Rambus DRAM)**

Rambus DRAM is a memory technology that uses large burst mode data transfer of up to 1.6GHz. It is import to know that RDRAM technology helps set up a system level improvement, not just a component upgrade.

**RIMM (Rambus Inline Memory Module)**

RIMM is built with a 184-pin architecture module that supports RDRAM memory technology. A RIMM memory module may contain up to maximum of 16 RDRAM devices.

**SDRAM (Synchronous DRAM)**

SDRAM is one of the Dynamic Random Access Memory (DRAM) technologies that allow DRAM to use the same clock as the CPU host clock (EDO and FPM are asynchronous and do not have clock signal). SDRAM comes in 64-bit 168-pin DIMM and operates at 3.3V.

**SIMM (Single In Line Memory Module)**

SIMM socket is only 72-pin, and is only single side. The golden finger signals on each side of PCB are identical. That is why it is called Single In Line. SIMM is made of FPM or EDO DRAM and supports 32-bit data. SIMM is phased out in current mainboard design.

**SPD (Serial Presence Detect)**

SPD is a small ROM or EEPROM device resided on the DIMM or RIMM. Memory module information such as DRAM timing and chip parameters can be stored into SPD so that BIOS can access it and use it to decide best timing for this DIMM or RIMM.

**UART (Universal Asynchronous Receiver/transmitter)**

UART is built in a chip that controls the data sent to and received from a serial port. A 16550 UART is now standard in most PCs, and supports modem speed up to 57,600 bps and beyond and direct connect speed of 115,200 bps. Many UARTs have built-in errors in the internal code and just do not work correctly with many external modems. UART is also found as the serial interface on internal modem.

**Ultra DMA**

Ultra DMA (or, more accurately, Ultra DMA/33) is a protocol for transferring data at 33.3MB/s between a hard disk drive through the computer's data path (or bus) to the computer's random access memory (RAM). The transfer data is twice as fast as the previous Direct Access Memory (DMA) interface. The latest Ultra DMA has advanced to Ultra DMA/66 and Ultra DMA/100.

16.6MB/s x2 = 33MB/s

16.6MB/s x4 = 66MB/s

16.6MB/s x6 = 100MB/s

### **USB (Universal Serial Bus)**

USB is a 4-pin serial peripheral bus that is capable of cascading low/medium speed peripherals (less than 10Mbit/s) such as keyboard, mouse, joystick, scanner, printer and modem.

### **VCM (Virtual Channel Memory)**

NEC's Virtual Channel Memory (VCM) is a new DRAM core architecture that dramatically improves the memory system's ability to service multimedia requirements. VCM increases memory bus efficiency and performance of any DRAM technology by providing a set of fast static registers between the memory core and I/O pins. Using VCM technology results in reduced data access latency and reduced power consumption.

### **VRM (Voltage regulator Module)**

This is a small module installed on a mainboard to regulate the voltage fed to the processor on board. Voltage regulator can be built on board in various way. VRM is a socketed type of regulator module which is easier to change when needed.

### **Zero Wait State**

When memory is operating at its fastest speed in its course of fetching and yielding data, it allows no "no-op" cycle and is called in a zero wait state. On the other hand, a memory is in a wait state, after it gets a command to fetch data, it waits for one, two or more cycles to assure that the expected data is in the buffer.

### **ZIP file**

Zip file is a compressed file with a reduced file size.

### **Zoom**

To zoom is to make a window or screen larger or smaller in a Graphical User Interface of a computer system. Usually, to "zoom in" means to enlarge, and to "zoom out" means to reduce size.

**MEMO**

---