Federal Communications Commission Statement

This device complies with FCC Rules Part 155. Operation is subject to the following two conditions:

- ♦ This device may not cause harmful interference
- ♦ This device must accept any interference received, including interference that may cause undesired operation.

This equipment has been tested and found to comply with the limits for a Class B digital device, pursuant to Part 15 of the FCC Rules. These limits are designed to provide reasonable protection against harmful interference in a residential installation. This equipment generates, uses and can radiate radio frequency energy. If this equipment is not installed and used in accordance with the manufacturer's instructions, it may cause harmful interference to radio communications. However, there is no guarantee that interference will not occur in a particular installation. If this equipment does cause harmful interference to radio or television reception, which can be determined by turning the equipment off and on, the user is encouraged to try to correct the interference by one or more of the following measures:

- ♦ Reorient or relocate the receiving antenna.
- ♦ Increase the separation between the equipment and receiver.
- ♦ Connect the equipment to an outlet on a circuit different from that to which the receiver is connected.
- ♦ Consult the dealer or an experienced radio/TV technician for help.

The use of shielded cables for connection of the monitor to the graphics card is required to assure compliance with FCC regulations. Changes or modifications to this unit not expressly approved by the party responsible for compliance could void the user's authority to operate this equipment.

Canadian Department of Communications Statement

This digital apparatus does not exceed the Class B limits for audio noise emissions from digital apparatuses set out in the Radio Interference Regulations of the Canadian Department of Communications.

Manufacturer's Disclaimer Statement

The information in this document is subject to change without notice and does not represent a commitment on the part of the vendor. No warranty or representation, either expressed or implied, is made with respect to the quality, accuracy or fitness for any particular purpose of this document. The manufacturer reserves the right to make changes to the content of this document and/or the products associated with it at any time without obligation to notify any person or organization of such changes. In no event will the manufacturer be liable for direct, indirect, special, incidental or consequential damages arising out of the use or inability to use this product or documentation, even if advised of the possibility of such damages. This document contains materials protected by copyright. All rights are reserved. No part of this manual may be reproduced or transmitted in any form, by any means or for any purpose without expressed written consent of its authors. Product names appearing in this document are mentioned for identification purposes only. All trademarks, product names or brand names appearing in this document are registered property of their respective owners.

Printed in Taiwan

Table of Contents

Chapter 1 Introduction	1
1-1 Product Specifications	1
1-2 Package Contents	3
1-3 Mainboard Layout	4
1-4 Jumper and Connector Reference Page Chart	4
Chapter 2 Hardware Setup	5
2-1 Introduction to Jumpers	5
2-2 Installing a PGA type CPU in a ZIF Socket.....	6
2-3 CPU Jumper Configuration	7
2-4 Connector and Jumper Settings	10
2-5 Main Memory Configuration	16
Chapter 3 Award BIOS Setup Program	19
3-1 Standard CMOS Setup	20
3-2 BIOS Features Setup	23
3-3 Chipset Features Setup	26
3-4 Power Management Setup	28
3-5 PnP/PCI Configuration	32
3-6 Load Setup Defaults	34
3-7 Integrated Peripherals	35
3-8 Supervisor Password & User Password Setting	37
3-9 IDE HDD Auto Detection	39
3-10 Save and Exit Setup	39
3-11 Exit Without Saving	39
Chapter 4 Mainboard Software Guide	41
- VIA ACPI Patch for Win 95	
- VIA IDE Bus Master Drivers for Win95 and WinNT	
- VIA AGP VxD Drivers for Win 95	
- Trend Antivirus Utility for Win95	
- Shepherd System Monitoring Software for Win95 OR Genesys System Monitoring Software for Win95/WinNT	
- Award Flash Utility	
- Award DMI Configuration Utility	

Feature Explanations

Software Power-Off Control	11
Power-On By Modem	11/32
Over-ride Power Button Connector	12
Poly-fuse Over Current Protection	14
Flash BIOS Protection	27
Power-On By Alarm	32
Quick Connector and Jumper Reference	22-A
Appendix I On Board I/O Addresses & IRQ Maps	43
Appendix II FAN78-SMART Technology Upgrade Kit	45
Reader's Feedback	47



Memo

Introduction

1-1 Product Specifications

□ CPU

- Supports up to 200MHz Intel Pentium® processors and up to 233MHz Pentium® processors with **MMX™** technology
- Supports Intel Pentium® P54CTB **OverDrive** processors
- Supports PR120+ ~ PR200+ Cyrix/IBM 6x86™ (processor rev. 2.7 or later)/6x86L™ processors and PR166+ ~ PR233+ **6x86MX™** processors
- Supports PR75 ~ PR166 AMD-K5™ processors and up to 266 MHz **K6™** processors
- Supports 180 ~ 200MHz IDT **WinChip C6** processors
- Supports 60/66 MHz system clock speeds
- 321-pin ZIF Socket 7
- High efficiency **Switching Power Module**



Supports 68/75MHz system clock for over-clocking possibility

□ Cache Memory

- Standard 512KB (64k*64x1) Pipelined Burst SRAM on board

□ Main Memory

- Two 5V 72-Pin SIMM sockets support 4/8/16/32MB, 32/36-bit, DRAM memory modules
- Two 3.3V unbuffered 168-pin DIMM sockets support 8/16/32/64/128MB, 64/72-bit DRAM memory modules
- Supports Synchronous(12ns or faster)/EDO/FPM(70ns or faster) DRAM modules
- Maximum 256MB memory size

□ Chipset

- **VIA VP3** (82C597AT/82C586B) two chip PCIs et

□ I/O Slots

- Three 16-bit ISA slots
- Three 32-bit PCI slots (all are Master Mode, PCI 2.1 compliant)
- One 124-pin AGP slot (Accelerated Graphics Port v1.0 compliant)

❑ **Boot Block Flash BIOS**

- Award System BIOS supports PnP, APM, DMI & multi-device booting such as HDD (IDE, SCSI), CD-ROM, LS120, ZIP-ATAPI
- Includes **Trend ChipAway Virus** for a virus-free system boot-up

❑ **On Board Ultra I/O Functions**

- ITE 8661 I/O chip
- One floppy disk drive connector supports up to 2.88MB, Japanese 3 Mode, and 1Mbps transfer rates
- Two 16550A compliant serial ports
- One Standard/ECP/EPP parallel port
- Supports up to 115.2kbps IrDA IR function

❑ **Two Ultra DMA-33 PCI IDE Ports**

- Supports up to PIO Mode 4, Multi-word DMA Mode 2 & Ultra DMA-33 timings
- Complete Bus Master Drivers for well-known multi-tasking operating systems

❑ **Two Channel USB Ports**



Under compatibility testing with different peripherals

❑ **PCB Dimension**

- Baby-AT form factor, 220mm x 230mm, 4-layer PCB
- Five mounting holes

❑ **Green PC**

- Meets EPA Green PC standard: power consumption under 30W in Doze, Standby or Suspend modes

❑ **Advanced Management Capability**

- Supports Software power off control, Over-ride power button, Power-on by modem, Power-on by alarm, etc.
- Poly-fuse over-current protection for USB and keyboard
- Flash BIOS protection

1-2 Package Contents

This product comes with the following components:

- One mainboard
- One 9-pin serial port and 25-pin parallel port ribbon cable with bracket (Figure 1-1)
- One 25-pin serial port ribbon cable with bracket (Figure 1-2)
- One 40-pin IDE connector ribbon cable (Figure 1-3)
- One 34-pin floppy disk drive ribbon cable (Figure 1-4a) or (Figure 1-4b)
- Optional USB kit with PS/2 mouse, infrared and two USB ports (Figure 1-5)
- One CD-ROM disk that includes
 - Award Flash EPROM Utility, Award DMI Utility
 - VIA IDE Bus Master Drivers for Win95 and WinNT
 - VIA ACPI Patch
 - VIA AGP VxD Drivers for Win95
 - Shepherd System Monitoring Software for Win95 OR Genesys System Monitoring Software for Win95/WinNT
 - Trend PC-cillin Anti-virus v3.0 (OEM) Utility for Win95 in eight different languages
- One User's Manual

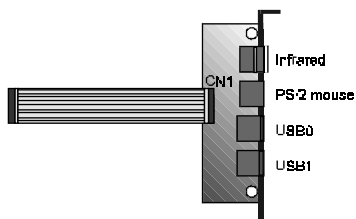
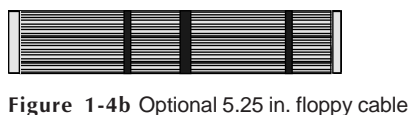
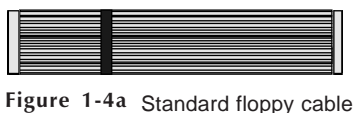
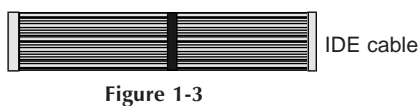
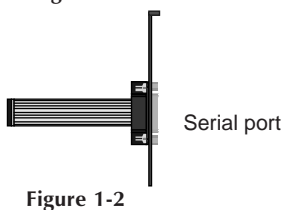
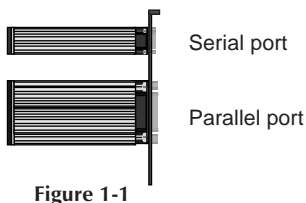

1-3 Mainboard Layout

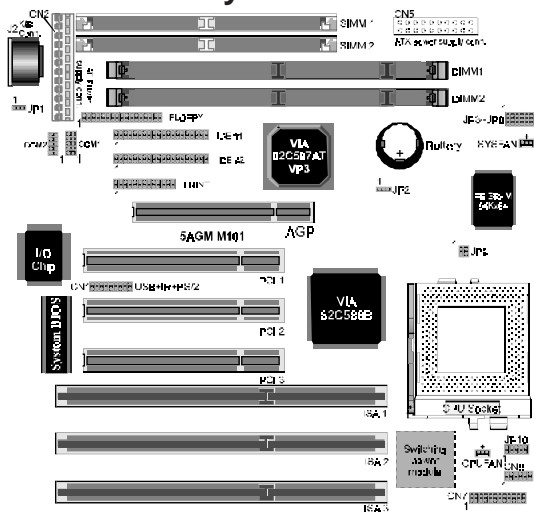

1-4 Jumper and Connector Reference Page Chart

Jumper & Connector No.	Function	Page
J2	Keyboard connector	14
JP1	AT/ATX power supply jumper	10
JP2	Clear CMOS data jumper	11
JP3-5	System frequency jumpers	7/9
JP6-8	System frequency ratio jumpers	7/9
JP9	Reserved for factory	--
JP10	CPU voltage jumpers	8/9
CN1	PS/2 mouse, USB, Infrared connector	14
	PS/2 mouse connector	15
	USB connector	15
	Infrared connector	14
CN2	AT Power supply connector	10
CN5	ATX Power supply connector	10
CN6	FAN-78 connector	45
CN7	Front panel connector set	12/13
	Keyboard lock & Power indicator LED connector	12
	System reset switch connector	13
	Speaker connector	13
	Green switch & Green LED connector	13
	Turbo LED connector	13
	IDE activity LED connector	13
	Override power button (for ATX power supply)	12
SYSFAN	System cooling fan connector	11
CPUFAN	CPU cooling fan connector	11

Chapter 2

Hardware Setup

If your mainboard has already been installed in your computer you may still need to refer to this chapter if you plan to upgrade your system's hardware.



Be sure to disconnect the power cable from the power source before performing any work on your mainboard, i. e. installing a CPU, memory module, changing a jumper setting, adding or removing expansion cards etc. Not doing so may result in electrical shock or severe damage to your mainboard and peripherals!

2-1 Introduction to Jumpers

Jumpers are used to select between various operating modes. A jumper consists of a row of gold colored pins that protrude from the surface of the mainboard. It is important not to confuse jumpers with connectors or headers.



Putting jumper caps on anything that is not a jumper may result in damaging your mainboard. Please refer to Section 1-3, Mainboard Layout, for the location of jumpers on your mainboard.

As indicated in Figure 2-1 below, a cap is used to cover the pins of a jumper, resulting in shorting those pins that it covers. If the cap is removed from the top of the pins, the jumper is left "open." The number 1 shown both in the diagram below and in all multiple pin jumper and header diagrams in this manual indicates the pin designated with the number 1. The numbering of the remaining pins follows in sequence.

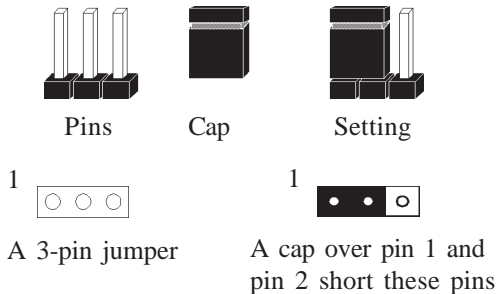

Figure 2-1

2-2 Installing a PGA type CPU in a ZIF Socket

The Intel Socket 7, designed for the Pentium processor, has been incorporated as a standard mainboard specification and is compatible with AMD and Cyrix CPUs. To insert your CPU into Socket 7 please do the following:

1. Locate a small dot marked on the top surface of the CPU close to one of its corners. The same corner will also be cut off, leaving a noticeable notch in the CPU's corner. These markings indicate Pin 1 of the CPU. See Figure 2-2.

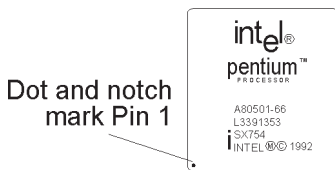

Figure 2-2 The markings on top of a CPU

2. Pull up the lever of Socket 7 so that it is perpendicular with the surface of the mainboard. Gently insert the CPU with Pin 1 at the same corner of Socket 7 that contains the end of the lever. Allow the the weight of the CPU to push itself into place. Do not apply extra pressure as doing so may result in damaging your CPU. Snap the lever back into place. See Figure 2-3.

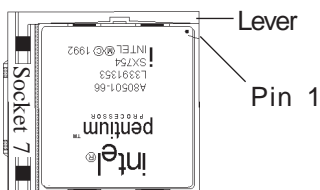

Figure 2-3 Inserting a CPU into Socket 7



Installing a heat sink and cooling fan on top of your CPU is necessary for proper heat dissipation. Failing to install these items may result in overheating and possible burn-out of your CPU.

2-3 CPU Jumper Configuration

Frequency Configuration

If you install a CPU on this mainboard, you must set **JP 3-5** for **System Frequency** and **JP 6-8** for **CPU Bus Frequency Ratio**. See Figure 2-4 CPU/System Frequency Jumper Settings.

CPU Bus Frequency & Frequency Ratio Configuration

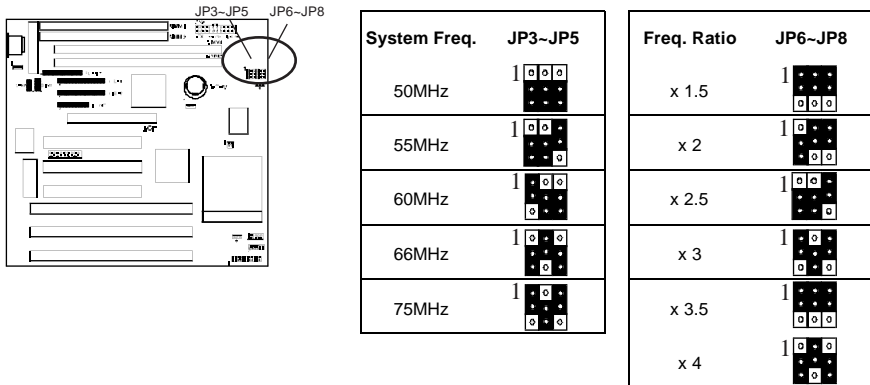

Figure 2-4 System Frequency Jumper Settings

* CPU Speed = Frequency ratio x System Frequency

Overclocking

Operating a CPU at a higher frequency than its specification allows is called overclocking. If the CPU frequency is set at a higher frequency than its specification allows, it may or may not run at that frequency, depending on the quality of the CPU and the extent to which the the frequency has been overset. The mainboard manufacturer highly discourages overclocking as it may result in data loss, CPU burn-out, system failure, etc.

Voltage Configuration

There are two major processor types in general use--single and dual voltage processors. Most single voltage processors such as Pentium, AMD-K5, and Cyrix 6x86 processors use a single voltage value of 3.5v for both core and I/O voltage settings. Most dual voltage processors such as Pentium processors with MMX technology and Cyrix 6x86L processors use a dual voltage value of 2.8v for core and 3.3v for I/O voltage settings. To make the voltage setting for single and dual voltage processors, simply set **JP10** according to the table on the next page. The voltage range supported by this mainboard is detailed in Figure 2-5 below.







Vcore	JP10
2.2V	1 
2.8V	1 
2.9V	1 
3.2V	1 
3.3V	1 
3.5V	1 

Figure 2-5 Voltage Jumper Settings

CPU-type		CPU Power Voltage			System freq.		Freq. ratio							
		I/O Vcc	Core Vcc	JP10	MHz	JP3-JP5	Spee rate	JP6-JP8						
Intel/ AMD	P54C-90, K5-PR90	3.5			60		x1.5							
	P54C-120, K5-PR120 @90MHz						x2							
	P54C-150, K5-PR150 @105MHz						x2.5							
	P54C-100, K5-PR100						x1.5							
	P54C-133, K5-PR133 @100MHz						x2							
	P54C-166, K5-PR166 @116.7MHz						x2.5							
Intel	P54C-200	3.3	2.8		66		x3							
	Pentium w/MMX 166MHz						x2.5							
	Pentium w/MMX 200MHz						x3							
	Pentium w/MMX 233MHz						x3.5							
Cyrix	6x86-PR150 ⁺ @120MHz	3.5			60		x2							
	6x86-PR166 ⁺ @133MHz								3.3	2.8		66		
	6x86L-PR166 ⁺ @133MHz													75
	6x86L-PR200 ⁺ @150MHz	60												
	6x86MX-PR166 ⁺ @150MHz			2.9		66								
	6x86MX-PR166 ⁺ @133MHz													
	6x86MX-PR200 ⁺ @166MHz	x2.5												
	6x86MX-PR200 ⁺ @150MHz								75					
AMD	K6/166	3.3	2.9		66		x2.5							
	K6/200						x3							
	K6/233						x3.5							

2-4 Connector and Jumper Settings

Connectors are used to link the system board with other parts of the system, including the power supply, the keyboard, and the various controllers on the front panel of the system case.



The power supply connector is the last connection to be made while installing a mainboard. Before connecting the power supply, please make sure it is not connected to the power source.

AT/ATX Power Supply Jumper (JP1)

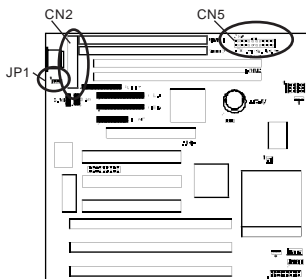

1  AT Power 1  ATX Power

This mainboard supports two kinds of power connectors and requires a power supply of at least 200 watts. If you want to use an AT power supply, short pins 1 and 2 with the jumper cap. If you want to use an ATX power supply, short pins 2 and 3 with the jumper cap.

AT Power Supply Connector (CN2)

Most power supplies have two sets of six-wire leads. Making sure the black wires of each lead are in the center, plug both leads into the AT power supply connector. The power supply requirement is as follows:

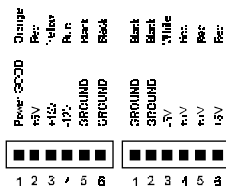

Output voltage	Regulation tolerance
+5 Vdc	± 5%
-5 Vdc	± 10%
+12 Vdc	± 5%
-12 Vdc	± 10%

ATX Power Supply Connector (CN5)

The ATX power supply provides a single 20-pin connector interface which incorporates standard +/-5V, +/-12V, optional 3.3V and soft-power signal.

The Soft-power signal, a 5V trickle supply of at least 10mA, is continuously supplied when AC power is available. When the system is in the Soft-Off mode, this trickle supply maintains the system in its minimum power state.

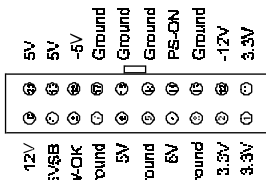

Software Power-Off Control

This mainboard can be powered down using the Windows 95 Software Power-Off function. To power down your computer, click the START button on the Windows 95 task bar. Select "Shut Down The Computer" and the system turns off. The message "It is now safe to turn off your computer" will not be shown when using this function.

Power-On By Modem

While in Soft-off state, if an external modem ring-up signal occurs, the system turns on and can be remotely accessed. Please enable the Power on by Modem function in BIOS's Power Management menu to activate this function. (See Section 3-4)

CPU/System Cooling Fan Connectors (CPUFAN/SYSFAN)

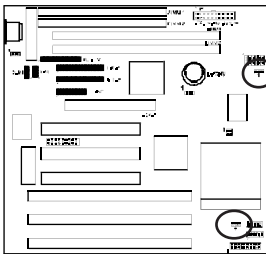

These added connectors allow the fans to draw their power from the mainboard instead of the disk drive connector. These fan connectors are available because some systems have all the disk drive power connectors in use.



Clear CMOS Data Jumper (JP2)

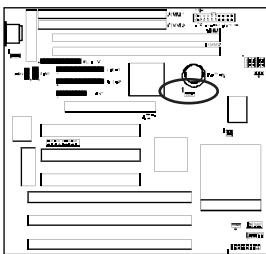

1 Default 1 Clear CMOS Data

To clear the contents of the CMOS, please follow the steps below.

1. Disconnect the system power supply from the power source.
2. Set the jumper cap at location 2~3 for 5 seconds, then set back to the default position.
3. Connect the system's power and then start the system.
4. Enter BIOS, load the setup default settings in the CMOS Setup Utility Menu and then set the system configuration in the Standard CMOS Setup menu.

Front Panel Connector Set (CN7) A through G

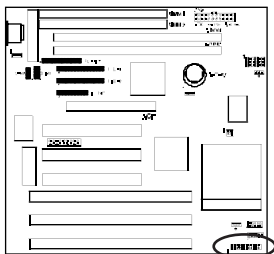

A. Over-ride Power Button Connector

The power button on the ATX chassis can be used as a normal power switch as well as a button to activate Advanced Power Management Suspend mode. This mode is used for saving electricity when the computer is not in use for long periods of time. The Soft-OFF by PWRBTN function in BIOS's Power Management Setup must be set to "Delay 4 Sec." to activate this function. (See Section 3-4)

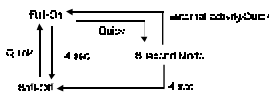
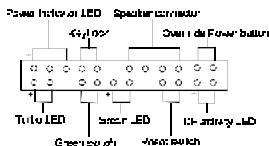

Over-ride Power Button Operation

When the Soft-off by PWRBTN function is enabled, pushing the power button rapidly will switch the system between Full-On and Suspend mode. Pushing the button rapidly again or any occurrence of external activity such as pressing a key on the keyboard will bring the system back to Full-On. Pushing the button while in Full-On for more than 4 seconds will switch the system to Soft-off and pushing the button again rapidly will turn the system back to Full-on. See Over-ride Power Button Operation diagram.

B. Keyboard Lock & Power Indicator LED Connector

Plugging this connector into the lock on the front panel of the system case allows the lock to enable or disable the keyboard. This function provides limited security against casual intruders. The power indicator LED shows the system's power status and will flash when the system is in Green mode (Suspend).

Pin	Definition
1	+5V DC
2	Not Connected
3	Ground
4	Keylock
5	Ground

C. Green Switch/Green LED Connector

Some ATX cases provide a Green switch which is used to put the system in Suspend mode. In suspend mode, the power supply to the system is reduced to a trickle, the CPU clock is stopped, and the CPU core is in its minimum power state. The system is woken up whenever the keyboard or mouse is touched or the Green button is pressed again. The system resumes in different ways as defined by "Power Management Setup" screen in BIOS.

D. Speaker Connector

Pin	Definition
1	Speaker Signal
2	GND
3	GND
4	+5V DC

E. System Reset Switch Connector

This connector should be connected to the reset switch on the front panel of the system case. The reset switch allows you to restart the system without turning the power off.

Pin	Definition
1	System
2	GND

F. IDE Activity LED Connector

The IDE activity LED lights up whenever the system reads/writes to the IDE devices.

G. Turbo LED Connector

This mainboard does not have turbo/de-turbo speed mode. Even though this function does not exist, the turbo LED will light when the LED is connected and the turbo button is pressed.

Change CPU Speed with the Keyboard

Use the following commands to change the CPU speed between turbo/de-turbo.

Set to low speed [CTRL][ALT][-]
 Set to high speed (turbo) [CTRL][ALT][+]

AT Keyboard Connector (J2)

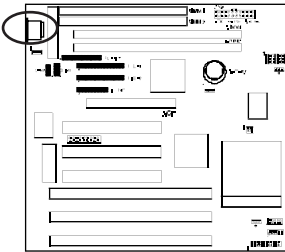

Pin	Definition
1	Keyboard Clock
2	Keyboard Data
3	(None)
4	Ground
5	+5V DC

Keyboard Connector/Pin Definitions

Poly-fuse Over Current Protection

The poly-fuse protects the system from dangerous voltages the system might be exposed to via the keyboard or USB connectors. In case of such exposure, the poly-fuse will immediately be disconnected from the circuit, just like a normal fuse. After being disconnected for a certain period of time, the poly-fuse will return to its normal state, after which the keyboard or USB can function properly. Unlike conventional fuses the poly-fuse will not have to be replaced, relieving the user wasted time and inconvenience.

USB Kit Connector (CN1) A through C

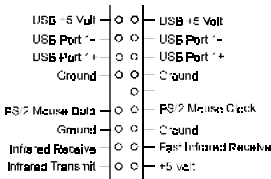

The USB Kit connector is a combination of of USB, PS/2 mouse, and Infrared functions grouped on the same connector. The USB Kit (Figure 1-5) is installed in a back panel of the chassis and is connected to the USB Kit connector with an 18-pin cable.

A. Infrared Connector

If the IR Address Select function in BIOS's Integrated Peripherals menu is not set at disabled, the COM2 port will support IR functions. (See Section 3-7)

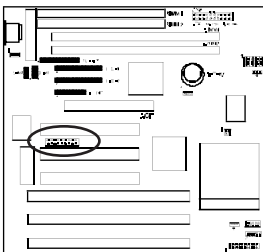

Pin	Definition
1	Ir-Tx
2	Ir-Rx
3	Not Connected
4	Vcc (+5V)
5	GND
6	Not Connected
7	Not Connected
8	Not Connected

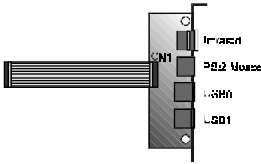

B. PS/2 Mouse Connector

If a PS/2 mouse is used, BIOS will automatically detect and assign IRQ12.



Pin	Definition
1	Data
2	Not Connected
3	Ground
4	+5V (fused)
5	Clock
6	Not Connected

C. Dual Channel USB(Universal Serial Bus) Connector

Enable the OnChip USB function in BIOS's Integrated Peripherals Menu if you want to use a USB keyboard. (See Section 3-7) Other USB devices do not require the enabling of this function. USB is an open industry standard, providing a simple and inexpensive way to connect up to 125 devices to a single computer port. Keyboards, mice, tablets, digitizers, scanners, bar-code readers, modems, printers and many more can all be used at the same time.

USB is a dynamically reconfigurable serial bus with an elementary data rate of 12Mbps, based on off the shelf, low cost micro-controller technology. It's modular layered software protocol supports sophisticated devices and application programs.

This board contains a USB Host controller and includes a root hub with two USB ports (meets USB Rev 1.0 spec.). Two USB peripherals or hub devices are able to be connected.



Compatibility with different USB peripherals is still being tested.

2-6 Main Memory Configuration

The DRAM memory system on board consists of 3 banks, and the memory range is 8 ~ 256 MBytes. You must install 2 SIMM modules (same size, same speed, either single or double sided) in each bank at a time. It does not matter which bank you install first.

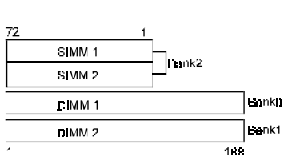

SIMM	72-pin 5V SIMM	Qty.
Bank2 (SIMM1,SIMM2)	4/8/16/32/64 FPM or EDO SIMM (DIMM sockets must be empty)	x2
DIMM	168-pin 3.3V unbuffered DIMM	Qty.
Bank0 (DIMM1)	8/16/32/64/128 MB EDO or SDRAM (SIMM sockets must be empty)	x 1
Bank1 (DIMM2)	8/16/32/64/128 MB EDO or SDRAM (SIMM sockets must be empty)	x 1

DRAM Specifications

Types Supported

FP(Fast Page), EDO(Extended Data Output) and Synchronous DRAM

Speed requirement

FP/EDO: 70-ns (or faster) for 50 or 60MHz system frequency and 60-ns for 66MHz system frequency.

SDRAM: 10/12ns

Module types & sizes

4/8/16/32/64 MBytes, single/double-sided, 5v SIMM
8/16/32/64 MBytes, single/double-sided, 3.3v DIMM

Parity

Both parity and non-parity modules may be used however the parity function is not supported by this mainboard.



Most SDRAM will be 3.3V only (i.e. SDRAM I/O pins will not be 5V tolerant). **It is not recommended to mix 3.3V EDO/SDRAM DIMM with 5V EDO/FPM SIMM.**



Because 64/128MB DIMM is not yet mainstream, the compatibility of 64/128MB DIMM can not be 100% guaranteed.



Due to loading anomalies, using DIMM with an 'n x 4' DRAM base on this mainboard is not recommended. For example, a DIMM that uses sixteen 16Mb x 4 devices should not be used.



This mainboard supports 3.3v, unbuffered, 4-clock, SDRAM DIMM only. Buffered, 5V, or 2-clock SDRAM DIMMs should not be used.

This board has two DIMM (Dual-in-line Memory Module) sockets to support SDRAM type DRAM and has the better optimized read timings (7-1-1-1). The DIMM sockets will quickly replace SIMM as the next module standard for the PC industry and will become the memory subsystems standardized 64-bit data interface. Recently, JEDEC committee passed the unbuffered DIMM pinout specification as a standard for higher speed transfer. The unbuffered DIMM allows for SDRAM, EDO and FPM DRAM compatibility as well as pinouts for x64, x72 with parity, x72 with ECC and x80 ECC. The unbuffered DIMM is distinguished by the keyed notch lying to the right of the centerline of the DRAM key position as shown in the figure below.

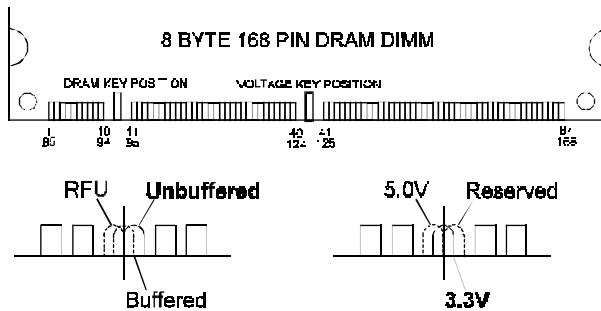



Memo

Chapter 3

Award BIOS Setup Program

Award's BIOS ROM has a built-in setup program that allows users to modify the basic system configuration. This information is stored in CMOS RAM so that it can retain the setup information, even when the power is turned off.

When you turn on or reboot the system, press the Delete key to enter the Award BIOS setup program. The primary screen as shown in Figure 3-1 is a list of the menus and functions available in the setup program. Select the desired item and press enter to make changes. Operating commands are located at the bottom of this and all other BIOS screens. When a field is highlighted, on-line help information is displayed on the left bottom edge of the screen.

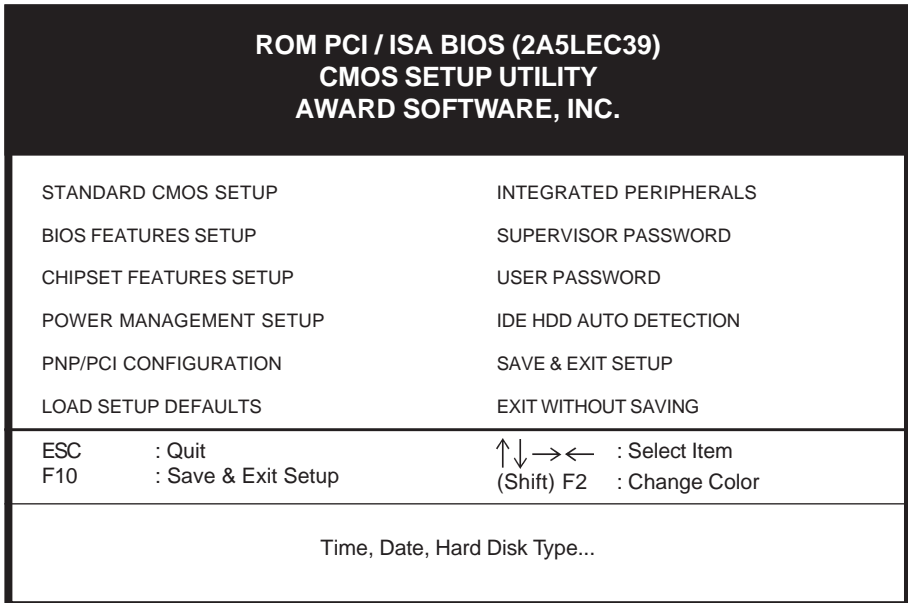

Figure 3-1 Setup Program Initial Screen

3-1 Standard CMOS Setup

The Standard CMOS Setup allows users to configure system components such as hard disk drive, floppy disk drive and video display as well as date, time and boot-up error signaling. This configuration menu should be changed when installing a mainboard for the first time, changing hardware in your system such as the HDD, FDD, video display, or when the CMOS data has been lost or contaminated. Choose the Standard CMOS Setup option from the CMOS Setup Utility menu (Figure 3-1) to display the following screen. When a field is highlighted, on-line help information is displayed on the left bottom edge of the screen.

ROM PCI / ISA BIOS (2A5LEC39)									
STANDARD CMOS SETUP									
AWARD SOFTWARE, INC.									
Date (mm : dd : yy) : Fri, July 25 1997									
Time (hh : mm : ss) : 9: 14: 43									
HARD DISKS	TYPE	SIZE	CYLS	HEAD	PRECOMP	LANDZ	SECTOR	MODE	
Primary Master	: Auto	0	0	0	0	0	0	Auto	
Primary Slave	: Auto	0	0	0	0	0	0	Auto	
Secondary Master	: Auto	0	0	0	0	0	0	Auto	
Secondary Slave	: Auto	0	0	0	0	0	0	Auto	
Drive A	: 1.44M, 3.5in.								
Drive B	: None								
Video	: EGA/VGA								
Halt On	: All Errors								
						Base Memory : 640K			
						Extended Memory : 15360K			
						Other Memory : 384K			
						Total Memory : 16384K			
ESC	: Quit	↑↓→←			: Select Item			PU/PD/+/- : Modify	
F1	: Help	(Shift) F2			: Change Color				

Figure 3-2 Standard CMOS Setup Screen

Date/Time

Set the date and time. Do not skip this function as all of your timed events such as power management, saving files, etc. are based on this timer.

Hard Disk Setup (Primary/Secondary; Master/Slave)

This category identifies up to four IDE hard disk drives that have been installed in the computer. This section does not show information on other IDE devices such as CD-ROM drives or other hard drive types such as SCSI drives.

Type (Auto/User/None): Use the fields under the Type column to determine the method you will use to configure the IDE devices. If you choose Auto, BIOS will automatically detect and make optimal settings for most IDE hard drives.



The mainboard manufacturer recommends that you choose Auto for all drives.

Choose User to define your own drive type manually. You must enter values indicated in the table below into each drive parameter field. This information should be included in the documentation from your hard disk vendor or system manufacturer:

TYPE	Setting method
CYLS	Number of cylinders
HEAD	Number of heads
PRECOMP	Write precompensation cylinder
LANDZ	Landing zone
SECTOR	Number of sectors
MODE	Mode type

Table 3-1 Hard Disk Drive Parameters

Cyls/Head/Sector: The number of Cylinders, Heads, and Sectors can usually be found written on the top of the hard disk. If you have a relatively new hard drive, entering this information alone is usually sufficient for normal hard disk operation. The hard disk will not work properly if you enter improper information for these categories.

Precomp: Older hard drives (i.e., MFM or RLL drives) have the same number of sectors per track at the innermost tracks as at the outermost tracks. Thus, the data density at the innermost tracks is higher and the bits are lying closer together. Even though the physical size of a sector gets progressively smaller as the track diameter diminishes, each sector must still hold 512 bytes. Write precompensation circuitry compensates for the difference in sector size by boosting the write current for inner track sectors.

Landz: This defines the address of the landing zone and is only used for older hard drives which do not have an auto-parking feature.

Mode: If the Type value is not None for any device, you must set the Mode value for that device. There are four different Mode values: Auto, Normal, Large, and LBA.

Auto - BIOS detects and enters the IDE drive type during bootup.

Normal - for IDE drives that meet the old IDE specification which support a maximum capacity of 528MB (1024 cylinders, 16 heads, and 63 sectors).

Large - for IDE drives that do not support LBA and have more than 1024 cylinders. Try this setting if your hard disk does not operate properly with

the LBA setting. Large mode is not supported by all operating systems, i.e., only certain versions of DOS support large mode.

LBA - (Large/Logical Block Addressing) With LBA, the IDE controller transforms the data address described by sector, head, and cylinder number into a physical block address, significantly improving data transfer rates. This mode is for drives with greater than 1024 cylinders and between 528MB and 8.4GB in size. This protocol is the current common standard.

Choose None for Type if there are no IDE HDD devices in your system.

-  You can use the IDE HDD Auto Detection function to auto detect your hard drive parameters. Using this function will automatically insert the parameters discussed under Hard Disk Setup and will indicate User for the Field value. Please see Section 3-9 for more information.

Floppy Disk Drives

Choose the memory capacity and disk size that corresponds with that of your floppy disk drive(s).

Video

Select the type of video adapter present in your system. You can ignore this setting if you are using a VGA monitor since VGA BIOS automatically configures this setting.

Halt

When the system is powered on, BIOS performs a series of diagnostic tests called POST (Power On Self Test). This function stops the computer if BIOS detects a hardware error. You can tell BIOS to halt on all errors, no errors, or not to halt on specific errors.

3-2 BIOS Features Setup

By choosing the BIOS Features Setup option from the CMOS Setup Utility menu (Figure 3-1), the screen below is displayed. This sample screen contains the manufacturer's default values for the mainboard.

ROM PCI / ISA BIOS (2A5LEC39)			
BIOS FEATURES SETUP			
AWARD SOFTWARE, INC.			
Virus Warning	: Disabled	Video BIOS Shadow	: Enabled
CPU Internal Cache	: Enabled	C8000 - CBFFF Shadow	: Disabled
External Cache	: Enabled	CC000 - CFFFF Shadow	: Disabled
Quick Power On Self Test	: Enabled	D0000 - D3FFF Shadow	: Disabled
Boot Sequence	: A,C,SCSI	D4000 - D7FFF Shadow	: Disabled
Swap Floppy Drive	: Disabled	D8000 - DBFFF Shadow	: Disabled
Boot Up Floppy Seek	: Enabled	DC000 - DFFFF Shadow	: Disabled
Boot Up NumLock Status	: On		
Boot Up System Speed	: High		
Typematic Rate Setting	: Disabled		
Typematic Rate (Chars/Sec)	: 6		
Typematic Delay (Msec)	: 250		
Security Option	: Setup		
PCI/VGA Palette Snoop	: Disabled		
OS Select(For DRAM>64MB):	Non-OS2		
		ESC : Quit	↑↓→← : Select Item
		F1 : Help	PU/PD/+/- : Modify
		F5 : Old Values	(Shift) F2 : Color
		F7 : Load Setup Defaults	

Figure 3-3 BIOS Feature Setup Screen

A. VIRUS PROTECTION

Virus Warning

When Enabled, BIOS activates a warning message to the user when any program (i.e., a virus) attempts to access the boot sector or hard disk partition table. The user is able to intervene by running an anti-virus program. This function only protects the boot sector and not the entire hard drive.

B. CACHE CONTROL

CPU Internal Cache/External Cache

Cache memory is much faster than conventional DRAM system memory. These fields allow you to enable or disable the CPUs Level 1 built-in cache and Level 2 external cache. Both settings are left enabled to significantly increase the performance of your computer.

C. BOOT UP FEATURES

After turning on the system, BIOS will perform a series of device initializations and diagnostic tests discussed below.

Quick Power On Self Test (POST)

Enable this function to reduce the amount of time required to run the POST (Power On Self Test). BIOS saves time by skipping some items during POST. It is recommended that you disable this setting. Discovering a problem during bootup is better than losing data during your work.

Boot Sequence

This option sets the sequence of drives BIOS attempts to boot from after POST completes. BIOS will search these drives for an operating system.

Swap Floppy Drive

Enabling this function will swap the floppy drive assignment so that drive A will function as drive B, and drive B will function as drive A. Note that the boot sequence assignment mentioned directly above does not include booting from floppy drive B. This function is useful if floppy drives B and A are of a different format and you want to boot from floppy drive B.

Boot up Floppy Seek

During POST, BIOS will determine if the installed floppy disk drive has 40 or 80 tracks. A 360K drive has 40 tracks and 720K, 1.2M and 1.44M drives have 80 tracks. All modern floppy disk drives have 80 tracks.

Boot Up NumLock Status

This function defines the keyboard's numberpad as number keys or arrow keys.

Boot Up System Speed

This function determines the CPU speed while in non-protected mode under DOS. Set to High for regular CPU speed and low for decreased CPU speed. This function is used for applications such as games that require decreased CPU speed.

D. KEYBOARD INTERFACE

Typematic Rate Setting

When enabled, you can set the following two typematic control items. When disabled, keystrokes are determined arbitrarily by the keyboard controller in your system.

Typematic Rate (Chars/Sec)

The typematic rate sets the rate at which characters on the screen repeat when a key is pressed and held down.

Typematic Delay (Msec)

The typematic delay sets how long after you press a key that a character begins repeating.

E. Security Option

The Supervisor and/or User Password functions shown in Figure 3-1 must be set to take advantage of this function. See Section 3-8 for password setting information. When the Security Option is set to System, a password must be entered to boot the system or enter the BIOS setup program. When the Security Option is set to Setup, a password is required to enter the BIOS setup program.

F. PCI/VGA Palette Snoop

Some non-standard VGA cards or MPEG video cards may not show colors properly. Setting this function to Enabled can correct this problem.

G. OS Select (For DRAM > 64MB)

If your system's DRAM is larger than 64MB and you are running OS/2, select OS/2 as the item value. Otherwise, set the item value to Non-OS/2 for all other operating systems.

H. Shadow Memory

Software such as system BIOS, video BIOS, SCSI BIOS, etc that resides in ROM (Read Only Memory) chips is called firmware. Shadowing of firmware occurs when BIOS is copied to RAM address C0000h through DFFFFh. Video BIOS loads into the C0000-C7FFF memory area when video shadowing is enabled. If an expansion peripheral in your system contains ROM-based firmware, you need to know the address range the ROM occupies to shadow it into the correct area of RAM.

Shadowing improves the firmware's performance because the firmware can be read by the CPU through the 16- or 32-bit DRAM bus as opposed to the 8-bit XT bus. However, shadowing also results in reducing the amount of high memory (640 KB to 1 MB) for loading device drivers. Shadowing is used mostly for ROM chips on ISA cards and not for PCI cards. Shadowing and playing games at the same time may result in system instability as some games access the RAM memory area being shadowed.

3-3 Chipset Features Setup

By choosing the Chipset Features Setup option from the CMOS Setup Utility menu (Figure 3-1), the screen below is displayed. This sample screen contains the manufacturer's default values for the mainboard.

ROM PCI / ISA BIOS (2A5LEC39) CHIPSET FEATURES SETUP AWARD SOFTWARE, INC.	
DIMM 1 EDO/SDRAM Timing : 70/12 ns	Flash BIOS Protection : Disabled
DIMM 2 EDO/SDRAM Timing : 70/12 ns	
SIMM 3 EDO/FP DRAM Timing: 70 ns	
SDRAM Cycle Length : 3	
DRAM Read Pipeline : Enabled	CPU Warning Temperature : 65 °C/140 °F
Cache Strategy : WT	Current CPU Temperature : 25 °C/77 °F
Cache Rd+CPU Wt Pipeline : Enabled	Current CPUFAN Speed : 3600 RPM
Read Around Write : Enabled	Current SYSFAN Speed : 3600 RPM
Cache Timing : Fastest	Current Vin (V) : 3.3
Video BIOS Cacheable : Enabled	
System BIOS Cacheable : Enabled	
Memory Hole At 15MB Addr. : Disabled	
AGP : Enabled	
AGP Aperture Size : 64M	
AGP-2X Mode : Enabled	
ESC : Quit	↑ ↓ → ← : Select Item
F1 : Help	PU/PD/+/- : Modify
F5 : Old Values	(Shift) F2 : Color
F7 : Load Setup Defaults	

Figure 3-4 Chipset Features Setup Screen



All of the above settings have been determined by the mainboard manufacturer and should not be changed unless you are absolutely sure of what you are doing. Explanation of the DRAM timing and chipset features setup is lengthy, highly technical and beyond the scope of this manual. Below are abbreviated descriptions of the functions in this setup menu. You can look on the world wide web for helpful chipset and RAM configuration information including AWARD's web site at <http://www.award.com>.

A. Video BIOS Cacheable

Enabling this function allows caching of the video BIOS ROM at C0000h-C7FFFh, resulting in better video performance. However, if any program writes to this memory area, a system error may result. Caching the video BIOS results in better performance than shadowing the video BIOS as discussed in Section 3-2.

B. System BIOS Cacheable

Enabling this function allows caching of the system BIOS ROM at F0000h-FFFFFh, resulting in better system performance. However, if any program writes to this memory area, a system error may result. Caching the system BIOS results in better performance than shadowing the system BIOS as discussed in Section 3-2.

C. Memory Hole at 15MB Addr.

Enabling this feature will reserve the 15MB to 16MB memory address space for ISA expansion cards. However, enabling this function will result in not allowing the system to have access to memory above 16MB. Please note that some expansion cards require this setting to be enabled. The default setting is Disabled.

D. AGP

This function must be enabled when using an AGP card. If you disable this function you can still use an AGP card. However, the AGP card will only have PCI card performance.

E. AGP Aperture Size

This function determines the amount of system memory that is given to the AGP card. Options range from 4MB to 256MB. This is a dynamic memory allotment in that the AGP card will only use the amount of memory that it needs. The remaining memory not in use will be available for the system to use. For example, if 16MB is allotted to the AGP card and the card only needs 8MB, the remaining 8MB will be available for system use.

F. AGP-2X Mode

Enable this setting to utilize the 2X mode (twice as fast as 1X) offered by advanced AGP cards. Your VGA card must support 2X mode in order to take advantage of the faster speed.

G. Flash BIOS Protection

The mainboard manufacturer developed BIOS protection technology that protects the System BIOS from accidental corruption by unauthorized users or computer viruses. When enabled, the BIOS data cannot be changed when attempting to update BIOS with the the FLASH utility. When disabled, the BIOS data can be updated by using the FLASH utility.

H. System Monitoring and Alerting (Optional)

These optional system health monitoring features are available when an EISCA v1.0 compliant fan is connected to the Fan 78 connector on your mainboard. Change the CPU warning temperature according to the specifications of your CPU. For more information about EISCA fans, see Appendix II of this manual.

3-4 Power Management Setup

This section provides information on the Green PC power management functions. In order to enable the power management functions, please select the Power Management Setup option from the CMOS Setup Utility menu (Figure 3-1). This sample screen contains the manufacturer's default values for the mainboard.

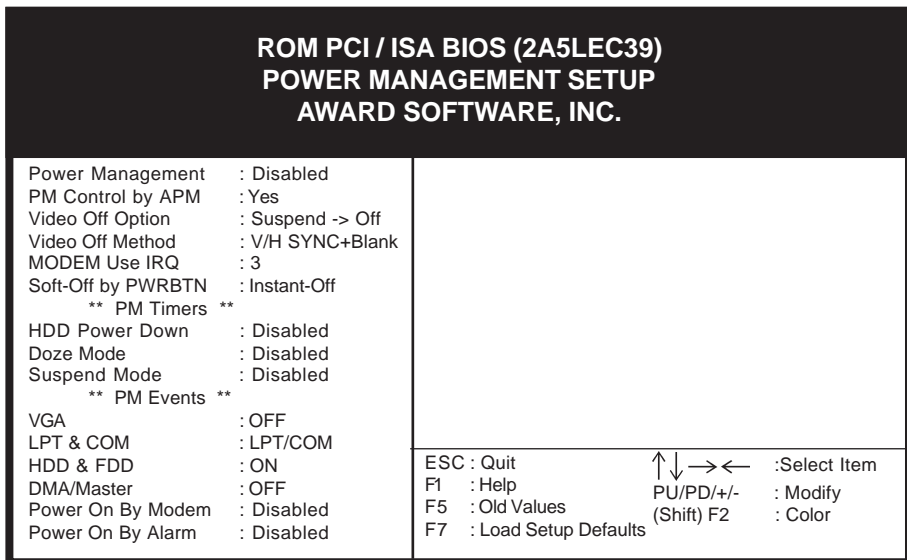

Figure 3-5 Power Management Setup Screen

A. Power Management

Power management allows the computer to save electricity when it is not in use by entering increasingly deep power saving modes as shown by the diagram below.

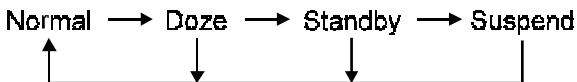

Figure 3-6 Power Saving Mode Flow Chart

The computer runs in Normal operation mode until the Doze timer expires, at which point the computer enters Doze mode. If no external activity occurs, the computer will go into Standby and Suspend modes when their respective timers expire. If external activity occurs, the computer will wake up from Power Management and return to Normal mode. To activate the function, set Power Management to Maximum Saving, User Define, or Minimum Saving described

below. For a description of the power saving modes (Doze, Standby, and Suspend) see their descriptions below.

Disabled - Turns off the Power Management functions.

Max. Saving - All timers are set at the minimum value of one minute to maximize power saving.

Min. Saving - All timers are set at the maximum value of one hour for minimal power saving.

User Define - User can configure the timer to a desired time according to the values available.

Note that enabling the Power Management function will result in enabling the HDD Power Down function (Max Saving = 15 min, Min Saving = 1 min). The HDD Power Down function is not part of the Power Management scheme as indicated in Figure 3-6. Refer to the Standby Mode, Suspend Mode, and HDD Power Down descriptions below for more information on hard drive power management.

B. PM Control by APM

This function allows software other than BIOS to control Power Management features. Enable this function in BIOS and make sure APM (Advanced Power Management) is present. For example, run the Power utility program located in the DOS directory, C:\DOS\POWER.EXE to use Power Management features under DOS. For Windows 3.1x and Windows 95, you need to install Windows with the APM feature.

C. Video Off Option

This setting determines when the monitor enters power saving mode. As the function name indicates, the monitor enters the power saving mode after the chosen event expires. The Power Management function must be enabled to use this function.

D. Video Off Method

This function serves as both a screen saver and power saver for monitors. See the next function, Video Off After, for setting the video timer.

Blank - BIOS will only blank the monitor's screen. The electricity saved in this mode is negligible and this function is only used as a screen saver to prevent screen damage while the screen is on but not in use.

V/H SYNC+Blank - The system turns off the vertical and horizontal synchronization ports, writes blanks to the VGA buffer and the monitor's electron gun turns off. This function requires a monitor with Green features in order to take advantage of the power saving function. If you enable this function and do not have a Green monitor, the result will be the same as if you had

selected Blank. This function serves as both a screen saver and an electricity saver.

DPMS Supported - Select this option if your video card supports the Display Power Management Signaling (DPMS) standard (i.e., you have a monitor that supports Green features). Use software supplied by your video subsystem to set video power management options.

E. Modem Use IRQ

If your computer has a modem, use this function to tell BIOS which IRQ is being occupied by the modem card. When the system is in Green mode, the modem requires an IRQ assignment to wake up the system and perform tasks. This assignment is compliant with the APM 1.2 specification and is to be used in coordination with APM 1.2 compliant operating systems.

F. Soft-Off by PWRBTN

When Enabled, this function allows the power button to put the system in Suspend, a power saving mode. See section 2-4 for operation instructions of the power button.

G. HDD Power Down

To enable this function, make sure the Power Management function is not set to disabled. When the HDD idle time has elapsed, BIOS sends a command to the hard disk to turn off the motor. Set a time between 1 and 15 to indicate time required to wait before the hard drive enters a power saving mode. Some old hard drives may not support this function.

H. Doze Mode

To enable this function, make sure the Power Management function is not set to disabled. If no interrupts have occurred and the Doze timer expires, system will enter Doze mode. In Doze mode, the CPU clock runs at a lower speed while all other devices operate normally.

✎ Power saving modes achieved in lower power saving states will either be maintained or enter higher power saving modes when switching to higher power saving states. For example, the CPU clock will not switch back to normal in Standby mode. It will maintain a decreased rate in Standby Mode and turn off in Suspend Mode.

I. Suspend Mode

To enable this function, make sure the Power Management function is not set to disabled. If the system runs in Dozemode and the Suspend timer expires, all devices regulated by power management will shut off and the CPU speed will be 0 MHz.

J. Power On By Modem

When enabled, a modem that receives a call will wake up the system from Soft-off or Green mode. To activate this function, you must leave your modem on and use the Software Power off. See the Software Power-Off control description in Section 2-4 of this manual.

K. Power On By Alarm

When enabled, this setting allows the system to turn back on at a designated time of the month. User must designate date of month and time of day. This function is only available when using an ATX pwer supply and Software Power-Off. See the Software Power-Off control description in Section 2-4 of this manual.

3-5 PNP/PCI Configuration

This section provides IRQ and DMA setting information. By choosing the PnP/PCI Configuration option from the CMOS Setup Utility menu (Figure 3-1), the screen below is displayed. This sample screen contains the manufacturer's default values for the mainboard.

ROM PCI / ISA BIOS (2A5LEC39) PNP/PCI CONFIGURATION AWARD SOFTWARE, INC.			
PNP OS Installed	: No	CPU to PCI Write Buffer	: Enabled
Resources Controlled By	: Manual	PCI Parity Check	: Disabled
Reset Configuration Data	: Disabled	PCI Delay Transaction	: Enabled
		FDD IRQ Can Be Free	: No
		Assign IRQ For VGA	: Enabled
IRQ-3 assigned to	: Legacy ISA		
IRQ-4 assigned to	: Legacy ISA		
IRQ-5 assigned to	: PCI/ISA PnP		
IRQ-7 assigned to	: Legacy ISA		
IRQ-9 assigned to	: PCI/ISA PnP		
IRQ-10 assigned to	: PCI/ISA PnP		
IRQ-11 assigned to	: PCI/ISA PnP		
IRQ-12 assigned to	: PCI/ISA PnP		
IRQ-14 assigned to	: Legacy ISA		
IRQ-15 assigned to	: Legacy ISA		
DMA-0 assigned to	: PCI/ISA PnP		
DMA-1 assigned to	: PCI/ISA PnP		
DMA-3 assigned to	: PCI/ISA PnP		
DMA-5 assigned to	: PCI/ISA PnP		
DMA-6 assigned to	: PCI/ISA PnP		
DMA-7 assigned to	: PCI/ISA PnP		
		ESC : Quit	↑ ↓ → ← : Select Item
		F1 : Help	PU/PD/+/- : Modify
		F5 : Old Values	(Shift) F2 : Color
		F7 : Load Setup Defaults	

Figure 3-6 PCI & ONBOARD I/O Setup Screen

A. PNP OS installed

If you want to install a PNP compatible OS (such as Windows 95) set to **Yes**.

B. Resources Controlled By

When set to Manual the system BIOS will not refer to the ESCD for IRQ & DMA information. Instead, it will refer to the items in the setup menu for assigning IRQ & DMA. When set to Auto the system BIOS will refer to the ESCD for all legacy information.



ESCD(Extended System Configuration Data) provides a detailed format of the configuration data structures stored in flash memory. Each data structure defines the resources used by a device or a card in the system. This includes legacy and PCI/ISA PnP devices.

C. Reset Configuration Data

When Enabled the system BIOS will clear/reset the ESCD during POST. After clearing the ESCD, the BIOS will then change this item's value to "Disabled." Otherwise, the ESCD data would become useless.

D. IRQ#/DMA# assign to

When resources are controlled manually, you can assign each system interrupt & DMA channel for "Legacy ISA" or "PCI/ISA PnP" card used. While using **Legacy ISA Cards** (non-PnP ISA cards), please set the necessary corresponding resources (INT#, DMA#) from "PCI/ISA PnP" to "Legacy ISA."

- ☒ All ISA non-PnP devices are legacy devices that select resources (I/O Addr., INT# or DMA#) by using hardware jumpers on these devices.
- ☒ IRQ-3/4/7/12/14/15 have been set as default for on board devices (COM2, COM1, Printer port, PS/2 mouse, IDE1 and IDE2).

E. FDD IRQ Can Be Free

This function allows users to choose if the FDD IRQ is able to be freed for use with other processes that require IRQ.

F. Assign IRQ For VGA

This function allows BIOS to make an IRQ available to VGA cards. Current VGA card models do not require this function to be enabled.

3-6 Load Setup Defaults

Load Setup Defaults loads the default system values directly from the CMOS Setup Utility menu (Figure3-1). If the stored record created by the setup program becomes corrupted and therefore unusable, these defaults will be loaded automatically when you turn on the computer.

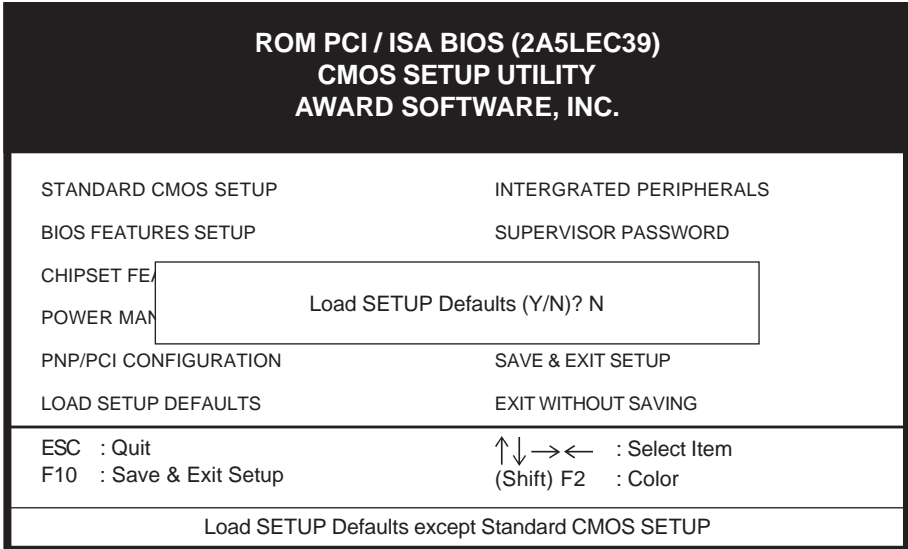

Figure 3-7 Load Setup Defaults Screen

3-7 Integrated Peripherals

This section provides information on setting peripheral devices. By choosing the Integrated Peripherals option from the CMOS Setup Utility menu (Figure 3-1), the screen below is displayed. This sample screen contains the manufacturer's default values for the mainboard.

ROM PCI / ISA BIOS (2A5LEC39) INTEGRATED PERIPHERALS AWARD SOFTWARE, INC.			
OnChip IDE First Channel	: Enabled	Onboard Parallel Port	: 378/IRQ7
OnChip IDE Second Channel	: Enabled	Parallel Port Mode	: SPP
IDE Prefetch Mode	: Enabled	OnChip USB	: Disabled
IDE HDD Block Mode	: Enabled		
IDE Primary Master PIO	: Auto		
IDE Primary Slave PIO	: Auto		
IDE Secondary Master PIO	: Auto		
IDE Secondary Slave PIO	: Auto		
IDE Primary Master UDMA	: Auto		
IDE Primary Slave UDMA	: Auto		
IDE Secondary Master UDMA	: Auto		
IDE Secondary Slave UDMA	: Auto		
Onboard FDC Controller	: Enabled		
Onboard Serial Port 1	: 3F8/IRQ4		
Onboard Serial Port 2	: 2F8/IRQ3		
IR Address Select	: Disabled		
		ESC : Quit	↑ ↓ → ← : Select Item
		F1 : Help	PU/PD/+/- : Modify
		F5 : Old Values	(Shift) F2 : Color
		F7 : Load Setup Defaults	

Figure 3-8 PCI & ONBOARD I/O Setup Screen

A. On-chip Primary/Secondary PCI IDE

Disable these settings to turn off the built-in IDE controller.

B. IDE Prefetch Mode

This mode is involved in multiple sector read/writes and improves the performance of your system. Enabling this function improves the performance of your computer.

C. IDE HDD Block Mode

Enable this mode to improve the performance of your system. Block Mode is also referred to as block transfer or multiple sector read/write. When this setting is enabled, the maximum number of block read/writes per sector supported by the the drive is detected. Most new hard drives support this mode.

D. On Board IDE Control

The following settings are used to configure the on-board IDE controller.

IDE Primary/Secondary Master/Slave PIO/UDMA

The four IDE PIO (programmed Input/Output) fields let you set a PIO mode (0-4) for each IDE device that the internal PCI IDE interface supports. Modes 0 through 4 provide successively increased performance. In Auto mode, the system automatically determines the best mode for each device.

E. On Board FDC Controller

Enabling the floppy disk controller (FDC) allows for normal use of the floppy drive connected to the mainboard. If you install an add-in FDC or the system has no floppy drive, disable this function.

F. IR Address Select

Make sure this function is not set to Disabled to activate IR functions. When this function is enabled, you must also indicate an IR Mode and designate an IRQ to be used by your IR port.

G. OnChip USB

Enable the on-board Universal Serial Bus (USB) controller if you want to connect a USB keyboard to your system. Note that if this setting is disabled, you can still temporarily use a USB keyboard during bootup so that you can enter BIOS and enable this setting. If you pass the bootup stage without enabling this function, your PS/2 keyboard will no longer work.

3-8 Supervisor Password & User Password Setting

There are four different variables that control password settings. The first two are located under the Security Option function in BIOS Features Setup Menu (Figure 3-3). When the Security Option function is set to Setup, a password is required to enter BIOS and change BIOS settings. When the Security Option function is set to System, a password is required to enter both BIOS and the the computer's operating system (for example Windows 95) found on the boot drive. This is shown in Figures 3-9 and 3-10.

The third and fourth variables are user password and supervisor password selected in BIOS (Figure 3-1). The main purpose of separating user and supervisor is to allow only the supervisor to have control over the settings in BIOS. The user, on the other hand, is only allowed to access the computer's operating system and change the user password in BIOS (See Figure 3-10 below). Note that when there is no supervisor password set, the user password controls access to all BIOS settings (See Figure 3-9 below).

A. Set Either Supervisor Password or User Password

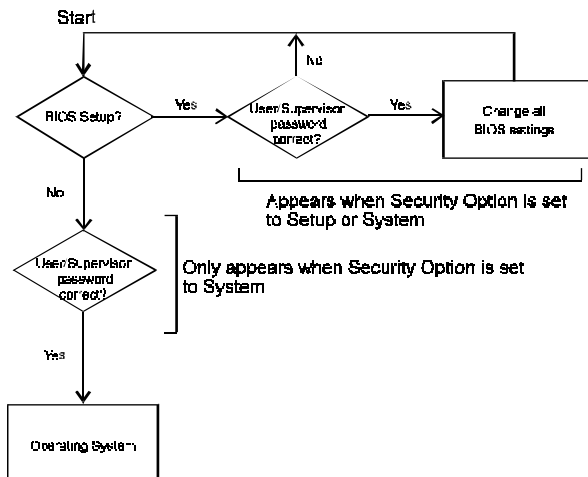

Figure 3-9 Set Either Supervisor or User Password

B. Set Both Supervisor Password and User Password

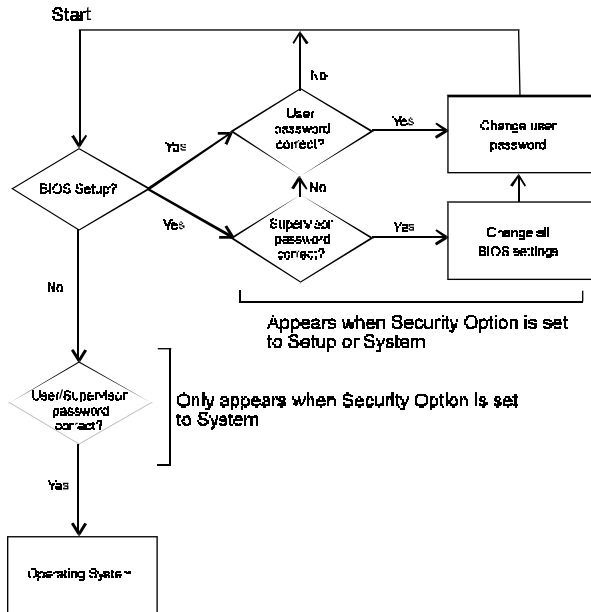

Figure 3-10 Set Both Supervisor and User Password

3-9 IDE HDD Auto Detection

This utility can automatically detect IDE hard disk type and parameters. The detection process take about 5 seconds for each physical drive. After the utility detects the disk drive, type Y and press [Enter] to automatically load the parameters in the Hard Disk section of the Standard CMOS Setup menu. Otherwise, leave the option set at N and press [Enter] or the [Esc] key to skip the detected drive. After detecting your hard drive(s), return to the Standard CMOS menu to check your settings.

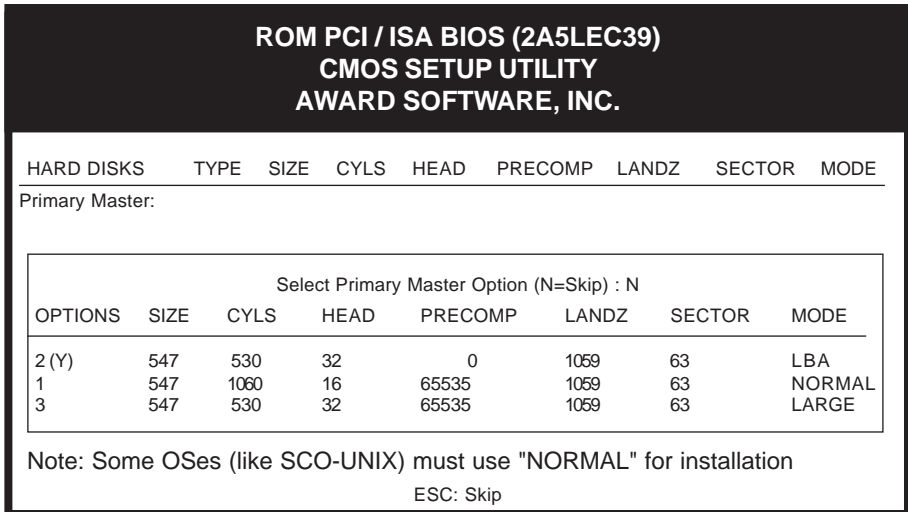

Figure 3-11 IDE HDD Auto Detection Screen

3-10 Save and Exit Setup

If you select this and type Y (for yes) followed by the [Enter] key, the values entered in the setup utilities will be recorded in the CMOS memory of the BIOS chip.

3-11 Exit Without Saving

Selecting this option and pressing Y followed by the [Enter] key lets you exit the Setup program without recording any new values or changing old ones.



Memo

Mainboard Software Guide



In the following installation instructions, drive D:\ is assumed to be your CD-ROM disk drive.

4-1 VIA ACPI Patch for Win95

Windows 95 software was written before the VIA chipset on your mainboard was designed and manufactured. Thus, the newer chipset contains information not recognized by Windows 95. This problem results in an abnormal appearance of question and/or exclamation marks in the Windows 95 Device Manager window. You can verify this problem by looking at the Windows 95 Device Manager window via the following pathway: **Start/Settings/Control Panel/System/Device Manager**. The chipset manufacturer has written a Patch file that allows Windows 95 to identify all the components of the chipset. Installing this Patch file will remove question and/or exclamation marks. However, since the performance of Windows 95 was not compromised by the lack of this patch, there will be no increase in Windows 95 performance after installation.

To use the auto-install feature to install the VIA ACPI Patch, do the following:

1. Start Windows 95.
2. Insert the CD-ROM disk that came with your mainboard into your CD-ROM drive. The CD-ROM will autorun and a software installation window will appear.
3. Click on the VIA ACPI Patch for Win95 button and follow instructions on the screen to complete the software installation.
4. Restart the computer.

To install the VIA ACPI Patch manually, click on the Setup application file located at D:\Viapatch\Setup.exe in Windows Explorer. Be sure to restart your computer after installation.

4-2 VIA IDE Bus Master Drivers for Win95 and WinNT

IDE Bus Mastering drivers are included for best IDE performance. To use the auto-install feature to install the IDE driver, do the following:

1. Start Windows 95.
2. Insert the CD-ROM disk that came with your mainboard into your CD-ROM drive. The CD-ROM will autorun and a software installation window will appear.
3. Click on the VIA IDE Bus Master Drivers button and follow instructions on the screen to complete the software installation.
4. Restart the computer.

To install the IDE driver manually, click on the Setup application file located at D:\Viaide\Setup.exe in Windows Explorer. The Setup program will determine if you are using Windows 95 or Windows NT 4.0. Be sure to restart your computer after installation.

4-3 VIA AGP VxD Drivers for Win95

VxD drivers are used in the allocation of memory resources between your AGP card and your system's main memory. The installation of this software is necessary for the proper functioning of your AGP VGA port. You must also comply with the following conditions to obtain proper functioning of your AGP port.

1. Use Windows 95 version OSR2.1 (OEM Service Release 2 plus USB supplement). If you have Windows 95 OSR2 and you would like to update to the USB supplement, obtain and install USBSUPP.EXE from Microsoft which also includes the new memory manager (VMM32.VxD) needed for the AGP DIME (Direct Memory Execute) feature.
2. Install DirectX 5.0 from Microsoft. DirectX 5.0 is the first DirectX version that supports AGP's DIME and should be supplied by your AGP VGA card manufacturer.
3. Install the AGP VGA Driver supplied by your AGP VGA card manufacturer.

To use the auto-install feature to install the VxD drivers, do the following:

1. Start Windows 95.
2. Insert the CD-ROM disk that came with your mainboard into your CD-ROM drive. The CD-ROM will autorun and a software installation window will appear.
3. Click on the VIA AGP VxD Drivers for Win95 button and follow instructions on the screen to complete the software installation.
4. Restart the computer.

To install the VxD drivers manually, click on the Setup application file located at D:\ViaVxD\Setup.exe in Windows Explorer. Be sure to restart your computer after installation.

4-4 Trend Antivirus Utility for Win95

Your CD-ROM contains PC-cillin, software used in detecting and cleaning viruses from your computer. The readme.txt file located at D:\Pccillin\readme.txt contains important information regarding the use of this software. To use the auto-install feature to install PC-cillin, do the following:

1. Start Windows 95.
2. Insert the CD-ROM disk that came with your mainboard into your CD-ROM drive. The CD-ROM will autorun and a software installation window will appear.
3. Click on the Trend Antivirus Utility button and then choose a language.
4. Follow instructions on the screen to complete the software installation.
5. Restart the computer.

To install PC-cillin manually, click on the Setup application file located at D:\Pccillin\((choose a language)\Setup.exe in Windows Explorer. Be sure to restart your computer after installation.

4-5 Shepherd System Monitoring Software for Win95 OR Genesys System Monitoring Software for Win95/WinNT



Depending on the type of packaging your system assembler ordered, you will either receive Shepherd or Genesys System monitoring software.

Shepherd or Genesys, in combination with this mainboard's system monitoring hardware, detects the rpm speed of both system and CPU fans, CPU temperature, and the input and output of one on-board voltage(Genesys detects four on-board voltages). If something goes wrong in your system, an alarm will sound and display appropriate error data in an error output window. To use the auto-install feature to install Shepherd, do the following:

1. Start Windows 95.
2. Insert the CD-ROM disk that came with your mainboard into your CD-ROM drive. The CD-ROM will autorun and a software installation window will appear.
3. Click on the Shepherd or System Monitor button.
4. Follow instructions on the screen to complete the software installation.
5. Restart the computer.

To install Shepherd manually, click on the Setup application file located at D:\Shepherd\Setup.exe in Windows Explorer. For Genesys, click on the Setup file for Genesys at D:\SysMon\Win95\Setup.exe or D:\SysMon\WinNT\Setup.exe. Be sure to restart your computer after installation.

4-6 Award Flash Utility



It is highly recommended that you make a back up copy of the old BIOS before installing the new version. In case the new version is not functional, you may reinstall the old copy. See the next page for backup instructions.

Your system is equipped with a Flash ROM which allows users to update the BIOS to a newer version without changing components. We suggest that you update BIOS using the following method--Obtain an updated version of BIOS from your mainboard vendor. In the Windows 95 or DOS environments, copy the following two programs to a formatted, bootable disk.

- A) The new version of BIOS (this is a ".bin" file).
- B) The Award Flash Utility located in the enclosed CD-ROM's root directory **D:\FLASH\AWDFLASH.EXE** (assume D is CD-ROM Drive).

Follow the instructions below to complete the BIOS upgrade.

1. Insert the disk prepared above into the floppy disk drive.
2. **Type "A(or B):\AWDFLASH"** at DOS command line and press [Enter] key.
3. You will see the setup screen as shown below.
4. Please **key in BIOS file name**. (The filename will be released from your dealer when a new up-dated BIOS is released).

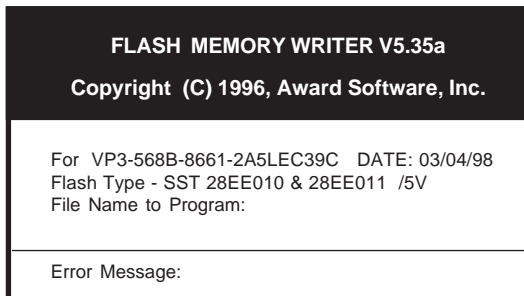

5. If you don't want to save the previous BIOS data to the diskette, please key in [N].

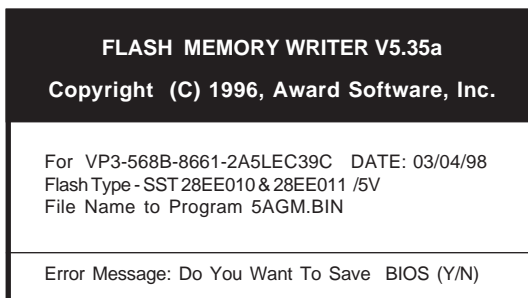

6. If you want to save the previous BIOS data to the diskette, please key in [Y].

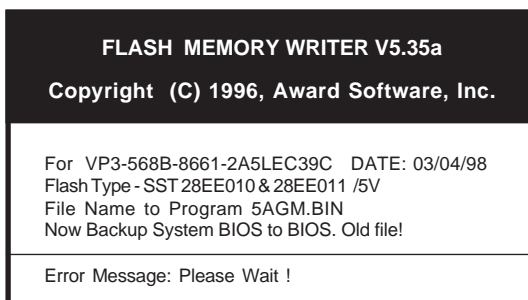

7. Type [Y], then you will start the programming.

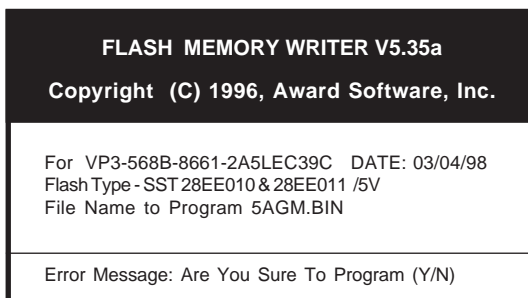

8. After the programming finishes, remove the floppy disk and reset the computer.

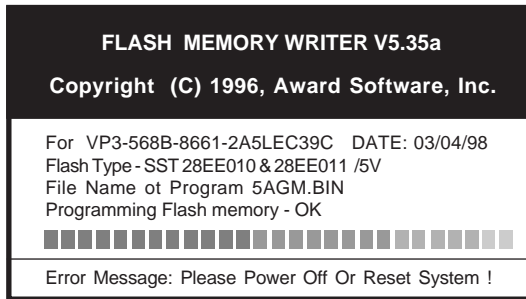

4-7 Award DMI Configuration Utility

DMI (Desktop Management Interface) is a new method of managing computers in an enterprise network. The main component of DMI is the MIFD (Management Information Format database). This database contains all the information about the computing system and its components. Using DMI, a system administrator can obtain the types, capabilities, operational status, installation data and other information about the system components.

We support DMI features in BIOS and provide a DMI utility to maintain a MIFD file.

The system BIOS uses the same technology implemented for plug and play to allow dynamic real-time update system information and store those collected information (e.g. CPU type and speed, Bus frequency, memory size and speed) block in the motherboard's Flash EPROM.

We also provide a friendly DMI utility (DMICFG.EXE) to allow the system integrator or end user to place necessary information in MIFD such as the serial number on the motherboard, add-on cards, monitor, etc. This information is not detected by the system BIOS and has to be manually input through the DMI utility.

The DMICFG.EXE(DMI Configuration Utility for modifying/reviewing the MIFD) contained in Drivers Disk that comes with your mainboard.



Please remove (or remark) any installed Memory Management Utility (such as EMM386.EXE, QEMM.EXE...,etc.) in the CONFIG.SYS files before running this utility.

Run DMICFG.EXE at D:\DMI\DMICFG and the following screen will prompt:

Award DMI Configuration Utility v1.08u, Copyright Award Software Inc. 1996	
[Edit DMI] [Add DMI] [Load DMI FILE] [Save DMI FILE]	
BIOS	== Display Component ===
System	
Base Board	
Enclosure/Chassis	Type : BIOS Information
Processor	Handle : 0000
Memory Controller	Vendor Name : Award software International, Inc.
Memory Module	BIOS Version : 4.51 PG
Memory Module	BIOS Starting Address Segment : E000
Memory Module	BIOS Build Date : 03/04/98
Memory Module	BIOS Characteristics : Press [Enter] for detail
Memory Module	Size of BIOS ROM : 0128K
Cache	
Cache	
Port Connector	
Port Connector	
Port Connector	
Port Connector	
Port Connector	
Port Connector	

↔ ↑↓ -Move cursor Enter-Accept DEL-Delete ESC-Abort&Exit

Use the ↔ (left-right) cursor to move the top menu items and the ↑↓ (up-down) cursor to move between the left hand menu items. The bottom of the screen will show the available keys for each screen. Press [Enter] at the menu item to enter the right hand screen for editing.

If you have made any changes, press [F10] to ensure the data keep in Flash ROM.



Memo

Appendix I

On Board I/O Addresses & IRQ Maps

System Resource	IRQ	I/O Address
1. Timer	IRQ0	040, 043
2. Keyboard	IRQ1	060, 064
3. Programmable INT	IRQ2	0020, 0021, 00A0, 00A1
4. COM2(B)	IRQ3	2F8, 2FF
5. COM1(A)	IRQ4	3F8, 3FF
6. Floppy	IRQ6	3F0, 3F7
7. LPT1	IRQ7	378, 37F
8. Real Time Clock	IRQ8	070, 071
9. PS/2 Mouse	IRQ12	060, 064
10.Math coprocessor	IRQ13	0F0, 0FF
11.IDE 1	IRQ14	1F0, 1F7
12.IDE 2	IRQ15	170, 177

🚫 IRQ 5, 9, 10 and 11 are available for interface cards.



Memo

Quick Connector and Jumper Reference

CN1: PS/2 mouse, USB, Infrared connector with optional USB kit

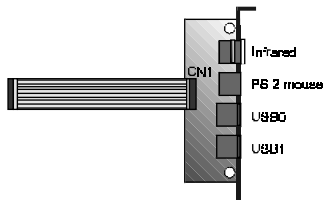
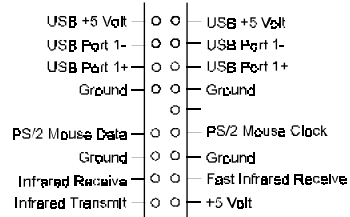

CN6: FAN78 connector

CN7: Front Panel connector set

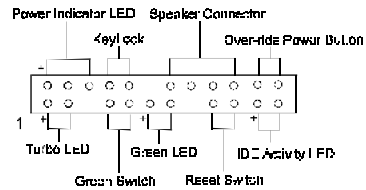

CPUFAN/SYSFAN: CPU/System cooling fan connector

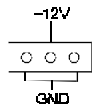

JP1: AT/ATX power supply jumper
 1~2: AT power
 2~3: ATX power

JP2: Clear CMOS data jumper
 1~2: Normal(default)
 2~3: Clear CMOS data

JP9: Reserved for factory

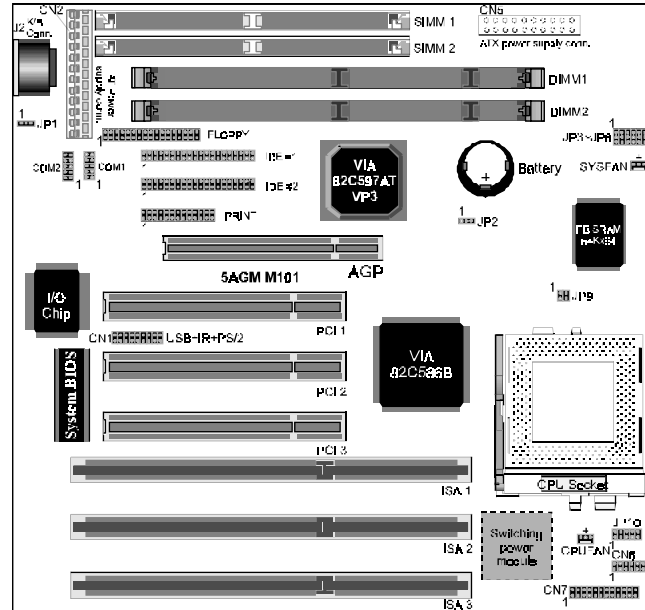

Vcore	JP10
2.2V	
2.8V	
2.9V	
3.2V	
3.3V	
3.5V	

System Freq.	JP3~JP5
50MHz	
55MHz	
60MHz	
66MHz	
75MHz	

Freq. Ratio	JP6~JP8
x 1.5	
x 2	
x 2.5	
x 3	
x 3.5	
x 4	

CPU-type		CPU Power Voltage		System freq.		Freq. ratio	
		I/O Vcc	Core Vcc	MHz	JP3~JP5	Speed rate	JP6~JP8
Intel	P54C-133	3.5	1	66	1	x2	
	P54C-166					x2.5	
	P54C-200					x3	
	Pentium w/MMX @166MHz	x2.5					
	Pentium w/MMX @200MHz	x3					
Pentium w/MMX @233MHz	3.3	2.8	x3.5				
Cyrus /IBM	6x86-PR166 @133MHz	3.5	1	66	1	x2	
	6x86-PR200 @150MHz			75	1		
	6x86L-PR166 @133MHz	2.8	1	66	1		
	6x86L-PR200 @150MHz			75	1		
	6x86MX-PR166	3.3	1	66	1		
	6x86MX-PR200			x2.5			
	6x86MX-PR200			75	1		
	6x86MX-PR233			x2.5			
AMD	K5-PR133 @100MHz	3.5	1	66	1	x2.5	
	K5-PR150 @105MHz			60	1		
	K5-PR166 @116.7MHz			66	1		
	K6/166	2.9	1	66	1	x2.5	
	K6/200					x3	
	K6/233	3.2	1			x3.5	
K6/266	2.2	1	x4				

Appendix II

FAN78-SMART Technology Upgrade Kit



FAN78



System Monitor Software for Win95

The FAN78 upgrade kit provides a PC self-diagnostic capability called the *SMART* (System Monitoring and Alerting) technology.

Features

- Detects four on-board voltages (CPU Core Voltage, 3.3V, 5V, 12V)
- Two fan speed sensing
- One precise CPU temperature sensor and one chassis temperature sensor
- Four types of speaker-driver signal output
- Supports system monitor software and drivers for **LDCM™** utility V3.1
- EISCA v1.0 compliant

FAN78 Connector

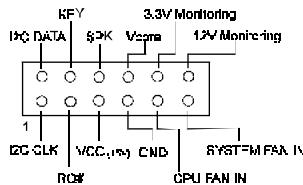



Memo