

BCM ADVANCED RESEARCH, INC.

IN530

Device Type	Mainboard
Processor	CX 6x86L/CX 6x86MX/CX MII/AM K5/AM K6/AM K6-2/AM K6-3/Pentium/Pentium MMX
Processor Speed	90/100/120/133/150/166/200/225/233/266/300/333/350/366/400/433/450MHz
Chip Set	SiS
Video Chip Set	SiS
Audio Chip Set	ESS
Maximum Onboard Memory	512MB (SDRAM supported)
Maximum Video Memory	Unidentified
Maximum Audio Memory	Unidentified
Cache	0/512KB
BIOS	AMI
Dimensions	244mm x 206mm
I/O Options	16-bit ISA slot, 32-bit PCI slots (3), ATX power connector, audio in - CD-ROM, auxiliary in, floppy drive interface, front USB interface, game/MIDI port, green PC connector, IDE interfaces (2), line in, line out, microphone in, modem connector, parallel port, PS/2 keyboard port, PS/2 mouse port, serial interface, serial port, USB ports (2), VGA port, Wake-on-LAN connector, Wake-on-modem connector

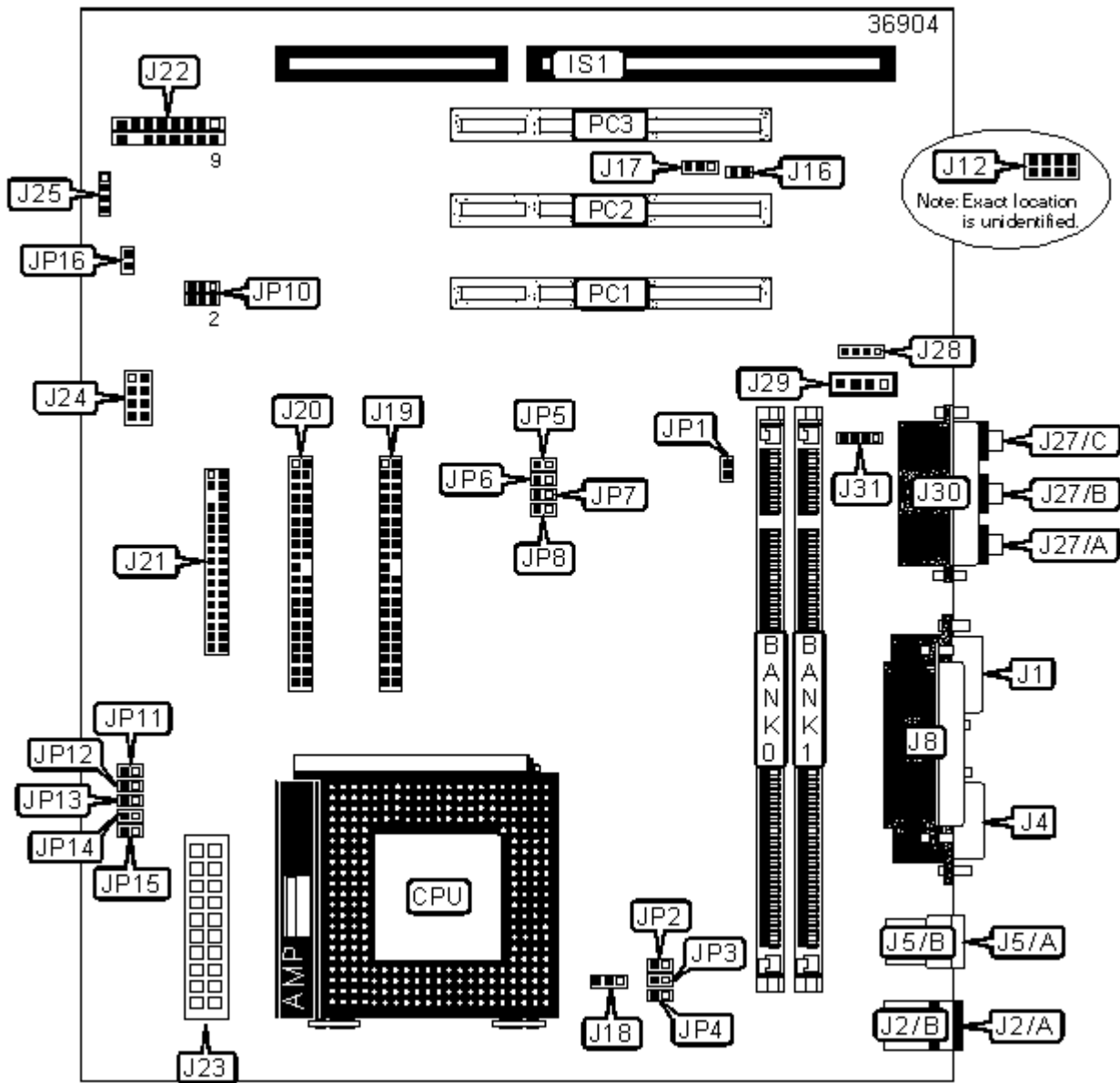

CONNECTIONS

Purpose	Location	Purpose	Location
VGA port	J1	Power/Green PC LED	J22/Pins 9 & 10
PS/2 keyboard port	J2/A	Power switch	J22/Pins 11 & 12
PS/2 mouse port	J2/B	Green PC switch	J22/Pins 13 & 14
Serial port 1	J4	ATX power connector	J23
USB port 1	J5/A	Front USB interface	J24
USB port 2	J5/B	Speaker (Reserved)	J25
Parallel port	J8	Line out	J27/A
Serial interface 2 (Reserved)	J12	Line in	J27/B
Wake-on-modem connector	J16	Microphone in	J27/C

Wake-on-LAN connector	J17	Auxiliary in	J28
CPU fan power	J18	Audio in - CD-ROM	J29
IDE interface 2	J19	Game/MIDI port	J30
IDE interface 1	J20	Modem connector	J31
Floppy drive interface	J21	16-bit ISA slot	IS1
IDE interface LED	J22/Pins 1 & 2	32-bit PCI slots	PC1 - PC3
Reset switch	J22/Pins 3 & 4		

USER CONFIGURABLE SETTINGS

Function		Label	Position
»	Onboard video enabled	JP1	Open
	Onboard video disabled	JP1	Closed
	Front USB interface selected	JP10	Pins 1 & 3, 2 & 4 closed
	Back panel USB ports selected	JP10	Pins 3 & 5, 4 & 6 closed
»	CMOS memory normal operation	JP16	Open
	CMOS memory clear	JP16	Closed

DIMM CONFIGURATION

Size	Bank 0	Bank 1
8MB	(1) 1M x 64	None
16MB	(1) 1M x 64	(1) 1M x 64
16MB	(1) 2M x 64	None
24MB	(1) 2M x 64	(1) 1M x 64
32MB	(1) 2M x 64	(1) 2M x 64
32MB	(1) 4M x 64	None
40MB	(1) 4M x 64	(1) 1M x 64
48MB	(1) 4M x 64	(1) 2M x 64
64MB	(1) 4M x 64	(1) 4M x 64
64MB	(1) 8M x 64	None

72MB	(1) 8M x 64	(1) 1M x 64
80MB	(1) 8M x 64	(1) 2M x 64
96MB	(1) 8M x 64	(1) 4M x 64
128MB	(1) 8M x 64	(1) 8M x 64
128MB	(1) 16M x 64	None
136MB	(1) 16M x 64	(1) 1M x 64
144MB	(1) 16M x 64	(1) 2M x 64
160MB	(1) 16M x 64	(1) 4M x 64
192MB	(1) 16M x 64	(1) 8M x 64
256MB	(1) 16M x 64	(1) 16M x 64
256MB	(1) 32M x 64	None
264MB	(1) 32M x 64	(1) 1M x 64
272MB	(1) 32M x 64	(1) 2M x 64
288MB	(1) 32M x 64	(1) 4M x 64
320MB	(1) 32M x 64	(1) 8M x 64
384MB	(1) 32M x 64	(1) 16M x 64
512MB	(1) 32M x 64	(1) 32M x 64

Note: Board supports SDRAM memory.

CPU EXTERNAL CLOCK SELECTION

Clock Speed	JP5	JP6	JP7	JP8
66MHz	Open	Closed	Closed	Closed
75MHz	Open	Closed	Closed	Open
83MHz	Open	Closed	Open	Closed
90MHz	Closed	Closed	Closed	Closed
95MHz	Open	Closed	Open	Open
100MHz	Open	Open	Closed	Closed

CPU MULTIPLIER SELECTION

Multiplier	JP2	JP3	JP4
1.5x	Open	Open	Open
2.0x	Closed	Open	Open
2.5x	Closed	Closed	Open
3.0x	Open	Closed	Open
3.5x	Open	Open	Open
4.0x	Closed	Open	Closed
4.5x	Closed	Closed	Closed
5.0x	Open	Closed	Closed
5.5x	Open	Open	Closed
6.0x	Closed	Open	Open

VCORE SELECTION					
Setting	JP11	JP12	JP13	JP14	JP15
1.8V	Open	Closed	Open	Closed	Closed
2.1V	Closed	Open	Open	Open	Open
2.2V	Open	Closed	Open	Open	Open
2.3V	Closed	Closed	Open	Open	Open
2.4V	Open	Open	Closed	Open	Open
2.8V	Open	Open	Open	Closed	Open
2.9V	Closed	Open	Open	Closed	Open
3.1V	Closed	Closed	Open	Closed	Open
3.2V	Open	Open	Closed	Closed	Open