

Dell® PowerEdge® 2200 Systems

USER'S GUIDE

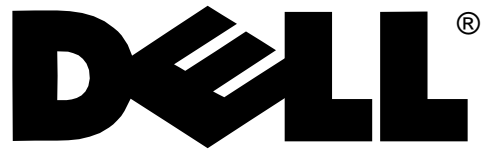

Information in this document is subject to change without notice.

© 1997 Dell Computer Corporation. All rights reserved.

Reproduction in any manner whatsoever without the written permission of Dell Computer Corporation is strictly forbidden.

Trademarks used in this text: *Dell*, the *DELL* logo, and *PowerEdge* are registered trademarks and *DellWare* is a registered service mark of Dell Computer Corporation; *Intel*, *Pentium*, and *LANdesk* are registered trademarks and *MMX*, *Intel386*, *Intel486*, *IntelDX2*, and *IntelDX4* are trademarks of Intel Corporation; *Microsoft*, *MS-DOS*, and *Windows NT* are registered trademarks of Microsoft Corporation; *Novell* and *NetWare* are registered trademarks of Novell, Inc.; *IBM* and *OS/2* are registered trademarks of International Business Machines Corporation; *ASPI* is a registered trademark of Adaptec, Inc.; *UNIX* is a registered trademark of UNIX System Laboratories, Inc., a wholly owned subsidiary of Novell, Inc.; *VESA* is a registered trademark and *VL-Bus* is a trademark of Video Electronics Standards Association; *Adobe* is a trademark of Adobe Systems Incorporated.

Other trademarks and trade names may be used in this document to refer to either the entities claiming the marks and names or their products. Dell Computer Corporation disclaims any proprietary interest in trademarks and trade names other than its own.

May 1997 P/N 87238

Safety Instructions

Use the following safety guidelines to help protect your computer system from potential damage and to ensure your own personal safety.

When Using Your Computer System

As you use your computer system, observe the following safety guidelines:

- To help avoid damaging your computer, be sure the voltage selection switch on the power supply is set to match the alternating current (AC) power available at your location:
 - 115 volts (V)/60 hertz (Hz) in most of North and South America and some Far Eastern countries such as Japan, South Korea, and Taiwan
 - 230 V/50 Hz in most of Europe, the Middle East, and the Far East
- Also be sure your monitor and attached peripherals are electrically rated to operate with the AC power available in your location.
- To help avoid possible damage to the system board, wait 5 seconds after turning off the system before removing a component from the system board or disconnecting a peripheral device from the computer.
- To help prevent electric shock, plug the computer and peripheral power cables into properly grounded power sources. These cables are equipped with 3-prong plugs to help ensure proper grounding. Do not use adapter plugs or remove the grounding prong from a cable. If you must use an extension cable, use a 3-wire cable with properly grounded plugs.
- To help protect your computer system from sudden, transient increases and decreases in electrical power, use a surge suppressor, line conditioner, or uninterruptible power supply.
- Be sure nothing rests on your computer system's cables and that the cables are not located where they can be stepped on or tripped over.
- Do not spill food or liquids on your computer. If the computer gets wet, consult your *Diagnostics and Troubleshooting Guide*.
- Do not push any objects into the openings of your computer. Doing so can cause fire or electric shock by shorting out interior components.
- Keep your computer away from radiators and heat sources. Also, do not block cooling vents. Avoid placing loose papers underneath your computer; do not place your computer in a closed-in wall unit or on a rug.

Ergonomic Computing Habits

WARNING: Improper or prolonged keyboard use may result in injury.

For comfort and efficiency, observe the following ergonomic guidelines when setting up and using your computer system:

- Position your system so that the monitor and keyboard are directly in front of you as you work. Special shelves are available (from Dell and other sources) to help you correctly position your keyboard.

- Set the monitor at a comfortable viewing distance (usually 510 to 610 millimeters [20 to 24 inches] from your eyes).
- Make sure the monitor screen is at eye level or slightly lower when you are sitting in front of the monitor.
- Adjust the tilt of the monitor, its contrast and brightness settings, and the lighting around you (such as overhead lights, desk lamps, and the curtains or blinds on nearby windows) to minimize reflections and glare on the monitor screen.
- Use a chair that provides good lower back support.
- Keep your forearms horizontal with your wrists in a neutral, comfortable position while using the keyboard or mouse.
- Always leave space to rest your hands while using the keyboard or mouse.
- Let your upper arms hang naturally at your sides.
- Sit erect, with your feet resting on the floor and your thighs level.
- When sitting, make sure the weight of your legs is on your feet and not on the front of your chair seat. Adjust your chair's height or use a footrest, if necessary, to maintain proper posture.
- Vary your work activities. Try to organize your work so that you do not have to type for extended periods of time. When you stop typing, try to do things that use both hands.

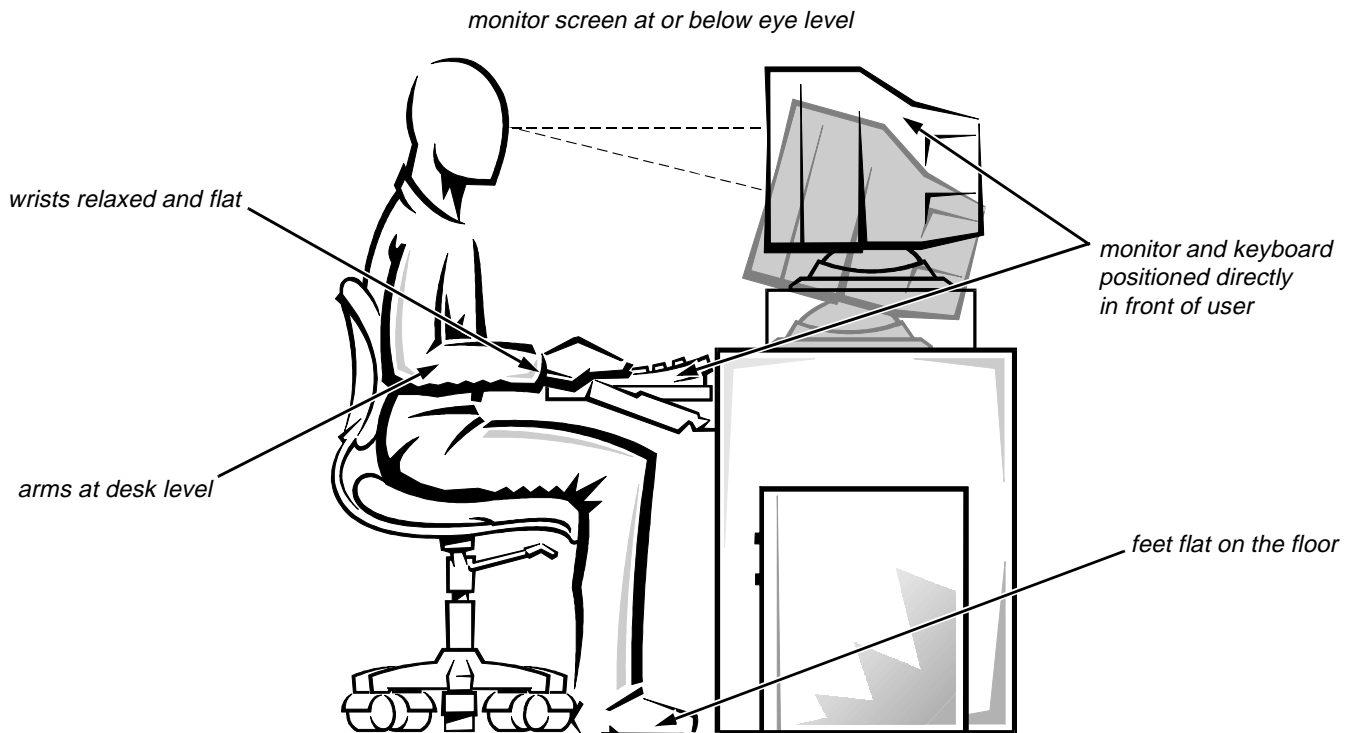

When Working Inside Your Computer

Before you remove the computer cover, perform the following steps in the sequence indicated.

CAUTIONS: Do not attempt to service the computer system yourself, except as explained in this guide and elsewhere in Dell documentation. Always follow installation and service instructions closely.

To help avoid possible damage to the system board, wait 5 seconds after turning off the system before removing a component from the system board or disconnecting a peripheral device from the computer.

1. **Turn off your computer and any peripherals.**
2. **Disconnect your computer and peripherals from their power sources. Also, disconnect any telephone or telecommunication lines from the computer.**
3. **Touch an unpainted metal surface on the chassis, such as the metal around the card-slot openings at the back of the computer, before touching anything inside your computer.**

Doing so reduces the potential for personal injury or shock.

While you work, periodically touch an unpainted metal surface on the computer chassis to dissipate any static electricity that might harm internal components.

In addition, take note of these safety guidelines when appropriate:

- When you disconnect a cable, pull on its connector or on its strain-relief loop, not on the cable itself. Some cables have a connector with locking tabs; if you are disconnecting this type of cable, press in on the locking tabs before disconnecting the cable. As you pull connectors apart, keep them evenly aligned to avoid bending any connector pins. Also, before you connect a cable, make sure both connectors are correctly oriented and aligned.

- Handle components and cards with care. Don't touch the components or contacts on a card. Hold a card by its edges or by its metal mounting bracket. Hold a component such as a microprocessor chip by its edges, not by its pins.

Protecting Against Electrostatic Discharge

Static electricity can harm delicate components inside your computer. To prevent static damage, discharge static electricity from your body before you touch any of your computer's electronic components, such as the microprocessor. You can do so by touching an unpainted metal surface on the computer chassis.

As you continue to work inside the computer, periodically touch an unpainted metal surface to remove any static charge your body may have accumulated.

In addition to the preceding precautions, you can also take the following steps to prevent damage from electrostatic discharge (ESD):

- When unpacking a static-sensitive component from its shipping carton, do not remove the component from the antistatic packing material until you are ready to install the component in your computer. Just before unwrapping the antistatic packaging, be sure to discharge static electricity from your body.
- When transporting a sensitive component, first place it in an antistatic container or packaging.
- Handle all sensitive components in a static-safe area. If possible, use antistatic floor pads and workbench pads.

The following caution may appear throughout this document to remind you of these precautions:

CAUTION: See "Protecting Against Electrostatic Discharge" in the safety instructions at the front of this guide.

Preface

About This Guide

This guide is intended for anyone who uses the Dell PowerEdge 2200 computer systems. The guide can be used by both first-time and experienced computer users who want to learn about the features and operation of the systems or who want to upgrade their computers. The chapters and appendixes are summarized as follows:

- Everyone should read Chapter 1, “Introduction,” for an overview of the system features, a description of the controls and indicators on the front panel, and a general discussion of connecting external devices to the back panel of the computer.
- Users who want to use the utilities, the diagnostics, the online documentation, or install drivers for their operating system should read Chapter 2, “Using the Dell Server Assistant CD.”
- Everyone should read the first few sections of Chapter 3, “Installing and Configuring SCSI Drivers,” to find out which small computer system interface (SCSI) device drivers (if any) are required for a particular system configuration. Users who need to install and configure particular SCSI device drivers should then read the appropriate section for their operating system.
- Everyone should read the first several sections of Chapter 4, “Using the System Setup Program,” to familiarize themselves with this important program. Only users who want to make configuration changes to their system or who want to use the password features need to read the rest of Chapter 4.
- Everyone should read Chapter 5, “Using the EISA Configuration Utility,” whenever an Extended Industry-Standard Architecture (EISA) or Industry-Standard Architecture (ISA) expansion card is added, removed, or repositioned in the computer.

Also, when you change the memory size or settings for one of the built-in devices, you must run this utility.

- Chapter 6, “Working Inside Your Computer,” Chapter 7, “Installing System Board Options,” Chapter 8, “Installing Drives in the External Bays,” and Chapter 9, “Installing Drives in the Internal Bays,” are intended for users who want to install or remove options inside the computer, such as dual in-line memory modules (DIMMs), expansion cards, or drives.
- Appendix A, “Technical Specifications,” and Appendix B, “Hardware Configuration Features,” are intended primarily as reference material for users interested in learning more about the details of the system. Users who add internal options may need to refer to Appendix B to change jumper settings.
- Appendix C, “Maintaining the System,” describes preventive maintenance procedures that you should perform regularly to keep your computer system in top operating condition.
- Appendix D, “Regulatory Notices,” is for users who are interested in which regulatory agencies have tested and approved the Dell PowerEdge 2200 systems.
- Appendix E, “Warranties and Return Policy,” describes the warranties for Dell PowerEdge 2200 systems and the “Total Satisfaction” Return Policy.
- Appendix F, “Beep Codes and System Messages,” describes the beep codes and system messages that the system can generate when problems occur. The information in this appendix replaces the information in Chapter 3, “Messages and Codes,” in the *Diagnostics and Troubleshooting Guide*.
- The Glossary provides definitions of terms, acronyms, and abbreviations used in this guide.

Warranty and Return Policy Information

Dell Computer Corporation (“Dell”) manufactures its hardware products from parts and components that are new or equivalent to new in accordance with industry-standard practices. For information about the Dell warranty for your system, see Appendix E, “Warranties and Return Policy.”

Other Documents You May Need

In addition to this *User’s Guide*, the following documentation is included with your system:

- The *Diagnostics and Troubleshooting Guide* includes troubleshooting procedures and instructions for using the diskette-based diagnostics to test your computer system.
- The Intel LANDesk Server Manager software includes a CD-ROM containing the server manager software, plus the following documents: *LANDesk Server Manager Setup Guide*, *LANDesk Server Manager User’s Guide*, *LANDesk Server Control Installation and User’s Guide*, *LANDesk Server Monitor Module Installation and User’s Guide*.

You may also have one or more of the following documents.

*NOTE: Documentation updates are sometimes included with your system to describe changes to your system or software. Always read these updates **before** consulting any other documentation because the updates often contain the latest information.*

- Operating system documentation is included if you ordered your operating system software from Dell. This documentation describes how to install (if necessary), configure, and use your operating system software.

- Documentation is included with any options you purchase separately from your system. This documentation includes information that you need to configure and install these options in your Dell computer. Installation instructions for the options are also included in this guide.
- Technical information files—sometimes called “readme” files—may be installed on your hard-disk drive to provide last-minute updates about technical changes to your system or advanced technical reference material intended for experienced users or technicians.

Notational Conventions

The following subsections list notational conventions used in this document.

Warnings, Cautions, and Notes

Throughout this guide, there may be blocks of text printed in bold type within boxes or in italic type. These blocks are warnings, cautions, and notes, and they are used as follows:

WARNING: A WARNING indicates the potential for bodily harm and tells you how to avoid the problem.

CAUTION: A CAUTION indicates either potential damage to hardware or loss of data and tells you how to avoid the problem.

NOTE: A NOTE indicates important information that helps you make better use of your computer system.

Typographical Conventions

The following list defines (where appropriate) and illustrates typographical conventions used as visual cues for specific elements of text throughout this document:

- *Keycaps*, the labeling that appears on the keys on a keyboard, are enclosed in angle brackets.
Example: <Enter>
- *Key combinations* are series of keys to be pressed simultaneously (unless otherwise indicated) to perform a single function.
Example: <Ctrl><Alt>
- *Commands* presented in lowercase bold are for reference purposes only and are not intended to be typed at that particular point in the discussion.
Example: “Use the **format** command to. . .”
In contrast, commands presented in the Courier New font are intended to be typed as part of an instruction.
Example: “Type `format a:` to format the diskette in drive A.”
- *Filenames* and *directory names* are presented in lowercase bold.
Example: **autoexec.bat** and **c:\windows**
- *Syntax lines* consist of a command and all its possible parameters. Commands are displayed in

lowercase bold; variable parameters (those for which you substitute a value) are displayed in lowercase italics; constant parameters are displayed in lowercase bold. The brackets indicate items that are optional.

Example: **del** [*drive:*] [*path*]*filename* [**/p**]

- *Command lines* consist of a command and may include one or more of the command’s possible parameters. Command lines are presented in the Courier New font.
Example: `del c:\myfile.doc`
- *Screen text* is text that appears on the screen of your monitor or display. It can be a system message, for example, or it can be text that you are instructed to type as part of a command (referred to as a *command line*). Screen text is presented in the Courier New font.
Example: The following message appears on your screen:
`No boot device available`
Example: “Type `md c:\dos`, and then press <Enter>.”
- *Variables* are symbols for which you substitute a value. They are presented in italics.
Example: DIMM*n* (where *n* represents the DIMM number)

Contents

Chapter 1

Introduction 1-1

System Features.	1-1
Supported Operating Systems	1-3
Front Panel	1-3
Connecting External Devices	1-3
Preventing Unauthorized Access Inside the Computer.	1-4
Getting Help	1-4

Chapter 2

Using the Dell Server Assistant CD 2-1

Booting the CD	2-1
CD Main Menu	2-1
Choose Language.	2-1
Configure the System.	2-1
Run System Utilities	2-1
Use Online Manuals.	2-1
Create Diskettes	2-2
Video Drivers	2-2
Installing Video Drivers for Windows NT 4.0.	2-2
Asset Tag Utility	2-2
Using the Asset Tag Utility	2-2
Assigning and Deleting an Asset Tag Number.	2-3

Chapter 3

Installing and Configuring SCSI Drivers 3-1

The readme.txt File	3-1
The SCSISelect Utility	3-1
SCSISelect Default Settings	3-1
Basic Host Adapter Settings	3-2

Boot Device Settings	3-2
SCSI Device Settings	3-3
Advanced Host Adapter Settings	3-3
Starting the SCSISelect Utility	3-4
Using SCSISelect Menus	3-5
Using the SCSI Disk Utilities	3-5
Exiting SCSISelect	3-5
Installation for Windows NT	3-5
Installation Overview	3-5
Installing Windows NT 4.0 and the Driver	3-6
Using Windows NT to Install or Update the Driver	3-6
Installing or Updating the Driver With Windows NT 4.0	3-6
Removing a Host Adapter	3-6
Swapping a Host Adapter	3-7
Troubleshooting for Windows NT	3-7
Installation for Novell NetWare	3-7
Installation Overview	3-8
Installing EZ-SCSI	3-8
Calculating the Slot Number	3-9
Installing NetWare and the Driver	3-9
Performing a NetWare 4.11 Installation	3-10
Using NetWare to Install or Update the Driver	3-10
Using the load Command Line Options	3-11
Bit Mask Options	3-12
Sample load Command	3-12
Using startup.ncf and autoexec.ncf	3-13
Using SCSI Devices	3-13
Booting From a SCSI Device	3-13
Formatting Media	3-14
Using Removable Media	3-14
Using NetWare-Tested and -Approved Drives	3-15
Using the NetWare Tape Backup Utility	3-15
Setting Up a CD-ROM Drive With NetWare 4.11	3-15
Optimizing Performance	3-16
Troubleshooting for NetWare	3-16
Nonhost Adapters	3-16
Host Adapters	3-16

Chapter 4

Using the System Setup Program 4-1

System Setup Screens	4-1
Entering the System Setup Program	4-3
Main Menu Categories	4-4
Time	4-4
Date	4-4
Diskette Drive A and Diskette Drive B	4-4
Fast Video BIOS	4-4
Memory Cache	4-4
Boot Sequence	4-4
Boot Options Submenu Categories	4-5
Num Lock	4-6
Speaker	4-6
Processor 1 and Processor 2	4-6
Level 2 Cache	4-6
Base Memory	4-6
Extended Memory	4-6
Video Memory	4-6
Service Tag	4-6
Asset Tag	4-6
Advanced Menu Categories	4-7
Serial Port 1	4-8
Serial Port 2	4-8
Parallel Port	4-8
Parallel Mode	4-8
Diskette Controller	4-8
Onboard SCSI	4-8
PCI Scan Sequence	4-8
Use MP Specification	4-8
PS/2 Mouse	4-8
Security Menu Categories	4-9
Supervisor Password Is	4-10
User Password Is	4-10
Set Supervisor Password	4-10
Set User Password	4-10
Password on Boot	4-10
Diskette Access	4-10

System Backup Reminder	4-10
Virus Check Reminder	4-11
Exit Menu Categories	4-11
Save Changes & Exit	4-12
Exit Without Saving Changes	4-12
Get Default Values	4-12
Load Previous Values	4-12
Save Changes	4-12
Using the Password Features	4-12
Using the Supervisor Password Feature	4-12
Assigning a Supervisor Password	4-12
Using Your Supervisor Password to Secure Your System	4-13
Operating With a Supervisor Password Enabled	4-13
Deleting or Changing an Existing Supervisor Password	4-13
Using the User Password Feature	4-13
Assigning a User Password	4-14
Using Your User Password to Secure Your System	4-14
Deleting or Changing an Existing User Password	4-15
Disabling a Forgotten Password	4-15
Password Options	4-16
Responding to Error Messages	4-17

Chapter 5

Using the EISA Configuration Utility 5-1

Configuring EISA, ISA, and PCI Expansion Cards	5-1
System Board Options	5-1
How to Run the EISA Configuration Utility	5-2
When to Run the EISA Configuration Utility	5-2
Making Selections in the EISA Configuration Utility	5-3
Using Online Instructions	5-3
Starting the EISA Configuration Utility	5-3
Main Menu	5-4
Learn About Configuring Your Computer	5-4
Configure Computer	5-4
Step 1: Important EISA Configuration Information	5-4
Step 2: Add or Remove Boards	5-5
Step 3: View or Edit Details	5-6
Step 4: Examine Switches or Print Report	5-10
Step 5: Save and Exit	5-10

- Set Date and Set Time 5-10
- Maintain System Configuration Diskette 5-10
- Exit From This Utility 5-10
- Advanced Menu 5-10
 - Lock/Unlock Boards 5-10
 - View Additional System Information Menu 5-11
 - Set Verification Mode Menu 5-11
 - Maintain SCI Files Menu 5-11
- Resolving Resource Conflicts 5-11
 - Removing a Card That Conflicts With the Card You Just Installed 5-12
- System Board Options Screen 5-12
 - ISA Cycle Wait Control 5-12
 - Fail-Safe Timer NMI 5-12
 - Bus-Master Timeout NMI 5-12
 - Software Generated NMI 5-12
- Modeling Mode 5-12
- Using the Password Features 5-13
 - How Password Security Works 5-13
 - Assigning or Changing a Supervisor Password 5-14
 - Deleting an Existing Supervisor Password 5-14
 - Assigning or Changing a User Password 5-15
 - Deleting an Existing User Password 5-15
 - Disabling a Forgotten Password 5-16

Chapter 6
Working Inside Your Computer 6-1

- Before You Begin 6-1
 - Safety First—For You and Your Computer 6-1
- System Orientation 6-2
- Removing the Computer Cover 6-2
- Replacing the Computer Cover 6-2
- Removing the Front Bezel 6-2
- Replacing the Front Bezel 6-3
- Unpacking Your Hardware Option 6-3
- Inside Your Computer 6-3
 - Removing and Replacing the System Board Assembly 6-6
 - Removing the System Board Assembly 6-6
 - Replacing the System Board Assembly 6-7

Chapter 7
Installing System Board Options 7-1

System Orientation 7-2
Expansion Cards 7-2
 Expansion Slots 7-3
 Installing an Expansion Card 7-3
 Removing an Expansion Card 7-4
Adding Memory 7-5
 Memory Upgrade Kits 7-5
 DIMM Installation Guidelines 7-5
 Performing a Memory Upgrade 7-6
 Installing a DIMM 7-7
 Removing a DIMM 7-8
Installing a Microprocessor 7-8
Replacing the System Battery 7-10

Chapter 8
Installing Drives in the External Bays 8-1

Configuring a Drive 8-1
 Jumpers 8-1
Before You Begin 8-2
Removing and Replacing Front-Panel Inserts 8-2
 Removing and Replacing Plastic Inserts 8-2
 Removing Metal Inserts 8-3
Connecting the Drive 8-3
 DC Power Cables 8-4
Installing Drives in the External Bays 8-4
 Installing Diskette Drives That Use the Diskette Drive Controller 8-5
 Installing SCSI Drives in the External Bays 8-6
 Installing an Optional SCSI Controller for the External Bay SCSI Drives 8-7

Chapter 9
Installing Drives in the Internal Bays 9-1

SCSI Configuration Guidelines 9-1
 SCSI ID Numbers 9-1
 Device Termination 9-2
 Configuring the Boot Device 9-3
 SCSI Cable 9-3
Installing SCSI Hard-Disk Drives in the Internal Bays 9-5

Appendix A
Technical Specifications A-1

Appendix B
Hardware Configuration Features B-1

Jumpers B-1
Connectors and Sockets B-4
I/O Ports and Connectors B-5
 Serial and Parallel Ports B-5
 Adding an Expansion Card Containing Serial or Parallel Ports B-6
 Serial Port Connectors B-6
 Parallel Port Connector B-7
 Keyboard and Mouse Connectors B-7
 Keyboard Connector B-8
 Mouse Connector B-8
 Video Connector B-8

Appendix C
Maintaining the System C-1

Data Preservation C-1
 Scheduling Backups C-1
 Backup Devices C-1
 Recovering Data C-1
Cleaning System Components C-2
 Recommended Tools and Accessories C-2
 Cleaning the Computer, Monitor, and Keyboard Exteriors C-2
 Cleaning Drives C-3
Environmental Factors C-3
 Temperature C-3
 Humidity C-3
 Altitude C-4
 Dust and Particles C-4
 Corrosion C-4
 ESD C-4
 Electromagnetic and Radio Frequency Interference C-4
 Magnetism C-5
 Shock and Vibration C-5
 Power Source Interruptions C-5

Power Protection Devices	C-6
Surge Protectors	C-6
Line Conditioners	C-6
Uninterruptible Power Supply	C-6

Appendix D

Regulatory Notices D-1

FCC Notices (U.S. Only)	D-1
Class A	D-1
Class B	D-1
IC Notice (Canada Only)	D-2
EN 55022 Compliance (Czech Republic Only)	D-2
CE Notice	D-2
VCCI Notices (Japan Only)	D-3
Class 1 Notice	D-3
Class 2 Notice	D-3
Korean Regulatory Notice	D-4
Class A Device	D-4
Class B Device	D-4
Polish Center for Testing and Certification Notice	D-4
Wymagania Polskiego Centrum Badań i Certyfikacji	D-4
Pozostałe instrukcje bezpieczeństwa	D-4
NOM 024 Information (Mexico Only)	D-5
Información para Nom 024 (únicamente para México)	D-5

Appendix E

Warranties and Return Policy E-1

Limited Three-Year Warranty (U.S. Only)	E-1
Coverage During Year One	E-1
Coverage During Years Two and Three	E-2
General	E-2
Limited Three-Year Warranty (Canada Only)	E-2
Coverage During Year One	E-3
Coverage During Years Two and Three	E-3
General	E-3
“Total Satisfaction” Return Policy (U.S. and Canada Only)	E-4

Appendix F

Beep Codes and System Messages F-1

System Error Messages	F-1
System Beep Codes	F-5
Starting the System Diagnostics	F-6

Glossary

Index

Figures

Figure 1-1.	Front Panel	1-3
Figure 1-2.	Security Keylock.	1-4
Figure 3-1.	Bit Position	3-12
Figure 4-1.	Main Menu of the System Setup Program	4-3
Figure 4-2.	Boot Options Submenu	4-5
Figure 4-3.	Advanced Menu of the System Setup Program	4-7
Figure 4-4.	Security Menu of the System Setup Program	4-9
Figure 4-5.	Exit Menu of the System Setup Program	4-11
Figure 5-1.	EISA System Board Options Screen (Example).	5-9
Figure 6-1.	Removing the Computer Cover	6-2
Figure 6-2.	Removing the Front Bezel	6-3
Figure 6-3.	Inside the Chassis—Front/Right Side View	6-4
Figure 6-4.	Inside the Chassis—Back/Left Side View	6-5
Figure 6-5.	Removing the System Board Assembly	6-6
Figure 6-6.	Replacing the System Board Assembly	6-7
Figure 7-1.	System Board Features	7-1
Figure 7-2.	Expansion-Card Examples	7-2
Figure 7-3.	Removing the Filler Bracket.	7-3
Figure 7-4.	Installing an Expansion Card	7-4
Figure 7-5.	DIMMs and DIMM Sockets	7-5
Figure 7-6.	Installing a DIMM	7-7
Figure 7-7.	Removing a DIMM.	7-8
Figure 7-8.	Terminator Card	7-9
Figure 7-9.	Microprocessor Module Retention Screws.	7-9
Figure 7-10.	Installing a Microprocessor Module	7-9
Figure 7-11.	System Battery and Battery Socket	7-10
Figure 8-1.	External Drive Bay Hardware.	8-2

Figure 8-2.	Removing a Plastic Insert	8-3
Figure 8-3.	Removing a Metal Insert	8-3
Figure 8-4.	Power Connectors	8-4
Figure 8-5.	Interface Connectors	8-4
Figure 8-6.	DC Power Cable Connectors	8-4
Figure 8-7.	Drives in the External Bays	8-5
Figure 8-8.	Diskette Drive Interface Cable.	8-5
Figure 8-9.	Attaching Drive Rails	8-5
Figure 8-10.	68-Pin to 50-Pin Adapter	8-7
Figure 8-11.	Connecting an Optional SCSI Controller Card	8-8
Figure 9-1.	SCSI Termination Jumper Locations.	9-2
Figure 9-2.	SCSI Interface Cable	9-3
Figure 9-3.	SCSI Cable for a PowerEdge 2200 System	9-4
Figure 9-4.	Removing the Hard-Disk Drive Cage	9-5
Figure 9-5.	Installing a Hard-Disk Drive in the Drive Cage	9-6
Figure B-1.	System Board Jumpers.	B-2
Figure B-2.	I/O Ports and Connectors.	B-5
Figure B-3.	Pin Numbers for the Serial Port Connectors	B-6
Figure B-4.	Pin Numbers for the Parallel Port Connector	B-7
Figure B-5.	Pin Numbers for the Keyboard Connector.	B-8
Figure B-6.	Pin Numbers for the Mouse Connector	B-8
Figure B-7.	Pin Numbers for the Video Connector.	B-9

Tables

Table 2-1.	Asset Tag Command-Line Options	2-3
Table 3-1.	Default SCSI Controller Settings.	3-2
Table 3-2.	load Command Line Options.	3-11
Table 3-3.	Files Necessary to Boot From a SCSI Device	3-13
Table 3-4.	Drive Status Items	3-14
Table 3-5.	Read After Write Verify Settings	3-15
Table 4-1.	System Setup Keys	4-2
Table 4-2.	Password Options.	4-16
Table 7-1.	Sample DIMM Configurations	7-6
Table A-1.	Technical Specifications	A-1
Table B-1.	System Board Jumpers.	B-3
Table B-2.	Connectors and Sockets on the System Board.	B-4
Table B-3.	Pin Assignments for the Serial Port Connectors	B-7
Table B-4.	Pin Assignments for the Parallel Port Connector	B-7

Table B-5.	Pin Assignments for the Keyboard Connector	B-8
Table B-6.	Pin Assignments for the Mouse Connector	B-8
Table B-7.	Pin Assignments for the Video Connector	B-9
Table F-1.	System Error Messages	F-1
Table F-2.	System Beep Codes	F-5

Chapter 1

Introduction

Dell® PowerEdge® 2200 systems are high-speed, upgradable server systems designed around the Intel® Pentium® II family of microprocessors with MMX™ technology. The PowerEdge 2200 systems provide both Extended Industry-Standard Architecture (EISA) and high-performance Peripheral Component Interconnect (PCI) expansion slots to allow for future expansion of your system.

This chapter describes the major hardware and software features of the computer, provides information about the indicators and controls on the computer's front panel, and discusses connecting external devices to the computer.

System Features

The PowerEdge 2200 systems offer the following major features:

- One or two Pentium II microprocessors with an internal operating frequency of 233 or 266 megahertz (MHz) and an external bus speed of 66 MHz.

The Pentium II microprocessor includes MMX technology designed to handle complex multimedia and communications software. This microprocessor incorporates new instructions and data types as well as a technique called Single Instruction, Multiple Data (SIMD) that allows the microprocessor to process multiple data elements in parallel, thereby improving overall system performance.

- A secondary (L2) cache of 512 kilobytes (KB) of static random-access memory (SRAM) is included within the single-edge contact (SEC) cartridge that contains the microprocessor. Math coprocessor functionality is internal to the microprocessor.

- Support for symmetric multiprocessing is available by installing a second Pentium II microprocessor. Symmetric multiprocessing greatly improves overall system performance by dividing microprocessor operations between the two independent microprocessors. To take advantage of this feature, you must use an operating system that supports multiprocessing, such as Microsoft® Windows NT® 4.0 or Novell® NetWare® 4.11 (and later versions).

NOTE: If you decide to upgrade your system by installing a second microprocessor, you must order a microprocessor upgrade kit from Dell. Not all versions of the Pentium II microprocessor will work properly as a second microprocessor. The upgrade kit from Dell contains the correct version of the microprocessor chip for use as a second microprocessor, as well as instructions for performing the upgrade. The second microprocessor must have the same internal operating frequency as the first.

- A minimum of 32 megabytes (MB) of system memory, upgradable to a maximum of 512 MB by installing combinations of 32- and 128-MB buffered, extended-data output (EDO), dual in-line memory modules (DIMMs) in the four DIMM sockets on the system board.

The buffered 72-bit-wide EDO DIMMs installed in PowerEdge 2200 systems support error correction code (ECC) to check for and correct memory errors. ECC is performed by the memory controller in the system chip set.

- A basic input/output system (BIOS) that resides in flash memory on the EISA bus and can be upgraded by diskette if required.

The system board includes the following built-in features:

- Three EISA and three PCI expansion-card connectors, located on the system board. A separate expansion-card slot is available for each EISA and PCI expansion-card connector; there are no shared expansion slots.
- An integrated video graphics array (VGA)-compatible video subsystem with an ATI mach64 (264VT) PCI video controller connected to the PCI local bus. The standard video subsystem includes 1 MB of video memory. Maximum resolutions (noninterlaced) are 640 x 480 pixels (16.7 million colors), 800 x 600 pixels (65,536 colors), and 1024 x 768 pixels (256 colors).
- An integrated National Semiconductor PC87336 super input/output (I/O) controller that controls the bidirectional parallel port, two serial ports, and the diskette drive in the externally accessible front bay. The super I/O controller resides on the EISA bus.

The parallel port can be set to operate in the following modes via the Parallel Mode category in the System Setup program: output-only (AT-compatible), bidirectional (Personal System/2 [PS/2]-compatible), or extended capabilities port (ECP).
- An integrated Adaptec AIC-7880 Ultra/Wide (fast-20) small computer system interface (SCSI) controller. The built-in SCSI controller supports up to two externally accessible SCSI devices in the external bays and up to three SCSI hard-disk drives in the internal bays. The SCSI interface connects to supported devices via a 68-conductor cable. The integrated SCSI controller resides on the PCI local bus for optimum performance.
- Integrated server management circuitry that monitors operation of the system fan as well as critical system voltages and temperatures. The integrated server management circuitry works in conjunction with the Intel LANdesk[®] Server Manager software. See the Preface for a list of documents that describe installation and use of the LANdesk Server Manager software.

- Integrated system board support for the Dell Remote Assistant Card, which provides improved local and remote server management.
- A PS/2-style keyboard port and a PS/2-compatible mouse port.

Standard PowerEdge 2200 systems include a diskette drive and a SCSI CD-ROM drive installed in the externally accessible bays and a SCSI hard-disk drive installed in one of the internal bays.

The following software is included with your Dell computer system:

- Video drivers for displaying many popular application programs in high-resolution modes. For more information on these drivers, see Chapter 2, “Using the Dell Server Assistant CD.”
- SCSI device drivers that allow your operating system to communicate with devices attached to the built-in SCSI subsystem. For more information on these drivers, see Chapter 3, “Installing and Configuring SCSI Drivers.”
- The System Setup program for quickly viewing and changing the system configuration information for your computer. For more information on this program, see Chapter 4, “Using the System Setup Program.”
- The EISA Configuration Utility, which allows you to configure installed EISA expansion cards through software rather than by hand. (You must also run the EISA Configuration Utility when installing or removing Industry-Standard Architecture [ISA] cards.) For more information, see Chapter 5, “Using the EISA Configuration Utility.”
- Enhanced security features available through either the System Setup program or the EISA Configuration Utility include a user password and a supervisor password.
- Diagnostics for evaluating your computer’s components and devices. For information on using the diskette-based diagnostics, see Chapter 2, “Using the Dell Server Assistant CD,” or see the chapter titled “Running the Diskette-Based Diagnostics” in your *Diagnostics and Troubleshooting Guide*.

Supported Operating Systems

Dell supports the following network operating systems for use on PowerEdge 2200 systems:

- Windows NT Server 4.0
- NetWare 4.11

Operating system software is not included with PowerEdge 2200 systems. If you purchase the operating system software from Dell, installation instructions are included on the CD-ROM that contains the operating system software.

NOTE: Installation services and support for other operating systems are available through Dell Plus. For more information, see the chapter titled “Getting Help” in your Diagnostics and Troubleshooting Guide.

Front Panel

The following controls and indicators are located on the computer’s front panel (see Figure 1-1):

- The *power button* on the front panel controls the alternating current (AC) input power to the system’s power supply.
- The green *power indicator* in the center of the power button lights when the power supply is turned on and the system is receiving direct current (DC) power.
- When any SCSI device is being accessed, the *drive access indicator* on the front panel lights.
- The *reset button* on the front panel saves wear and tear on system components by allowing you to reboot (restart) the computer without turning the power off and then on again. For more information about using the reset button, see “Reset Button” in Chapter 4.

NOTE: The power button and the reset button are recessed into the computer’s front panel to prevent accidentally turning off or resetting the computer and losing valuable data.

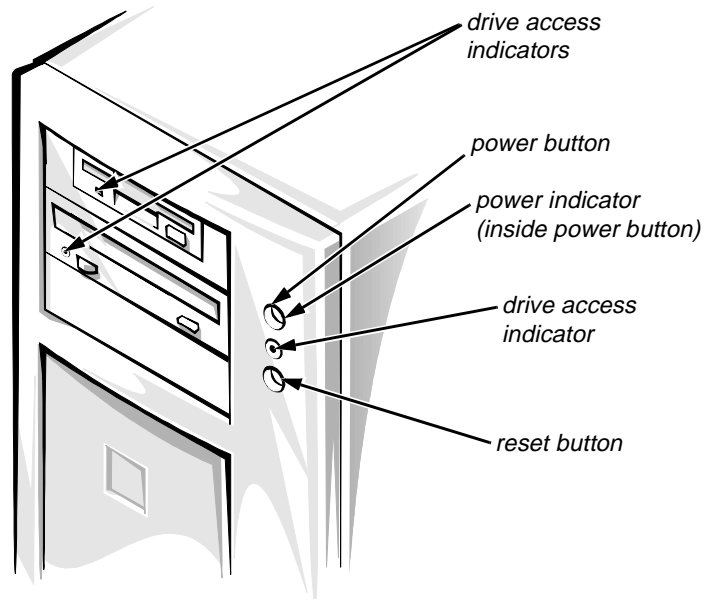

Figure 1-1. Front Panel

Connecting External Devices

You can connect various external devices, such as a mouse and printer, to the I/O ports and connectors on the computer’s back panel. The system BIOS detects the presence of external devices when you boot or reboot your system. When connecting external devices to your computer, follow these guidelines:

- Check the documentation that accompanied the device for specific installation and configuration instructions.

For example, most devices must be connected to a particular I/O port or connector to operate properly. Also, external devices like a mouse or printer usually require you to load software files called *device drivers* into memory before they will work. These software drivers help the computer recognize an external device and direct its operation. Device drivers of this type are normally included with your operating system software.
- Always attach external devices *while your computer is turned off*. Then turn on any external devices *before* turning on the computer unless the documentation for the device specifies otherwise. (If the computer does not seem to recognize the device, try turning on the computer before turning on the device.)

For information about enabling, disabling, or configuring I/O ports and connectors, see Chapter 4, “Using the System Setup Program,” or Chapter 5, “Using the EISA Configuration Utility.” For detailed descriptions and illustrations of each port and connector on the I/O panel, see “I/O Ports and Connectors” in Appendix B.

***P*reventing Unauthorized Access Inside the Computer**

To prevent unauthorized access to the inside of the computer, you can replace one of the screws that secure the cover to the chassis with a special keylock screw that is included with the system. A key, provided with the system, is required to install or remove the special keylock screw, thus preventing anyone without access to the tool from removing the computer cover (see Figure 1-2).

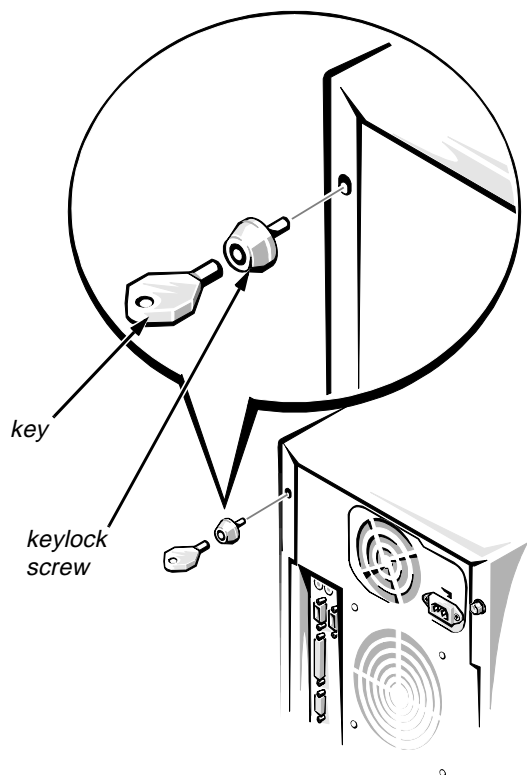

Figure 1-2. Security Keylock

***G*etting Help**

If at any time you don't understand a procedure described in this guide, or if your system does not perform as expected, Dell provides a number of tools to help you. For more information on these help tools, see the chapter titled “Getting Help” in your *Diagnostics and Troubleshooting Guide*.

Chapter 2

Using the Dell Server Assistant CD

This chapter describes the bootable *Dell Server Assistant* CD and tells you how to use the utilities, diagnostics, documentation, drivers, and other items included on the CD. This chapter also describes how to install the video drivers for supported operating systems and how to use the asset tag utility provided on the CD.

Booting the CD

Start the system before inserting the CD. To boot the CD, insert it into the PowerEdge 2200 system's CD-ROM drive and press the reset button, after ensuring that any operating system has been shut down. When the system boots, the CD main menu appears.

If the CD does not boot, check the following:

- In the System Setup program, the Onboard SCSI category must be set to Enabled, the Diskette Controller category must be set to Enabled, and the Boot Sequence category must be set to A: then C: (see Chapter 4, "Using the System Setup Program").
- In the SCSI*Select* Utility, the BIOS Support for Bootable CD-ROM category must be set to Enabled (see Chapter 3, "Installing and Configuring SCSI Drivers").

CD Main Menu

The main menu of the CD can include various options, depending on your system configuration. The following list shows some of the possible categories; the main menu on your CD may contain additional options. The subsections that follow describe possible choices within each menu item:

- Choose Language

- Configure the System
- Run System Utilities
- Use Online Manuals
- Create Diskettes

Choose Language

When the system boots, you are given the option of choosing a language for the menus, help screens, messages, and online documentation. After you choose a language, the main menu appears in the chosen language.

Configure the System

You can use the options within the Configure the System category for such tasks as running the EISA Configuration Utility from the CD or a diskette, or for configuring a redundant array of inexpensive disks (RAID) subsystem (if applicable).

Run System Utilities

The options within the Run System Utilities category allow you to run the system diagnostics and any other utilities available on your CD.

Use Online Manuals

The Use Online Manuals category includes all available online manuals. Selecting one of the online manuals launches the Adobe™ Acrobat viewer (included on the CD) and allows you to view or print the online manual in the language that you selected earlier.

NOTE: You can also copy the **portable document format (PDF)** files from the CD and use them under your native operating system.

Create Diskettes

The Create Diskettes category allows you to create diskettes of system utilities and operating system-specific drivers as well as blank formatted diskettes.

Video Drivers

You will need to install the video drivers for the operating system you install on your PowerEdge 2200 system, unless they were installed by Dell. Use the following procedure to install the video drivers for the Windows NT operating system. NetWare provides a textual interface and does not require video drivers.

Installing Video Drivers for Windows NT 4.0

Select the Create Diskettes category from the Dell Server Assistant CD Main Menu, and create a diskette of software drivers for the Windows NT 4.0 operating system. After you make the diskette of drivers, use the following procedure to install the video drivers:

1. **Insert the diskette of drivers into the diskette drive on your system.**
2. **Run the Windows NT Display program located in the Control Panel in the Main group.**
3. **Select Change Display Type.**
4. **Select Change from the display options; then select Other.**
5. **When prompted for the correct path, type a : \ATI and press <Enter>.**

If the diskette is not in drive A, change the drive letter designation as appropriate.

After the system reads the diskette, it displays the ATI Graphics Accelerators option.

6. **Select the ATI Graphics Accelerators option; then click Install.**

Confirm your choice when prompted to do so, and all appropriate files will be copied to the hard-disk drive.

7. Restart Windows NT.

The system will start up using the ATI mach64 drivers in 640 x 480 mode and display an application that allows you to choose a resolution.

The maximum resolutions supported by the built-in ATI mach 64 video controller with 1 MB of video memory are 640 x 480 pixels (16.7 million colors) and 800 x 600 pixels (65,536 colors) (non-interlaced); and 1024 x 768 pixels (256 colors) (noninterlaced).

NOTE: If you select a resolution that is not supported by the ATI mach64 (264VT) video controller with 1 MB of memory, the operating system will substitute 640 x 480 in 256 colors.

Asset Tag Utility

The Asset Tag utility allows you to enter an asset tag number for your computer. The default System Setup screen (see Figure 4-1, for example) does not show the asset tag number unless you enter one using this utility.

NOTE: The Asset Tag utility works only on systems running MS-DOS®.

Using the Asset Tag Utility

Use the following procedure to create a system utility diskette and boot the system:

1. **If you have not already done so, create a bootable system utility diskette from the CD.**
2. **Insert the diskette in drive A, and reboot the system.**

After you boot the system with the system utility diskette, you can use the Asset Tag utility to enter an asset tag number that you or your organization assign to the computer. You can also use the Asset Tag utility to reenter the computer's service tag number if that becomes necessary.

You can view the asset tag number using the System Setup program as described in Chapter 4, "Using the System Setup Program."

Assigning and Deleting an Asset Tag Number

An asset tag number can have up to ten characters; any combination of characters, excluding spaces, is valid. To assign or change an asset tag number, type `asset` and a space followed by the new number; then press <Enter>. For example, type the following command line and press <Enter>:

```
asset 1234567890
```

When prompted to verify the asset tag number, type `y` and press <Enter>. The system then displays the new or modified asset tag number and the service tag number.

To delete the asset tag number without assigning a new one, type `asset /d` and press <Enter>.

Table 2-1 lists the command line options you can use with the Asset Tag utility. To use one of these options, type `asset` and a space followed by the option.

Table 2-1. Asset Tag Command-Line Options

Asset Tag Option	Description
<code>/d</code>	Deletes the asset tag number
<code>/?</code>	Displays the Asset Tag utility help screen

Chapter 3

Installing and Configuring SCSI Drivers

This chapter describes how to install and configure the Dell small computer system interface (SCSI) device drivers included with your Dell PowerEdge 2200 computer system. These device drivers are designed to work with the Adaptec AIC-7880 Ultra/Wide SCSI controller chip on the system board.

Both the built-in AIC-7880 host adapter and the optional AHA-2940UW SCSI controller card are all part of the Adaptec 78xx series of SCSI controllers, and use the 78xx series of SCSI drivers Dell provides. The Adaptec SCSI basic input/output system (BIOS), which is stored in your computer system's flash memory or on the optional AHA-2940UW SCSI controller card, links these SCSI device drivers to the built-in AIC-7880 host adapter or the optional AHA-2940UW SCSI controller card.

For instructions on installing SCSI hardware devices such as hard-disk drives, tape drives, or CD-ROM drives, see Chapter 8, "Installing Drives in the External Bays," and Chapter 9, "Installing Drives in the Internal Bays." For information on SCSI configuration guidelines (SCSI identification [ID] numbers and termination requirements), see "SCSI Configuration Guidelines" in Chapter 9.

After the SCSI devices you plan to use are installed, you may need to install and configure one or more SCSI device drivers so that your SCSI devices can communicate with your operating system.

SCSI device drivers are provided for the following operating systems:

- Microsoft Windows NT Server 4.0
- Novell NetWare 4.11

See Chapter 2, "Using the Dell Server Assistant CD," for instructions on creating a diskette of drivers for your operating system. For instructions on configuring the SCSI device drivers, see the appropriate sections in this chapter.

The readme.txt File

The **readme.txt** file that is included with your SCSI device drivers (in the `\pe2200\scsi` directory on the CD) provides updates to the information in this chapter.

Use the editor included with your operating system to view or print the **readme.txt** file or any other readme file.

The SCSISelect Utility

The BIOS for the built-in Adaptec AIC-7880 controller includes the menu-driven *SCSISelect* configuration utility, which allows you to change SCSI controller settings without opening the computer. *SCSISelect* also contains SCSI disk utilities that let you low-level format or verify the disk media of your SCSI hard-disk drives.

SCSISelect Default Settings

Default settings for the optional Adaptec AHA-2940UW SCSI controller and the built-in AIC-7880 SCSI controller are shown in Table 3-1. These default settings are appropriate for most Peripheral Component Interconnect (PCI) systems. Run *SCSISelect* only if you need to change any of the default settings.

*NOTE: The term **host adapter** is used throughout this chapter to refer to the built-in AIC-7880 SCSI controller or the optional AHA-2940UW SCSI controller card.*

For situations in which you might want or need to change the settings, see the descriptions of each setting in the following subsections. To change any of the default settings or to format or verify a disk, see "Starting the *SCSISelect* Utility" found later in this chapter.

Table 3-1. Default SCSI Controller Settings

Setting	Default
SCSI Bus Interface Definitions:	
Host Adapter SCSI ID	7
SCSI Parity Checking	Enabled
Host Adapter SCSI Termination	Low On/High On
Boot Device Options:	
Boot Target ID	0
Boot LUN Number	0
SCSI Device/Configuration:	
Initiate Sync Negotiation	Yes (Enabled)
Maximum Sync Transfer Rate	40 Mb/sec
Enable Disconnection	Yes (Enabled)
Initiate Wide Negotiation	Yes (Enabled)
Send Start Unit Command	Yes (Enabled)
Advanced Host Adapter:	
Host Adapter BIOS	Enabled
Support Removable Disks Under BIOS as Fixed Disks	Boot Only
Extended BIOS Translation for DOS Drivers > 1 GB	Enabled
Display <Ctrl><a> Message During BIOS Initialization	Enabled
Multiple LUN Support	Disabled
BIOS Support for Bootable CD-ROM	Enabled
BIOS Support for INT 13 Extensions	Enabled
Support for Ultra SCSI Speed	Enabled

NOTE: For the full name of an abbreviation or acronym used in this table, see the Glossary.

Basic Host Adapter Settings

The basic host adapter settings are the *SCSISelect* settings most likely to require modification.

- **Host Adapter SCSI ID.** This option sets the host adapter's SCSI ID. The default setting is SCSI ID 7, which allows the host adapter to support narrow SCSI devices in addition to wide SCSI devices. Dell recommends that you leave the host adapter set to SCSI ID 7.
- **SCSI Parity Checking.** This option determines whether the host adapter verifies the accuracy of data transfer on the SCSI bus. The default setting is Enabled. You should disable SCSI Parity Checking if any SCSI device connected to the host adapter does not support SCSI parity; otherwise, leave it enabled. Most SCSI devices support SCSI parity. If you are unsure if a device supports SCSI parity, consult the documentation for the device.
- **Host Adapter SCSI Termination.** This option sets termination on the host adapter. The default setting for all Adaptec 78xx series host adapters is Low On/High On. Dell recommends that you leave this option set to the default.

Boot Device Settings

The boot device settings allow you to specify the device from which to boot your computer.

- **Boot Target ID.** This option specifies the SCSI ID of the device from which you wish to boot your system. The default setting is SCSI ID 0. The SCSI ID selected here must correspond to the ID configured on the boot device.
- **Boot LUN Number.** If your boot device has multiple logical unit numbers (LUNs) and Multiple LUN Support is enabled (see "Advanced Host Adapter Settings" found later in this section), this option allows you to specify a particular LUN from which to boot on your boot device. The default setting is LUN 0.

SCSI Device Settings

The SCSI device settings allow you to configure certain parameters for each device on the SCSI bus. To configure a specific device, you must know the SCSI ID assigned to that device. If you are not sure of the SCSI ID, see “Using the SCSI Disk Utilities” found later in this section.

- **Initiate Sync Negotiation.** This option determines whether the host adapter initiates synchronous data transfer negotiation (*sync negotiation*) between itself and the device. The default setting is Yes.

The host adapter always responds to sync negotiation if the SCSI device initiates it. If neither the host adapter nor the SCSI device initiates sync negotiation, data is transferred asynchronously.

Normally, you should leave the Initiate Sync Negotiation setting enabled, because most SCSI devices support sync negotiation and because it allows for faster data transfer.

NOTE: Some older SCSI-1 devices do not support sync negotiation. This may cause your computer to operate erratically or hang if Initiate Sync Negotiation is set to Yes. Set Initiate Sync Negotiation to No for these devices.

- **Maximum Sync Transfer Rate.** This option sets the maximum synchronous data transfer rate that the host adapter supports. The host adapter supports rates up to the maximum of 40 megabytes per second (MB/sec). The default setting is 40 MB/sec (the maximum).

If the host adapter is set to not negotiate for synchronous data transfer, the maximum synchronous transfer rate is the maximum rate that the host adapter accepts from the device during negotiation. (This is standard SCSI protocol.)

- **Enable Disconnection.** This option (sometimes called *disconnect/reconnect*) determines whether the host adapter allows the SCSI device to disconnect from the SCSI bus. Enabling disconnection allows the host adapter to perform other operations on the SCSI bus while the SCSI device is temporarily disconnected. The default setting is Yes.

Leave Enable Disconnection set to Yes if two or more SCSI devices are connected to the host adapter. This optimizes SCSI bus performance. If only one

SCSI device is connected to the host adapter, set Enable Disconnection to No to achieve slightly better performance.

- **Initiate Wide Negotiation.** This option determines whether the host adapter attempts 16-bit data transfer instead of 8-bit data transfer. The default setting is Yes.

NOTE: Some 8-bit SCSI devices may have trouble handling wide negotiation, which may result in erratic behavior or a hang condition. For these devices, set Initiate Wide Negotiation to No.

When this option is set to Yes, the host adapter attempts 16-bit transfer. When this option is set to No, 8-bit data transfer is used unless the SCSI device itself requests wide negotiation. The effective transfer rate is doubled when 16-bit data transfer is used because the data path for wide SCSI is twice the size of normal 8-bit SCSI.

- **Send Start Unit Command.** This option determines whether the **start unit** command is sent to the SCSI device at boot. The default setting is Yes.

Setting this option to Yes reduces the load on your computer's power supply by allowing the host adapter to start SCSI devices one at a time when you boot your computer. When this option is set to No, the devices are allowed to start at the same time. Most devices require you to set a jumper before they can respond to this command.

NOTE: For many devices, if Send Start Unit Command is set to Yes, the boot time will vary depending on how long it takes each drive to start.

Advanced Host Adapter Settings

The advanced host adapter settings should *not* be changed unless absolutely necessary. Dell sets these values and changing them may cause conflicts with the SCSI devices.

- **Host Adapter BIOS.** This option enables or disables the host adapter BIOS. The default setting is Enabled.

NOTE: Several SCSISelect options are not valid unless the host adapter BIOS is enabled.

If you are booting from a SCSI hard-disk drive connected to the host adapter, the BIOS must be enabled.

You should disable the host adapter BIOS if the peripherals on the SCSI bus (for example, CD-ROM drives) are all controlled by device drivers and do not need the BIOS.

- Support Removable Disks Under BIOS as Fixed Disks. This option controls which removable-media drives are supported by the host adapter BIOS. The default setting is Boot Only. The following choices are available.

CAUTION: If a removable-media SCSI device is controlled by the host adapter BIOS, do not remove the media while the drive is on or you may lose data. If you want to be able to remove media while the drive is on, install your removable-media device driver and set this option to Disabled.

- Boot Only. Only the removable-media drive designated as the boot device is treated as a hard-disk drive.
 - All Disks. All removable-media drives supported by the BIOS are treated as hard-disk drives.
 - Disabled. No removable-media drives are treated as hard-disk drives. In this situation, software drivers are needed because the drives are not controlled by the BIOS.
- Extended BIOS Translation for DOS Drives > 1 GB. This option determines whether extended translation is available for SCSI hard-disk drives with capacities greater than 1 gigabyte (GB). The default setting is Enabled.

CAUTION: Back up your hard-disk drive before you change the translation scheme. All data is erased when you change from one translation scheme to another.

The standard translation scheme for SCSI host adapters provides a maximum accessible capacity of 1 GB. To support hard-disk drives larger than 1 GB, the 78xx series host adapters include an extended translation scheme that supports hard-disk drives as

large as 8 GB under MS-DOS, with a maximum partition size of 2 GB.

Extended BIOS translation is used only with MS-DOS 5.0 or later. It is not necessary to enable this option if you are using another operating system such as NetWare.

When you partition a hard-disk drive larger than 1 GB, use the MS-DOS **fdisk** utility as you normally would. Because the cylinder size increases to 8 MB under extended translation, the partition size you choose must be a multiple of 8 MB. If you request a size that is not a multiple of 8 MB, **fdisk** rounds up to the nearest whole multiple of 8 MB.

- Display <Ctrl><a> Message During BIOS Initialization. This option determines whether the Press <Ctrl><a> for SCSISelect (TM) Utility! message appears on your screen during system start-up. The default setting is Enabled. If this setting is disabled, you can still run the SCSISelect utility by pressing <Ctrl><a> after the host adapter BIOS banner appears.
- Multiple LUN Support. This option determines whether your system supports booting from a SCSI device that has multiple LUNs. The default setting is Disabled. Enable this option if your boot device has multiple LUNs.
- BIOS Support for Bootable CD-ROM. This option determines whether the host adapter BIOS provides support for booting from a CD-ROM drive. The default setting is Enabled.
- BIOS Support for INT 13 Extensions. This option determines whether the host adapter BIOS supports disks with more than 1024 cylinders. The default setting is Enabled.
- Support for ULTRA SCSI Speed. This option determines whether the host adapter supports the fast transfer rates (20.0 to 40.0 megabits per second [Mbps]). The default setting is Enabled.

Starting the SCSISelect Utility

You can start the SCSISelect utility by pressing <Ctrl><a> when the following prompt appears briefly at boot time:

```
Press <Ctrl><a> for SCSISelect (TM)
Utility!
```

The first menu displays the Configure/View Host Adapter Settings and SCSI Disk Utilities options.

Using SCSISelect Menus

SCSISelect uses menus to list options you can select. To select an option, use the up- and down-arrow keys to move the cursor to the option; then press <Enter>.

In some cases, selecting an option displays another menu. You can return to the previous menu at any time by pressing <Esc>. To restore the original SCSISelect default values, press <F6>.

Using the SCSI Disk Utilities

To access the SCSI disk utilities, select the SCSI Disk Utilities option from the menu that appears when you start SCSISelect. Once the option is selected, SCSISelect immediately scans the SCSI bus (to determine the devices installed) and displays a list of all SCSI IDs and the devices assigned to each ID.

When you select a specific ID and device, a small menu appears, displaying the Format Disk and Verify Disk Media options.

- **Format Disk.** This option runs a utility that allows you to perform a low-level format on a hard-disk drive. Most SCSI disk drives are formatted at the factory and do not need to be formatted again. The Adaptec Format Disk utility is compatible with the vast majority of SCSI disk drives.

CAUTION: The Format Disk option destroys all data on the hard-disk drive.

- **Verify Disk Media.** This option runs a utility that allows you to scan the media of a hard-disk drive for defects. If the utility finds bad blocks on the media, it prompts you to reassign them; if you select Yes, those blocks are no longer used. You can press <Esc> at any time to exit the utility.

Exiting SCSISelect

To exit SCSISelect, press <Esc> until a message prompts you to exit. (If you changed any 78xx series host adapter settings, you are prompted to save the changes before you exit.) At the prompt, select Yes to exit, and then press any

key to reboot the computer. Any changes you made in SCSISelect take effect after the computer boots. (You can select No at the prompt if you are not ready to exit SCSISelect.)

Installation for Windows NT

Read this section to find out about Windows NT operating system installation, including:

- Installing and/or updating the SCSI drivers for the Windows NT operating system
- Removing a host adapter
- Swapping a host adapter
- Restoring a configuration if Windows NT fails to boot

Installation Overview

This section provides the information needed to install and use the Dell SCSI drivers for the 78xx series of SCSI controllers with the Windows NT operating system.

The Windows NT 4.0 driver diskette you create for the Windows NT Server 4.0 operating system contains the files needed for driver installation. The `\scsi` subdirectory on the diskette contains the following files to be used with Windows NT Server 4.0:

- **aic78xx.sys** — Adaptec's 78xx Family driver for Windows NT
- **oemsetup.inf** — A file used by Windows NT Setup for driver installation
- **readme.txt** — A text file describing the Adaptec 78xx driver for Windows NT

If you are installing the Windows NT operating system for the first time, see the following subsection, "Installing Windows NT 4.0 and the Driver," to begin driver installation. If Windows NT is already installed in your system, see "Using Windows NT to Install or Update the Driver" found later in this section.

Installing Windows NT 4.0 and the Driver

The Windows NT 4.0 operating system has SCSI drivers for the Adaptec 78xx series of SCSI controllers integrated into the operating system. When you load the operating system software for the first time, the drivers are automatically loaded.

If Windows NT 4.0 is already installed and you wish to install or update the **aic78xx.sys** driver, see the next subsection, "Using Windows NT to Install or Update the Driver."

Using Windows NT to Install or Update the Driver

This section describes how to install or update the **aic78xx.sys** driver if the Windows NT 4.0 operating system is already installed.

Installing or Updating the Driver With Windows NT 4.0

Follow these instructions only if the Windows NT 4.0 operating system is already installed:

1. **Click the Start button, point to Settings, and then click the Control Panel.**
2. **Double-click the SCSI Adapters icon.**
3. **Click the Driver tab, and then click Add.**
4. **Click Have Disk.**
5. **In the Copy Manufacturer's Files From: field, type a:\scsi\ and click OK.**
6. **Select Adaptec AHA-294x/AHA-394x/AHA4944 or AIC-78xx PCI SCSI Controller (NT 4.0). Then click OK.**
7. **If the following message appears, click New to replace the existing driver:**

The driver(s) for this SCSI Adapter are already on the system. Do you want to use the currently installed driver(s) or install new one(s).

8. **If the following message appears, type a:\scsi\ in the dialog box and click OK:**

Please enter the full path to Adaptec's installation files.

These files are located in \SCSI on the Dell Windows NT 4.0 Driver diskette.

The driver is copied from the diskette to your system.

9. **Click Yes when prompted to restart the system.**

After the system reboots, the new driver is active. Some drive letter assignments may have changed from the previous configuration.

Removing a Host Adapter

Removing a PCI expansion-card SCSI controller is as simple as physically removing it from its slot when your computer is shut down. The Windows NT operating system boots and functions properly in this configuration, but a warning message is generated every time you boot the operating system.

CAUTION: If you have removed a host adapter but still have other host adapters of the same type installed in your computer, do *not* use Windows NT Setup to remove the device driver.

To eliminate the warning message, you must update the Windows NT software configuration as follows:

1. **Select and start the Windows NT Setup program.**

There is a brief pause while Windows NT Setup scans your hardware configuration.
2. **Select the Options pull-down menu, and then select Add/Remove SCSI Adapters.**

The SCSI Adapter setup program displays a list of all host adapters currently installed.
3. **Select the host adapter you want to remove, and click Remove. When the Windows NT Setup program asks you for confirmation, click OK.**

Because SCSI device drivers are loaded during system start-up and because they may be needed to load the Windows NT operating system itself, a screen

may appear warning you that Windows NT may not start if you remove the SCSI adapter.

4. **When you are sure you are removing the correct host adapter type, click OK.**
5. **Return to step 3 if you want to remove driver support for other types of host adapters, or click Close to exit the SCSI adapters portion of Windows NT Setup.**
6. **Close the Windows NT Setup program. When the following message appears, click OK to exit:**

The changes you have made will not take effect until the computer is restarted.

If this message does not appear, no changes have been made to the Windows NT system configuration.

7. **Restart your computer.**

NOTE: The Windows NT Setup program does not delete the device driver from your hard-disk drive; it only updates Windows NT software configuration information so that the device driver is no longer loaded during system start-up.

Swapping a Host Adapter

The procedure for swapping one type of host adapter for another is similar to the procedure for adding a host adapter, except that you make all software configuration changes while the Windows NT operating system is running, *before* you make the hardware changes.

1. **Install the driver for the new host adapter by following the steps in “Installing or Updating the Driver With Windows NT 4.0” found earlier in this section.**

It is not essential to remove the device driver for the host adapter you are replacing. The Windows NT operating system dynamically detects the absence or presence of host adapter hardware, and no problems should arise if you leave the existing device driver installed. You can remove the device driver later, after you have successfully rebooted the Windows NT operating system. However, the system alerts you with an error message about the extra device driver every time you boot. See the previous subsection, “Removing a Host Adapter.”

2. **Once the new device driver is installed, shut down the Windows NT operating system and replace the existing host adapter.**
3. **Restart your computer and the Windows NT operating system.**

Some drive letter assignments may have changed from the previous configuration.

Troubleshooting for Windows NT

The boot manager for Windows NT contains recovery logic to allow you to return to the last known good configuration. If you have changed your host adapter configuration and the Windows NT operating system no longer boots, follow these steps to recover:

1. **Undo any hardware changes you have made to the computer since it was last operational.**
2. **Reboot the computer. Watch the display carefully during start-up. If the following message appears, press the <Spacebar> and follow the instructions on the screen to continue booting with the last known good configuration:**

Press spacebar NOW to invoke the Last Known Good menu

Type 1 to continue booting your computer.

3. **Once your computer is operational again, check all of the hardware and software configuration changes you want to make.**

Look specifically for conflicts with parts of the existing system configuration that are not being changed.

If you cannot determine the source of the error, contact Dell for assistance. See the chapter titled “Getting Help” in the *Diagnostics and Troubleshooting Guide* for instructions on contacting Dell for technical assistance.

Installation for Novell NetWare

Read this section to find out about the NetWare operating system installation, including:

- Installing the EZ-SCSI utility
- Calculating the slot number

- Installing and/or updating the Dell SCSI driver for NetWare
- Using command line options that can be specified when the driver is loaded
- Automatic driver loading using **startup.ncf** and **autoexec.ncf**
- Booting a NetWare server from a SCSI drive, formatting media, and using removable media
- Error messages generated during initialization

Installation Overview

This section provides the information needed to install and use the Dell SCSI drivers for NetWare 4.11. The Dell SCSI drivers for NetWare support the optional Adaptec AHA-2940UW and all Adaptec 78xx series SCSI controllers.

Before you begin installation of the SCSI drivers for NetWare, you must create a diskette of drivers for the version of NetWare you are using (4.11) and a diskette that contains the Adaptec EZ-SCSI utility. Chapter 2, “Using the Dell Server Assistant CD,” provides instructions for creating these diskettes.

NOTE: Be sure to use the SCSI driver diskettes created from the Dell Server Assistant CD rather than the SCSI drivers provided with the operating system.

The Dell SCSI drivers for NetWare are fully NetWare-tested and approved. The `\scsi` subdirectory on the NetWare 4.11 drivers diskette you create contains files to be used with NetWare 4.11. The following files appear in the `\scsi` subdirectories on both NetWare driver diskettes:

- **readme.txt** — An American Standard Code for Information Interchange (ASCII) text file describing Adaptec’s drivers for NetWare
- **aic7870.dsk** — Adaptec’s 78xx Family driver for NetWare
- **aspitran.dsk** — Adaptec’s ASPI[®] transport layer driver for NetWare
- **aspicd.dsk** — Adaptec’s device driver for a CD-ROM drive

In addition, the `\scsi` subdirectory on your NetWare 4.11 drivers diskette contains the following files:

- **aic7870.ddi** — A driver definition information file to provide setup information to NetWare during installation; NetWare can then prompt you with parameters to be configured for the device driver during the installation process.
- **aspicd.ddi** — A device driver definition file.
- **aspitran.ddi** — A device driver definition file.

To begin driver installation, first load the EZ-SCSI utility as described in the following subsection, “Installing EZ-SCSI,” and then calculate the slot number as described in “Calculating the Slot Number” found later in this section. Then, if you are installing NetWare for the first time, see “Installing NetWare and the Driver” found later in this section. If NetWare is already installed on your system, see “Using NetWare to Install or Update the Driver” found later in this section.

NOTE: Your system must have a complete version of MS-DOS (version 6.2x) installed before you can complete the NetWare installation.

Installing EZ-SCSI

The Adaptec EZ-SCSI utility automatically configures the computer to use an Adaptec SCSI host adapter and the devices connected to it. The Adaptec EZ-SCSI utility also copies applications and device drivers to the computer’s hard-disk drive. The configuration and installation process is explained with a series of screens. In most cases, the computer and SCSI devices are configured to take full advantage of all the performance benefits of SCSI when you accept the default values suggested by these screens.

Follow these steps to install the Adaptec EZ-SCSI utility:

1. **If you have not already done so, create an Adaptec EZ-SCSI diskette for the version of NetWare you are using.**

Chapter 2, “Using the Dell Server Assistant CD,” provides instructions for creating this diskette.

2. **Insert your Adaptec EZ-SCSI diskette into drive A.**

3. **Type `dosinst` and press <Enter>.**

A message appears while the EZ-SCSI utility loads into memory.

4. When the first EZ-SCSI screen appears, read the text carefully.

You can press <F1> on any screen for additional help. Press <Esc> to exit a Help screen.

5. Press <Enter> to continue with the installation.

6. Follow the instructions that appear on the screen. Press <Enter> at every screen to accept the EZ-SCSI default values.

If you accept all the default values, the EZ-SCSI utility copies the files from the diskette to the `c:\scsi` directory. (The EZ-SCSI utility creates this directory if the directory does not already exist.) The EZ-SCSI utility also adds command lines to your computer's configuration files (**autoexec.bat** and/or **config.sys**) that will load the required device drivers into memory when you boot your computer.

Press <Esc> to continue after the EZ-SCSI utility enters changes to your system configuration files.

If you want to copy the files to a different directory or control the changes to your configuration files, follow the instructions on the screen. Press <F1> on any screen to see more information.

*NOTE: If the EZ-SCSI utility is unable to locate the **mscdex.exe** file in the `c:\dos` directory, it will prompt for a pathname to access this file. (Without this file, the utility cannot access the computer's CD-ROM drive.)*

When the message (Adaptec EZ-SCSI has been successfully installed...) appears on the screen, press <Enter> or <Esc> to exit the EZ-SCSI utility, and remove the Adaptec EZ-SCSI diskette from the drive. Then reboot your computer by pressing <Ctrl><Alt>.

Calculating the Slot Number

The slot number is used to uniquely identify each Adaptec 78xx Family host adapter installed in your system. To properly load the driver for each Adaptec 78xx host adapter, you need to calculate the slot number and include it as part of the **load** command line.

NOTE: The NetWare operating system automatically calculates the slot number for you if you are installing only one expansion card. If you are installing multiple

expansion cards, use the following procedure to calculate the slot number.

In order to calculate the slot number, you must first obtain the *bus:device xx:xxh* values identified when running the *SCSISelect* utility for your host adapter. This calculation is done manually, as described in the following steps:

- 1. Make sure your system is properly set up and configured.**
- 2. Run the SCSISelect utility for your host adapter.**
See "The SCSISelect Utility" found earlier in this chapter for general instructions.
- 3. The first screen of the SCSISelect utility displays the bus:device xx:xxh numbers in the upper right-hand corner. Write down these numbers exactly as they appear.**

The *bus* variable refers to the PCI bus on the system. The default for *bus* is 0. Usually only one PCI bus is supplied with a system; however, systems may contain more than one PCI bus. The *device* variable refers to the physical slot number on the PCI bus. The device number is in hexadecimal; you must convert it to a decimal number.

*NOTE: The device slot number identified through SCSISelect is not the same as the slot number needed to load the driver through the **load** command line.*

Use the following formula to calculate the slot number:

$$\text{slot number} = (\text{bus} * 100) + \text{device} + 16$$

For example, if the *bus:device* number is 0:06h (that is, 0:6), then the slot number is 22 (22 = [0 * 100] + 6 + 16).

Installing NetWare and the Driver

This subsection describes how to install the **aic7870.dsk** driver at the same time you install NetWare 4.11. If NetWare 4.11 is already installed and you wish to install or update the **aic7870.dsk** driver, see "Using NetWare to Install or Update the Driver" found later in this section.

Performing a NetWare 4.11 Installation

Follow these steps only if you are installing or upgrading NetWare 4.11 for the first time:

1. **Make backup copies of all Novell diskettes, and use those backup copies as your working diskettes.**
2. **Boot MS-DOS on your computer.**
3. **Change to the directory where the installation files are found. For a CD-ROM, the subdirectory is similar to d:\netware4.0\english\.**
4. **Type `install` and press <Enter>.**
5. **Select Install New Netware V4.x if you are installing NetWare 4.11 for the first time, or Upgrade Netware V4.x if you are upgrading to NetWare 4.11.**
6. **Follow the instructions in the NetWare user's guide for partitioning, creating a server name, and checking the internetwork packet exchange (IPX) network number.**
7. **When a screen appears asking you to select a disk driver, press <Insert>.**

8. **Insert the NetWare 4.11 driver diskette that you created earlier into the diskette drive.**

If you have not already created this diskette, refer to Chapter 2, "Using the Dell Server Assistant CD," for instructions.

9. **Press <F3>, and specify the path to the `aic7870.dsk` driver for NetWare (for example, `a:\scsi`).**
10. **Select the `aic7870.dsk` driver and press <Enter>.**

NOTE: Specific help text for each driver appears in the middle of the screen as you scroll down the list. The Loaded Drivers window below the list of available drivers displays the names of drivers that are loaded and operational. For a new installation, this list is initially empty. For a selective installation, the list shows the diskette drivers already running.

11. **Specify the server directory (usually, `c:\nwserver`) and press <Enter>. The installation program copies the necessary files to this directory.**

12. **When the screen displays Loading driver `aic7870.dsk`, Please Wait, switch to the System Console screen.**

Press <Alt><Esc> to switch screens.

13. **The driver prompts you for the slot number. Enter the slot number you calculated for your host adapter, and press <Enter>. (See "Calculating the Slot Number" found earlier in this section.) You are automatically switched back to continue with the installation.**
14. **When you have correctly entered the slot number, press <F10> to load the driver.**
15. **If you are using multiple host adapters in your server, you must load the driver again for each host adapter.**

NOTE: If your system has multiple host adapters, each host adapter must have its own SCSI bus, and its hardware must be configured properly for use with multiple adapters. See the instructions in the host adapter's user's guide.

Refer to the NetWare user's guide for information on installing other NetWare Loadable Modules (NLMs). If an error message appears when you attempt to load the driver, see "Troubleshooting for NetWare" found later in this section.

16. **Select Continue the Installation to create disk partitions and system volumes, and to specify volume names following the procedures listed in the NetWare user's guide.**
17. **To load the driver automatically at server startup, make sure the `startup.ncf` file includes the load command line and correct slot number for your host adapter. See "Using `startup.ncf` and `autoexec.ncf`" found later in this section.**

Using NetWare to Install or Update the Driver

This section describes how to update or install the `aic7870.dsk` driver if NetWare 4.11 is already installed. If you are installing NetWare 4.11 for the first time, see "Installing NetWare and the Driver" found earlier in this section.

1. **Make a backup copy of the old driver (if it exists) before installing the new driver.**

2. **Copy the `aic7870.dsk` driver and `aspitrans.dsk` module from the NetWare 4.11 driver diskette you created into the server's start-up directory (usually, `c:\nwserver`) on your hard-disk drive.**

Doing so overwrites any existing version of the drivers in the directory.

NOTE: The `aic7870.dsk` and `aspitrans.dsk` files are located in the `\scsi` subdirectory on the diskette.

3. **If necessary, modify the load command line in the `startup.ncf` file so that the proper path to the driver and the correct slot number are specified. See "Using `startup.ncf` and `autoexec.ncf`" found later in this section.**

The correct syntax to load the Adaptec 78xx driver follows:

```
load [pathname] aic7870.dsk [options] slot=x
```

Command line options are not case sensitive. Placing commas between command line options is optional. See the next subsection, "Using the load Command Line Options," for optional values. To calculate the slot number for each host adapter, see "Calculating the Slot Number" found earlier in this section.

4. **Load the driver for the first installed host adapter. If you have additional host adapters, you must load the driver separately for each host adapter.**

Using the load Command Line Options

You can specify several command line options when the driver is loaded. These are described in Table 3-2.

Table 3-2. load Command Line Options

Option	Values	Default	Description
slot=	10-41, 100-141, and so forth	None	Defines location of host adapter device. If none is given, you are prompted to specify one.
verbose=	y, n	n	Causes driver to display host adapter configuration information at load time.
removable=	on, off	on	Enables support for removable media. By default, removable media is supported. You may want to disable removable disk support in order to load an ASPI removable disk module.
fixed_disk=	on, off	on	Enables support for hard-disk drives. By default, hard-disk drives are supported. You may want to disable fixed disk support in order to load an ASPI fixed-disk module.
dev_enable=	00-FF*	FF	Allows you to enable the driver's registration of SCSI devices on a per-target basis. This enable bit mask is entered in hexadecimal format. (See the following subsection, "Bit Mask Options.")
lun_enable=	00-FF*	01	Enables scanning for specific LUNs on all targets. (See the following subsection, "Bit Mask Options," for details on creating bit masks.) For example, a value of 7 causes the driver to scan for LUNs 0, 1, and 2 on all targets. The default value of 01 causes the driver to scan LUN 0 only.

* On the AIC-7880 and optional AHA-2940UW, these values become FFFF.

NOTE: For the full name of an abbreviation or acronym used in this table, see the Glossary.

Table 3-2. load Command Line Options (continued)

Option	Values	Default	Description
tag_disable	00-FF*	00	Disables tagged queuing for specific targets. This disable bit mask is entered in hexadecimal format. (See the following subsection, “Bit Mask Options.”)
io_combine	0-255	16	Specifies the maximum number of segments in a scatter/gather list.
max_sectors	0-255	64	Specifies the maximum number of sectors in a single scatter/gather segment.
max_tags	0-255	8	Specifies the maximum number of tagged commands.
max_nontags	0-255	2	Specifies the maximum number of nontagged commands.
read_after_write	0, 1, 2	2	Specifies the default verify mode: 0 = No verify on writes, 1 = Software verify, 2 = Hardware verify.
instrumentation	0, 1	0	If 1 is entered, the instrumentation option is enabled. The driver maintains internal instrumentation data for use by I/O management applications. Instrumentation can also be enabled by the I/O management application, so inclusion of this option is not necessary.

* On the AIC-7880 and optional AHA-2940UW, these values become FFFF.

NOTE: For the full name of an abbreviation or acronym used in this table, see the Glossary.

Bit Mask Options

Use this example to aid in calculating bit-mask option hexadecimal values. Each SCSI device is enabled by a “1” in its corresponding bit position. As illustrated in Figure 3-1, **dev_enable=05** enables driver registration of the devices at SCSI IDs 0 and 2.

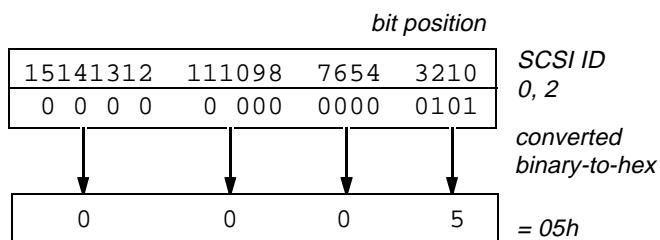

Figure 3-1. Bit Position

Sample load Command

The following command is a sample **load** command with no option switches (loaded from drive A):

```
load a:\scsi\aic7870.dsk
```

Slot values that already have another registered device do not appear on the screen. Only the slots available for use by the host adapter appear when this command is entered. If an error message appears as you attempt to load the driver, refer to “Troubleshooting for NetWare” found later in this section.

The following command is a sample command loading the **aic7870.dsk** driver with command line options (loaded from drive A):

```
load a:\scsi\aic7870.dsk verbose=y slot=22
```

Using startup.ncf and autoexec.ncf

The **startup.ncf** and **autoexec.ncf** files contain a set of commands that are executed at server start-up. The **startup.ncf** file contains commands to load the disk drivers. Once **startup.ncf** loads disk drivers, control is passed to the **autoexec.ncf** file to complete the boot process. For additional information on the **startup.ncf** and **autoexec.ncf** files, refer to your NetWare documentation.

To automatically load the **aic7870.dsk** at server start-up, the **startup.ncf** must contain a **load** command line that specifies the location of the driver on the hard-disk drive, any available options (see “Using the **load** Command Line Options” found earlier in this section), and the slot number (see “Calculating the Slot Number” found earlier in this section).

*NOTE: To load the driver from your hard-disk drive, the **aic7870.dsk** driver and **aspitran.dsk** module must be copied from your NetWare 4.11 driver diskette to a directory on your hard-disk drive (usually, the server's start-up directory—for example, **c:\nwserver**).*

The syntax to load the **aic7870.dsk** driver is:

```
load [pathname] aic7870.dsk [options] slot=x
```

For example, the command line to load the driver from the **c:\nwserver** directory, with the **verbose=** option on, and a slot number of 16 follows:

```
load c:\nwserver\aic7870.dsk verbose=y  
slot=16
```

*NOTE: For each Adaptec 78xx host adapter installed, a separate **load** command line must be included in the **startup.ncf** file. The slot number (**slot=**) identifies the specific adapter.*

To modify the **startup.ncf** file, follow these steps:

1. Type **install** at the NetWare prompt, and press <Enter>.
2. Select the appropriate menu choice that allows you to edit the **startup.ncf** file.
3. Make the necessary changes. When you are finished, press <F10>.

Using SCSI Devices

The following sections provide procedures and tips on the following topics:

- Booting from a SCSI device
- Formatting media
- Using removable media
- Using NetWare-tested and -approved drives
- Using the NetWare tape backup utility
- Using a CD-ROM drive with NetWare
- Optimizing performance

Booting From a SCSI Device

Follow these steps to set your system to boot from a SCSI device:

1. For an Adaptec 78xx host adapter, use the **SCSISelect** utility to configure your preferred boot device by setting the **Boot Target ID** option.
2. Use the **MS-DOS fdisk** utility to create a small **MS-DOS** partition. (Follow Novell's recommendation for size.)

MS-DOS must be loaded on sector 0 (zero) of the boot drive.
3. Format the drive using the **MS-DOS** format command (for example, **format c: /s**). Boot the system from this drive.
4. Copy the files shown in Table 3-3 to the root directory.

Table 3-3. Files Necessary to Boot From a SCSI Device

Diskette	Directory	Files
<i>NetWare System-1 diskette</i>	Root	server.exe install.nlm
<i>NetWare 4.11 driver diskette (created from CD)</i>	\scsi	readme.txt aic7870.dsk aspitran.dsk aic7870.ddi

5. **Reboot your server and execute the server.exe file.**
NetWare should start up at this point.
6. **Enter your file server name and internal IPX number.**

Formatting Media

NetWare's **install.nlm** program lets you optionally format a hard-disk drive for use with NetWare. If you are using SCSI drives, it allows you to low-level format several SCSI drives simultaneously. The NetWare format procedure is not the same as using **fdisk** or **format** under MS-DOS.

CAUTION: You should *not* use NetWare to format a hard-disk drive that contains partitions for other operating systems, because that information may be destroyed.

NOTE: When you select a hard-disk drive to format, the Install program prompts you to enter an interleave value from 1 to 9. You may also enter an interleave value of 0 (zero). When formatting SCSI hard-disk drives or removable drives on the Adaptec 78xx host adapter SCSI bus, Dell recommends that you use an interleave value of 0. This 0 interleave value instructs the hard-disk drive to use its optimal interleave value. This option was unavailable in NetWare 3.0.

Using Removable Media

The **aic7870.dsk** driver module fully supports removable-media disk drives, including magneto-optical drives. Removable media is treated as a standard SCSI hard-disk drive, with some exceptions:

- The driver only recognizes and registers media with 512 bytes/sector.
- NetWare allows you to mount or dismount the media and lock or unlock the media.

These removable media options are supported by NetWare's **monitor.nlm** program.

Follow these steps to set up the removable media:

1. **Load monitor.nlm to display the various options.**
2. **Select Disk Information. All system hard-disk drives appear.**

3. **Select the removable-media device. Drive status items appear as shown in Table 3-4.**

Table 3-4. Drive Status Items

Menu Options	Default Value
Volume Segments on Drive ¹	(select for list)
Read After Write Verify ¹	Hardware Level
Drive Light Status ¹	Not supported
Driver Operating Status ¹	Active
Removable Drive Mount Status ²	Mounted
Removable Drive Lock Status ²	Not Locked

¹ Valid for both removable and nonremovable types of SCSI drives.

² Valid for removable media only.

Mount Status

Mounting causes a drive to come online as a NetWare storage device. Dismounted drives are inactive and cannot be accessed.

Before you eject your current media, you should first dismount it by selecting the Removable Drive Mount Status option. Once the media status is dismounted, you can eject the media. However, NetWare does not allow you to dismount media that is locked.

To insert your new media, wait for the drive to spin up, and then select the Removable Drive Mount Status option.

Lock Status

If your removable-media device supports the lock/unlock feature, you can lock the media by selecting the Removable Drive Lock Status option. The media must be in the Not Locked state before you can eject it.

Verify Status

The Read After Write Verify option is set to Hardware Level by default. This option cannot be specified in the **startup.ncf** or **autoexec.ncf** file. However, the default

can be set on the command line (see “Using the **load** Command Line Options” found earlier in this section.) The available settings for this option are defined as shown in Table 3-5.

Table 3-5. Read After Write Verify Settings

Option Setting	Function
Disabled	All writes to SCSI disk drives are executed with the SCSI Write command (0Ah or 2Ah).
Hardware Level	All writes to SCSI disk drives are executed with the SCSI Write and Verify command (2Eh) or (if this command is not supported by the drive) with the SCSI Write command (0Ah or 2Ah), followed by the SCSI Verify command (2Fh).
Software Level	Not supported.

Using NetWare-Tested and -Approved Drives

In order for a drive and host adapter to be fully certified as NetWare “Yes, Tested and Approved,” they must both pass a qualification process that takes place before you see the product. The goals of NetWare testing are to simplify installation and provide the highest quality disk subsystem.

Adaptec 78xx Family host adapters and their drivers are fully NetWare-tested and -approved. This means that you can purchase a NetWare drive (certified as “Yes, Tested and Approved”) from a vendor, connect it to your computer system or host adapter, partition it, and create a volume without any compatibility concerns.

Adaptec’s **aic7870.dsk** driver module is flexible enough to allow you to connect NetWare-tested and -approved SCSI drives as well as standard SCSI drives to a single host adapter. The driver registers each hard-disk drive accordingly.

Drive registration is a user-transparent process; no user interaction is required. You can tell that the drive has been detected as NetWare-tested and -approved if the message **NetWare Yes Tested and Approved** is included in the drive description string that appears when you run **monitor.nlm** (disk options).

Using the NetWare Tape Backup Utility

Included with NetWare is a server-based tape backup utility called **sbackup.nlm**. This allows backup of server disk drives to a server tape drive. The **sbackup.nlm** utility supports Adaptec host adapters.

1. Load the SCSI adapter driver.

The syntax to load the **aic7870.dsk** driver is:

```
load [pathname] aic7870.dsk [options] slot=x
```

The ASPI layer (**aspitran.dsk**) is automatically loaded.

2. Refer to the Novell NetWare documentation for additional instructions on loading the server backup software. Refer to the *NetWare Server Backup User’s Guide* to load the **tsa** and **sbackup** modules.

Setting Up a CD-ROM Drive With NetWare 4.11

To use a CD-ROM drive with NetWare 4.11, follow these instructions:

1. Load **aic7870.dsk** by entering the following command line:

```
load [pathname] aic7870.dsk slot=x
```

2. Load **aspicd.dsk** by entering the following command line:

```
load [pathname] aspicd.dsk
```

*NOTE: If **aspicd.dsk** does not work, unload it and load it again. The first load initializes the host adapter; unloading and reloading allow the initialization to complete.*

3. Load **cdrom.nlm** as follows:

```
load [pathname] cdrom.nlm
```

4. Enter the following line at the prompt, and then note the number and name of the CD that appears:

```
cd device list
```

5. Enter the number and volume name of the CD at the command line:

```
cd mount [number] [name]
```

The CD-ROM is now ready to be accessed as a volume.

Optimizing Performance

The Adaptec 78xx SCSI bus master firmware increases the SCSI performance of the Adaptec 78xx Family host adapters under multitasking environments. The firmware uses a paging mechanism to handle up to 255 simultaneous SCSI commands. The sequencer can simultaneously manage up to 32 tagged, or 2 nontagged, SCSI commands for each SCSI device, up to a limit of 255 SCSI commands. The firmware can queue as many commands as the operating system is able to send to the host adapter. To set this feature, enter the following command:

```
max_tags=n
```

In general, a low number for the **max_tags** option gives better sequential performance. This value varies with the level of random disk accesses and drive characteristics.

*NOTE: A large value for **max_tags** can cause starvation problems with some drives.*

Troubleshooting for NetWare

Any error that occurs while the driver is initializing prevents it from loading. If an error does occur, the driver causes the computer to beep and then display a numbered error message:

```
xxx message
```

The *xxx* indicates the error code, and *message* is a descriptive line describing the error. The error codes are divided into three categories:

000-099: Nonhost adapters

100-299: Host adapters

300-999: Reserved

Specific error codes appear only if you have installed the host adapters and drivers that generate them.

Nonhost Adapters

```
000 Failed ParseDriverParameters call
```

A call to NetWare's ParseDriverParameters routine has failed for some unknown reason. The command line contains errors, or you pressed <Esc> at the port or slot prompt.

```
001 Unable to reserve hardware, possible conflict
```

The driver failed in its attempt to reserve the host adapter's hardware settings (that is, direct memory access

[DMA] and interrupt request [IRQ] settings). Another card in your system may be causing a conflict with the host adapter.

```
002 NetWare rejected card Failed AddDisk-System call
```

The driver failed in its attempt to register the host adapter with NetWare. The file server may not have enough memory.

```
003 Invalid command line option entered > option
```

An invalid option was entered on the command line. The invalid option that was entered is also displayed.

```
004 Invalid command line, please enter correctly
```

The driver was unable to understand the command line options you entered. Be sure you have entered these options correctly.

Host Adapters

```
200 No host adapter found for this driver to register
```

No Adaptec 78xx host adapter was found in your computer for the driver to register. Be sure the host adapter is properly configured and properly seated in the slot.

```
203 Invalid 'device' setting
```

You have entered an invalid slot setting on the command line. You can only enter slot numbers for valid host adapters. If you load without the slot option, you will be prompted to enter a valid value.

```
204 Invalid 'verbose' setting, use 'y'
```

You can only enter *y* for this option (**verbose = y**).

```
205 Invalid 'removable' setting, use 'off'
```

You can only enter *off* for this option (**removable = off**).

```
206 Invalid 'fixed_disk' setting, use 'off'
```

You can only enter *off* for this option (**fixed_disk = off**).

```
208 SCSI present but not enabled/configured for PCI
```

A host adapter is present, but its bus or device entry has not been enabled.

Chapter 4

Using the System Setup Program

Each time you turn on your computer system or press the reset button, the system compares the hardware installed in the system to the hardware listed in the system configuration information stored in nonvolatile random-access memory (NVRAM) on the system board. If the system detects a discrepancy between the two, it generates error messages that identify the incorrect configuration settings. The system then prompts you to enter the System Setup program to correct the setting.

You can use the System Setup program as follows:

- To change the system configuration information after you add, change, or remove any hardware in your system
- To set or change user-selectable options—for example, the time or date on your system

CAUTION: Whenever you make changes to the System Setup program or add, reposition, or remove Extended Industry-Standard Architecture (EISA) or Industry-Standard Architecture (ISA) expansion cards, add or remove memory, or change settings for built-in devices, you must run the EISA Configuration Utility, make any necessary changes, and save the system configuration information. Failure to do so may cause resource conflicts between Peripheral Component Interconnect (PCI) devices (such as PCI expansion cards, the built-in video controller, or the built-in small computer system interface [SCSI] host adapter). See “Configuring EISA, ISA, and PCI Expansion Cards” in Chapter 5 for more information about how PCI devices are configured based on settings in the EISA Configuration Utility.

When you save changes and exit the System Setup program, the system automatically reboots causing any changes to take effect immediately.

After you set up your system, run the System Setup program to familiarize yourself with your system configuration information and optional settings. Dell recommends that you print out the System Setup screens or write down the information for future reference.

Before you use the System Setup program, you need to know the kind of diskette drive(s) installed in your computer. (The standard diskette drive is a 1.44-megabyte [MB] 3.5-inch drive.)

System Setup Screens

The System Setup screens display the current setup and configuration information and optional settings for your system. Information on the System Setup screens is organized in five boxed areas:

- **Title Box**

The box at the top of each screen lists the system name, and the revision number of the basic input/output system (BIOS) as detected by the system.

- **Configuration Options and System Data**

The box on the left side of each screen lists categories that define the installed hardware in your system.

Fields beside the categories contain options or values.

System data that is not user-selectable is displayed in the lower part of the Main menu screen.

- **Help**

The box on the upper-right side of each screen displays help information for the category whose field is currently highlighted.

- **Key Functions**

The area at the bottom of each screen lists the keys and their specific functions, which are also listed in Table 4-1.

Table 4-1. System Setup Keys

























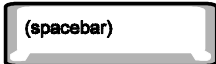

Keys	Action
 or  	Displays the general help window.
	Displays the Exit menu unless you are in a submenu. If you are in a submenu, pressing the <Esc> key displays the parent menu.
 or 	Moves the cursor to the next menu in each direction.
 or 	Moves the cursor up or down.
	Moves to the next field.
 	Moves to the previous field.
 or 	Moves the cursor to the top or bottom of the window.
 or 	Decrements the value of the field.

Table 4-1. System Setup Keys (continued)

Keys	Action
 or 	Increases the value of the field.
or  	
	Sets default configuration values for the current menu.
 	Loads the default System Setup values for all menus.
	Sets previous configuration values for the current menu.
	Executes the selected command or displays a submenu.
 	Refreshes the screen.

Entering the System Setup Program

You can enter the System Setup program by pressing the <F2> key when prompted while the computer is starting up.

If you wait too long, your operating system begins to load into memory. In this case, *let the system complete the load operation*; then restart the system and try again.

NOTE: To ensure an orderly system shutdown, consult the documentation that accompanied your operating system.

You can also enter the System Setup program by responding to certain error messages. (See “Responding to Error Messages” at the end of this chapter.)

The following sections describe the System Setup categories in the Main (see Figure 4-1), Advanced, Security, and Exit menus.

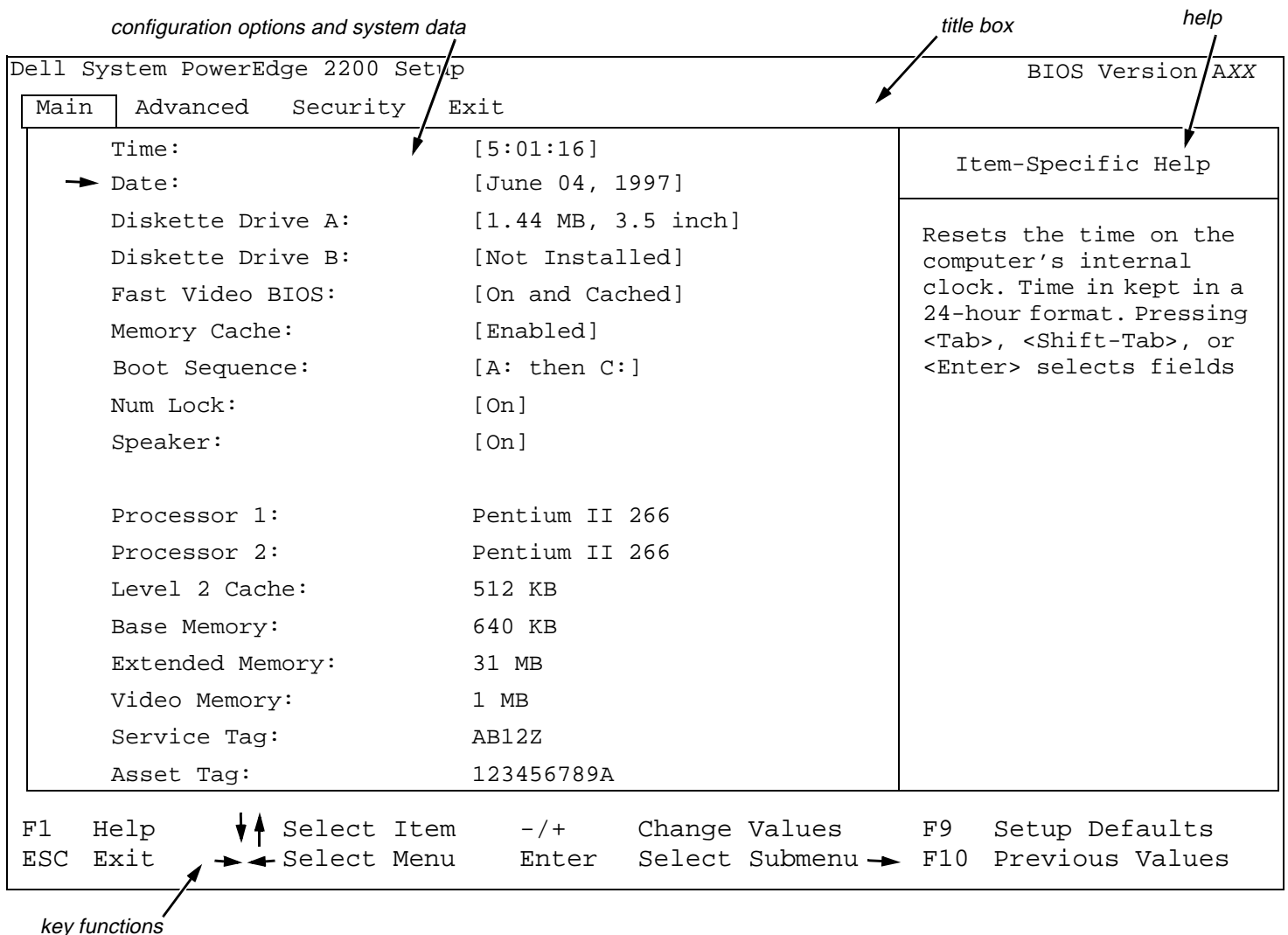

Figure 4-1. Main Menu of the System Setup Program

Main Menu Categories

To access the Main menu (see Figure 4-1), use the arrow keys to highlight Main. This section explains in detail each of the System Setup categories in the Main menu and the Boot Sequence submenu.

Time

Time resets the time on the computer's internal clock.

Time is kept in a 24-hour format (*hours:minutes:seconds*). To change the time, use the plus and minus keys. If you prefer, you can type numbers in each of the appropriate fields.

NOTE: If your system is connected to a network, the Time category may reflect the time maintained by the network server, depending upon how the network is configured. In this case, changing the Time category on your system has no effect.

Date

Date resets the date on the computer's internal calendar.

Your system automatically displays the day of the week corresponding to the settings in the three fields that follow (*month, day-of-the-month, and year*).

To change the date, use the plus and minus keys to increase and decrease the numbers. If you prefer, you can type numbers in the *day-of-the-month* fields.

NOTE: If your system is connected to a network, the Date category may reflect the date maintained by the network server, depending upon how the network is configured. In this case, changing the Date category on your system has no effect.

Diskette Drive A and Diskette Drive B

Diskette Drive A and Diskette Drive B identify the type of diskette drives installed in the drive cage.

The options for both categories are:

- 360 KB, 5.25 Inch
- 1.2 MB, 5.25 Inch
- 720 KB, 3.5 Inch
- 1.44 MB, 3.5 Inch (default for diskette A)
- Not Installed (default for diskette B)

Fast Video BIOS

Fast Video BIOS offers the options of shadowing and/or caching the video BIOS for improved performance.

For the built-in video controller chip, the Fast Video BIOS category offers the following options:

- On and Cached (the default)
- On
- Off

If you choose the On option, your system boots and immediately copies the video BIOS code from the flash memory chip into write-protected memory locations in faster random-access memory (RAM). This process is known as shadowing. If you choose On and Cached (the default), your system boots and not only shadows the video BIOS code, but also allows it to be cached. Caching saves time for the microprocessor(s) by holding available the most recently accessed data and instructions in an intermediate storage area of static RAM (SRAM), which is faster than system RAM. Shadowing and caching let the system manipulate video display data more quickly and easily, improving video performance.

Memory Cache

Memory Cache can be set to Enabled (the default) or Disabled.

Cache memory decreases the average memory cycle time to boost system performance. You may want to set Memory Cache to Disabled to aid in troubleshooting software problems.

Boot Sequence

The Boot Sequence category can be set to A: then C: (the default), C: then A:, or C: Only.

The term *boot* refers to the system's start-up procedure. When turned on, the system "bootstraps" itself into an operational state by loading into memory a small program which in turn loads the necessary operating system. Boot Sequence tells the system where to look for the files that it needs to load.

Selecting A: then C: causes the system to try booting from drive A first. If it finds a diskette that is not bootable in the drive or finds a problem with the drive itself, the system displays an error message. If it does not find a diskette in the drive, the system then tries to boot from the hard-disk drive (drive C).

Selecting C: Only causes the system to boot *only* from the hard-disk drive, even if there is a bootable diskette in drive A. You might select the C: Only option to prevent an unauthorized person from accessing the system by booting from a diskette.

Boot Options Submenu Categories

To access the Boot Options submenu (see Figure 4-2), highlight the Boot Sequence category in the Main menu and press <Enter>.

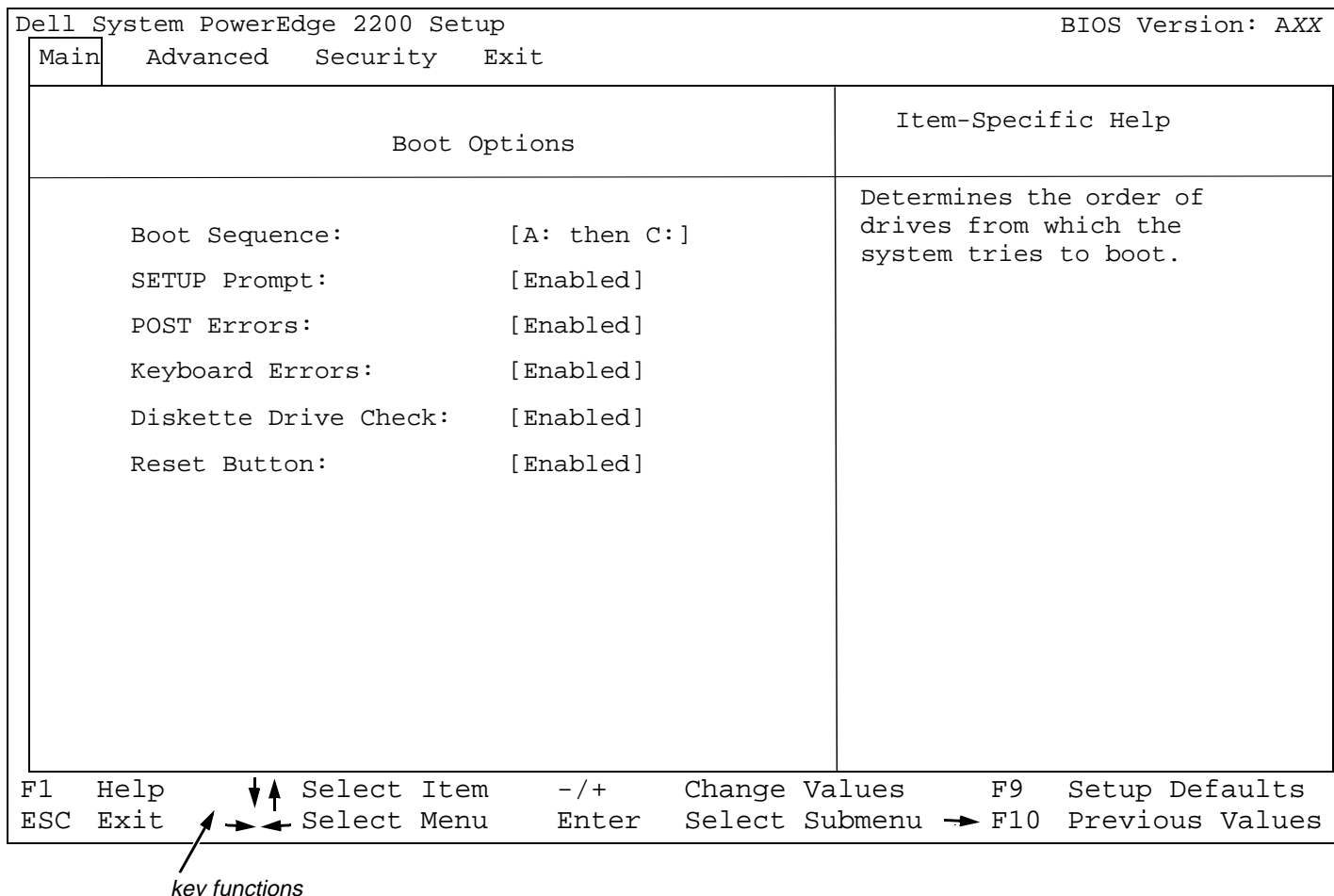

Figure 4-2. Boot Options Submenu

Setup Prompt

Setting this category to Enabled (the default) causes the message `Press <F2> to enter Setup` to appear while the system is starting up.

POST Errors

Setting this category to Enabled (the default) causes the message `Press <F1> to resume, <F2> to enter Setup` to appear and the system to pause if an error occurs while the system is starting up.

Diskette Drive Check

Setting this category to Enabled (the default) causes the system to seek diskette drives during system start-up. Setting this category to Disabled speeds system start-up time.

Reset Button

Setting this category to Enabled (the default) will reset the system when the reset button is pushed.

Num Lock

This category controls the state of Num Lock at system boot. When Num Lock is set to On, the rightmost bank of keys on your keyboard provides the mathematical and numeric functions shown at the top of each key. When the Num Lock mode is turned off, these keys provide cursor-control functions according to the labels on the bottom of each key.

Speaker

Use this category to set the built-in speaker On (the default) or Off.

Processor 1 and Processor 2

Identify the type of microprocessor(s) installed in the computer. These categories have no user-selectable options.

Level 2 Cache

Displays the amount of integrated level-2 cache memory in the microprocessor module. This category has no user-selectable options.

Base Memory

Base Memory displays the amount of memory available to MS-DOS programs that do not use extended or expanded memory. This category has no user-selectable options.

The default value for the Base Memory category is 640 KB, which includes 1 kilobyte (KB) reserved for system use.

The value given in the Base Memory category is in kilobytes rather than megabytes. To convert kilobytes to megabytes, divide the kilobyte total by 1024.

Extended Memory

Extended Memory (which has no user-selectable options) indicates the amount of system memory available as extended memory.

The value given in the Extended Memory category is in megabytes.

Video Memory

Displays the amount of video memory installed in the built-in video subsystem. This category has no user-selectable options.

Service Tag

Service Tag displays the system's five-character service tag number, which Dell programmed into NVRAM during the manufacturing process. Reference this number during technical assistance or service calls. The service tag number is also accessed by certain Dell support software, including the diagnostics software.

Asset Tag

Asset Tag displays the asset tag number stored in the computer's NVRAM. An asset tag number can have up to 10 alphanumeric characters. See "Asset Tag Utility" in Chapter 2 for information on loading the asset tag utility.

Advanced Menu Categories

To access the Advanced menu (see Figure 4-3), use the arrow keys to highlight Advanced. This section explains in detail each of the System Setup categories in the Advanced menu.

The Advanced menu allows you to set the COM and LPT addresses, set the LPT mode, enable or disable the on-board diskette controller, enable the PS/2 mouse, and enable or disable the built-in SCSI controller. The Advanced menu also lets you control the PCI scan sequence. The PCI scan sequence determines which type of PCI device is scanned first: built-in PCI drives or PCI devices installed in PCI expansion slots.

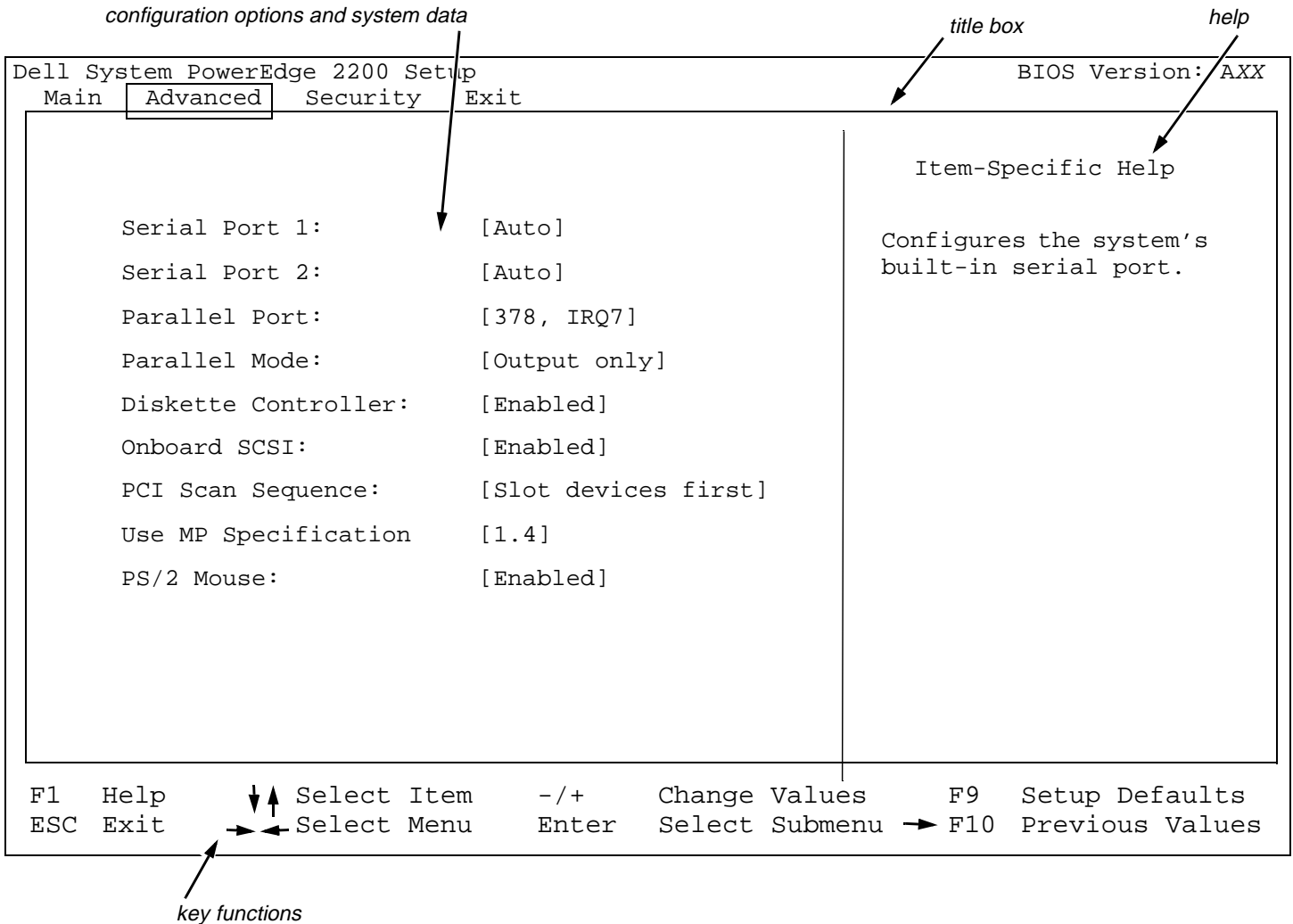

Figure 4-3. Advanced Menu of the System Setup Program

Serial Port 1

Use this category to select a unique address and interrupt request for the listed COM ports. The options are as follows:

- Disabled
- 3F8, IRQ4
- 3E8, IRQ4
- Auto (the default)

The Auto option selects the next available combination.

Serial Port 2

Use this category to select a unique address and interrupt request for the listed COM ports. The options are as follows:

- Disabled
- 2F8, IRQ3
- 2E8, IRQ3
- Auto (the default)

The Auto option selects the next available combination.

Parallel Port

Use this category to select a unique address and interrupt request for the listed LPT ports. The options are as follows:

- Disabled
- 378, IRQ5
- 3BC, IRQ7
- 278, IRQ5
- 378, IRQ7 (the default)
- Auto

The Auto option selects the next available combination.

Parallel Mode

This category allows you to select from the following options: Output Only (AT-compatible) (the default), Bi-directional (Personal System/2 [PS/2]-compatible), and ECP (extended capabilities port).

Diskette Controller

Selecting Enabled (the default) enables the on-board diskette drive controller.

Onboard SCSI

Selecting the Enabled (the default) option enables the on-board PCI SCSI controller and scans the associated ROM. In order for the system to boot from a drive attached to the on-board SCSI controller, the drive must be enabled. Selecting Disabled causes the BIOS to mask the presence of a device.

PCI Scan Sequence

This category determines the order in which PCI devices are scanned by the system, and it allows you to select the built-in SCSI controller or an optional PCI expansion card SCSI controller as the boot device. The options are:

- Embedded Devices First
- Slot Devices First (the default)

Use MP Specification

This category configures the Multiprocessor Specification revision level. The default value is 1.4. Some operating systems require level 1.1 for compatibility reasons.

PS/2 Mouse

Setting PS/2 Mouse to Enabled (the default) allows an installed PS/2 mouse to function. Disabling PS/2 Mouse frees interrupt request (IRQ) 12, but it also prevents any installed PS/2 mouse from functioning.

Security Menu Categories

To access the Security menu (see Figure 4-4), use the arrow keys to highlight Security. This section explains in detail each of the System Setup categories in the Security menu.

Dell System PowerEdge 2200 Setup		BIOS Version AXX
Main	Advanced	Security Exit
Supervisor Password is:	Disabled	<p>Item-Specific Help</p> <p>Pressing <Enter> displays a dialog box for entering the supervisor (7-digit, alphanumeric) password. This password gives full access to the Setup menu. The supervisor password must be enabled before the user password can be set.</p>
User Password is:	Disabled	
Set Supervisor Password:	[Press Enter]	
Set User Password:	[Press Enter]	
Password on Boot:	[Disabled]	
Diskette Access:	[User]	
System Backup Reminder:	[Disabled]	
Virus Check Reminder:	[Disabled]	
F1 Help	↓↑ Select Item	-/+ Change Values
ESC Exit	→← Select Menu	Enter Select Submenu
		F9 Setup Defaults
		F10 Previous Values

key functions

Figure 4-4. Security Menu of the System Setup Program

Supervisor Password Is

This category displays whether the supervisor password is disabled or enabled. When Enabled is displayed, the supervisor password has already been set and is required in order to have full access (see Table 4-2) to the System Setup program. The default is Disabled.

User Password Is

This category displays whether the user password is disabled or enabled. When Enabled is displayed, the user password has already been set and is required at start up. Unlike the supervisor password, the user password does not allow you full access (see Table 4-2) to the System Setup program. The default is Disabled.

Set Supervisor Password

The Set Supervisor Password category lets you restrict access to your computer's System Setup program in the same way that you restrict access to your system with the user password feature.

NOTE: Read "Using the Supervisor Password Feature" found later in this chapter for detailed instructions on assigning a supervisor password and using, deleting, or changing an existing supervisor password. See "Disabling a Forgotten Password" found later in this chapter for information on disabling a forgotten supervisor password.

Set User Password

NOTE: You cannot set the user password until a supervisor password is set.

The Set User Password category lets you restrict access to your system by setting a user password that is required when the Password On Boot category is set to Enabled.

NOTE: Read "Using the User Password Features" found later in this chapter for detailed instructions on assigning a user password and using, deleting, or changing an existing user password. See "Disabling a Forgotten Password" found later in this chapter for information on disabling a forgotten user password.

Password on Boot

The Password On Boot category allows you to require a supervisor password during the boot-up process when the category is set to Enabled. The default is Disabled.

Diskette Access

The Supervisor setting restricts access of diskette drives to the supervisor only. The User setting (the default) allows access to the supervisor and the user.

System Backup Reminder

This category lets you display a message during start-up at selected intervals to remind you to back up the system. The options are as follows:

- Disabled (default)
- Daily
- Weekly
- Monthly

Virus Check Reminder

This category lets you display a message during start-up at selected intervals to remind you to check your system for viruses. The options are as follows:

- Disabled (default)
- Daily
- Weekly
- Monthly

Exit Menu Categories

To access the Exit menu (see Figure 4-5), use the arrow keys to highlight Exit. The following section explains in detail each of the System Setup categories in the Exit menu.

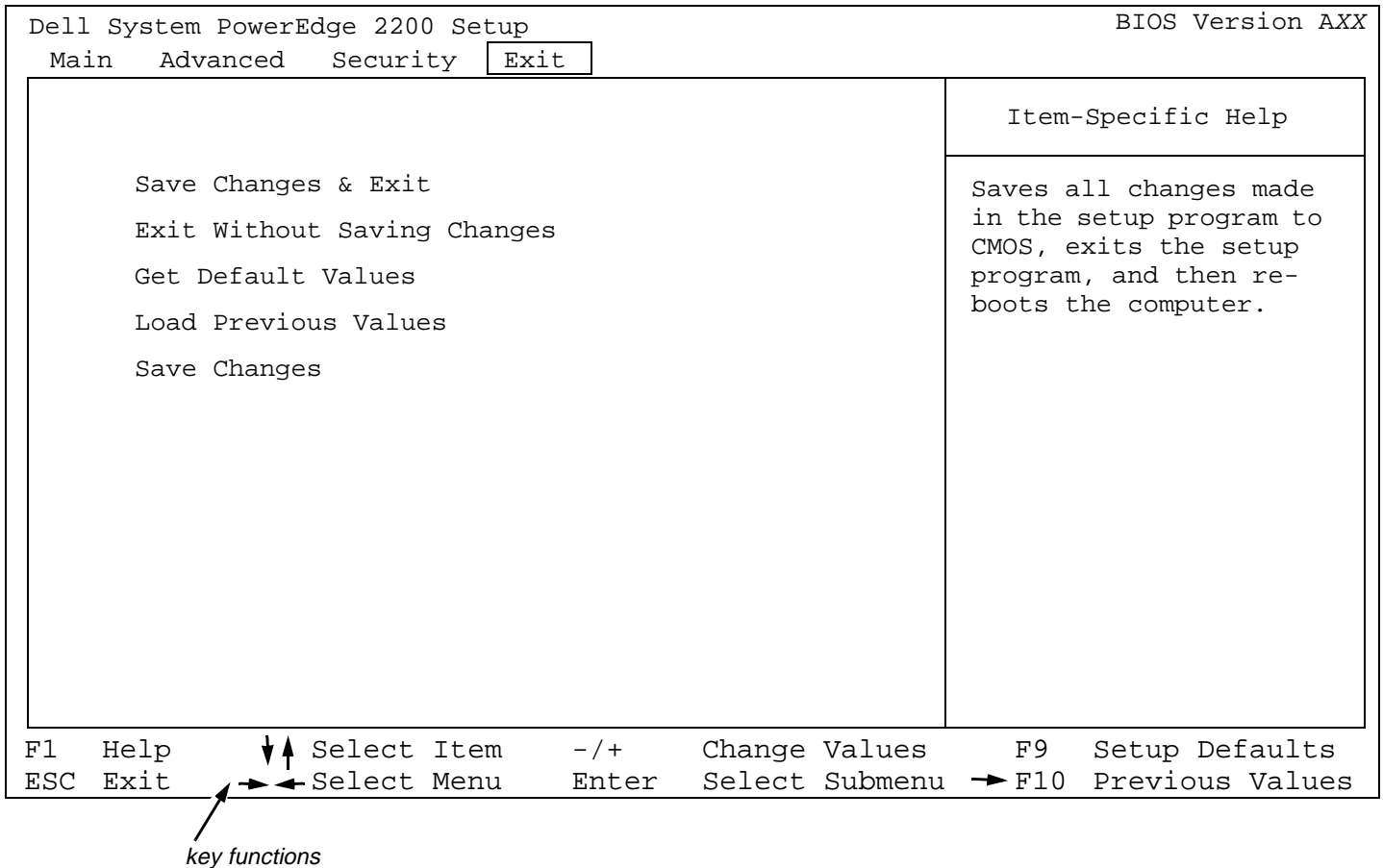

Figure 4-5. Exit Menu of the System Setup Program

Save Changes & Exit

When you choose this option, the BIOS stores the changes you have made in a complementary metal-oxide semiconductor (CMOS), exits the System Setup program, and reboots the system. When your system reboots, the BIOS configures the system according to the selections stored in CMOS.

Exit Without Saving Changes

Exits the System Setup program without saving any of the changes you have made.

Get Default Values

Loads the default values for each menu in the System Setup program.

Load Previous Values

Loads the values previously stored in CMOS for each menu.

Save Changes

Stores your changes in CMOS but does not exit the System Setup program.

Using the Password Features

CAUTION: The password features provide a basic level of security for the data on your system. However, they are not foolproof. If your data requires more security, it is your responsibility to obtain and use additional forms of protection, such as data encryption programs.

Using the Supervisor Password Feature

Your Dell system is shipped to you with the supervisor password set to Disabled, which allows you to enter the System Setup program and assign a password. When the Supervisor Password Is category is set to Enabled, the computer system prompts you for the supervisor password whenever you enter the System Setup program. If system

security is a concern, you should operate your system with supervisor password protection.

You can assign a supervisor password, as described in the next subsection, “Assigning a Supervisor Password,” whenever you use the System Setup program. Once a supervisor password is assigned, only those who know the password have full use of the System Setup program.

To delete or change an existing supervisor password, you must know the supervisor password (see “Deleting or Changing an Existing Supervisor Password” found later in this section).

NOTE: You can also assign, delete, or change a supervisor password through the EISA Configuration Utility. See “Assigning a Supervisor Password” and “Deleting or Changing an Existing Supervisor Password” in Chapter 5.

If you assign and then *forget* a supervisor password, you need your computer key to get inside the computer, where you can change a jumper setting to disable the supervisor password feature (see “Disabling a Forgotten Password” found later in this section). Note that you erase the *user password* at the same time.

NOTE: The system allows you three attempts to enter a password. After three failed attempts, the keyboard locks up and you must reboot the system before you can try entering a password again.

Assigning a Supervisor Password

A supervisor password can be assigned only when the Supervisor Password Is category is set to Disabled.

Press <Enter> to display a dialog box in which you can enter the password. You can use up to seven alphanumeric characters in a password, and the password is not case sensitive (meaning that there is no difference between uppercase and lowercase characters).

NOTE: The supervisor password can be the same as the user password. However, a user password cannot be set until a supervisor password has been set.

After you verify the password, the Supervisor Password Is setting changes to Enabled. The next time you attempt to enter the System Setup program, the system prompts you for the supervisor password.

Keep the following tips in mind when setting your password:

- You can use up to seven alphanumeric characters in your password (passwords are not case sensitive).
- As you press each character key (or the <Spacebar> for a blank space), a placeholder appears in the field.
- To erase a character when entering your password, press the <Backspace> key or the left-arrow key.

*NOTES: The password assignment operation recognizes keys by their location on the keyboard, without distinguishing between lowercase and uppercase characters. For example, if you have an **M** in your password, the system recognizes either **M** or **m** as correct.*

Certain key combinations are not valid. If you enter one of these combinations, a beep sounds.

To exit the field without assigning a supervisor password, press the up-arrow or down-arrow key to move the highlight to another field, or press the <Esc> key at any time before setting a new password.

Using Your Supervisor Password to Secure Your System

Each time you turn on your system, reboot the system, or press the reset button, the following prompt appears on the screen (if the Password On Boot category is set to Enabled).

Enter password:

After you enter the correct supervisor password and press <Enter>, your system boots and you can use the keyboard to operate your system as usual.

If a wrong or incomplete password is entered, the following message appears on the screen:

Warning, Invalid password.

Press <Enter> to continue

Enter the password again. If an incorrect or incomplete supervisor password is entered again, the same message appears on the screen.

The third time an incorrect or incomplete password is entered, the keyboard locks up and displays the following message:

SYSTEM DISABLED

You must reboot the system before you can attempt to enter a password again.

Operating With a Supervisor Password Enabled

If Supervisor Password Is is set to Enabled, you must enter the correct supervisor password before you can modify any System Setup categories (other than the Time, Date, Num Lock, and Speaker categories).

Deleting or Changing an Existing Supervisor Password

To disable the supervisor password, press <Enter> to display the Set Password dialog box, and then press <Enter> two more times.

When the Supervisor Password Is category displays Disabled, you can assign a supervisor password or operate the system with no password assigned.

To change an existing supervisor password, first enter the System Setup program and disable the current password. Then, with the Supervisor Password Is category set to Disabled, assign a new supervisor password as described in “Assigning a Supervisor Password” found earlier in this section.

Using the User Password Feature

Your Dell system is shipped to you with the user password feature set to Disabled. After you assign a user password, set the User Password Is category to Enabled, and set the Password On Boot category to Enabled, the computer system prompts you for the user password at system start-up. If system security is a concern, you should operate your system with user password protection.

You can assign a user password, as described in the next subsection, “Assigning a User Password,” whenever you use the System Setup program. Once you assign a user password, only those who know the password have full use of the system.

NOTE: You can also assign, delete, or change a user password through the EISA Configuration Utility. See “Assigning or Changing a User Password” and “Deleting an Existing User Password” in Chapter 5.

To disable the user password, press <Enter> to display the Set Password dialog box, and then press <Enter> two more times.

If you assign and then *forget* a user password, you must remove the cover of the computer (which may require unlocking the computer's keylock) and change a jumper setting to temporarily disable the user password feature (see "Disabling a Forgotten Password" found later in this section). Note that you erase the *supervisor password* at the same time.

CAUTION: If you leave your system running and unattended, anyone can access the data stored in your system even with a user password assigned. To protect your system while it is running, you must use additional forms of protection, such as screensaver software protected by a password.

CAUTION: With the password features disabled, your system operates as if it did not contain password features. If you leave your system running and unattended without having a system and/or supervisor password assigned or with the password features disabled, anyone can assign a system and/or supervisor password that will be unknown to you.

NOTE: The system allows you three attempts to enter a password. After three failed attempts, the keyboard locks up and you must reboot the system before you can try entering a password again.

Assigning a User Password

NOTE: You cannot assign a user password until a supervisor password has been set.

When in the Set User Password category, you can press <Enter> to display a dialog box in which you can enter a user password. You can use up to seven alphanumeric characters in a password, and the password is not case sensitive (meaning that there is no difference between uppercase and lowercase characters).

When a user password is set, the status shown in the User Password Is category is Enabled.

With no user password assigned and with a jumper plug installed on the password jumper (PASSWD) on the system board (its default setting), the status shown in the User Password category is set to Disabled.

Keep the following tips in mind when setting your password:

- You can use up to seven alphanumeric characters in your password (passwords are not case sensitive).
- As you press each character key (or the <Spacebar> for a blank space), a placeholder appears in the field.
- To erase a character when entering your password, press the <Backspace> key or the left-arrow key.

*NOTES: The password assignment operation recognizes keys by their location on the keyboard, without distinguishing between lowercase and uppercase characters. For example, if you have an **M** in your password, the system recognizes either **M** or **m** as correct.*

Certain key combinations are not valid. If you enter one of these combinations, a beep sounds.

To exit the field without assigning a user password, press the up-arrow or down-arrow key to move the highlight to another field, or press the <Esc> key at any time before setting a new password.

Using Your User Password to Secure Your System

Each time you turn on your system, reboot the system, or press the reset button, the following prompt appears on the screen:

Enter password:

After you enter the correct user password and press <Enter>, your system boots and you can use the keyboard to operate your system as usual.

If a wrong or incomplete password is entered, the following message appears on the screen:

Warning, Invalid password.

Press <Enter> to continue

Enter the password again. If an incorrect or incomplete user password is entered again, the same message appears on the screen.

The third time an incorrect or incomplete password is entered, the keyboard locks up and displays the following message:

SYSTEM DISABLED

You must reboot the system before you can attempt to enter a password again.

Deleting or Changing an Existing User Password

To disable the user password, press <Enter> to display the Set Password dialog box, and then press <Enter> two more times.

When the User Password Is category displays Disabled, you can assign a user password or operate the system with no password assigned.

To change an existing user password, first enter the System Setup program and disable the current password. Then, with the User Password Is category set to Disabled, assign a new user password as described in “Assigning a User Password” found earlier in this section.

Disabling a Forgotten Password

If you forget your user or supervisor password, you cannot operate your system or change settings in the System Setup program, respectively, until you open the computer chassis, change the password jumper setting to disable the passwords, and erase the existing passwords.

To disable a forgotten password, perform the following steps:

- 1. Remove the computer cover according to the instructions in “Removing the Computer Cover” in Chapter 6.**

<p>CAUTION: See “Protecting Against Electrostatic Discharge” in the safety instructions at the front of this guide.</p>
--

- 2. Refer to “Jumpers” and Table B-1 in Appendix B for jumper information, and to Figure B-1 for the location of the password jumper (labeled “PASSWD”) on the system board.**
- 3. Remove the jumper plug from the PASSWD jumper (the *disabled* setting).**
- 4. Replace the computer cover according to the instructions in “Replacing the Computer Cover” in Chapter 6, reconnect your computer to its power source, and turn it on.**

Booting your system with the PASSWD jumper removed erases the existing password(s).

NOTE: Before you assign a new system and/or supervisor password, you must reinstall the jumper plug on the PASSWD jumper.

- 5. Repeat step 1.**
- 6. Reinstall the jumper plug on the PASSWD jumper pins (the *enabled* setting).**
- 7. Repeat step 4.**
- 8. Assign a new system and/or supervisor password.**

To assign a new user password, see “Assigning a User Password” found earlier in this section. To assign a new supervisor password, see “Assigning a Supervisor Password” found earlier in this section.

Password Options

Table 4-2 lists several ways the supervisor and user password and the Password On Boot category can be used to provide security for your system.

Table 4-2. Password Options

Supervisor Password	User Password ¹	Password on Boot	Boot Prompt	Setup Prompt	Comments
Enabled	Disabled	Enabled	Yes	Yes ²	You are prompted for a password at boot and for access to System Setup. Supervisor password must be entered for system to boot. Supervisor password must be entered at setup prompt for full use ³ of System Setup.
Enabled	Disabled	Disabled	No	Yes ²	Your are not prompted for a password at boot. Supervisor password must be entered at setup prompt for full use ³ of System Setup.
Enabled	Enabled	N/A	Yes	Yes	You are prompted for a password at boot and for access to System Setup. If supervisor password is entered, you have full use of System Setup and access to the diskette drive. If user password is entered, you have partial ² use of System Setup and can access the diskette drive only if the Diskette Access category is set to User.
Disabled	N/A	N/A	No	No	You are not prompted for a password at boot or for access to System Setup. You can change any category in System Setup.

¹ The system always requests a password at boot if the user password is enabled.

² If you press <Esc> at the setup password prompt, you can access the System Setup program but can change only the categories described in note 3 below.

³ The user can change only the Date, Time, Num Lock, Speaker, and Set User Password categories unless the supervisor password is entered.

Responding to Error Messages

If an error message appears on your monitor screen while the system is booting, make a note of the message. Then, before entering the System Setup program, refer to Appendix F, “Beep Codes and System Messages,” for an explanation of the message and suggestions for correcting any errors. (An exception to this routine: It is normal to receive an error message the first time you boot your system after installing a memory upgrade. In that situation, you do not need to refer to Appendix F. Instead, follow the instructions in “Performing a Memory Upgrade” in Chapter 7.)

If you are given the option of pressing either <F1> to continue or <F2> to run the System Setup program, press the <F2> key.

Chapter 5

Using the EISA Configuration Utility

The EISA Configuration Utility is used to tell the system what expansion cards are installed and which expansion slots they occupy. With this information, the system automatically configures Extended Industry-Standard Architecture (EISA) cards and can tell you how to configure Industry-Standard Architecture (ISA) cards manually by setting jumpers or switches. Before your system was shipped from Dell, a technician used the EISA Configuration Utility to enter the correct information for the expansion cards initially installed in your computer.

The EISA Configuration Utility also monitors the resources required by any installed Peripheral Component Interconnect (PCI) expansion card. After installing or moving a PCI expansion card, you should run the EISA Configuration Utility to update the system's database of available system resources stored in nonvolatile random-access memory (NVRAM).

Configuring EISA, ISA, and PCI Expansion Cards

Whenever you add, remove, or reposition an EISA or ISA expansion card, use the EISA Configuration Utility to reconfigure your system. The utility reads the card's corresponding configuration file (.cfg file), which describes the card's characteristics and required system resources, and then uses this information to create a conflict-free configuration. (You can also use the EISA Configuration Utility to set certain system operating parameters known as *system board options*, as well as to correct the system configuration information.)

The EISA Configuration Utility is PCI aware and can also be used to configure PCI expansion cards. Configuration information for PCI expansion cards is contained

within the card, so no additional .cfg file is required. You should run the EISA Configuration Utility *after* installing or moving a PCI expansion card to keep the system's database of available resources accurate.

If the EISA Configuration Utility is not aware of an installed ISA or EISA expansion card, resource conflicts can arise. *For this reason, it is extremely important to enter information about ISA expansion cards, as well as EISA expansion cards, into the EISA Configuration Utility.* In addition, certain ISA graphics adapter cards and multiport serial cards require some memory or caching reconfiguration provided by the EISA Configuration Utility.

NOTE: The System Setup program allows you to change the interrupt requests (IRQs) for the serial and parallel ports to maximize system performance. See "Advanced Menu Categories" in Chapter 4 for instructions.

System Board Options

In addition to configuring expansion cards, you can use the EISA Configuration Utility to change certain system board options, as described in "Step 3: View or Edit Details" found later in this chapter.

Many of the system board options in the EISA Configuration Utility correspond to categories in the System Setup program. Although the two utilities are separate, the EISA Configuration Utility automatically forwards changes to, and reads changes from, the System Setup program. Thus, for configuration options that appear in both utilities, you can set the options through either utility.

NOTE: In most cases, your system operates according to the most recent changes, regardless of which utility you use to make the changes. However, some software written

for EISA systems may require that the change be saved to the EISA configuration memory to operate properly.

How to Run the EISA Configuration Utility

The EISA Configuration Utility is included on the *Dell Server Assistant* CD shipped with your system. This CD includes an EISA Configuration Utility directory that contains the main program plus a directory of **.cfg** files for many—but not all—ISA expansion cards.

You can run the EISA Configuration Utility directly from the CD or from a diskette that you create using the CD's main menu. Dell recommends that you run the EISA Configuration Utility from a diskette because it is not compatible with all operating systems. Also, using a diskette to run the utility allows you to copy any system configuration changes to the diskette for safekeeping. See Chapter 2, "Using the Dell Server Assistant CD," for instructions on creating an EISA Configuration Utility diskette.

When you buy an EISA expansion card, you receive a configuration diskette containing the card's configuration file with the filename extension **.cfg**. Copy this **.cfg** file to your EISA Configuration Utility diskette. The EISA Configuration Utility uses the information in this file to configure the new card.

When you buy an ISA expansion card, copy the appropriate configuration file (contained in the **.cfg** directory on the diskette) to your EISA Configuration Utility diskette. If the **.cfg** directory does not contain a configuration file for your ISA expansion card, use the generic ISA card configuration file, which is included in the **.cfg** directory on the CD. Instructions for using the generic **.cfg** file are included in "Adding an Expansion Card" found later in this chapter.

PCI expansion cards do not require a configuration file. The PCI configuration utility in ROM automatically uses the information maintained by the EISA to assign resources for PCI expansion cards.

CAUTION: You *must* use the EISA Configuration Utility when you add an EISA or ISA expansion card to your computer. For an ISA card, use the specific configuration file for your expansion card, if one is available, rather than the generic ISA card configuration file. The generic ISA card configuration file cannot be used to identify potential resource conflicts or proper jumper and switch settings.

When to Run the EISA Configuration Utility

Whenever you add, remove, or reposition an ISA or EISA expansion card, you must run the EISA Configuration Utility to specify which expansion slot the card is installed in and to ensure that no two cards attempt to use the same resources (such as IRQ lines).

When you use the utility with ISA expansion cards, run the program *before* adding, removing, or repositioning any cards. The EISA Configuration Utility can identify and resolve any resource conflicts, as well as indicate the proper jumper and switch settings for each expansion card to avoid such conflicts. Running the program first helps you determine how to configure the expansion card before it is installed in your computer.

When you use the utility with EISA expansion cards, you should normally run the program *after* adding, removing, or repositioning the card. However, some cards have ROM or a device driver that examines the configuration information stored in NVRAM; these cards require that you run the program *before* the card is installed. Each configuration file for an EISA expansion card has an identification number the utility reads before configuring the card. EISA expansion cards have no jumpers or switches that must be set before the card is installed.

When you use the utility with PCI expansion cards, you should run the program *after* adding a PCI expansion card so the EISA Configuration Utility will have a current record of assigned resources.

NOTE: If your system detects a card configuration problem during operation, you receive a warning message directing you to run the EISA Configuration Utility to correct the problem.

Making Selections in the EISA Configuration Utility

The EISA Configuration Utility uses menus to guide you through the configuration process. The menus and their options are accessed through keyboard commands.

To make a menu selection, use the up- or down-arrow key to highlight the desired option, and then press <Enter>. In the Help menu or Advanced menu, you can also select an option by pressing the key that corresponds to the highlighted letter in the selection list.

To scroll up or down a screen, press the <Page Up> or <Page Down> key, respectively.

Using Online Instructions

The EISA Configuration Utility has online instructions for each of its procedures. If you need help at any time, press <F1> to see a help screen that offers more details about the task you are doing.

Starting the EISA Configuration Utility

NOTES: Your system's default hardware configuration allows updating of the EISA configuration information. However, if the EISA jumper on the system board is installed, the EISA configuration information cannot be updated until the jumper plug is removed.

If you have reason to think the EISA jumper setting has been changed, check the jumper before attempting to make an EISA configuration change. For instructions on removing and replacing the computer cover, see "Removing the Computer Cover" and "Replacing the Computer Cover" in Chapter 6. For information on the EISA jumper location and settings, see Figure B-1 and Table B-1, respectively, in Appendix B, "Hardware Configuration Features."

If you are running the EISA Configuration Utility from your hard-disk drive, remove any TSR programs from memory before starting the utility. These programs take up space in system memory even when they are not running, thus reducing the amount of memory available to the EISA Configuration Utility. See the documentation

that accompanied these programs for instructions on removing them from memory.

If you start the utility and there is not enough memory to run it, a message is displayed. If you receive such a message, run the utility from a diskette.

Follow these steps the first time you use the EISA Configuration Utility. Later, if a card is added, removed, or repositioned, you must follow the procedure described in "Step 2: Add or Remove Boards" found later in this chapter.

1. **To run the program from a diskette, insert into drive A the EISA Configuration Utility diskette that you created from the CD. Then either turn on your computer or reboot it by pressing the <Ctrl><Alt> key combination or the reset button.**

To run the program from your hard-disk drive, switch to the c:\eisacfg subdirectory, type sd at the operating system prompt, and press <Enter>.

To run the program from the Dell Server Assistant CD, restart the system from the CD. Select Run EISA Configuration Utility from the CD's main menu.

To access the advanced options (described in "Advanced Menu" found later in this chapter), press <Ctrl><a> at the Welcome screen.

You can run the EISA Configuration Utility in modeling mode by typing sd /n at the operating system prompt and pressing <Enter>.

NOTE: To use modeling mode, you must run the EISA Configuration Utility from your hard-disk drive.

Modeling mode lets you set up configuration parameters for a system different from the one you are using and allows you to save a configuration to a file. Modeling mode is useful if you need to configure many systems identically; instead of using the EISA Configuration Utility to configure each system, you can transfer the configuration file to a diskette and load it onto each system. See "Modeling Mode" found later in this chapter for more information.

Press <Esc> to return to the Welcome screen.

2. When the Welcome screen appears, read the information on the screen and press <Enter>.

The Main Menu appears as follows:

Main Menu

Learn about configuring your computer
Configure computer
Set date
Set time
Maintain system configuration diskette
Exit from this utility

The first option in the menu is already highlighted.

3. Press <Enter> to read the online overview of the EISA Configuration Utility.

After reading the online overview, you are ready to use the program to configure your computer for any EISA expansion cards currently installed or any ISA expansion cards that will be installed in your computer's expansion slots.

Main Menu

The following five sections describe each of the menu options in the Main Menu and the submenus for those options.

Learn About Configuring Your Computer

The Learn About Configuring Your Computer option presents an overview of the configuration process. As you finish reading a screen, press <Enter> to view the next screen. Press <F10> to return to the Main Menu.

Configure Computer

The Configure Computer option takes you through the configuration process step by step. Use this option the first time you configure your system and every time you change your configuration through the EISA Configuration Utility.

When you select Configure Computer, the following menu appears on the screen:

Steps in configuring your computer
Step 1: Important EISA configuration information
Step 2: Add or remove boards
Step 3: View or edit details
Step 4: Examine switches or print report
Step 5: Save and exit

NOTES: If you enabled the supervisor password through the System Setup program or through the EISA Configuration Utility, the EISA utility prompts you for the supervisor password when you select Configure Computer. If you enter the supervisor password correctly, the utility displays the Steps in Configuring Your Computer menu and allows you to make changes to the EISA System Board Options screen when you select Step 3: View or Edit Details from the menu.

If you enter a user password instead of a supervisor password, you will get the following message:

This is a user password. In step 3 of the next screen you may view but not edit details.

If you enter the supervisor password incorrectly three times, the EISA Configuration Utility displays the following message:

This is an incorrect password. In step 3 of the next screen you may view but not edit details.

The following subsections describe each of the options (steps) shown in the Steps in Configuring Your Computer menu.

Step 1: Important EISA Configuration Information

The Step 1: Important EISA Configuration Information option uses seven information screens to explain the EISA configuration process and how it differs from the ISA configuration process. After reading the first screen, press <Enter> to see the next one. When you have finished reading all seven screens, press <Esc> to return to the Steps in Configuring Your Computer menu.

To review the information screens at any time while you are in the EISA Configuration Utility, press <F1> and select EISA Configuration from the Help menu.

Step 2: Add or Remove Boards

When you select the Step 2: Add or Remove Boards option, the EISA Configuration Utility lists all the expansion slots in your computer. (You may have to press <Page Down> to view the entire list.)

If you copied a card's configuration file to your EISA Configuration Utility diskette or to the EISA sub-directory on your hard-disk drive, the card name appears in the expansion slot in which the card is installed.

The first time you run the EISA Configuration Utility, select Step 2: Add or Remove Boards to verify that the system has detected and acknowledged any expansion cards Dell installed when you purchased your system. Use this option whenever you add or remove an expansion card and every time you reposition a card from one expansion slot to another in your computer.

To add, reposition, or remove an expansion card, highlight the corresponding expansion slot and press <Ins> to add, <F7> to reposition, or to remove the card. The utility guides you through the steps required to add, remove, or reposition a card's configuration file within the EISA Configuration Utility. If there are no resource conflicts, the system configuration information is saved to a system configuration (.sci) file when you exit the utility.

Adding an Expansion Card

Before you add an ISA or EISA expansion card, you must add the card's .cfg file to the utility. Configuration information for PCI expansion cards is contained within the card, so no .cfg file is required.

*NOTE: Use the following procedure **before** an ISA expansion card is installed but **after** an EISA expansion card is installed. See "When to Run the EISA Configuration Utility" found earlier in this chapter for more detailed information.*

1. **Start the EISA Configuration Utility as described in "Starting the EISA Configuration Utility" found earlier in this chapter.**

2. **At the Main Menu, select Configure Computer.**

If the EISA Configuration Utility prompts you for a supervisor password, type the password and press <Enter>.

3. **At the Steps in Configuring Your Computer menu, select Step 2: Add or Remove Boards.**

A list of expansion slots and the cards in them appears on the screen.

4. **Highlight the expansion slot in which the card will be installed, press <Ins>, and follow the online instructions.**

If the utility asks for the option configuration diskette, insert the diskette that accompanied your expansion card.

If the utility asks for the system configuration diskette, insert your EISA Configuration Utility diskette.

If the utility asks for the .cfg file library diskette, insert the diskette of .cfg files.

5. **From the list of configuration files listed by the utility, choose the one that corresponds to the card you want to add.**

The utility asks you to confirm your choice, and then it prompts you to select the expansion slot in which the card will be installed.

If you are adding an ISA expansion card, insert your .cfg diskette to find the .cfg file for that card. If the .cfg file for the expansion card you are installing is not on the diskette, select Generic ISA Board from the list of configuration files.

NOTE: Alternatively, if you know the resources used by the expansion card, you can press <F7> and bring up a menu that lets you create the .cfg file.

For all ISA expansion cards, use the Step 4: Examine Switches or Print Report option (under the Steps in Configuring Your Computer menu) to check the switch and jumper settings on the new card. Configure the new card as indicated before it is installed in your computer.

6. **Press <F10>, select Step 5: Save and Exit, and follow the online instructions to save the current system configuration information.**

Remember to save a printout or written copy of your new configuration. The utility may prompt you to check the jumper and switch settings on the new card. Follow the online instructions to see an illustration of the new card's settings.

Repositioning an Expansion Card

Use the following procedure *before* an ISA expansion card is repositioned but *after* an EISA or PCI expansion card is repositioned. See “When to Run the EISA Configuration Utility” found earlier in this chapter for more detailed information.

1. **Start the EISA Configuration Utility as described in “Starting the EISA Configuration Utility” found earlier in this chapter.**
2. **At the Main Menu, select Configure Computer.**
If the EISA Configuration Utility prompts you for a supervisor password, type the password and press <Enter>.
3. **At the Steps in Configuring Your Computer menu, select Step 2: Add or Remove Boards.**
A list of expansion slots and the cards in them appears on the screen.
4. **Highlight the name of the card you want to reposition, press <F7>, and follow the online instructions.**
5. **Press <F10>, select Step 5: Save and Exit, and follow the online instructions to save the current system configuration information.**

Remember to save a printout or written copy of the new information.

Removing an Expansion Card

Use the following procedure *before* an ISA expansion card is removed but *after* an EISA or PCI expansion card is removed. See “When to Run the EISA Configuration

Utility” found earlier in this chapter for more detailed information.

1. **Start the EISA Configuration Utility as described in “Starting the EISA Configuration Utility” found earlier in this chapter.**
2. **At the Main Menu, select Configure Computer.**
If the EISA Configuration Utility prompts you for a supervisor password, type the password and press <Enter>.
3. **At the Steps in Configuring Your Computer menu, select Step 2: Add or Remove Boards.**
A list of expansion slots and the cards in them appears on the screen.
4. **Highlight the name of the card you want to remove, press , and follow the online instructions.**
5. **Press <F10>, select Step 5: Save and Exit, and follow the online instructions to save the current system configuration information.**

Remember to save a printout or written copy of the new information.

If there are no resource conflicts, the configuration information is saved to a system configuration (.sci) file when you exit the utility. If there is a resource conflict, you must resolve it before completing the configuration. For more information, see “Resolving Resource Conflicts” found later in this chapter.

Step 3: View or Edit Details

The EISA Configuration Utility lets you set a variety of system options through the .sci file. Through this file, you can notify the system of changes to your hardware and memory configuration, set and change your passwords, manage input/output (I/O) ports, and set other system operating parameters.

Some of the categories do not offer options, but reflect installed hardware detected by the system. These items are displayed for your information only; you cannot change them through the utility.

NOTES: Most system board options available through the EISA Configuration Utility are also available through the System Setup program as described in Chapter 4, "Using the System Setup Program." Although the EISA Configuration Utility is separate from the System Setup program, the EISA utility forwards changes to, and reads changes from, corresponding categories in the System Setup program.

However, when the EISA Configuration Utility reads a change from the System Setup program, that change is not stored in EISA configuration memory until you start the EISA Configuration Utility, let it read the changes from the System Setup program, and then save the configuration. To avoid possible resource conflicts, start the EISA Configuration Utility and save the configuration after making System Setup program changes that allocate system resources. In addition, some software written for EISA systems may require that the changes be saved to the EISA configuration memory for proper operation.

Display the list of system board options as follows:

- 1. Start the EISA Configuration Utility as described in "Starting the EISA Configuration Utility" found earlier in this chapter.**
- 2. At the Main Menu, select Configure Computer.**
- 3. If the EISA Configuration Utility prompts you for a supervisor password, type the password and press <Enter>.**
- 4. At the Steps in Configuring Your Computer menu, select Step 3: View or Edit Details.**

A list of system board options appears on the screen. Figure 5-1 shows settings typical for your system.

NOTES: If the EISA Configuration Utility prompted you for a supervisor password in step 3 but you were unable to correctly specify it, you can only view the EISA System Board Options screen. You cannot change any of the values or settings.

Whenever you add an expansion card to the computer, its presence is reflected by changes to the EISA System Board Options screen.

To select a category on the list of system board options, press the up- or down-arrow key to highlight the category and press <Enter>. A pop-up menu appears, listing the options for that category. To select an option, press the

up- or down-arrow key to highlight the option and press <Enter>.

NOTES: Several system board categories allow you to edit such resources as memory address, I/O ports, IRQs, and direct memory access (DMA) channels. It may be necessary to edit these resources to resolve a configuration conflict. To view the resource screen for any category, highlight the option and press <F6>.

The edit resources feature is intended for users who are technically knowledgeable. Do not change resource settings from their defaults if you do not understand how such a change will affect system performance.

While in the Step 3: View or Edit Details menu, you can press <F7> to enter the Advanced menu. See "Advanced Menu" found later in this chapter for more information.

When you have finished making changes, save the new system configuration information and exit the utility as follows:

- 1. Press <F10>, and select Step 5: Save and Exit from the Steps in Configuring Your Computer menu.**
- 2. Select Save the Configuration and Restart the Computer from the menu that appears.**

The following system board options are available on the EISA System Board Options screen (see Figure 5-1). Some of the options are the same as options on the System Setup screens. The options on the EISA System Board Options screen work the same as similarly named categories in the System Setup program. For details on using the System Setup program options, see the corresponding subsections in Chapter 4, "Using the System Setup Program."

Memory Options

- DIMM Memory
- Extended Memory
- Base Memory

CPU Options

- Cache (same as Level 2 Cache in the System Setup program)
- MP Specification

CPU Information

- Processor 1 and Processor 2
- CPU Speed
- Level 2 Cache Size

System Information

- BIOS Revision
- Service Tag
- Asset Tag

Boot Options

- Post Errors
- Keyboard Errors
- Num Lock
- Reset Button
- Speaker Enable
- Boot Sequence
- PCI Bus SCSI
- PCI Scan Sequence

Password Options

- Password on Boot
- Supervisor Password
- User Password

Mouse Options

- Integrated Mouse

Video Options

- Fast Video BIOS

Diskette Options

- Integrated Diskette Controller
- Drive A
- Drive B
- Drive Access

The Drive A and Drive B categories work the same as Diskette Drive A and Diskette Drive B in the System Setup program. The Drive Access category allows access to the diskette drive to be controlled by the supervisor or user password to prevent unauthorized access.

Integrated Serial Interface

- Serial Port 1
- Serial Port 2

Integrated Parallel Interface

- Parallel Port
- Parallel Port Mode (same as Parallel Mode in the System Setup program)

Embedded PCI SCSI Controller

- PCI Function 1

Embedded PCI VGA Controller

- PCI Function 1
- Standard VGA Resources

NOTE: You can clear the system configuration parameters from NVRAM by placing a jumper on the EISA jumper pins and then booting the system with the jumper in place. See Table B-1 in Appendix B for more information.

System - Dell PowerEdge 2200	
Memory Options	
DIMM Memory	64 MB
Extended Memory	65472 KB
Base Memory	640 KB
CPU Options	
Cache	Enabled
MP Specification	1.4
CPU Information	
Processor 1	Installed
Processor 2	Not installed
CPU Speed	233 MHz
Level 2 Cache Size	512 MB
System Information	
BIOS Revision	xxxxx
Service Tag	AB12Z
Asset Tag	123456789A
Boot Options	
POST Errors	Do Not Ignore
Keyboard Errors	Do Not Ignore
Num Lock	Enabled
Reset Button	Enabled
Speaker Enable	Enabled
Boot Sequence	A: then C:
PCI Bus SCSI	Enabled
PCI Scan Sequence	Embedded devices first
Password Options	
Password on Boot	Disabled
Supervisor Password	Not Enabled
User Password	Not Enabled
Mouse Options	
Integrated Mouse	Enabled
Video Options	
Fast Video BIOS	Enabled and cached
Diskette Options	
Integrated Diskette Controller	Enabled
Drive A	3.5 Inch, 1.44 MB
Drive B	Not Installed
Drive Access	User
Integrated Serial Interface	
Serial Port 1	Port 3F8, IRQ4
Serial Port 2	Port 2E8, IRQ3
Integrated Parallel Interface	
Parallel Port	Port 378, IRQ7
Parallel Port Mode	Output only
Embedded PCI SCSI Controller	
PCI Function 1	Enabled
Embedded PCI VGA Controller	
PCI Function 1	Enabled
Standard VGA Resources	

Figure 5-1. EISA System Board Options Screen (Example)

Step 4: Examine Switches or Print Report

The Step 4: Examine Switches or Print Report option lists the required switch and jumper settings for each expansion card in your computer. To view the settings, highlight the card and press <Enter>. For ISA expansion cards, it is important to compare the jumper and switch settings listed on the screen to the actual settings on the card.

Press <F7> to make a copy of or print the settings. If your computer is attached to a printer, you can print out the information or copy it to a file.

Step 5: Save and Exit

The Step 5: Save and Exit option allows you to save or cancel the configuration changes you have made. When you select this option, follow the directions on the menu that displays.

If you save your changes, the utility saves the new configuration in your system's NVRAM and in a file on your EISA Configuration Utility diskette. Then, the utility automatically reboots your system.

If you cancel your changes, you can remain in the utility to make other changes or exit the utility without saving any changes.

Set Date and Set Time

The Set Date and Set Time options reset the date and time maintained by your computer's real-time clock (RTC), which uses NVRAM to keep the information current even when the system is turned off. You can also reset the date and time through the System Setup program as described in Chapter 4, "Using the System Setup Program."

NOTES: If your system is connected to a network, the Date and Time categories may reflect the time maintained by the network server, depending upon how the network is configured. In this case, changing the Date and Time categories on your system has no effect.

Unless the EISA Configuration Utility is installed on your hard-disk drive, it is quicker to reset the date and time through the System Setup program.

Maintain System Configuration Diskette

Using the Maintain System Configuration Diskette option, you can create a backup copy of the **.sci** file or use a previously saved **.sci** file to reconfigure your system or to identically configure many other systems. You can also copy **.cfg** files and delete **.sci** and **.cfg** files from your EISA Configuration Utility diskette, your diskette of **.cfg** files, or the configuration diskette(s) for any hardware option.

Exit From This Utility

The Exit From This Utility option allows you to exit from the EISA Configuration Utility and reboot your computer system.

Advanced Menu

The Advanced menu lets you lock or unlock cards in a configuration, view detailed information about the system, and maintain **.sci** files.

To see the Advanced menu, press <F7> while in the Step 3: View or Edit Details menu. The following menu appears:

Advanced menu

Lock/unlock boards

View additional system information menu

Set verification mode menu

Maintain SCI files menu

Highlight the menu category you want, and press <Enter>. Then follow the online instructions.

The following subsections describe each category.

Lock/Unlock Boards

When you *lock* an expansion card, the EISA Configuration Utility cannot change the resources allocated to that card. *Unlocking* the card allows the system to change the resources automatically as new cards are added. The default setting for the Lock/Unlock Boards category is Unlocked. Dell recommends that you keep your cards unlocked so that the EISA Configuration Utility can do its job properly.

View Additional System Information Menu

The EISA Configuration Utility contains detailed information about the system board, the EISA and ISA expansion cards installed in your computer, and the used and available resources. The options for the View Additional System Information Menu category are:

- Board Specifications
- System Specifications
- Used Resources
- Available Resources

The Used Resources and Available Resources options contain detailed information about resources such as IRQs, DMA channels, and I/O ports, which may be useful if you need to resolve a resource conflict.

Set Verification Mode Menu

The settings for the Set Verification Mode Menu category are Automatic (the default) and Manual. When this category is set to Automatic, the EISA Configuration Utility automatically checks for resource conflicts and tries to resolve them. Unless you are technically knowledgeable, leave this category set to Automatic.

Maintain SCI Files Menu

Each time you use the EISA Configuration Utility to configure your system, the system configuration information is saved in a **.sci** file and in system memory. You should save the system configuration information to a backup file that can be used to restore the information if the **.sci** file is damaged or lost. The options for the Maintain SCI Files Menu category are Open (the default) and Save As.

The Open option creates a backup file that overwrites the existing configuration. The Save As option allows you to select the filename under which you want the **.sci** file saved.

Resolving Resource Conflicts

The EISA Configuration Utility automatically resolves resource conflicts between two EISA expansion cards. It is extremely unusual for the EISA Configuration Utility

to fail in resolving a resource conflict between two EISA expansion cards. If the EISA Configuration Utility fails to resolve the conflict, see the chapter titled “Getting Help” in your *Diagnostics and Troubleshooting Guide* for information on obtaining technical assistance.

However, resource conflicts between ISA expansion cards are routine. If the Set Verification Mode menu category is set to Automatic, the EISA Configuration Utility tries to resolve the conflict. If the utility cannot resolve the conflict, the card you just installed is deactivated and the following message is displayed:

Caution

The last board added caused an un-resolvable conflict in your computer's configuration. This board has a 'Deactivated' status. You must remove this board or the one(s) it is in conflict with in order to save a correct configuration.

If the caution message appears, press <Enter> to display a list of all cards installed in your computer. The deactivated card is enclosed by < > symbols.

You can remove the card(s) with which it is in conflict, or change the resources on one or more cards.

If you want to remove the card, press and follow the online instructions. Remove the card from your computer when the utility prompts you to do so. (For instructions, see “Removing an Expansion Card” in Chapter 7.)

If you remove the card(s) with which the new card is in conflict, or if you want to change the resources of one or more cards, use the procedure described in the next subsection.

NOTE: Locked cards may cause resource conflicts.

To unlock a card, use the following procedure:

1. **Press <F7> in the Step 3: View or Edit Details menu (from the Steps in Configuring Your Computer menu).**
2. **Select Lock/Unlock Boards and press <Enter>.**
3. **Select the card(s) you want to unlock, and press <Enter>.**
4. **Press <F10> to exit the Advanced menu.**

Removing a Card That Conflicts With the Card You Just Installed

If there is a resource conflict between two ISA expansion cards and you want to remove the card that conflicts with the one you just installed, use the following procedure:

1. **From the Steps in Configuring Your Computer menu, select Step 2: Add or Remove Boards and press <Enter>.**

From the list of expansion slots and cards, select the card in conflict with the one installed, and press . When the utility asks you to confirm your command, press <Enter>. Then press <Esc> to return to the Steps in Configuring Your Computer menu.

2. **Select Step 5: Save and Exit, and press <Enter>.**
3. **Select Save the Configuration and Restart the Computer, and press <Enter>.**

The system reboots with the new system configuration information.

4. **If you deleted an expansion-card configuration file from the previously saved system configuration information, remove the card from your computer.**

For instructions, see “Removing an Expansion Card” in Chapter 7.

change will affect system performance. Some of these categories may not apply to your system.

NOTE: To access the advanced options in modeling mode, type `sd /n /a` at the operating system prompt and press <Enter>. (To use modeling mode, you must run the EISA Configuration Utility from your hard-disk drive.)

ISA Cycle Wait Control

The 8 Bit I/O ISA Cycle Wait Control and 16 Bit I/O ISA Cycle Wait Control options set the minimum time between back-to-back I/O cycles for 8-bit and 16-bit ISA expansion cards, respectively. The default setting is 500 nanoseconds (ns).

Fail-Safe Timer NMI

When enabled, the Fail-Safe Timer NMI option allows the generation of a fail-safe timer nonmaskable interrupt (NMI). The default setting is Disabled.

Bus-Master Timeout NMI

When enabled, the Bus-Master Timeout NMI option allows the generation of a bus-master time-out NMI. The default setting is Disabled.

Software Generated NMI

When enabled, the Software Generated NMI option allows the generation of a software NMI. The default setting is Disabled.

Modeling Mode

Modeling mode lets you create alternate .sci files to accommodate different hardware configurations. For example, if you regularly change the expansion cards or their arrangement in your computer, you can create and save a separate system configuration file for each configuration and load that file after changing the cards rather than having to create a new configuration file every time you change your configuration.

NOTE: To use modeling mode, you must run the EISA Configuration Utility from the hard-disk drive.

System Board Options Screen

The following categories appear on the EISA System Board Options screen (see Figure 5-1) only if you press <Ctrl><a> at the Welcome screen when you start the EISA Configuration Utility:

- 8 Bit I/O ISA Cycle Wait Control
- 16 Bit I/O ISA Cycle Wait Control
- Fail-Safe Timer NMI
- Bus-Master Timeout NMI
- Software Generated NMI

These advanced options are intended for users who are technically knowledgeable. Do not change these options from their defaults if you do not understand how such a

To use the EISA Configuration Utility in modeling mode, start the utility from your hard-disk drive by typing `sd /n` at the operating system prompt and pressing <Enter>. (To use the advanced options in modeling mode, type `sd /n /a` at the operating system prompt and press <Enter>.)

A dialog box appears with two options—Open As. . . (to load an existing system configuration file) and New (to create a new file). Highlight the option you want, and press <Enter>. The screen shows a list of Dell EISA systems. Choose the system you want to configure, and press <Enter>. At this point, you can modify or create a configuration file just as you would with the Configure Computer option.

Modeling mode also provides access to advanced system board and expansion-card features, such as enabling or disabling NMIs (see “Advanced Menu” found earlier in this chapter). Ordinarily, you do not need to adjust these features unless a Dell service technician instructs you to do so.

When you finish modifying or creating a system configuration file in modeling mode, select Step 5: Save and Exit from the Steps in Configuring Your Computer menu. A dialog box appears, offering two choices: to save the configuration file and restart the computer or to discard the configuration file and return to the Main Menu. If you choose to save the configuration file, you are prompted to type a filename for the new configuration file. Then you are prompted to type a description of the configuration file, which is stored with the configuration file.

Using the Password Features

CAUTION: The password features provide a basic level of security for the data on your system. However, they are not foolproof. If your data requires more security, it is your responsibility to obtain and use additional forms of protection, such as data encryption programs.

Your Dell system is shipped to you with the supervisor and user password features ready to use but without passwords assigned. If system security is a concern, you should operate your system with password protection.

You can assign a supervisor and/or user password through the EISA Configuration Utility (as described later in “Assigning a User Password” or “Assigning a Supervisor Password”) or through the System Setup program (as described in Chapter 4, “Using the System Setup Program”). Once you assign a supervisor and/or user password, only those who know the password(s) have full use of the system.

NOTE: You can also use the System Setup program to assign, change, or delete a user or supervisor password. See the appropriate sections in Chapter 4, “Using the System Setup Program,” for more information.

How Password Security Works

When a *supervisor* password is assigned and the Password On Boot category is set to Enabled, the system prompts you for the supervisor password every time you start or reboot your computer. After a supervisor password is assigned, the EISA Configuration Utility prompts you for the supervisor password if you select Configure Computer from the Main Menu. You must enter a supervisor password to be able to change any of the system configuration parameters. Entering a *user* password allows you to view, but not change any of the system configuration parameters.

To delete or change an existing supervisor or user password, you must know the supervisor password. See “Deleting an Existing User Password” or “Deleting an Existing Supervisor Password” found later in this section for more information.

NOTE: A user password can only be assigned after a supervisor password has been assigned.

If you assign and then *forget* a password, you must remove the cover of the computer (which may require unlocking the computer’s keylock) and change a jumper setting to temporarily disable the password features (see “Disabling a Forgotten Password” found later in this section).

CAUTION: If you leave your system running and unattended, anyone can access the data stored in your system even with a password assigned. To protect your system while it is running, you must use additional forms of protection, such as screen-saver software protected by a password.

CAUTION: With the password features disabled, your system operates as if it did not contain password features. If you leave your system running and unattended without having a supervisor and/or user password assigned or with the password features disabled, anyone can assign a supervisor and/or user password that will be unknown to you.

Assigning or Changing a Supervisor Password

Your system arrives with the Supervisor Password category set to Not Enabled. Use the following procedure to assign or change a supervisor password.

NOTE: To quit the following procedure without assigning or changing a password, press the <Esc> key at any time.

1. **Start the EISA Configuration Utility as described in “Starting the EISA Configuration Utility” found earlier in this chapter.**

2. **At the Main Menu, select Configure Computer.**

The system prompts you for a supervisor password if one has been assigned. If prompted, type the password and press <Enter>.

3. **At the Steps in Configuring Your Computer menu, select Step 3: View or Edit Details.**

The current status of the system board options appears on the screen.

NOTE: If the Supervisor Password category indicates Disabled by Jumper, you must install the password jumper before you can assign a supervisor password. See “Disabling a Forgotten Password” found later in this section for instructions on how to access the password jumper.

4. **Select the Supervisor Password category.**

A dialog box with an Enter supervisor password prompt and an empty seven-character field appears on the screen.

5. **Type your new supervisor password.**

NOTE: The supervisor password can be the same as the user password.

You can use up to seven characters; character keys or blank spaces are acceptable.

To erase a character in your password, press the <Backspace> key.

NOTES: The supervisor password feature recognizes keys without distinguishing between shifted and unshifted characters or uppercase and lowercase letters. For example, if you have an **M** in your password, the system recognizes either **M** or **m** as correct.

Certain key combinations are not valid. If you enter one of these combinations, the computer’s speaker beeps.

6. **Press <Enter>.**

A new dialog box with a Verify supervisor password prompt and an empty seven-character field appears on the screen.

7. **To confirm your supervisor password, type it again and press <Enter>.**

The Supervisor Password category indicates Enabled. Your supervisor password is now set, but it does not become operational until you save the configuration and exit the utility.

Deleting an Existing Supervisor Password

To delete an existing supervisor password, perform the following steps:

NOTE: Deleting the supervisor password automatically deletes the user password if one has been assigned.

1. **Start the EISA Configuration Utility as described in “Starting the EISA Configuration Utility” found earlier in this chapter.**

2. **At the Main Menu, select Configure Computer.**

The system prompts you for a supervisor password. Type the password and press <Enter>.

3. **At the Steps in Configuring Your Computer menu, select Step 3: View or Edit Details.**

4. **Select the Supervisor Password category, and press <Enter>.**

A dialog box with an Enter supervisor password prompt and an empty seven-character field appears on the screen.

5. Press <Enter>.

A new dialog box with a `Verify supervisor password` prompt and an empty seven-character field appears on the screen.

6. Press <Enter>.

You are returned to the Main Menu, where the Supervisor Password category now indicates Not Enabled.

Assigning or Changing a User Password

Your system arrives with the User Password category set to Not Enabled. Use the following procedure to assign or change a user password.

NOTE: To quit the following procedure without assigning or changing a password, press the <Esc> key at any time.

1. Start the EISA Configuration Utility as described in “Starting the EISA Configuration Utility” found earlier in this chapter.

2. At the Main Menu, select Configure Computer.

The system prompts you for a supervisor password if one has been assigned. If prompted, type the password and press <Enter>.

NOTE: If a supervisor password has not been assigned, you must assign one before you can assign a user password.

3. At the Steps in Configuring Your Computer menu, select Step 3: View or Edit Details.

The current status of the system board options appears on the screen.

4. Select the User Password category.

A dialog box with an `Enter user password` prompt and an empty seven-character field appears on the screen.

5. Type your new user password.

NOTE: The user password can be the same as the supervisor password.

You can use up to seven characters; character keys or blank spaces are acceptable.

To erase a character in your password, press the <Backspace> key.

*NOTES: The user password feature recognizes keys without distinguishing between shifted and unshifted characters or uppercase and lowercase letters. For example, if you have an **M** in your password, the system recognizes either **M** or **m** as correct.*

Certain key combinations are not valid. If you enter one of these combinations, the computer’s speaker beeps.

6. Press <Enter>.

A new dialog box with a `Verify user password` prompt and an empty seven-character field appears on the screen.

7. To confirm your user password, type it again and press <Enter>.

The User Password category indicates Enabled. Your user password is now set, but it does not become operational until you save the configuration and exit the utility.

Deleting an Existing User Password

To delete an existing user password, perform the following steps:

1. Start the EISA Configuration Utility as described in “Starting the EISA Configuration Utility” found earlier in this chapter.

2. At the Main Menu, select Configure Computer.

When the system prompts you for a supervisor password, type the password and press <Enter>.

3. At the Steps in Configuring Your Computer menu, select Step 3: View or Edit Details.

4. Select the User Password category, and press <Enter>.

A dialog box with an `Enter user password` prompt and an empty seven-character field appears on the screen.

5. Press <Enter>.

A new dialog box with a `Verify user password` prompt and an empty seven-character field appears on the screen.

6. Press <Enter>.

You are returned to the Main Menu, where the User Password category now indicates Not Enabled.

Disabling a Forgotten Password

If you forget your user or supervisor password, you cannot operate your system or change settings in the System Setup program, respectively, until you open the computer chassis, change the password jumper setting to disable the passwords, and erase the existing passwords.

To disable a forgotten password, perform the following steps:

- 1. Remove the computer cover according to the instructions in “Removing the Computer Cover” in Chapter 6.**

<p>CAUTION: See “Protecting Against Electrostatic Discharge” in the safety instructions at the front of this guide.</p>
--

- 2. Refer to “Jumpers” and Table B-1 in Appendix B for jumper information, and to Figure B-1 for the location of the password jumper (labeled “PASSWD”) on the system board.**
- 3. Remove the jumper plug from the PASSWD jumper.**

- 4. Replace the computer cover according to the instructions in “Replacing the Computer Cover” in Chapter 6. Then reconnect the computer and peripherals to their power sources, and turn them on.**

Booting your system with the PASSWD jumper removed erases the existing password(s).

NOTE: Before you assign a new user and/or supervisor password, you must reinstall the PASSWD jumper plug.

- 5. Repeat step 1.**
- 6. Reinstall the PASSWD jumper plug on the PASSWD jumper.**
- 7. Replace the computer cover, reconnect your computer to its power source, and turn it on.**
- 8. Assign a new user and/or supervisor password.**

To assign a new user and/or supervisor password, see “Assigning or Changing a User Password” and “Assigning or Changing a Supervisor Password” found earlier in this section.

Chapter 6

Working Inside Your Computer

Your Dell computer system supports a variety of internal options that expand system capabilities. This chapter tells you how to remove the computer cover and familiarizes you with the internal components you may handle if you install Dell hardware options.

Before You Begin

To make working inside your computer easier, make sure you have adequate lighting and a clean work space. If you should have to disconnect cables or remove expansion cards temporarily, note the location and orientation of each component so that you can reassemble the system correctly.

You will use the information in this section every time you install a hardware option inside your computer. *Read this section carefully*, because the information is not repeated elsewhere in this guide.

Safety First—For You and Your Computer

Working inside your computer is safe—if you observe the following precautions:

WARNING FOR YOUR PERSONAL SAFETY AND PROTECTION OF YOUR EQUIPMENT

Before starting to work on your computer, perform the following steps in the sequence indicated:

1. **Turn off your computer and all peripherals.**
2. **Disconnect your computer and peripherals from their power sources to reduce the potential for personal injury or shock. Also, disconnect any telephone or telecommunications lines from the computer.**
3. **If you are disconnecting a peripheral from the computer or are removing a component from the system board, wait 5 seconds after turning off the computer before disconnecting the peripheral or removing the component to avoid possible damage to the system board.**
4. **Touch an unpainted metal surface on the outside of the computer chassis before touching anything inside the computer.**

While you work, periodically touch an unpainted metal surface on the computer chassis to dissipate any static electricity that might harm internal components.

In addition, Dell recommends that you periodically review the safety instructions at the front of this guide.

System Orientation

All directions presented in the procedures in this chapter are as viewed from a position facing the front of the computer.

Removing the Computer Cover

Use the following procedure to remove the computer cover:

1. **Observe the *Warning for Your Personal Safety and Protection of Your Equipment* found earlier in this chapter. Also observe the safety instructions at the front of this guide.**

2. **Remove the four cover-mounting screws that secure the cover to the chassis (Figure 6-1).**

Use the key provided with the system to remove the special keylock screw if it is installed in one of the cover-mounting screw locations. See Figure 1-2 for an illustration of the keylock screw and key.

3. **Slide the cover backward about one inch. Then grasp the front of the cover and the handle at the back of the cover, and lift it straight up off the chassis (Figure 6-1).**

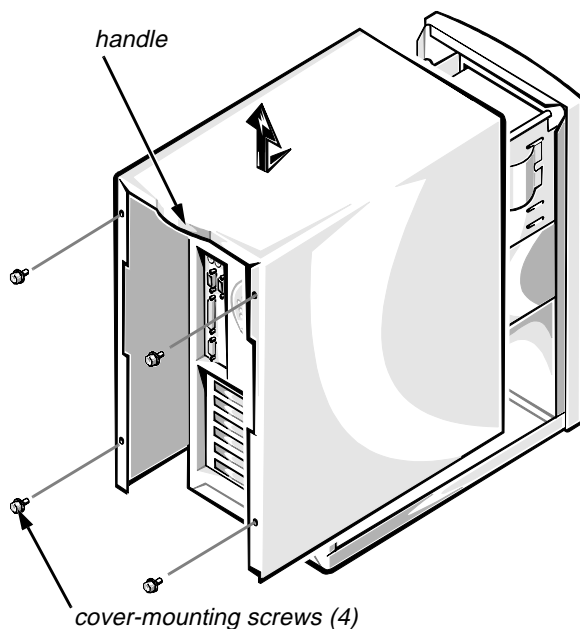

Figure 6-1. Removing the Computer Cover

Replacing the Computer Cover

Use the following procedure to replace the computer cover:

1. **Check all cable connections, especially those that might have come loose during your work. Fold cables out of the way so that they do not catch on the computer cover.**

CAUTION: Make sure that there are no cables or cable connectors lying on the diskette drive. Foreign objects on top of the drive can interfere with drive operation and permanently damage the drive.

2. **Check to see that no tools or extra parts (including screws) are left inside the computer.**
3. **Fit the cover over the chassis about 1 inch back of the closed position; then lower the cover straight down and slide it closed.**

The tabs located at the bottom, sides, and top of the front of the cover must slide inside the forms of the chassis to ensure a good electromagnetic interference (EMI) seal.

4. **Install and tighten the four cover-mounting screws on the back of the chassis.**

Reinstall the special keylock screw in place of one of the cover-mounting screws if you wish to prevent unauthorized access to the interior of the computer.

Removing the Front Bezel

Use the following procedure to remove the front bezel of the computer:

1. **Observe the *Warning for Your Personal Safety and Protection of Your Equipment* found earlier in this chapter. Also observe the safety instructions at the front of this guide.**
2. **Gently pry the bezel loose with your finger tips, and remove it from the chassis (see Figure 6-2).**

While prying the bezel loose, pry at different points around the bezel to keep the opening between the bezel and the chassis equal and help prevent damage to the bezel.

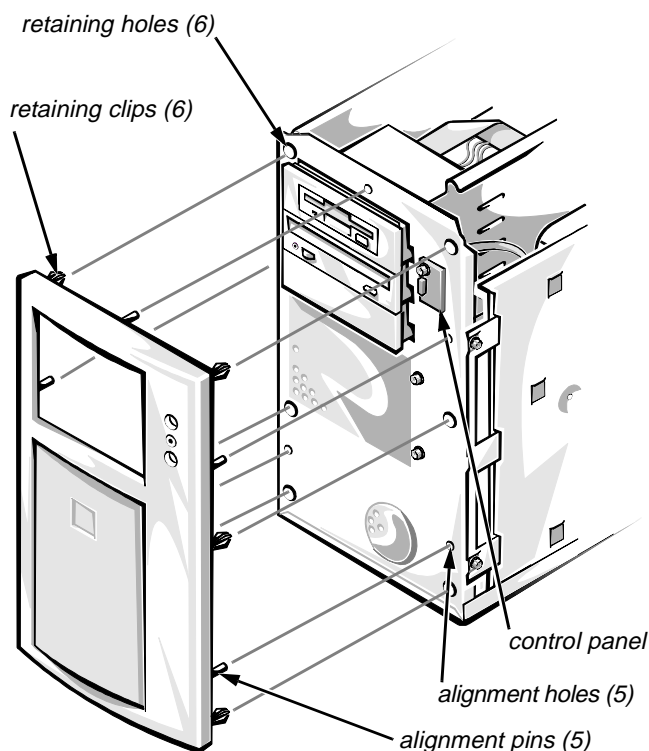

Figure 6-2. Removing the Front Bezel

remove the packing material until you are ready to install the option.

CAUTION: See “Protecting Against Electrostatic Discharge” in the safety instructions at the front of this guide.

Inside Your Computer

In Figures 6-3 and 6-4, the computer cover is removed to provide interior views. These illustrations also identify features on the front and back of the computer. Refer to them to locate interior features and components discussed later in this guide.

When you look inside your computer, note the direct current (DC) power cables coming from the power supply. These cables supply power to the system board, the externally accessible drives, and the internal hard-disk drives. Expansion cards obtain power through the system board.

The flat ribbon cables are the interface cables for internal drives. These interface cables are described in more detail in Chapter 8, “Installing Drives in the External Bays,” and Chapter 9, “Installing Drives in the Internal Bays.”

The system board—the large, vertical printed circuit board at the right side of the chassis—holds the computer’s control circuitry and other electronic components. Hardware options are installed directly onto the system board in the Peripheral Component Interconnect (PCI) or Extended Industry-Standard Architecture (EISA) expansion-card connectors. The external drive bays provide space for up to three half-height drives—typically a diskette drive is installed in the top bay, a CD-ROM drive in the middle bay, and the bottom bay is reserved for an optional drive (often a tape drive for backing up data from the hard-disk drives). The internal drive bays provide space for up to three 3.5-inch small computer system interface (SCSI) hard-disk drives. Drives installed in the internal drive bays can be up to 1.6 inches high.

During an installation procedure, you may be required to change a jumper or switch setting on the system board, on an expansion card, or on a drive. For more information, see “Jumpers” in Appendix B.

Replacing the Front Bezel

Use the following procedure to replace the front bezel of the computer:

1. **Insert the five plastic alignment pins on the front bezel into the alignment holes in the front of the chassis (Figure 6-2).**
2. **When the six metal retaining clips make contact with the retaining holes in the front of the chassis, press firmly to snap the bezel into position.**

Unpacking Your Hardware Option

When you remove an option from its shipping carton, you may find it wrapped in antistatic packing material designed to protect it from electrostatic damage. Do not

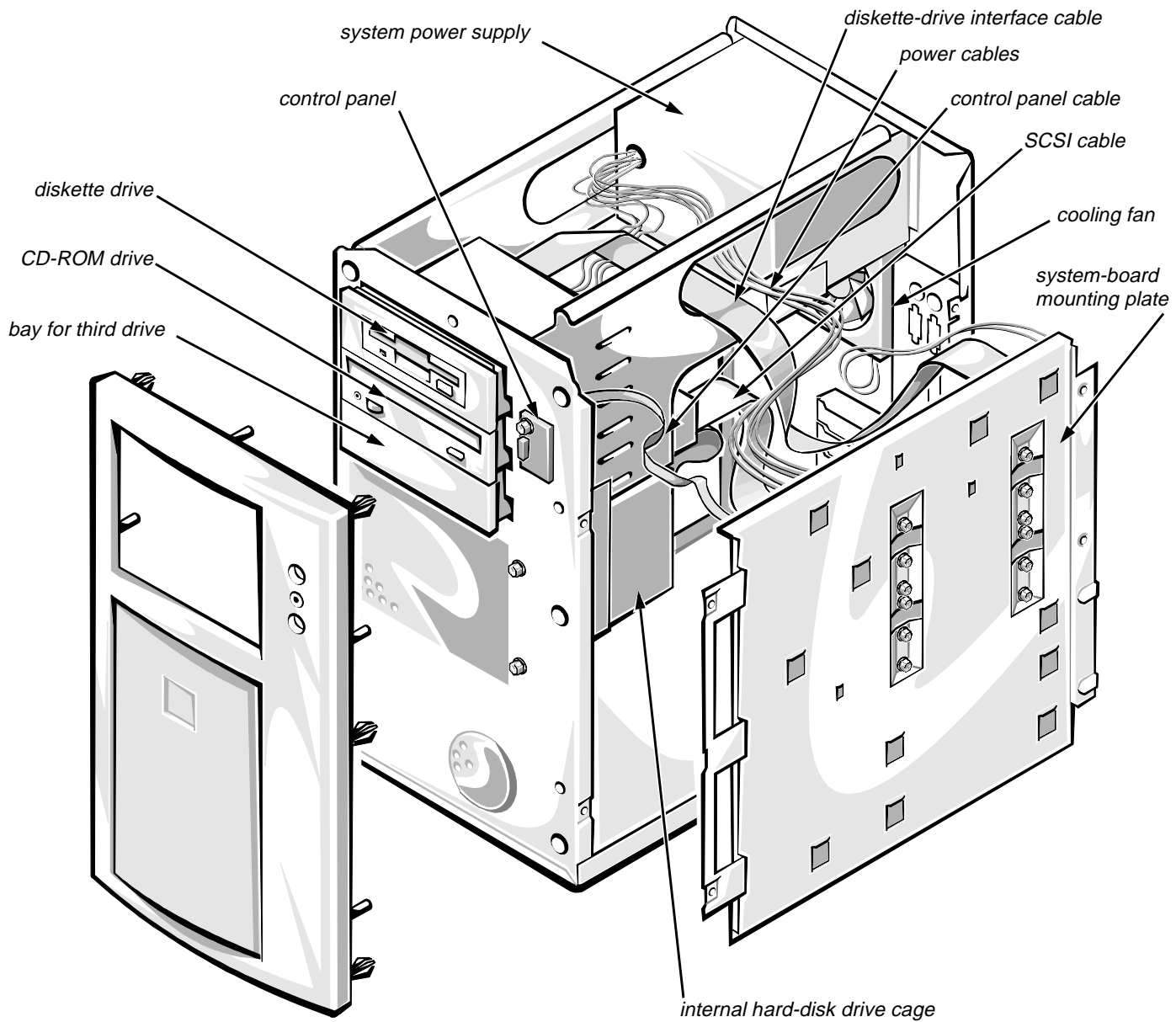

Figure 6-3. Inside the Chassis—Front/Right Side View

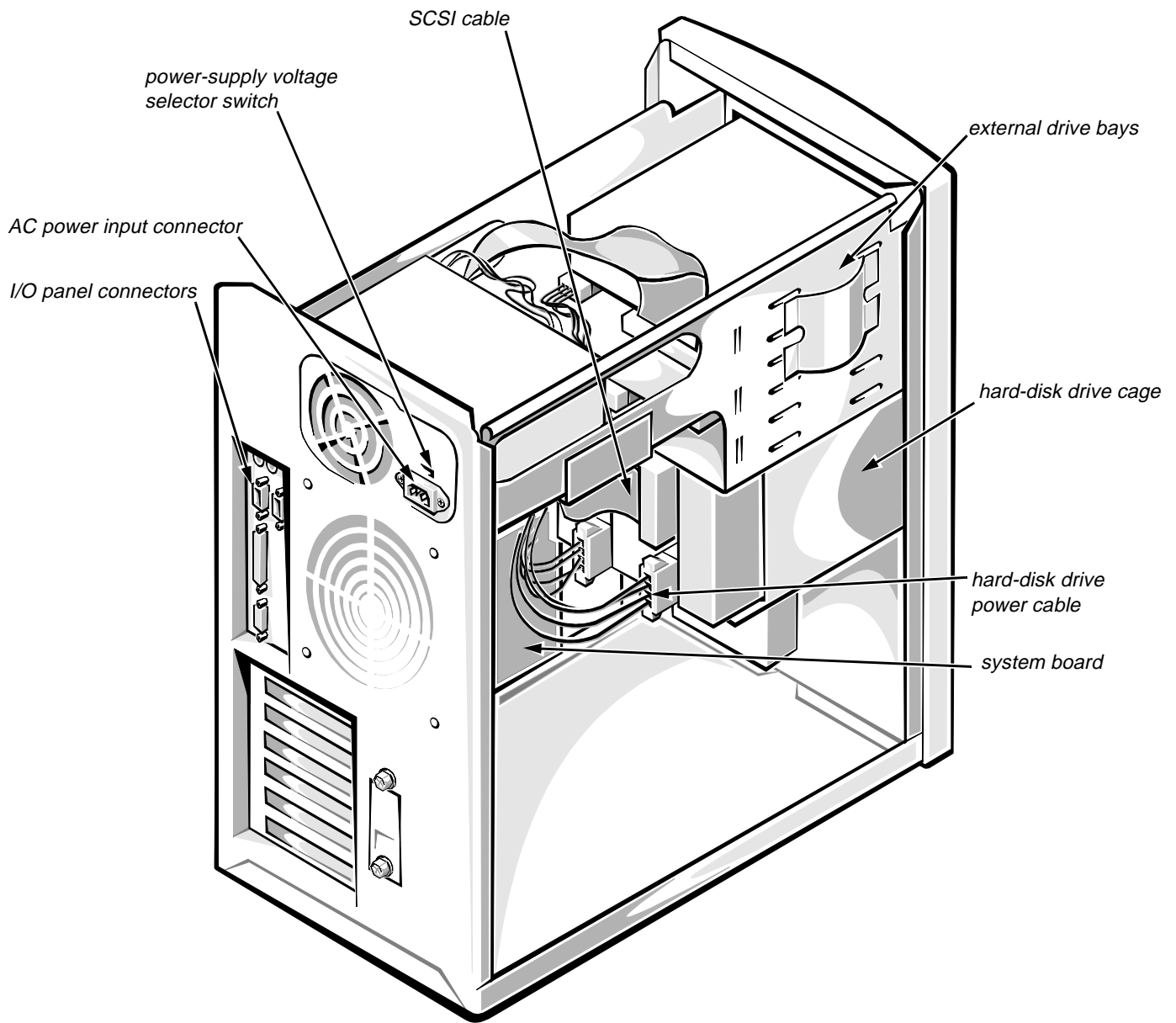

Figure 6-4. Inside the Chassis—Back/Left Side View

Removing and Replacing the System Board Assembly

When installing some hardware options, it may be more convenient to remove the system board assembly and place it on a flat work surface before performing the upgrade. The system board assembly in your computer has been designed to be easily removable.

NOTE: Before removing the system board assembly, write down or print out the system configuration information on the EISA Configuration Utility screen (see Figure 5-1). If you accidentally lose your system configuration settings during the following procedure, you can restore them by referring to the copy of the settings.

Removing the System Board Assembly

The system board assembly consists of the system board and a large metal mounting plate secured by four screws to the right side of the chassis. After the computer cover is removed, the system board assembly can be removed from the chassis as a single unit as follows:

1. **Remove the computer cover as described in “Removing the Computer Cover” found earlier in this chapter.**
2. **If there are no expansion cards installed, go to step 4. Otherwise, lay the computer on its right side so you can access the expansion cards.**
3. **Disconnect the cables from the expansion cards, and then remove the expansion cards. See “Removing an Expansion Card” in Chapter 7.**
Be sure to label the cables that you disconnect so they can be easily reconnected.
4. **Remove the four screws from the system board mounting plate assembly (see Figure 6-5).**

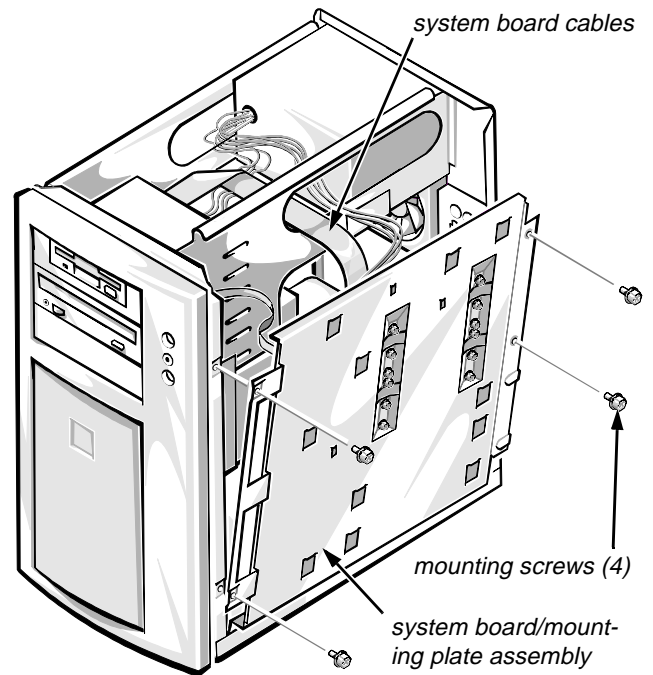

Figure 6-5. Removing the System Board Assembly

5. **Partially remove the system board assembly from the chassis.**
Tilt the system board assembly away from the chassis far enough so that you can access the cables and disconnect them as described in the next step.
6. **Disconnect the following cables from the system board.**

See Figure 7-1 to identify the following connectors on the system board. Disconnect the following cables (if any) connected to them:

- PANEL (for the front-panel cable)
- FLOPPY (for the diskette interface cable)
- HDLED (for the hard-disk drive access indicator cable)
- SCSI (for SCSI devices)
- FAN (for the fan cable)

- AUXFAN (for the cable to an auxiliary fan)
- POWER (for the power supply cable)
- POWER3V (for the 3-volt power supply cable)

7. **To work on the system board, place the system board assembly on a flat surface, with the system board facing up.**

Replacing the System Board Assembly

To replace the system board assembly in the chassis, perform the following steps:

1. **Reconnect the cables to the system board.**

Position the system board assembly near the chassis, and reconnect all cables you disconnected in step 6 of the preceding procedure. Double-check the cable connections before continuing.

2. **Install the system board assembly in the chassis.**

Facing the right side of the computer, hold the system board/mounting plate assembly in position. Align the input/output (I/O) connectors on the back of the system board with the openings in the back of the chassis, insert the system-board mounting plate under the two tabs on the chassis (Figure 6-6), and then slide the system board assembly toward the back of the computer until the mounting screw holes align with the holes in the chassis.

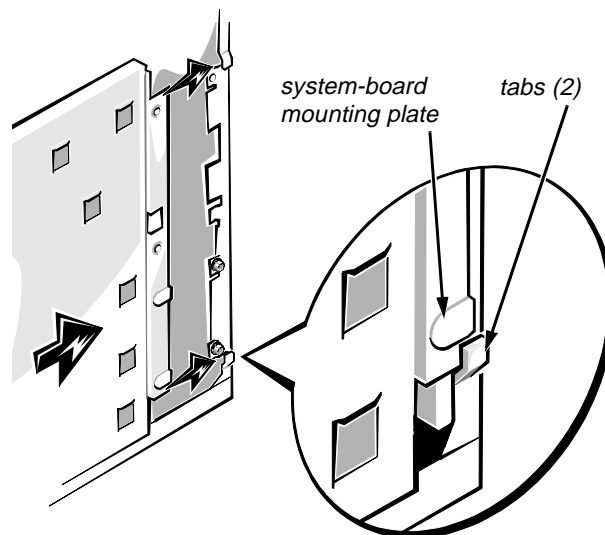

Figure 6-6. Replacing the System Board Assembly

3. **Replace and tighten the four mounting-plate screws.**
4. **Replace the computer cover as described in “Replacing the Computer Cover” found earlier in this chapter.**

Chapter 7

Installing System Board Options

This chapter describes installation of the following options:

- Extended Industry-Standard Architecture (EISA), Industry-Standard Architecture (ISA), and Peripheral Component Interconnect (PCI) expansion cards

- Dual in-line memory modules (DIMMs)
- Microprocessor upgrade

This chapter also includes instructions for replacing the system battery, if necessary.

Use Figure 7-1 to locate the system board features.

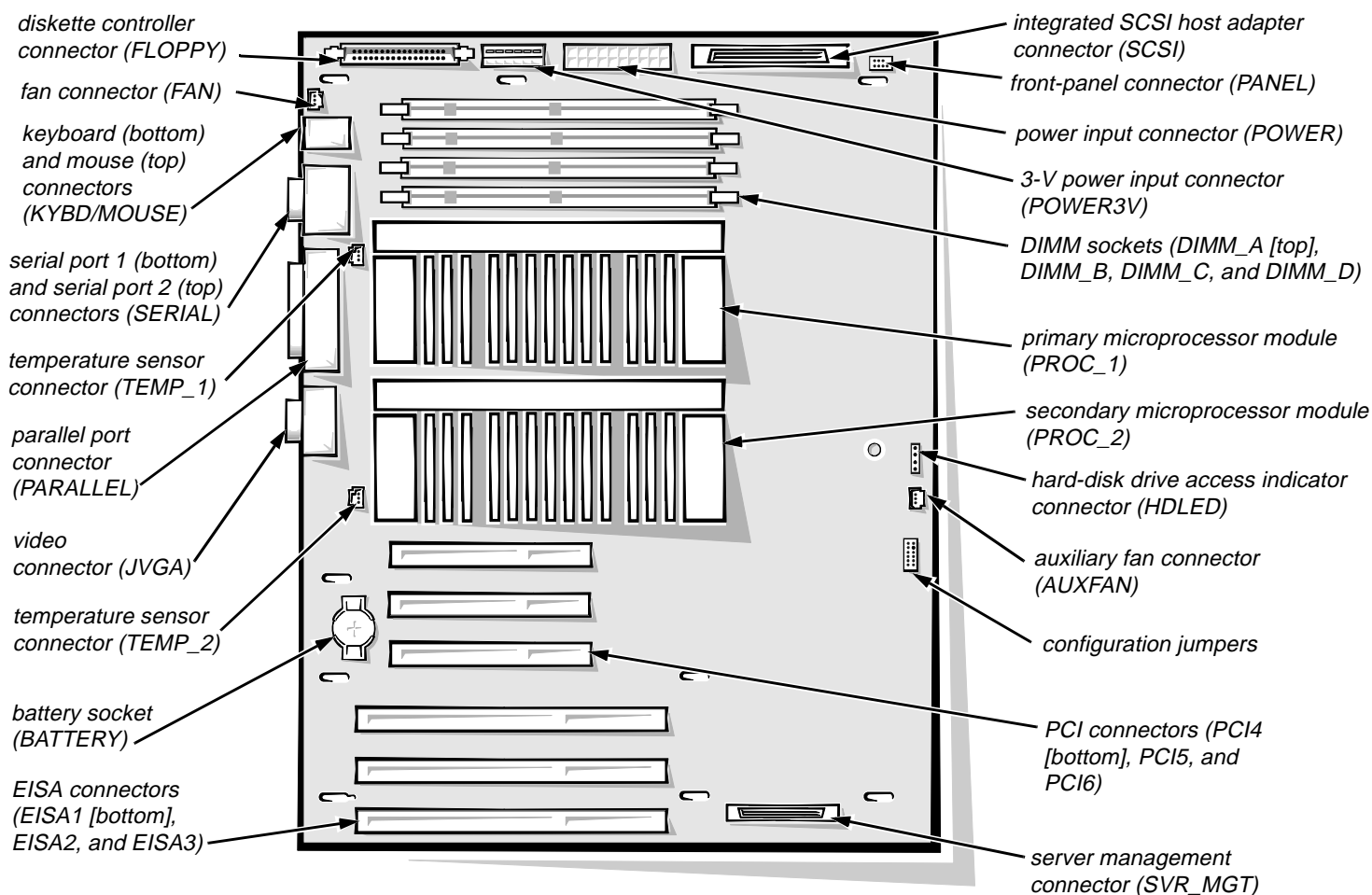

Figure 7-1. System Board Features

System Orientation

All directions presented in the procedures in this chapter are as viewed from a position facing the front of the computer. Use Figure 7-1 to locate items on the system board.

Expansion Cards

Your computer can hold up to six expansion cards. The three EISA expansion-card connectors will accept a mix of 8- and 16-bit ISA cards and/or 32-bit EISA master or slave cards. The three PCI expansion-card connectors accept 32-bit PCI cards.

Figure 7-2 shows examples of the different types of expansion cards.

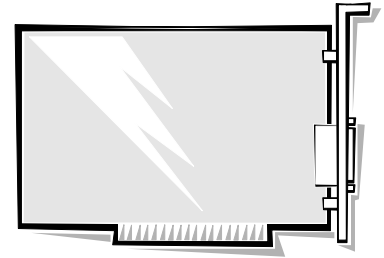

8-bit ISA expansion card

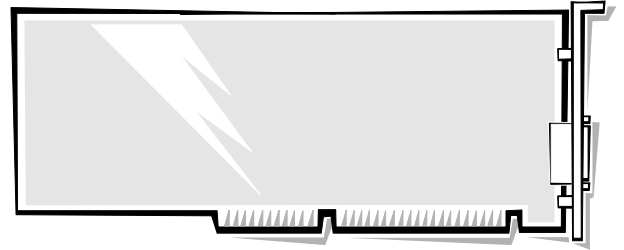

16-bit ISA expansion card

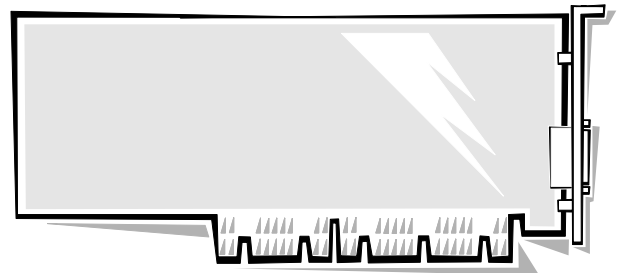

32-bit EISA expansion card

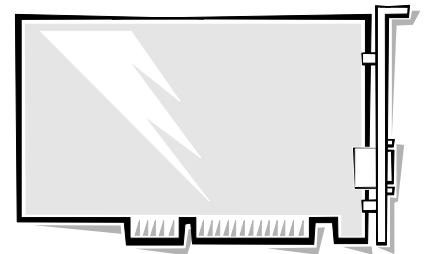

32-bit PCI expansion card

Figure 7-2. Expansion-Card Examples

Expansion Slots

The system board contains a total of six expansion-card connectors, three for EISA or ISA expansion cards and three for PCI expansion cards. An opening is available in the back panel of the computer for each expansion-card connector, thus providing six usable expansion slots.

Connectors EISA1 through EISA3 are EISA master slots. As such, each of these connectors can accommodate a 32-bit EISA master or slave card, or an 8- or 16-bit ISA expansion card.

Connectors PCI4, PCI5, and PCI6 support 32-bit PCI cards.

NOTES: If you install a Dell PowerEdge Expandable RAID Controller (PERC) host adapter card, you must install the card in connector PCI4.

If a Dell server management card is installed in the server management connector (SRV_MGT), the EISA1 connector cannot be used for an expansion card.

Installing an Expansion Card

Follow this general procedure to install an expansion card:

1. **If you are installing an ISA expansion card, start the EISA Configuration Utility and add the new card to your configuration so that PCI devices can be configured properly.**

See Chapter 5, “Using the EISA Configuration Utility,” for instructions.

*NOTES: If you are installing an EISA expansion card, you should normally run the EISA Configuration Utility **after** installing the expansion card.*

If you are installing a PCI expansion card, your system automatically performs any required PCI configuration tasks during the boot routine.

2. **Prepare the expansion card for installation, and remove the computer cover according to the instructions in “Removing the Computer Cover” in Chapter 6.**

CAUTION: See “Protecting Against Electrostatic Discharge” in the safety instructions at the front of this guide.

See the documentation that came with the expansion card for information on configuring the card, making internal connections, or otherwise customizing it for your system.

3. **With the cover removed, lay the computer (left side up) on a flat work surface so that you have access to the expansion card slots.**
4. **Remove the metal filler bracket that covers the card-slot opening for the expansion slot you intend to use (see Figure 7-3).**

Save the screw to use when installing the expansion card later in this procedure.

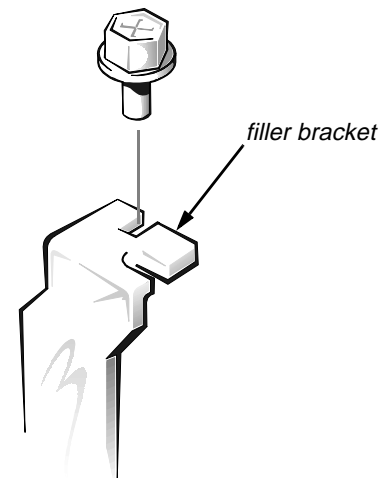

Figure 7-3. Removing the Filler Bracket

5. **If the expansion card is full-length, insert the end of the expansion card into the corresponding card guide slot on the inside front wall of the computer. Slide the card into the chassis.**
6. **Insert the card-edge connector firmly into the appropriate EISA or PCI expansion-card connector on the system board.**

Gently rock the card into the connector while you fit the metal card-mounting bracket into the card-slot opening on the back panel of the computer (see Figure 7-4).

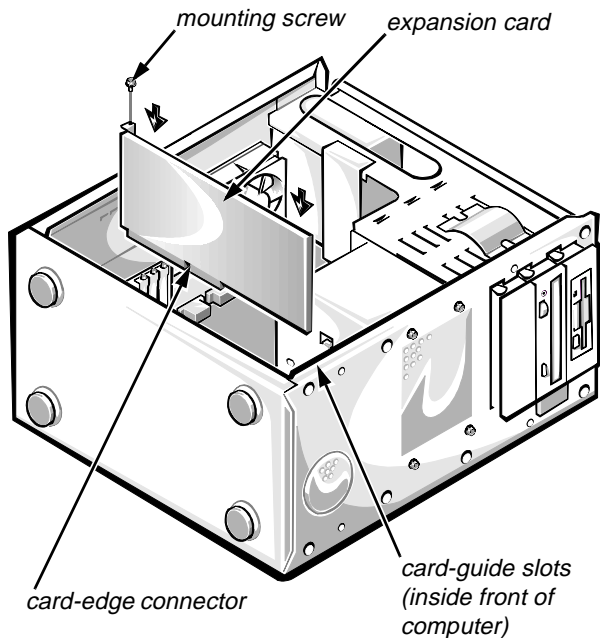

Figure 7-4. Installing an Expansion Card

7. When the card is firmly seated in the connector and the card-mounting bracket is flush with the brackets on either side of it, secure the card-mounting bracket with the screw you removed in step 4.
8. Connect any cables that should be attached to the card.
See the documentation that came with the card for information about its cable connections.
9. Replace the computer cover according to the instructions in “Replacing the Computer Cover” in Chapter 6, reconnect your computer and peripherals to their power sources, and turn them on.
10. If you are installing an EISA expansion card, start the EISA Configuration Utility and add the new card to your configuration.
See Chapter 5, “Using the EISA Configuration Utility,” for instructions.

Removing an Expansion Card

Follow this general procedure to remove an expansion card:

1. If you are relocating or permanently removing an ISA expansion card, enter the change into the EISA Configuration Utility.
See Chapter 5, “Using the EISA Configuration Utility,” for instructions.
2. Remove the computer cover according to the instructions in “Removing the Computer Cover” in Chapter 6.

CAUTION: See “Protecting Against Electrostatic Discharge” in the safety instructions at the front of this guide.

3. With the cover removed, lay the computer (left side up) on a flat work surface so that you have access to the expansion card slots.
4. If necessary, disconnect any cables connected to the expansion card.
5. Unscrew the card-mounting bracket.
6. Grasp the expansion card by its outside corners, and ease it out of its connector.
7. If you are removing the expansion card permanently, install a metal filler bracket over the empty card-slot opening.
NOTE: Installing filler brackets over empty card-slot openings is necessary to maintain Federal Communications Commission (FCC) certification of the system. The brackets also keep dust and dirt out of the computer and aid in proper cooling and air-flow inside the computer.
8. Replace the computer cover according to the instructions in “Replacing the Computer Cover” in Chapter 6, reconnect your computer and peripherals to their power sources, and turn them on.

9. If you relocated or permanently removed an EISA expansion card, enter the change into the EISA Configuration Utility.

See Chapter 5, “Using the EISA Configuration Utility,” for instructions.

NOTE: If you removed a PCI expansion card, your system automatically performs any required reconfiguration tasks during the boot routine.

Adding Memory

The four DIMM sockets (shown in Figure 7-5) on the system board can accommodate 32 to 512 megabytes (MB) of dynamic random-access memory (DRAM). The PowerEdge 2200 systems use 72-bit, buffered, extended-data output (EDO) DIMMs in these 168-pin sockets. Error correction code (ECC) checking is performed by the memory controller in the system board chip set. Figure 7-1 shows the location of the DIMM sockets on the system board.

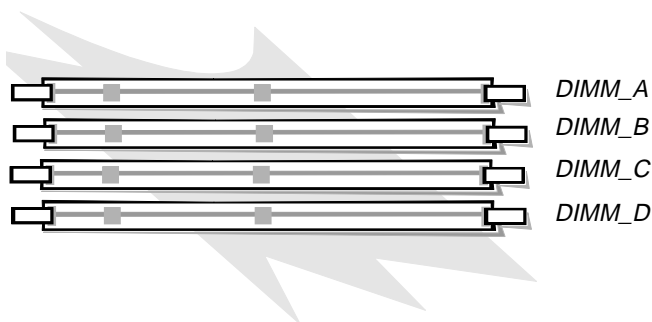

Figure 7-5. DIMMs and DIMM Sockets

Memory Upgrade Kits

Your system is upgradable to 512 MB by installing combinations of 32- and 128-MB DIMMs in the DIMM sockets. The DIMMs should be rated at 60 nanoseconds (ns) or faster.

Memory upgrade kits can be purchased from Dell as needed.

DIMM Installation Guidelines

Starting with the socket nearest the system board’s edge and working toward the center of the system board, the sockets are labeled “DIMM_A” through “DIMM_D” (Figure 7-5).

When installing DIMMs in sockets, follow these guidelines:

- Install a DIMM in socket DIMM_A before socket DIMM_B, in socket DIMM_B before socket DIMM_C, and so on.
- If you install different sizes of DIMMs, start with the largest (highest-capacity) DIMM in socket DIMM_A and work toward DIMM_D with the smaller DIMMs.

Table 7-1 illustrates these guidelines by listing sample memory configurations.

NOTE: The maximum memory supported in PowerEdge 2200 systems is 512 MB.

Table 7-1. Sample DIMM Configurations

Total Memory	DIMM Socket			
	DIMM_A	DIMM_B	DIMM_C	DIMM_D
32 MB	32 MB	None	None	None
64 MB	32 MB	32 MB	None	None
96 MB	32 MB	32 MB	32 MB	None
128 MB	32 MB	32 MB	32 MB	32 MB
128 MB	128 MB	None	None	None
192 MB	128 MB	32 MB	32 MB	None
256 MB	128 MB	128 MB	None	None
288 MB	128 MB	128 MB	32 MB	None
384 MB	128 MB	128 MB	128 MB	None
416 MB	128 MB	128 MB	128 MB	32 MB
512 MB	128 MB	128 MB	128 MB	128 MB

Performing a Memory Upgrade

Use the following procedure to perform a memory upgrade:

- 1. Remove the computer cover according to the instructions in “Removing the Computer Cover” in Chapter 6.**

CAUTION: See “Protecting Against Electrostatic Discharge” in the safety instructions at the front of this guide.

- 2. Remove the system board assembly according to the instructions in “Removing the System Board Assembly” in Chapter 6.**

Lay the system board assembly on a flat work surface so you can easily access the DIMM sockets.

- 3. Determine the DIMM sockets into which you will install or replace DIMMs.**

See the previous subsection, “DIMM Installation Guidelines.”

- 4. Install or replace the DIMMs as necessary to reach the desired memory total.**

Follow the instructions in “Installing a DIMM” or “Removing a DIMM,” as appropriate, later in this section.

- 5. Replace the system board according to the instructions in “Replacing the System Board Assembly” in Chapter 6.**

- 6. Replace the computer cover according to the instructions in “Replacing the Computer Cover” in Chapter 6, reconnect your computer and peripherals to their power sources, and turn them on.**

After the computer completes the power-on self-test (POST) routine, it runs a memory test that displays the new memory total, which includes all newly installed memory.

The system detects that the new memory does not match the system configuration information, which is stored in nonvolatile random-access memory (NVRAM), and generates the following error message:

```
System memory size has changed – Run  
Configuration Utility
```

```
Press F1 to resume, F2 to Setup
```

- 7. Press <F2> (when prompted while the computer is booting) to enter the System Setup program, and check the Extended Memory category on the main menu of the System Setup screens.**

The system should have already changed the value of the Extended Memory category to reflect the newly installed memory. Verify the new total.

NOTE: If the memory total is incorrect, turn off your computer and peripherals and disconnect them from their power sources. Remove the computer cover and system board, and check all the installed DIMMs to make sure they are seated properly in their sockets. Then repeat steps 6 and 7.

- 8. Enter the EISA Configuration Utility. Then save the configuration and exit the utility.**

Running the EISA Configuration Utility and saving the configuration is required for the system to recognize the newly installed DIMMs. See Chapter 5, “Using the EISA Configuration Utility,” for instructions on running the utility and saving the configuration.

NOTE: In the EISA Configuration Utility, the value of Extended Memory is specified in kilobytes. To convert megabytes to kilobytes, multiply the megabyte value by 1024.

- 9. When the Extended Memory total is correct, run the diskette-based diagnostics to test all installed DIMMs.**

See Chapter 2, “Using the Dell Server Assistant CD,” for information on running the diagnostics from the *Dell Server Assistant* CD. See the chapter titled “Running the Diskette-Based Diagnostics” in your *Diagnostics and Troubleshooting Guide* for information on the memory diagnostics.

Installing a DIMM

NOTE: The following procedure assumes that the system board assembly has been removed from the computer and is laying on a flat work surface. See “Removing and Replacing the System Board Assembly” in Chapter 6.

Install DIMMs starting with socket DIMM_A, located nearest the PCI expansion-card connector, and working toward socket DIMM_D, nearest the center of the system board. If a DIMM is already installed in the socket you need, you must remove it. Follow the instructions in the next subsection, “Removing a DIMM,” if appropriate.)

Use the following procedure to install a DIMM:

- 1. Press the ejectors on the DIMM socket down and outward, as shown in Figure 7-6, to allow the DIMM to be inserted in the socket.**
- 2. Align the DIMM’s edge connector with the slot in the center of the DIMM socket, and insert the DIMM in the socket.**

The card-edge connector on the DIMM is keyed so that the DIMM can only be installed in the socket in one way (Figure 7-6).

- 3. Press down on the two outer edges of the DIMM with your thumbs while pulling up on the ejectors with your index fingers to lock the DIMM into the socket.**

When the DIMM is properly seated in the socket, the ejectors on the DIMM socket should align with the ejectors on the other DIMM sockets.

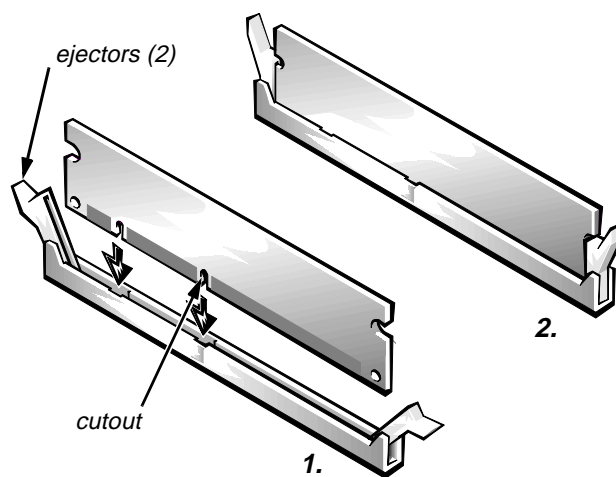

Figure 7-6. Installing a DIMM

4. Continue with step 5 of the previous subsection, “Performing a Memory Upgrade.”

Removing a DIMM

To remove a DIMM, press down and outward on the ejectors on each end of the DIMM socket until the DIMM pops out of the socket (Figure 7-7).

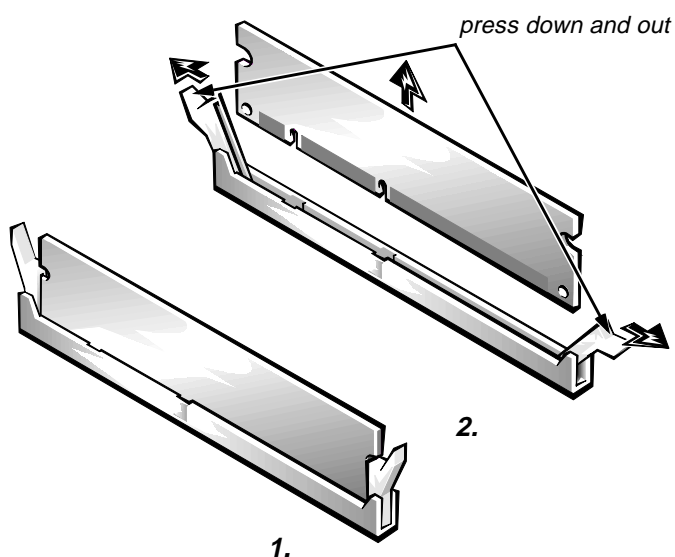

Figure 7-7. Removing a DIMM

Installing a Microprocessor

In addition to the connector for the primary microprocessor on the system board, there is a second connector to accommodate a secondary microprocessor. (In a single-microprocessor system, a terminator card is installed in the second microprocessor connector.)

The secondary microprocessor must have the same operating frequency as the primary microprocessor. For example, if the system has a 266-megahertz (MHz) Pentium II primary microprocessor, your secondary microprocessor must also be a 266-MHz Pentium II microprocessor.

NOTE: If you are upgrading a system by installing a secondary microprocessor, you must order a microprocessor upgrade kit from Dell. The upgrade kit from Dell contains the correct version of the microprocessor for use as a secondary microprocessor.

Use the following procedure to install a microprocessor.

NOTE: Dell recommends that only a technically knowledgeable person perform this procedure.

1. Remove the computer cover according to the instructions in “Removing the Computer Cover” in Chapter 6.

CAUTION: See “Protecting Against Electrostatic Discharge” in the safety instructions at the front of this guide.

2. Remove the system board assembly according to the instructions in “Removing the System Board Assembly” in Chapter 6.

WARNING: The microprocessor-module heat sink can get extremely hot. Be sure the microprocessor heat sink has had sufficient time to cool before proceeding.

3. If you are adding a second microprocessor, remove the terminator card from the secondary microprocessor connector.
 - a. First, remove the terminator-card retention bracket cover that secures the terminator card in place (see Figure 7-8). Using the thumb and forefinger of each hand, pinch the vertical tabs at each end of the cover, and then lift the cover straight up.
 - b. Remove the terminator card. Holding the card by its edges, lift the card straight up from the microprocessor connector.

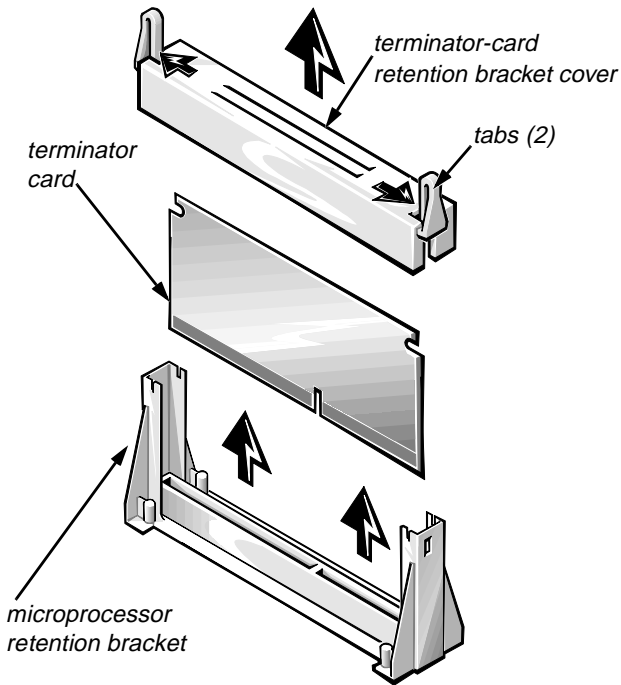

Figure 7-8. Terminator Card

4. If you are upgrading an existing microprocessor, remove the microprocessor module:

- a. Carefully stand the system board assembly on one edge. Using a 1/4-inch nut driver, remove the two hexagonal screws securing the microprocessor module to the system board (See Figure 7-9).

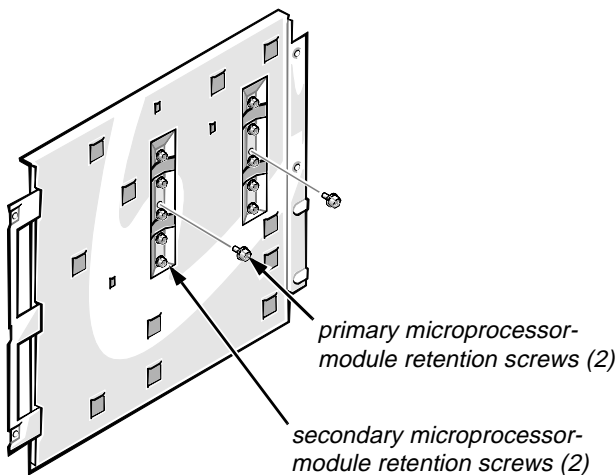

Figure 7-9. Microprocessor Module Retention Screws

- b. Disconnect the microprocessor temperature-sensor cable from the system board and the microprocessor module.
- c. Press inwards on the microprocessor-module retention latches (see Figure 7-10) until they snap into a retracted position.
- d. Lift the microprocessor module straight up and out of the microprocessor retention bracket on the system board.

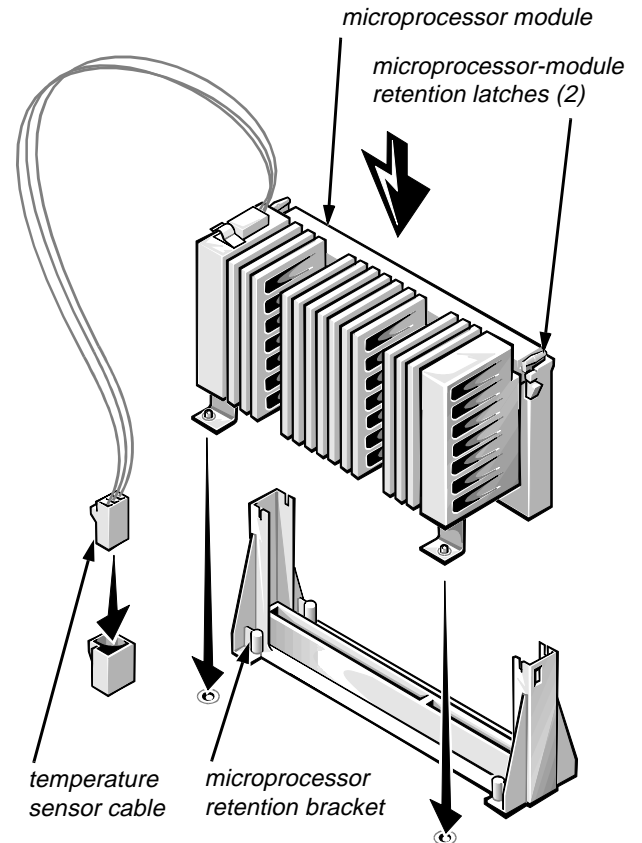

Figure 7-10. Installing a Microprocessor Module

5. Install the new microprocessor module.

Align the microprocessor module with the microprocessor retention bracket on the system board, as shown in Figure 7-10. Lower the microprocessor module into the microprocessor retention bracket, and press firmly on the top of the module until the microprocessor module is fully seated and the retention latches snap into position.

6. Reinstall the two screws securing the microprocessor module to the system board assembly.

Carefully stand the system board assembly on one edge, and reinstall the two hexagonal screws in the underside of the system board assembly (see Figure 7-9).

7. If necessary, change the microprocessor speed jumper setting to correspond to the new microprocessor's operating frequency.

The microprocessor speed jumper should be set for the installed microprocessor's rated internal speed. For example, for a 266-megahertz (MHz) Intel Pentium II processor, a jumper plug should be installed on the jumper labeled "266MHZ." (See Appendix B, "Hardware Configuration Features," for more information on jumpers.)

8. Connect the temperature sensor cable to the microprocessor module and to the system board (see Figure 7-10).

The cable for the primary microprocessor attaches to connector TEMP_1 on the system board, while the cable for the secondary microprocessor attaches to connector TEMP_2 on the system board. The connectors on the cable are keyed to ensure proper orientation.

9. Replace the system board according to the instructions in "Replacing the System Board Assembly" in Chapter 6.

10. Replace the computer cover according to the instructions in "Replacing the Computer Cover" in Chapter 6.

11. Reconnect your computer and peripherals to their power sources, and turn them on.

As the system boots, it detects the presence of the new microprocessor and automatically changes the system configuration information in the System Setup program.

12. Enter the System Setup program, and confirm that the Processor 1 and Processor 2 categories correctly identify the installed microprocessor(s).

See Chapter 4, "Using the System Setup Program."

13. Run the system diagnostics to verify that the new microprocessor is operating correctly.

See Chapter 2, "Using the Dell Server Assistant CD," for information on running the diagnostics from the *Dell Server Assistant* CD. The chapter titled "Running the Diskette-Based Diagnostics" in your Diagnostics and Troubleshooting Guide provides additional information on running the diagnostics and troubleshooting any problems that may occur.

Replacing the System Battery

The 3-volt (V) lithium backup battery (see Figure 7-11), mounted in the BATTERY socket on the system board (Figure 7-1), maintains system configuration, date, and time information in a special section of memory when the system is turned off and disconnected from alternating current (AC) power.

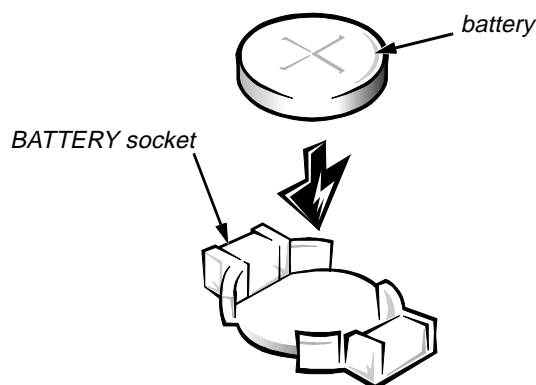

Figure 7-11. System Battery and Battery Socket

The operating life of the battery can extend up to 10 years, depending on how you use your system (for example, if your system is connected to AC power most of the time, the battery gets little use and thus lasts longer). The battery may need replacing if an incorrect time or date is displayed during the boot routine along with a message such as:

```
System battery is dead - Replace and run Setup
```

or

```
System CMOS checksum bad - Run Setup
```

To determine whether the battery needs replacing, re-enter the time and date through the System Setup program, and exit the program properly to save the information. Turn off your system and disconnect it from AC power for a few hours, and then reconnect power and turn it on again. Enter the System Setup program. If the date and time are not correct in the System Setup program, replace your battery.

NOTES: Some software may cause the system time to speed up or slow down. If your system seems to operate normally except for the time kept in the System Setup program, the problem may be caused by software rather than by a defective battery.

*If you leave your system disconnected from AC power for long periods of time (weeks or months), the NVRAM may lose its system configuration information. This situation is **not** caused by a defective battery.*

You can operate your system without a battery; however, the system configuration information is erased each time you turn off the computer and disconnect it from AC power. In this case, you must enter the System Setup program and reset the configuration options *each time you boot* your system until you can replace the battery.

Use the following procedure to replace the computer battery:

- 1. If you have not already done so, make a copy of or print your system configuration information in the System Setup program.**

If the settings are lost while replacing the battery, refer to your written or printed copy to restore the correct settings. See Chapter 4, "Using the System Setup Program," for instructions.

- 2. Remove the computer cover according to the instructions in "Removing the Computer Cover" in Chapter 6.**

CAUTION: See "Protecting Against Electrostatic Discharge" in the safety instructions at the front of this guide.

- 3. Lay the computer on its right side on a flat work surface to allow access to the battery on the system board.**

- 4. Remove any PCI expansion cards that prevent access to the battery.**

See "Removing an Expansion Card" found earlier in this chapter. Be sure to label any external connections to the PCI cards when you remove them to facilitate correct reinstallation.

- 5. Remove the old battery.**

Pry the backup battery out of its socket with your fingers or a blunt object, such as a plastic screwdriver.

NOTE: Dispose of the old battery in accordance with local ordinances.

- 6. Install the new battery with the side labeled "+" facing up.**

Place the new battery in the socket, and press down on it until the battery snaps into the socket.

- 7. If you removed any PCI expansion cards, replace them according to the instructions in "Installing an Expansion Card" found earlier in this chapter.**

- 8. Replace the computer cover according to the instructions in "Replacing the Computer Cover" in Chapter 6, reconnect your computer and peripherals to their power sources, and turn them on.**

- 9. Enter the System Setup program, and confirm that the battery is operating properly. See Chapter 4, "Using the System Setup Program."**

Enter the correct time and date through the System Setup program's Time and Date categories. Also, re-enter any system configuration information that is no longer displayed on the System Setup screens, and then exit the System Setup program.

Chapter 8

Installing Drives in the External Bays

The external drive bays at the front of the computer (Figure 8-1) hold up to three user-accessible, half-height 5.25- or 3.5-inch devices—typically diskette, tape, CD-ROM, or digital audio tape (DAT) drives. Standard PowerEdge 2200 systems include a diskette drive in the top bay and a CD-ROM drive in the middle bay. A drive of your choice can be installed in the lower bay.

The diskette drive is controlled by the system board's built-in diskette controller. The CD-ROM drive provided with the system and an additional small computer system interface (SCSI) drive (if installed in the lower bay) are controlled by the system board's built-in SCSI controller.

NOTE: Dell PowerEdge 2200 systems support only SCSI hard-disk drives in the internal drive bays. For more information, see Chapter 9, "Installing Drives in the Internal Bays."

Configuring a Drive

Because you may need to tailor a drive to work with your system, certain installation instructions in this chapter refer you to the documentation that came with the drive for information on changing jumper settings.

Jumpers

Drives installed by Dell are configured to work with your system. However, you should check the documentation for the drive to verify that the jumpers are set correctly for your particular configuration, and make any necessary alterations. (For an explanation of jumpers, see "Jumpers" in Appendix B.)

For example, when daisy-chaining two drives together, you may need to reconfigure one or both drives to differentiate between them for proper operation.

See Figure 8-1 for an internal view that shows the drives, interface cables, and power cables in the external bays.

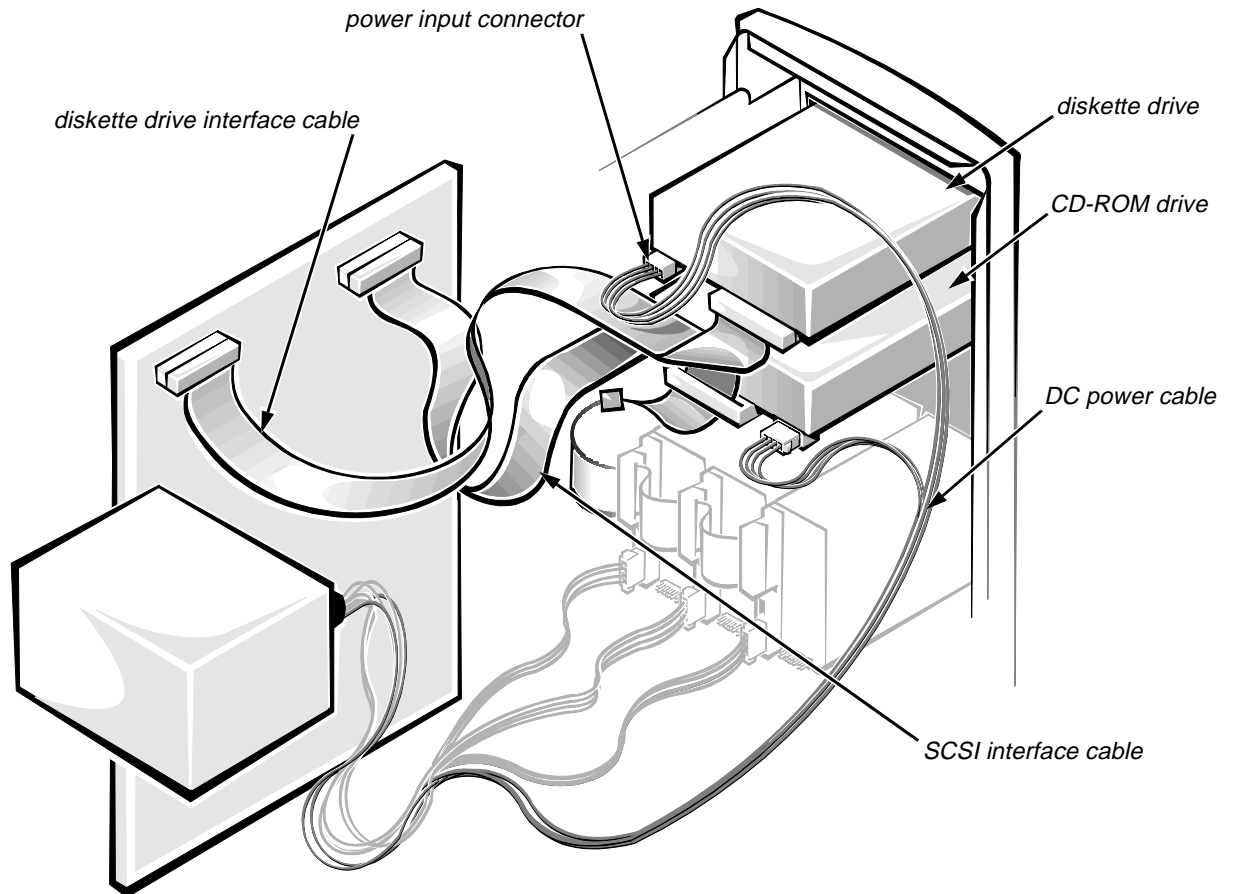

Figure 8-1. External Drive Bay Hardware

Before You Begin

In order to remove or install drives in the external bays, you must remove the computer cover and front bezel according to the instructions in “Removing the Computer Cover” and “Removing the Front Bezel” in Chapter 6.

Removing and Replacing Front-Panel Inserts

To protect the inside of the computer from foreign particles, a plastic front-panel insert covers each empty external drive bay. Additionally, each empty drive bay is covered by a metal insert to maintain the necessary electromagnetic interference (EMI) shielding for the chassis.

Before you install a drive in an empty bay, you must first remove the plastic and metal inserts.

Whenever you remove a drive, be sure to replace the metal insert on the chassis and then replace the plastic insert in the front bezel to cover the empty bay.

Removing and Replacing Plastic Inserts

To remove the plastic insert for a drive bay you intend to use, first remove the front bezel as instructed in “Removing the Front Bezel” in Chapter 6. Then, facing the inside of the front bezel, grasp the front bezel with both hands and place your fingers on the outside of the front-bezel insert (as indicated by the two arrows in Figure 8-2). Push on the outside of the front-bezel insert while twisting the sides of the front bezel outward until the front-bezel insert is released.

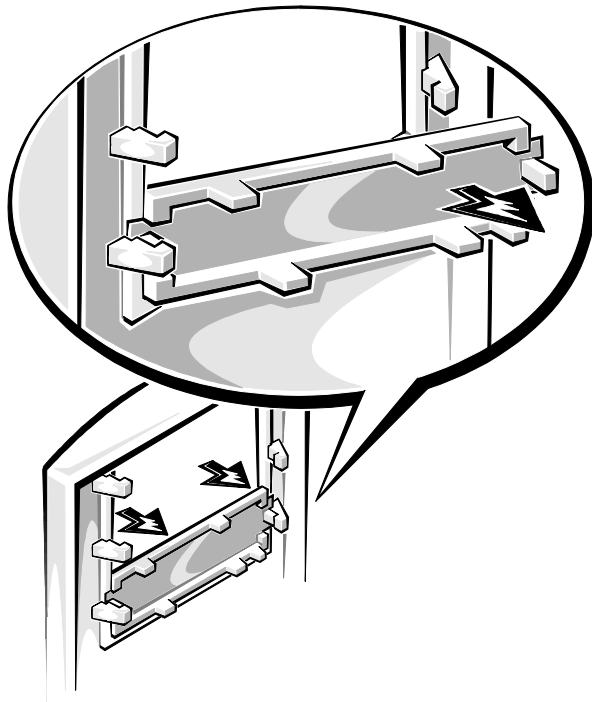

Figure 8-2. Removing a Plastic Insert

To replace a front-panel insert, position the insert over the bay opening from the inside of the front bezel and carefully press the insert into place. A tab on each side of the insert snaps into a corresponding latch on the inside of the front bezel.

Removing Metal Inserts

To remove the metal insert for a drive bay you intend to use, first remove the front bezel as instructed in “Removing the Front Bezel” in Chapter 6. Next, remove the retaining screw at the right end of the metal insert (see Figure 8-3), and then pivot the metal insert out and slide it to the right.

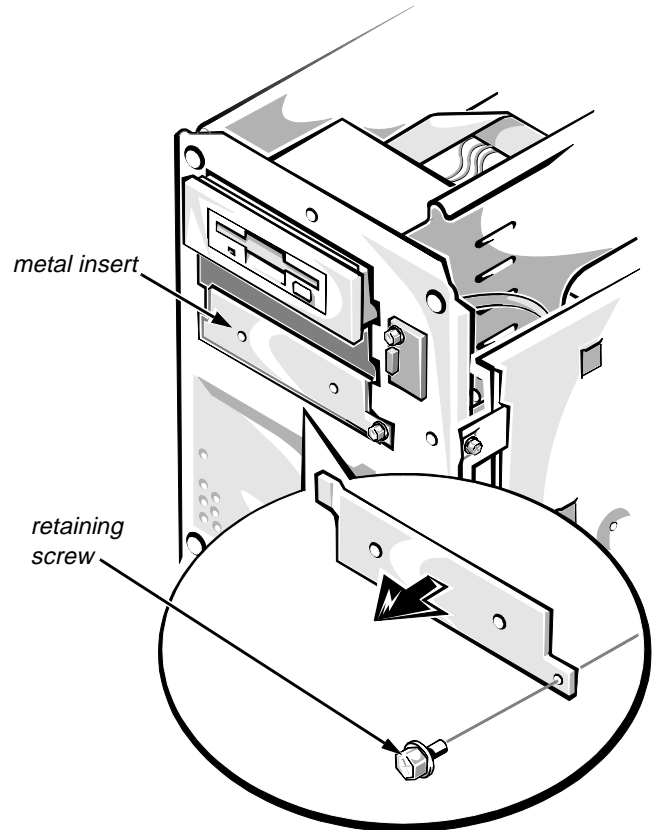

Figure 8-3. Removing a Metal Insert

Connecting the Drive

This section describes the power input connectors and interface connectors on the back of most drives.

Figure 8-4 shows the 4-pin *power input connector*, where you connect a direct current (DC) power cable from the power supply. The power connectors are *keyed* to avoid incorrect insertion; do not force two connectors together if they do not fit properly.

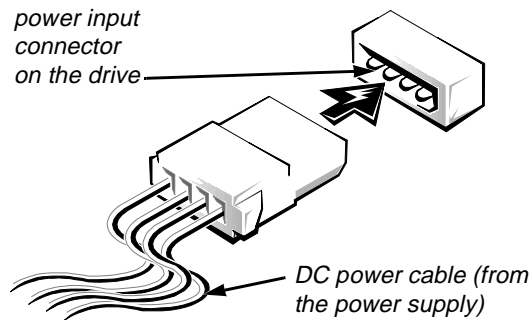

Figure 8-4. Power Connectors

A ribbon cable (see Figure 8-5) functions as the interface cable for most types of drives.

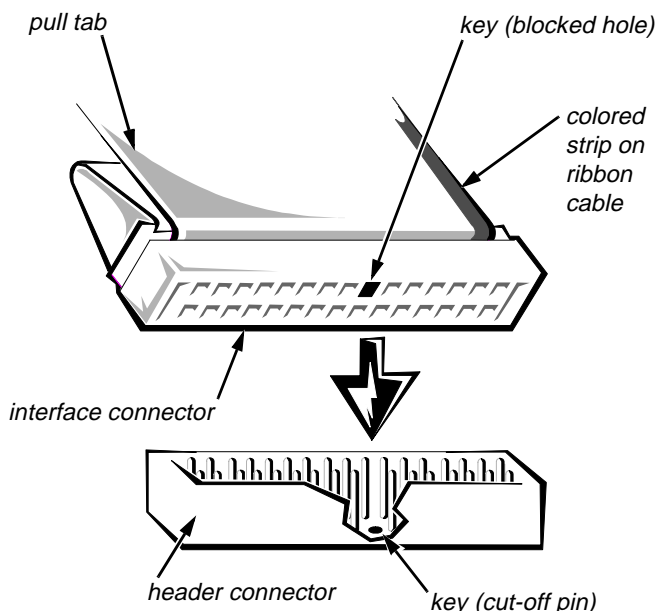

Figure 8-5. Interface Connectors

Most interface connectors are keyed for correct insertion; that is, a notch or a missing pin on one connector matches a tab or a filled-in hole on the other connector. Keying ensures that the pin-1 wire in the cable (indicated by the colored strip along one edge of the cable) goes to the pin-1 ends of the connectors on both ends.

The *header connector* on the drive is usually keyed by the omission of one of its pins, with the corresponding hole filled in on the interface cable connector, as shown in Figure 8-5.

CAUTION: When connecting an interface cable, match the colored strip to the pin-1 end of the connector. Reversing the cable prevents the drive from operating and could damage the controller, the drive, or both.

DC Power Cables

Figure 8-6 identifies the different types of connectors on the DC power cables coming from the computer's power supply. Before connecting a drive to a power cable, refer to Figure 8-6 to identify the correct cable connector to use for the drive.

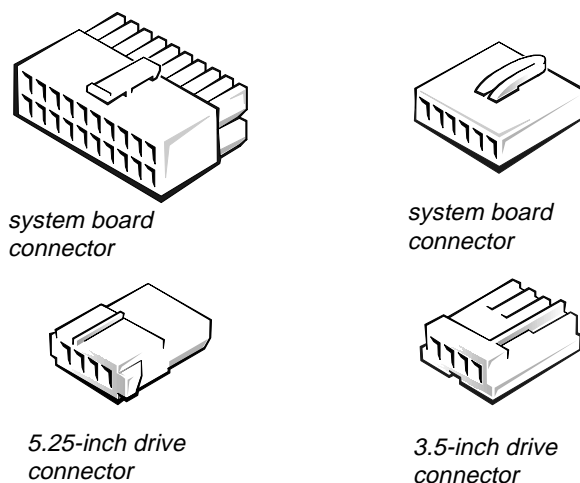

Figure 8-6. DC Power Cable Connectors

Installing Drives in the External Bays

The external drive bays (see Figure 8-7) can hold up to three half-height devices. A diskette drive is standard in the top bay and a CD-ROM drive is standard in the middle bay. The lower bay can be used for a SCSI drive or a drive that requires its own controller card and interface cable, such as some kinds of tape drives.

Installing Diskette Drives That Use the Diskette Drive Controller

To install a 5.25- or 3.5-inch diskette drive that uses the built-in diskette drive controller, follow these steps:

1. Prepare the drive for installation.

Ground yourself by touching an unpainted metal surface on the back of the computer, unpack the drive, and compare the jumper settings with those in the drive documentation. Change any settings necessary for your system's configuration.

If the drive does not already have drive rails attached, attach a drive rail to each side of the drive. Orient the drive rails as shown in Figure 8-9. Secure each drive rail to the drive with a screw in the first (from the front) and third slotted screw holes on the drive rail as shown in Figure 8-9.

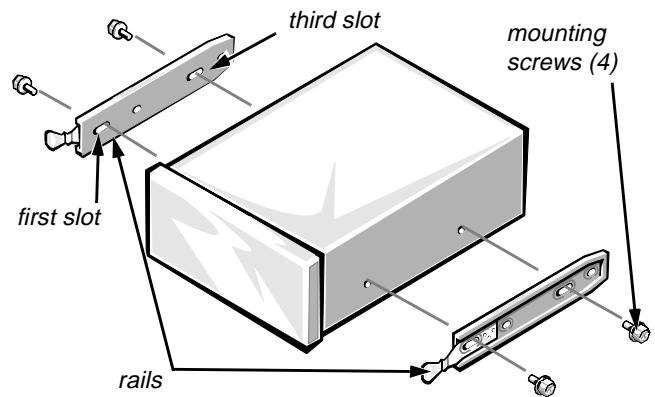

Figure 8-9. Attaching Drive Rails

2. Remove the computer cover and front bezel according to the instructions in "Removing the Computer Cover" and "Removing the Front Bezel" in Chapter 6.

CAUTION: See "Protecting Against Electrostatic Discharge" in the safety instructions at the front of this guide.

3. Slide the new drive into its bay until it snaps securely into place.

If necessary, you can adjust drive alignment by repositioning one or both rails.

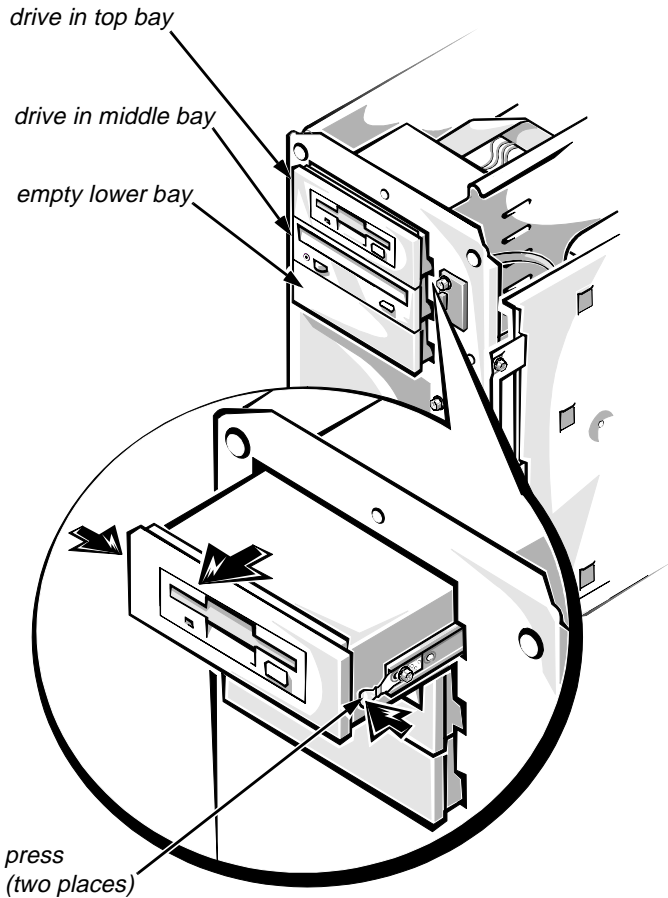

Figure 8-7. Drives in the External Bays

The diskette drive interface cable (see Figure 8-8) provides an interface between the standard diskette drive in the top bay and the computer's built-in diskette controller. The connectors on the cable are identical; however, the ends of the cable are labeled "CNTL" for the diskette controller connector (FLOPPY) and "DRIVE" for the diskette drive connector. (To identify the FLOPPY connector, see Figure 7-1.)

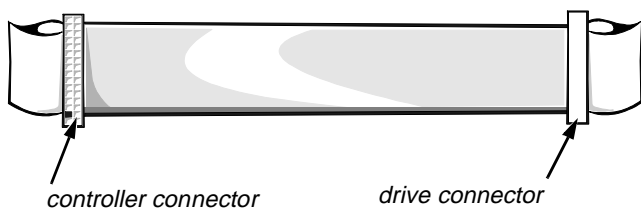

Figure 8-8. Diskette Drive Interface Cable

4. Connect a DC power cable and the diskette interface cable to the back of the drive (see Figure 8-1).

If other installed drives are in the way, temporarily move them out of the way. Press in on the plastic drive rails at the front of the bay to disengage a drive; then slide the drive toward the front of the chassis (see Figure 8-7).

Refer to Figure 8-6 to determine which DC power cable connector to use, depending on the type of drive. Plug the DC power cable into the 4-pin power input connector on the back of the drive.

CAUTION: Check the cable orientation—match the colored strip to the pin-1 end of the connector.

Press the interface cable connector firmly onto the drive's connector. Be sure that the interface cable is routed through the slot in the upper chassis rail to prevent interference with other devices.

If you moved other drives at the beginning of this step, snap them back into place.

5. Check all cable connections that may have been loosened during this procedure. Arrange cables so they will not catch on the computer cover or block the airflow of the fans or cooling vents.

6. If a front-panel insert on the front bezel blocks the bay in which you installed the drive, remove the insert (see “Removing and Replacing Front-Panel Inserts” found earlier in this chapter).

7. Replace the computer cover and front bezel according to the instructions in “Replacing the Computer Cover” and “Replacing the Front Bezel” in Chapter 6.

8. Reconnect your computer and peripherals to their power sources, and turn them on.

9. Update your system configuration information.

Enter the System Setup program, and if you installed a diskette drive, update the Diskette Drive A category to reflect the size and capacity of your new diskette drive.

10. Verify correct operation of your system.

See Chapter 2, “Using the Dell Server Assistant CD,” for information on running the diagnostics from the *Dell Server Assistant* CD. See the chapter titled “Running the Diskette-Based Diagnostics” in your *Diagnostics and Troubleshooting Guide* for information on running the diagnostics. Test the drive by running all the subtests in the Diskette Drives Test Group of the diskette-based diagnostics.

Installing SCSI Drives in the External Bays

1. Prepare the drive for installation.

Ground yourself by touching an unpainted metal surface on the back of the computer, unpack the drive, and compare the jumper and switch settings with those in the drive documentation. (See “SCSI Configuration Guidelines” in Chapter 9 for information on setting the drive's SCSI identification [ID] number and enabling termination, if required). Change any settings necessary for your system's configuration.

If the drive does not already have drive rails attached, attach a drive rail to each side of the drive. Orient the drive rails as shown in Figure 8-9. Secure each drive rail to the drive with a screw in the first and third slotted screw holes on the drive rail as shown in Figure 8-9.

2. Remove the computer cover and front bezel according to the instructions in “Removing the Computer Cover” and “Removing the Front Bezel” in Chapter 6.

CAUTION: See “Protecting Against Electrostatic Discharge” in the safety instructions at the front of this guide.

3. Slide the new drive into its bay until it snaps securely into place.

If necessary, you can adjust drive alignment by repositioning one or both rails.

4. Connect a DC power cable and one of the connectors on the SCSI interface cable to the back of the drive (see Figure 8-1).

Refer to Figure 8-6 to determine which DC power cable connector to use, depending on the type of drive.

Plug the DC power cable into the 4-pin power input connector on the back of the drive.

Use either of the two external SCSI connectors nearest the system board connector on the SCSI interface cable (see Figure 9-2).

NOTE: You will need a 68-pin to 50-pin adapter to connect the SCSI cable to the narrow (50-pin) connector on the CD-ROM or tape drive (Figure 8-10).

Press the interface cable connector firmly onto the adapter and the adapter firmly onto the drive's connector.

If you moved other drives at the beginning of this step, snap them back into place.

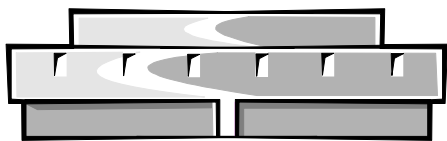

Figure 8-10. 68-Pin to 50-Pin Adapter

5. **Check all cable connections that may have been loosened during this procedure. Arrange cables so they will not catch on the computer cover or block the airflow of the fans or cooling vents.**
6. **If a front-panel insert on the front bezel blocks the bay in which you installed the drive, remove the insert (see “Removing and Replacing Front-Panel Inserts” found earlier in this chapter).**
7. **Replace the computer cover and front bezel according to the instructions in “Replacing the Computer Cover” and “Replacing the Front Bezel” in Chapter 6.**
8. **Reconnect your computer and peripherals to their power sources, and turn them on.**
9. **Verify correct operation of your system.**

See Chapter 2, “Using the Dell Server Assistant CD,” for information on running the diagnostics from the *Dell Server Assistant* CD. See the chapter titled “Running the Diskette-Based Diagnostics” in your *Diagnostics and Troubleshooting Guide* for information on running the diskette-based diagnostics. Test the new SCSI drive by running all the subtests in the

SCSI Devices Test Group of the diskette-based diagnostics.

Perform a tape backup and verification test with the tape drive as instructed in the documentation for the tape drive software that came with the drive.

Installing an Optional SCSI Controller for the External Bay SCSI Drives

Performance of the SCSI hard-disk drives in the internal bays can be increased by adding an optional SCSI controller card to control the CD-ROM drive and any other SCSI device installed in the external bays. The optional Adaptec AHA-2940 SCSI controller is available from Dell in a kit that includes an interface cable with 50-pin connectors for narrow SCSI devices.

Use the following procedure to install an optional SCSI controller card for the SCSI devices in the external bays.

1. Configure the controller card if necessary.

Refer to the documentation accompanying the SCSI controller card. If the card incorporates jumpers that must be set to work with your system, verify or change the settings as necessary.

Enable termination for the controller according to the instructions in “SCSI Configuration Guidelines” in Chapter 9.

2. Remove the computer cover according to the instructions in “Removing the Computer Cover” in Chapter 6.

CAUTION: See “Protecting Against Electrostatic Discharge” in the safety instructions at the front of this guide.

3. Install the controller card in an expansion slot.

See “Installing an Expansion Card” in Chapter 7.

4. Connect one end of the interface cable that came with the SCSI controller card to the controller connector on the card (Figure 8-11).

One end of the interface cable has a single connector; the other end has two connectors. Connect the single connector to the SCSI controller card.

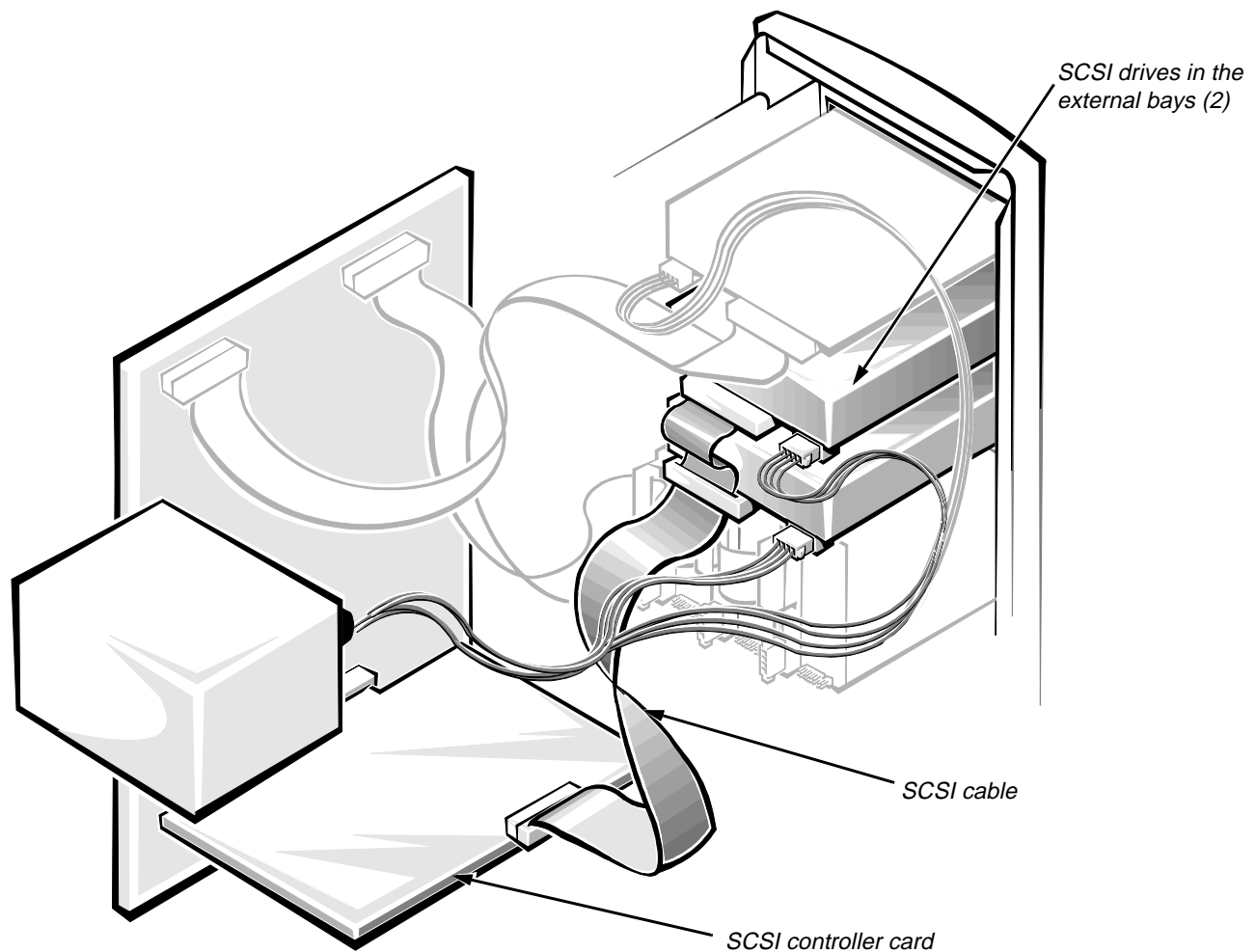

Figure 8-11. Connecting an Optional SCSI Controller Card

5. **Connect the other end of the interface cable to the SCSI drives in the external bays.**

If you have more than one SCSI device in the external bays, you should connect the end connector on the interface cable to the CD-ROM drive and enable termination for the CD-ROM drive. See “SCSI Configuration Guidelines” in Chapter 9 for instructions on enabling termination.

6. **Connect the two-wire cable supplied with the SCSI controller card to the drive activity connector on the card and the hard-disk drive access indicator connector (HDLED) on the system board (see Figure 7-1).**

7. **Replace the computer cover according to the instructions in “Replacing the Computer Cover” in Chapter 6.**
8. **Reconnect your computer and peripherals to their power sources, and turn them on.**
9. **Verify correct operation of your system.**

Refer to the chapter titled “Running the Diskette-Based Diagnostics” in your *Diagnostics and Troubleshooting Guide*, and run the appropriate tests in the SCSI Devices Test Group to verify that the new SCSI controller is functioning correctly.

Chapter 9

Installing Drives in the Internal Bays

This chapter describes how to install and configure small computer system interface (SCSI) hard-disk drives in the internal drive bays. Up to three 1.6-inch SCSI hard-disk drives can be installed in the internal hard-disk drive bays.

NOTE: You should install only SCSI hard-disk drives in the internal drive bays; install SCSI CD-ROM and tape drives in the external drive bays.

Dell PowerEdge 2200 systems have a built-in Adaptec AIC-7880 Ultra/Wide (fast-20) SCSI-2 controller on the system board, accessible via a 68-pin SCSI connector on the system board. This single-channel SCSI controller features active termination, which provides for better signal quality at fast SCSI-2 speeds. You can attach a variety of SCSI devices (hard-disk drives, tape drives, and so on) to the built-in SCSI controller, which configures all devices attached to it as one subsystem—not as independent devices.

NOTE: If you choose to install an additional or alternative SCSI controller card, install the card as described in “Installing an Expansion Card” in Chapter 7. Before installing the card, be sure to check the documentation that accompanied it for information on configuring the card. When installing and cabling the devices, use the general SCSI configuration guidelines provided in the following section; check the documentation that accompanied your SCSI controller card and/or your SCSI devices for any additional configuration requirements.

SCSI Configuration Guidelines

Although SCSI devices are installed essentially the same way as other devices, their configuration requirements are different. To configure your SCSI subsystem, follow

the general guidelines offered in the following subsections.

SCSI ID Numbers

Each device attached to the SCSI host adapter must have a unique SCSI identification (ID) number from 0 to 15.

NOTE: Any narrow SCSI devices installed in the external drive bays require SCSI ID numbers less than 7.

When SCSI devices are shipped from Dell, the default SCSI ID numbers are assigned as follows:

- The computer’s built-in SCSI controller is configured through the basic input/output system (BIOS) as SCSI ID 7 (the default ID number for a host adapter) if the system includes a CD-ROM or tape drive.
NOTE: If only wide SCSI hard-disk drives (no CD-ROM or tape drives) are connected to the built-in SCSI controller, it may be configured as SCSI ID 15.
- A SCSI CD-ROM drive (installed in an external bay) is configured as SCSI ID 5.
- A SCSI tape drive (if installed) is configured as SCSI ID 6.
- The drive you intend to use as your *boot device* should be configured as SCSI ID 0. You can configure any additional hard-disk drives to any of the still-available SCSI ID numbers.
- If Dell installs additional SCSI hard-disk drives in the system, they will be configured as SCSI ID 1 and SCSI ID 2.

*NOTE: There is **no** requirement that SCSI ID numbers be assigned sequentially or that devices be attached to the cable in order by ID number.*

Device Termination

Before installing SCSI devices, you must configure the termination on the device(s) and for the built-in SCSI controller according to the guidelines listed in the following text.

SCSI logic requires that termination be enabled for the two devices at opposite ends of the SCSI chain and disabled for all devices in between. To that end, regardless of whether you are installing internal or external devices, use the following guidelines:

- The built-in SCSI controller has active termination—no action is required.
- Termination is set on the SCSI hard-disk drive installed in the left bay of the internal drive bays when the drive is installed by Dell. Termination should be disabled on any other drives installed in the internal bays. Figure 9-1 shows where the termination jumper should be located on the Dell-supplied 2-gigabyte (GB), 4-GB, and 9-GB SCSI hard-disk drives for the PowerEdge 2200 system.
- If you install an optional SCSI controller card to control the CD-ROM drive and any other SCSI device in the external bays, you must enable termination for the SCSI controller card and the SCSI device at the end of the interface cable (preferably the CD-ROM drive). See the documentation that came with your SCSI controller card for instructions. To enable termination for the CD-ROM drive, place a jumper on the pins on the back of the CD-ROM drive as shown in Figure 9-1.

CAUTION: When you install or remove termination jumpers, do not move or remove any other jumpers installed on the drives.

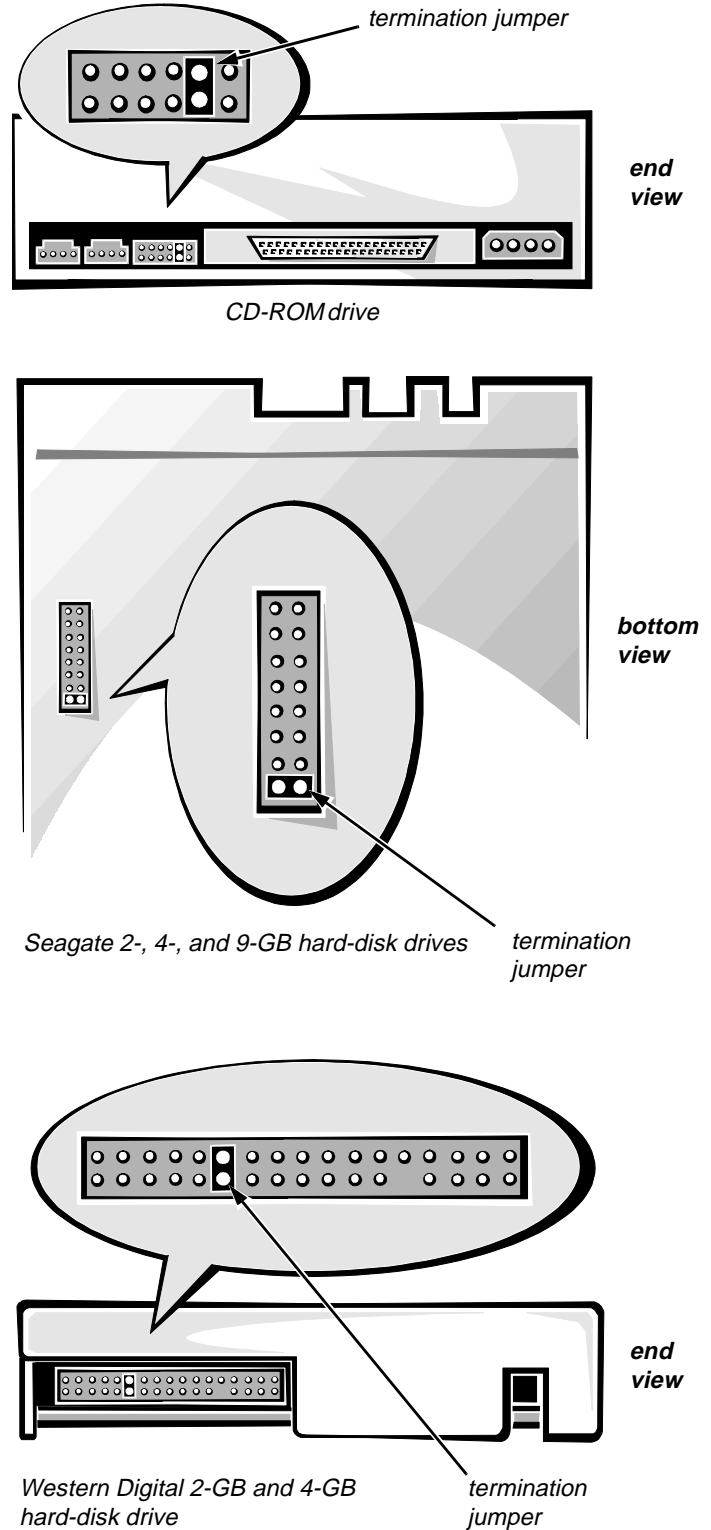

Figure 9-1. SCSI Termination Jumper Locations

Configuring the Boot Device

If you plan to boot your system from a hard-disk drive, the drive must be attached to the primary (or boot) controller or built-in SCSI controller. You can select as the primary controller either the built-in SCSI controller or an optional controller installed in an expansion slot through the Advanced menu in System Setup. Within the Advanced menu, the PCI Scan Sequence option allows you to select either the built-in SCSI controller or a controller in an expansion slot as the primary controller.

SCSI Cable

Figure 9-2 shows the SCSI cable provided with the Dell PowerEdge 2200 system. Figure 9-3 shows the SCSI cable installed in the Dell PowerEdge 2200 system.

CAUTION: Dell recommends that you use only SCSI cables purchased from Dell. SCSI cables purchased elsewhere are not guaranteed to work reliably with PowerEdge 2200 systems.

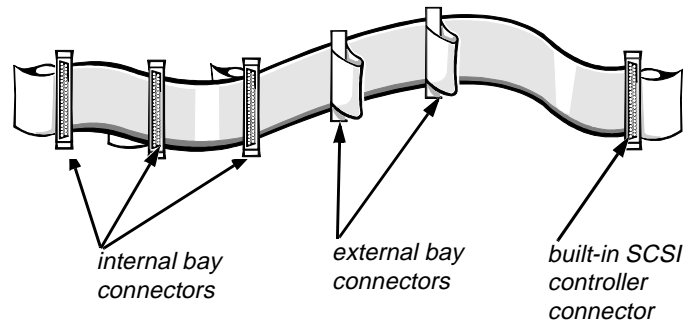

Figure 9-2. SCSI Interface Cable

The cable shown in Figure 9-2 has six 68-pin connectors:

- The connector at one end of the cable farthest from the other connectors attaches to the SCSI controller connector (SCSI) on the system board.
- The two connectors in the middle of the cable attach to SCSI devices in the external drive bays via 68-pin to 50-pin adapters.
- The three connectors at the other end of the cable attach to the drives in the internal hard-disk drive cage. The connector on the end of the cable should be attached to the leftmost drive in the internal hard-disk drive cage since the termination jumpers on this drive can be accessed without removing the drive cage.

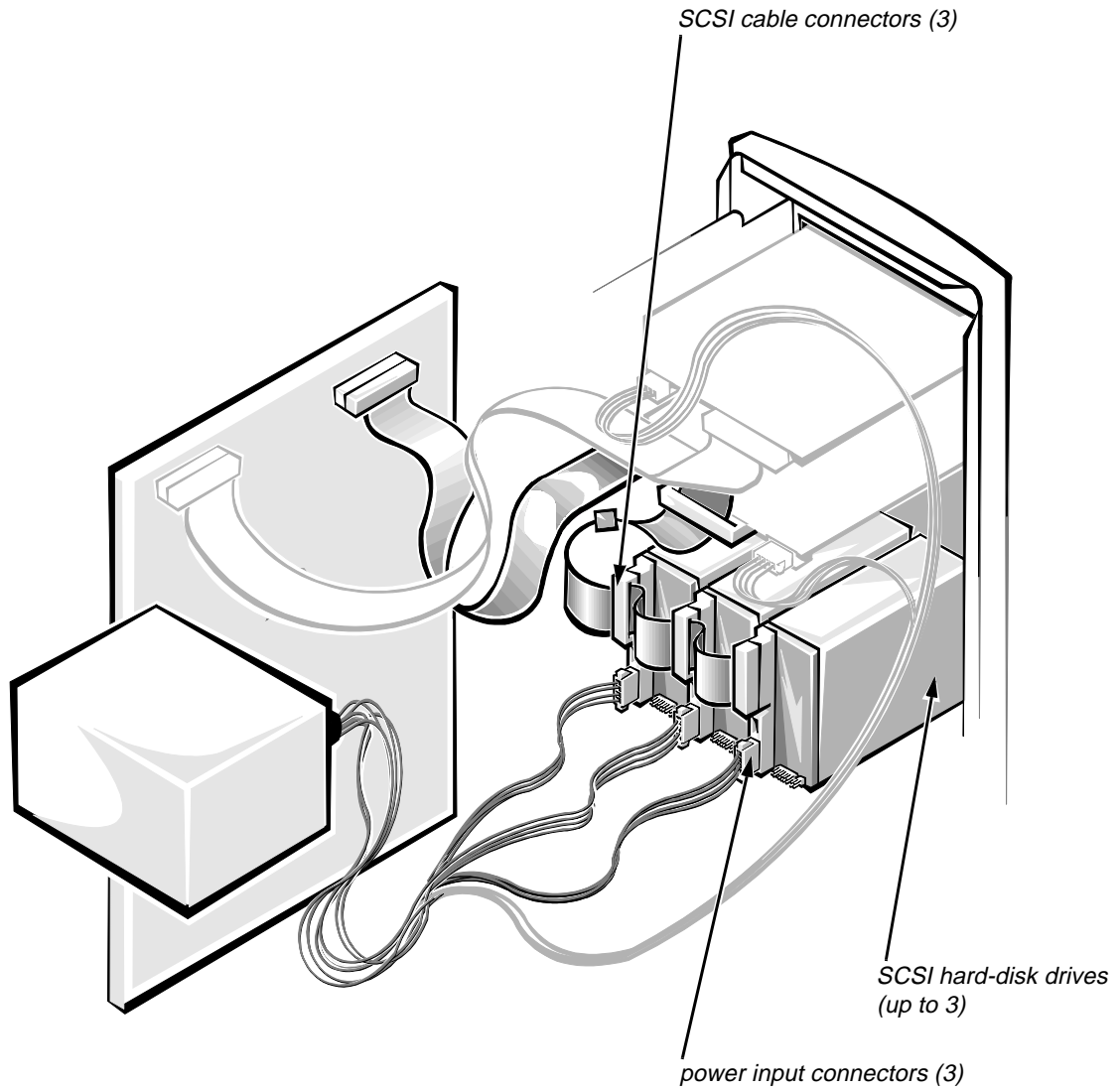

Figure 9-3. SCSI Cable for a PowerEdge 2200 System

Installing SCSI Hard-Disk Drives in the Internal Bays

Configure and install SCSI hard-disk drives in your computer's internal drive bays as follows:

1. **Determine where your SCSI drive(s) will be installed and which connector on the SCSI cable you will attach to each of them.**

See "SCSI Cable" found earlier in this chapter.

2. **Unpack each SCSI drive, and prepare it for installation.**

Configure each drive for a SCSI ID number, and enable the termination, if necessary. For instructions, see the documentation that came with the SCSI drive as well as "SCSI Configuration Guidelines" found earlier in this chapter. For instructions on configuring the drive as a boot device, see "Configuring the Boot Device" found earlier in this chapter.

3. **Remove the computer cover and front bezel according to the instructions in "Removing the Computer Cover" and "Removing the Front Bezel" in Chapter 6.**

CAUTION: See "Protecting Against Electrostatic Discharge" in the safety instructions at the front of this guide.

4. **Lay the computer on its right side for easy access to the internal hard-disk drive cage and the expansion card slots.**
5. **Disconnect the interface cables and power cables from any hard-disk drives already installed in the hard-disk drive cage.**
6. **Remove the four mounting screws that secure the hard-disk drive cage to the chassis (Figure 9-4).**
7. **Remove the hard-disk drive cage from the chassis.**

Slide the hard-disk drive cage toward the back of the chassis until the tabs on the hard-disk drive cage release from the guide rails on the bottom of the upper drive cage. Then lift the hard-disk drive cage up and out of the chassis.

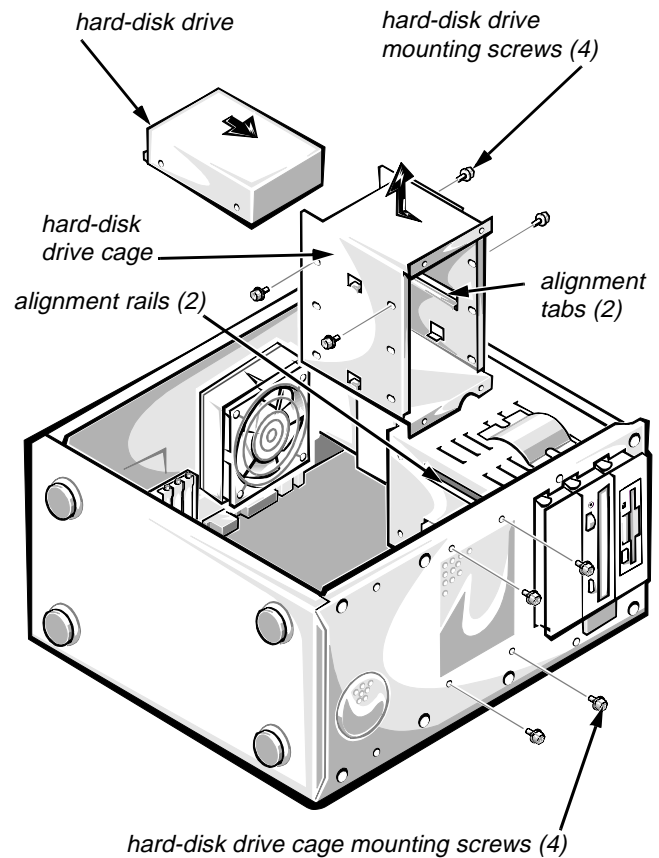

Figure 9-4. Removing the Hard-Disk Drive Cage

8. **If you are installing a SCSI controller card, configure the card. Then install it in one of the expansion slots.**

For instructions on configuring the SCSI controller card, see the documentation for the card. For instructions on installing the card, see "Installing an Expansion Card" in Chapter 7.

9. Install the SCSI drive(s) in the hard-disk drive cage.

Slide the drive into the cage, align the drive's mounting-screw holes with the holes in the drive cage, and secure the drive with four screws (see Figure 9-5).

NOTE: The screws provided with drives purchased from Dell include special screws with shallow heads. Screws with larger heads may make it difficult to reinstall the hard-disk drive cage.

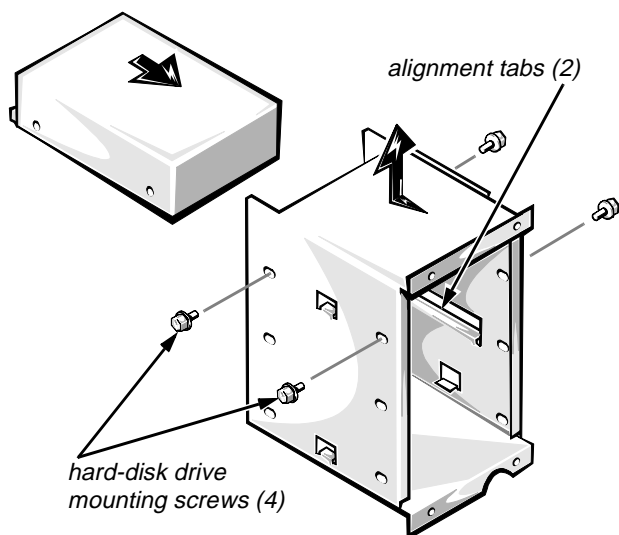

Figure 9-5. Installing a Hard-Disk Drive in the Drive Cage

10. Reinstall the hard-disk drive cage in the chassis (see Figure 9-4).

Align the tabs on the drive cage with the rails on the bottom of the upper drive cage, and then slide the drive cage into position. Secure the drive cage with the four mounting screws that you removed in step 6.

11. Attach a direct current (DC) power cable connector to the power input connector on each SCSI drive.

See “DC Power Cables” in Chapter 8 for instructions on which DC power cable to use.

12. Attach the SCSI cable to each SCSI drive.

For general cabling guidelines, see “SCSI Cable” found earlier in this chapter.

For each drive, firmly press one of the cable's connectors onto the 68-pin connector on the back of the drive.

Match the colored strip on the SCSI cable to the pin-1 side of the connector on the drive. (The connectors are shaped so that they cannot be inserted the wrong way.)

13. Attach the SCSI cable to the appropriate connector on the SCSI controller card or to the built-in SCSI host adapter connector (SCSI) on the system board.

If you are using the built-in SCSI host adapter, its connector (SCSI) is near the top of the system board. If you are using a SCSI controller card, see the documentation that came with the controller card.

Align the colored edge of the cable with the pin-1 end of the SCSI connector on the system board or SCSI controller card. The cable and connector are also aligned by a key on the cable end and a notch in the connector shroud. Press the connectors together firmly.

14. Replace the computer cover and front bezel according to the instructions in “Replacing the Computer Cover” and “Replacing the Front Bezel” in Chapter 6.

15. Then reconnect the computer and peripherals to their power sources, and turn them on.

16. Install any required SCSI device drivers.

For information on installing the appropriate drivers and preparing your SCSI hard-disk drive for use, see Chapter 3, “Installing and Configuring SCSI Drivers.”

17. Test the SCSI drives.

Run the SCSI Devices Test Group of the system diagnostics. See Chapter 2, “Using the Dell Server Assistant CD,” for information on running the system diagnostics from the *Dell Server Assistant CD*. See the chapter titled “Running the Diskette-Based Diagnostics” in your *Diagnostics and Troubleshooting Guide* for information on the SCSI Devices Test Group.

Appendix A

Technical Specifications

Table A-1. Technical Specifications

Microprocessor	
Microprocessor types	single or dual Pentium II microprocessor with an internal operating frequency of 233 or 266 MHz and an external operating frequency of 66 MHz
Internal cache	32-KB L1 cache, 512-KB L2 cache
Math coprocessor	internal to microprocessor
Expansion Bus	
Bus type	EISA, PCI local bus
Expansion slots	three full-length, 8- or 16-bit ISA or 32-bit EISA; three full-length, 32-bit PCI
Memory	
DIMM sockets	four 168-pin sockets
DIMM capacities	32 and 128 MB (DIMMs are 60 ns or faster, buffered EDO)
Standard RAM (minimum).	32 MB
Maximum RAM	512 MB
External cache.	none

NOTE: For the full name of an abbreviation or acronym used in this table, see the Glossary.

Table A-1. Technical Specifications (continued)

Drives	
Diskette drive	one 3.5-inch, 1.44-MB diskette drive included with standard system
Tape drive	capacities ranging from 4 GB to 24 GB (when available)
SCSI hard-disk drives	formatted capacities ranging from 2 GB to 9 GB
SCSI devices	built-in SCSI controller supports up to three SCSI hard-disk drives in internal bays and up to two SCSI devices in externally accessible front bays
CD-ROM drive	one CD-ROM drive included with standard system
Ports	
Externally accessible:	
Serial	two 9-pin connectors
Parallel (bidirectional)	one 25-pin connector
Video	one 15-pin connector
PS/2-style keyboard	6-pin mini-DIN
PS/2-compatible mouse	6-pin mini-DIN
Internally accessible:	
Ultra/Wide SCSI controller	68-pin connector
Diskette drive	34-pin connector
Video	
Video type	ATI mach64 (264VT) PCI video controller; VGA connector
Video memory (standard)	1 MB

NOTE: For the full name of an abbreviation or acronym used in this table, see the Glossary.

Table A-1. Technical Specifications (continued)

Power	
DC power supply:	
Wattage	230 W
Voltage	115 V at 60 Hz/230 V at 50 Hz
System battery	3.0-V lithium coin cell

Physical	
Height (with support feet)	44.45 cm (17.50 inches)
Width	24.13 cm (9.50 inches)
Depth	41.91 cm (16.50 inches)
Weight (minimum configuration) ...	17.68 kg (39.0 lb)

Environmental	
Temperature:	
Operating	10° to 35°C (50° to 95°F)
Storage	-40° to 65°C (-40° to 149°F)
Relative humidity	8% to 80% (noncondensing)

NOTE: For the full name of an abbreviation or acronym used in this table, see the Glossary.

Appendix B

Hardware Configuration Features

This appendix provides specific information about the jumpers on the system board, the connectors and sockets on the system board, and the input/output (I/O) ports and connectors on the back panel of the computer. It also provides some basic information on jumpers.

Jumpers

Jumpers provide a convenient and reversible way of reconfiguring the circuitry on a printed circuit board. When reconfiguring the system, you may need to change jumper settings on the system board; you may also need to change jumper settings on expansion cards or on drives.

A jumper is a small block on the system board with two or more pins emerging from it.



A plastic plug containing a wire fits down over the pins. The wire connects the pins and creates a circuit.



To change a jumper setting, pull the plug off its pin(s) and carefully fit it down onto the pin(s) indicated.

CAUTION: Make sure your system is turned off before you change a jumper setting. Otherwise, damage to your system or unpredictable results may occur.

A jumper is referred to as *open* or *unjumpered* when the plug is pushed down over only one pin or if there is no plug at all. When the plug is pushed down over two pins, the jumper is referred to as *jumpered*. The jumper setting is often shown in text as two numbers, such as 1-2. The number 1 is printed on the circuit board so that you can identify each pin number based on the location of pin 1.

Figure B-1 shows the location and default settings of the jumper blocks on the system board. See Table B-1 for the designations, default settings, and functions of the system board's jumpers.

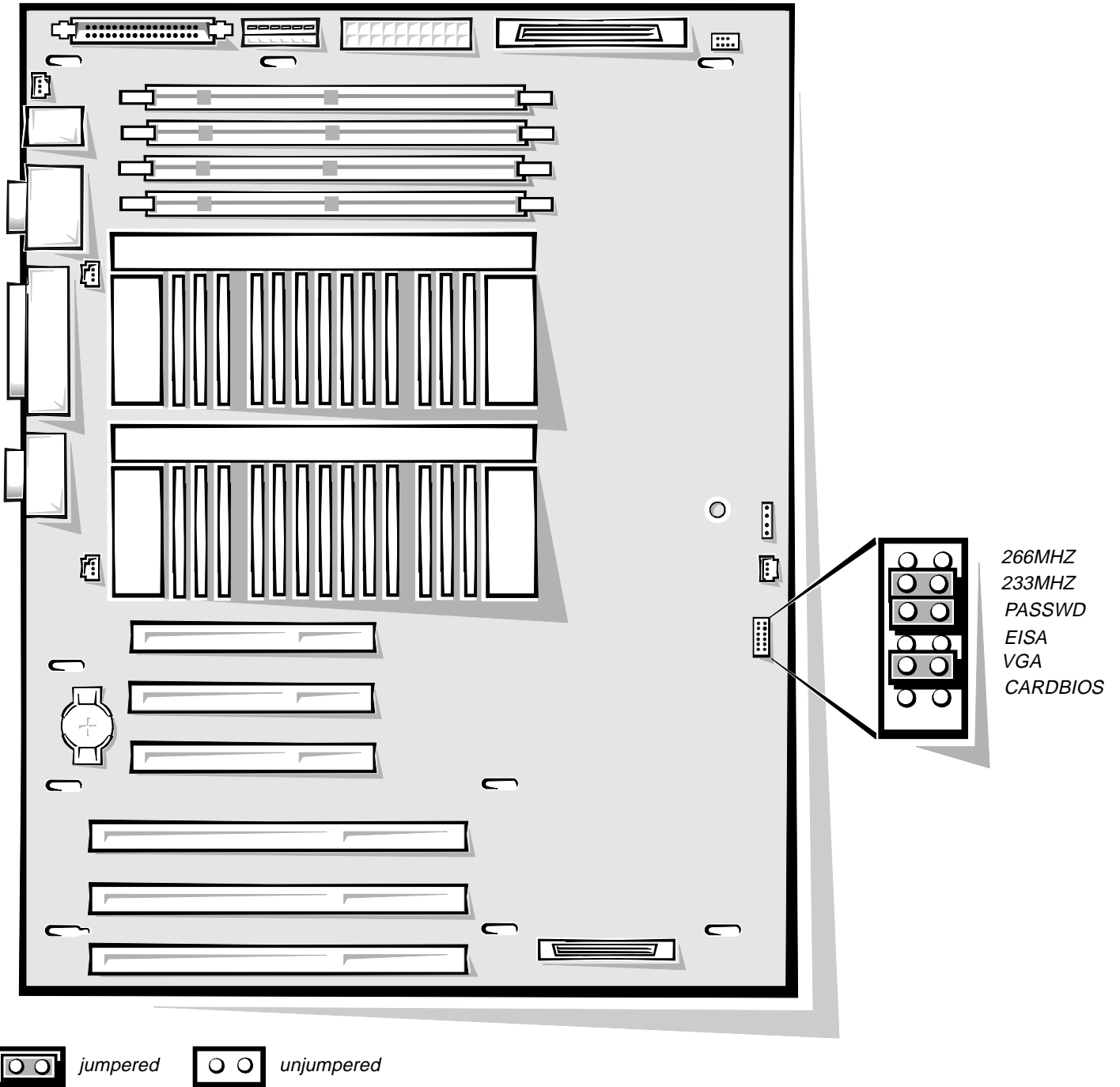













Figure B-1. System Board Jumpers

Table B-1. System Board Jumpers

Jumper	Setting	Default	Description
CARDBIOS		Default	System boots normally.
			System boots from a BIOS expansion card. Used for troubleshooting.
VGA		Default	The built-in video subsystem is enabled.
			The built-in video subsystem is disabled.
EISA		Default	The EISA Configuration Utility settings are retained at system boot.
			The EISA Configuration Utility settings are cleared at next system boot. (If the EISA Configuration Utility becomes corrupted to the point where the system will not boot, install the jumper and boot the system. Remove the jumper before restoring the EISA configuration information.)
PASSWD		Default	Boot password features are enabled.
			Boot password features are disabled.
266MHZ			Jumpered when the microprocessor's internal operating frequency is 266 MHz.
			Unjumpered when the microprocessor's internal operating frequency is 233 MHz.
233MHZ			Jumpered when the microprocessor's internal operating frequency is 233 MHz.
			Unjumpered when the microprocessor's internal operating frequency is 266 MHz.

NOTE: For the full name of an abbreviation or acronym used in this table, see the Glossary.



jumpered



unjumpered

Connectors and Sockets

Table B-2 lists the connectors and sockets located on the system board and gives a brief description of their functions.

Table B-2. Connectors and Sockets on the System Board

Connector or Socket	Description
AUXFAN	Fan connector (reserved for an auxiliary fan)
BATTERY	Battery socket
DIMM_x	DIMM socket
EISA _n	EISA expansion-card connector
FAN	Fan connector (microprocessor cooling fan)
FLOPPY	Diskette controller connector
HDLED	Hard-disk drive access indicator connector
JVGA	Video connector
KYBD/MOUSE	Keyboard and mouse connectors
PANEL	Front-panel connector
PARALLEL	Parallel port connector; sometimes referred to as <i>LPT1</i>
PCI _n	PCI expansion-card connector
POWER	Power input connector
POWER3V	Three-volt power input connector
PROC_1	Primary microprocessor module
PROC_2	Secondary microprocessor module
SCSI	Integrated SCSI host adapter connector
SERIAL	Serial port connectors; sometimes referred to as <i>COM1</i> and <i>COM2</i>
SVR_MGT	Server management connector
TEMP_1	Primary microprocessor temperature sensor connector
TEMP_2	Secondary microprocessor temperature sensor connector

NOTE: For the full name of an abbreviation or acronym used in this table, see the Glossary.

I/O Ports and Connectors

The I/O ports and connectors on the back panel of the computer are the gateways through which the computer system communicates with external devices, such as a keyboard, mouse, printer, and monitor. Figure B-2 identifies the I/O ports and connectors for your system.

Serial and Parallel Ports

The two built-in serial ports use 9-pin D-subminiature connectors on the back panel. These ports support devices such as external modems, printers, plotters, and mice that require serial data transmission (the transmission of data one bit at a time over one line).

Most software uses the term *COM* (for *COM*munications) plus a number to designate a serial port (for example, *COM1* or *COM2*). The default designations of your computer's built-in serial ports are *COM1* and *COM2*. *COM1* is the bottom connector; *COM2* is on the top.

The built-in parallel port uses a 25-pin D-subminiature connector on the computer's back panel. This I/O port sends data in parallel format (where eight data bits, or one byte, are sent simultaneously over eight separate lines in a single cable). The parallel port is used primarily for printers.

Most software uses the term *LPT* (for *Line PrinTer*) plus a number to designate a parallel port (for example, *LPT1*). The default designation of the computer's built-in parallel port is *LPT1*.

Port designations are used, for example, in software installation procedures that include a step in which you identify the port to which a printer is attached, thus telling the software where to send its output. (An incorrect designation prevents the printer from printing or causes scrambled print.)

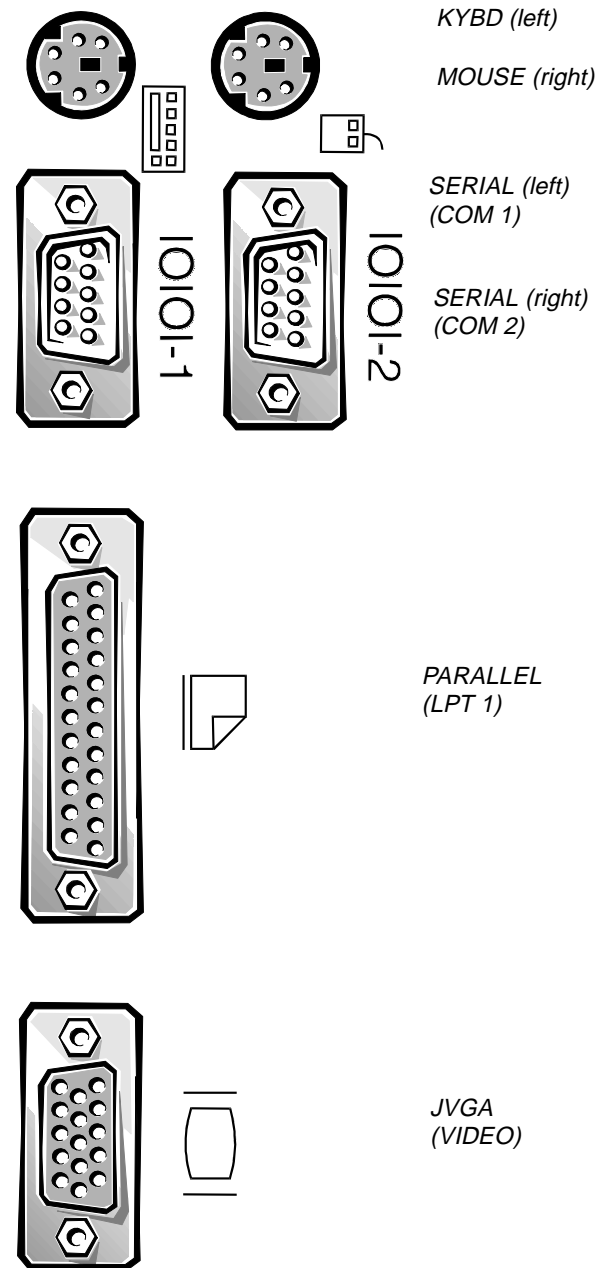

Figure B-2. I/O Ports and Connectors

Adding an Expansion Card Containing Serial or Parallel Ports

The computer system has an autoconfiguration capability for the serial ports. This feature lets you add an expansion card containing a serial port that has the same designation as one of the built-in ports, without having to reconfigure the card. When the computer detects the duplicate serial port on the expansion card, it *remaps* (reassigns) the built-in port to the next available port designation.

Both the new and the remapped COM ports share the same interrupt request (IRQ) setting, as follows:

COM1, COM3: IRQ4 (shared setting)

COM2, COM4: IRQ3 (shared setting)

These COM ports have the following I/O address settings:

COM1: 3F8h

COM2: 2F8h

COM3: 3E8h

COM4: 2E8h

For example, if you add an internal modem card with a port configured as COM1, the computer then sees logical COM1 as the address on the modem card. It automatically remaps the built-in serial port that *was* designated as COM1 to COM3, which shares the COM1 IRQ setting. (Note that when you have two COM ports sharing an IRQ setting, you can use either port as necessary, *but you may not be able to use them both at the same time.*) If you install one or more expansion cards with serial ports designated as COM1 and COM3, the corresponding built-in serial port is disabled, as described in “Serial Port 1” and “Serial Port 2” in Chapter 4.

Before adding a card that remaps the COM ports, check the documentation that accompanied your software to make sure that the software can be mapped to the new COM port designation.

To avoid autoconfiguration, you may be able to reset jumpers on the expansion card so that *its* port designation changes to the next available COM number, leaving the designation for the built-in port as is. Alternatively, you can disable the built-in ports through the System Setup program. The documentation for your expansion card should provide the card's

default I/O address and allowable IRQ settings. It should also provide instructions for readdressing the port and changing the IRQ setting if necessary.

The built-in parallel port has autoconfiguration capability through the System Setup program. That is, if you set the parallel port to its automatic configuration and add an expansion card containing a port configured as LPT1 (IRQ7, I/O address 378h), the system automatically remaps the built-in parallel port to its secondary address (IRQ5, I/O address 278h). If the secondary port address is already being used, the built-in parallel port is turned off. For more information, see “Parallel Port” in Chapter 4.

For general information on how your operating system handles serial and parallel ports as well as for more detailed command procedures, see your operating system documentation.

Serial Port Connectors

If you reconfigure your hardware, you may need pin number and signal information for the serial port connectors. Figure B-3 illustrates the pin numbers for the serial port connectors, and Table B-3 lists and defines the pin assignments and interface signals for the serial port connectors.

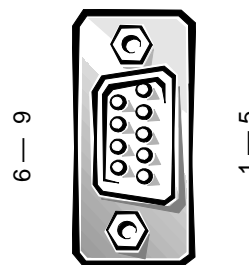

Figure B-3. Pin Numbers for the Serial Port Connectors

Table B-3. Pin Assignments for the Serial Port Connectors

Pin	Signal	I/O	Definition
1	DCD	I	Data carrier detect
2	SIN	I	Serial input
3	SOUT	O	Serial output
4	DTR	O	Data terminal ready
5	GND	N/A	Signal ground
6	DSR	I	Data set ready
7	RTS	O	Request to send
8	CTS	I	Clear to send
9	RI	I	Ring indicator
Shell	N/A	N/A	Chassis ground

Table B-4. Pin Assignments for the Parallel Port Connector

Pin	Signal	I/O	Definition
1	STB#	I/O	Strobe
2	PD0	I/O	Printer data bit 0
3	PD1	I/O	Printer data bit 1
4	PD2	I/O	Printer data bit 2
5	PD3	I/O	Printer data bit 3
6	PD4	I/O	Printer data bit 4
7	PD5	I/O	Printer data bit 5
8	PD6	I/O	Printer data bit 6
9	PD7	I/O	Printer data bit 7
10	ACK#	I	Acknowledge
11	BUSY	I	Busy
12	PE	I	Paper end
13	SLCT	I	Select
14	AFD#	O	Automatic feed
15	ERR#	I	Error
16	INIT#	O	Initialize printer
17	SLIN#	O	Select in
18-25	GND	N/A	Signal ground

Parallel Port Connector

If you reconfigure your hardware, you may need pin number and signal information for the parallel port connector. Figure B-4 illustrates the pin numbers for the parallel port connector, and Table B-4 lists and defines the pin assignments and interface signals for the parallel port connector.

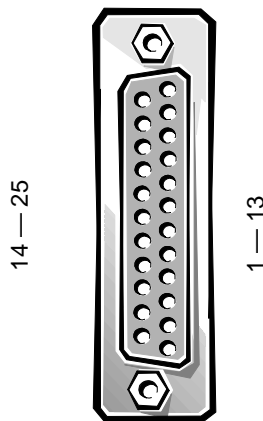

Figure B-4. Pin Numbers for the Parallel Port Connector

Keyboard and Mouse Connectors

The system uses a Personal System/2 (PS/2)-style keyboard and supports a PS/2-compatible mouse. Cables from both devices attach to 6-pin, miniature *Deutsche Industrie Norm* (DIN) connectors on the back panel of your computer. The keyboard connector is on the bottom; the mouse connector is on the top.

A PS/2-compatible mouse works identically to an industry-standard serial mouse or bus mouse except that it has its own dedicated connector, which frees up both serial ports and does not require an expansion card. Circuitry inside the

mouse detects the movement of a small ball and relays the direction to the computer.

Mouse driver software can give the mouse priority with the microprocessor by issuing IRQ12 whenever a new mouse movement is made. The driver software also passes along the mouse data to the application program that is in control.

Keyboard Connector

If you reconfigure your hardware, you may need pin number and signal information for the keyboard connector. Figure B-5 illustrates the pin numbers for the keyboard connector, and Table B-5 lists and defines the pin assignments and interface signals for the keyboard connector.

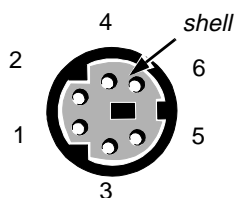

Figure B-5. Pin Numbers for the Keyboard Connector

Table B-5. Pin Assignments for the Keyboard Connector

Pin	Signal	I/O	Definition
1	KBDATA	I/O	Keyboard data
2	NC	N/A	No connection
3	GND	N/A	Signal ground
4	FVcc	N/A	Fused supply voltage
5	KBCLK	I/O	Keyboard clock
6	NC	N/A	No connection
Shell	N/A	N/A	Chassis ground

Mouse Connector

If you reconfigure your hardware, you may need pin number and signal information for the mouse connector. Figure B-6 illustrates the pin numbers for the mouse connector, and Table B-6 lists and defines the pin assignments and interface signals for the mouse connector.

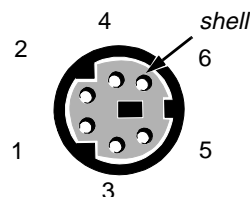

Figure B-6. Pin Numbers for the Mouse Connector

Table B-6. Pin Assignments for the Mouse Connector

Pin	Signal	I/O	Definition
1	MFDATA	I/O	Mouse data
2	NC	N/A	No connection
3	GND	N/A	Signal ground
4	FVcc	N/A	Fused supply voltage
5	MFCLK	I/O	Mouse clock
6	NC	N/A	No connection

Video Connector

The system uses a 15-pin high-density D-subminiature connector on the back panel for attaching a video graphics array (VGA)-compatible monitor to your computer. The video circuitry on the system board synchronizes the signals that drive the red, green, and blue electron guns in the monitor.

NOTE: Installing a video card automatically disables the system's built-in video subsystem.

If you reconfigure your hardware, you may need pin number and signal information for the video connector. Figure B-7 illustrates the pin numbers for the video connector, and Table B-7 lists and defines the pin assignments and interface signals for the video connector.

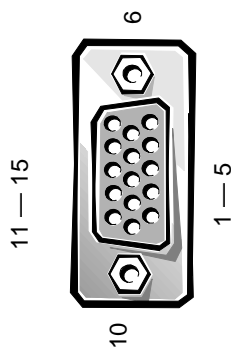

Figure B-7. Pin Numbers for the Video Connector

Table B-7. Pin Assignments for the Video Connector

Pin	Signal	I/O	Definition
1	RED	O	Red video
2	GREEN	O	Green video
3	BLUE	O	Blue video
4	NC	N/A	No connection
5-8, 10	GND	N/A	Signal ground
9	DDC	N/A	Vcc
11	NC	N/A	No connection
12	DDC data out	O	Monitor detect data
13	HSYNC	O	Horizontal synchronization
14	VSYNC	O	Vertical synchronization
15	DDC clock out	O	Monitor detect clock
Shell	N/A	N/A	Chassis ground

Appendix C

Maintaining the System

Proper use of preventive maintenance procedures can keep the system in top operating condition and minimize the need for costly, time-consuming service procedures. This appendix contains maintenance procedures that you should perform regularly.

Data Preservation

Everyone inadvertently deletes files at one time or another. Also, hard-disk drives can fail after extended use, so it is not a question of *whether* you will eventually lose data, but *when*. To avoid such loss of data, you should regularly make backup copies of all hard-disk drive files. Frequent, regular backups are a must for anyone using a hard-disk drive.

Scheduling Backups

The frequency with which backups should be made depends on the amount of storage space on a hard-disk drive and the volatility of the data contained on the drive. Heavily used systems require more frequent backups than systems in which files are seldom changed.

Dell recommends that you back up the hard-disk drive at least once a week, with a daily backup of those files known to have been changed. Following these guidelines ensures the loss of no more than a day's work in the event of a hard-disk drive failure or if you inadvertently delete one or more important files.

As further insurance against data losses, you should keep duplicate copies of the weekly and monthly backups at an off-site location. Doing this ensures that you lose no more than a week's work, even if one of the on-site backups becomes corrupted.

Backup Devices

Tape drives are fast, convenient, and affordable devices that can back up data at rates of up to 1.6 megabytes per second (MB/sec) (sustained, with data compression) and can often run unattended. Dell offers tape drives with storage capacities in the range of 4 to 24 gigabytes (GB) (when available) per tape cartridge and recommends these drives and their associated backup software for use as system backup devices.

As a last resort, you can back up a hard-disk drive's contents on diskettes, a method that is both time-consuming and prone to human error. Also, backing up a full 120-MB hard-disk drive requires approximately 83 diskettes (when using 1.44-MB diskettes), 100 diskettes (when using 1.2-MB diskettes), or 42 diskettes (when using 2.88-MB diskettes). Therefore, if it is absolutely necessary to use diskettes as backup devices, any unwanted hard-disk drive files should be deleted before a backup procedure is started.

Recovering Data

Some hard-disk drive failures are recoverable. In these cases you may be able to recover all lost data if the proper utility software is available. Even losses such as accidentally deleted files or accidental reformatting of a hard-disk drive can be reversed with these utilities.

If the computer system is running MS-DOS, many apparent data loss problems are due to corruption or erasure of the hard-disk drive's master boot record (MBR), MS-DOS boot sector, or file allocation table (FAT). That is, accidental deletion of files or accidental reformatting of the hard-disk drive alters the MS-DOS boot sector, the FAT, and the root directory.

However, such accidents do not actually erase the contents of the hard-disk drive files until new data is written

to the sectors containing these files. With software such as the Norton Utilities, Mace Utilities, or PC-Tools Deluxe, the data stored in these areas can often be restored, meaning that you can recover most, if not all, of the data.

Unlike using the **format** command on a hard-disk drive, using **format** on a diskette completely erases all the data on the diskette unless you use the diskette **format** program included in the Mace Utilities.

For a complete description of data recovery procedures and the software needed to perform them, see *The Paul Mace Guide to Data Recovery*, published by Brady.

Cleaning System Components

An exhaust fan in the power supply cools the power supply and computer by drawing air in through various openings in the computer and blowing it out the back. However, the fan also draws dust and other particles into the computer, causing contaminant buildup, which results in an increase in the system's internal temperature and interferes with the operation of various system components.

To avoid these conditions, Dell recommends keeping your work environment clean to reduce the amount of dust and dirt around the computer, thereby reducing the amount of contaminants drawn into the computer by the power supply fan. In particular, you should keep the exterior of your computer and monitor clean, and you should use a commercially available diskette-drive head-cleaning kit to remove contaminants inside your diskette drives.

Recommended Tools and Accessories

Dell recommends that you use the following tools and accessories when you clean the computer:

- *A wrist grounding strap* — The proper use of a wrist grounding strap reduces the effect of electrostatic discharge (ESD), which can damage certain computer components. To use a wrist grounding strap, place the strap around your wrist and attach the other end of the strap to an unpainted metal surface in the chassis, such as the power supply bracket, that is connected to chassis ground.

- *A liquid dishwashing detergent* — Use a mixture of one part liquid dishwashing detergent and three parts water to clean the exterior of the computer, monitor, and keyboard. You can also add fabric softener to produce an antistatic solution that prevents dust from being attracted to the monitor screen.
- *A soft, lint-free cleaning cloth* — Moisten the cleaning cloth with the dishwashing detergent solution to clean the exterior of the computer system.
- *A nonabrasive diskette-drive head-cleaning kit* — Dell recommends that you use a kit that contains pre-treated diskettes in individually sealed packages. These kits ensure that the cleaning solution is applied evenly over the entire diskette-drive head surface, and they prevent contamination of the heads by exposure to foreign substances.
- *A small vacuum cleaner with a brush attachment* — Use the vacuum cleaner to remove dust and dirt from the exterior of the computer and keyboard.

Cleaning the Computer, Monitor, and Keyboard Exteriors

A conventional monitor or keyboard cover minimizes the accumulation of dust and other debris inside the monitor and keyboard when they are not in use. Also, commercially available keyboard membrane covers make it possible to use the keyboard while providing protection against foreign particles.

However, regardless of any protective covers, the monitor and keyboard must be cleaned occasionally. To clean the exterior of the computer, monitor, and keyboard, follow these steps:

1. **Turn off the computer, monitor, and any other attached peripherals, and disconnect them from their power sources.**
2. **Use a vacuum cleaner to remove any dust from the slots and holes on the computer and between the keys on the keyboard.**
3. **Moisten a soft cleaning cloth with a solution of three parts water and one part liquid dishwashing detergent.**

Do not soak the cloth in the solution; you must not let the solution drip inside the computer or keyboard.

4. Use the moistened cloth to wipe the computer cover, the keyboard, and the exterior of the monitor, including the screen.

Cleaning Drives

You can clean the heads of your diskette drives by using a commercially available diskette-drive head-cleaning kit. These kits include diskettes pretreated with a chemical solution to nonabrasively remove contaminants that accumulate on the drive heads during normal operation.

If the kit does not contain instructions, insert one of the pretreated diskettes into a diskette drive and turn on the system. After 20 or 30 seconds, remove the diskette from the drive. Repeat this procedure for each diskette drive in the computer.

CAUTION: Do not attempt to clean drive heads with a swab. You may accidentally misalign the heads, rendering the drive inoperable.

Environmental Factors

This section discusses various environmental factors that can adversely affect system performance and longevity.

Temperature

Temperature extremes can cause a variety of problems, including premature aging and failure of chips or mechanical failure of devices. Extreme temperature fluctuations can cause chips to become loose in their sockets and can cause expansion and contraction of disk drive platters, resulting in read or write data errors. When you perform a low-level format operation on a hard-disk drive, it is important to ensure that the drive's surrounding temperature is at or near the temperature at which the drive will be operated. Failure to do so can result in relocation of the tracks on the disk platters.

To minimize the negative effects of temperature on system performance, follow these guidelines:

- Ensure that the system is operated in an environment no colder than 10° Celsius (C) (50° Fahrenheit [F]) or hotter than 35°C (95°F).

- Ensure that the system has adequate ventilation. Do not place it within a closed-in wall unit or on top of cloth material, which can act as insulation. Do not place it where it will receive direct sunlight, particularly in the afternoon. Do not place it next to a heat source of any kind, including heating vents during winter

Adequate ventilation is particularly important at high altitudes. System performance may not be optimum when the system is operating at high temperatures as well as high altitudes.

- Make sure that all slots and openings on the computer remain unobstructed, especially the fan vent on the back of the computer.
- Clean the system at regular intervals to avoid any buildup of dust and debris, which can cause a system to overheat.
- If the system has been exposed to abnormally cold temperatures, allow a two-hour warm-up period to bring it up to normal operating temperature before turning it on. Failure to do so may cause damage to internal components, particularly the hard-disk drive.
- If intermittent system failures are noticed, try reseating any socketed chips, which might have become loose due to temperature fluctuations.

Humidity

High-humidity conditions can cause moisture migration and penetration into the computer. This moisture can cause corrosion of internal components and degradation of properties such as electrical resistance, thermal conductivity, physical strength, and size. Extreme moisture buildup inside the computer can result in electrical shorts, which can cause serious damage to the computer.

Each Dell system is rated to operate at 20 to 80 percent relative humidity, with a humidity gradation of 10 percent per hour. In storage, a Dell system can withstand from 5 to 95 percent relative humidity.

Buildings in which climate is controlled by air-conditioning in the warmer months and by heat during the colder months usually maintain an acceptable level of humidity for computer equipment. However, if a system is located in an unusually humid location, a dehumidifier can be used to maintain the humidity within an acceptable range.

Altitude

Operating a system at high altitude (low pressure) reduces the efficiency of forced and convection cooling and can result in electrical problems related to arcing and corona effects. This condition can also cause sealed components with internal pressure, such as electrolytic capacitors, to fail or perform at reduced efficiency.

Each Dell system is rated to operate at altitudes from –16 to 3048 meters (m) (–50 to 10,000 feet [ft]) and can be stored at altitudes of –16 to 10,600 m (–50 to 35,000 ft).

Dust and Particles

A clean operating environment can greatly reduce the negative effects of dust and other particles, which act as insulators and interfere with the operation of a system's mechanical components. Also, in addition to regular cleaning, you should follow these guidelines to deter contamination of the computer equipment:

- Do not permit smoking anywhere near the system.
- Do not permit food or drink near the system.
- Use dust covers when the system is not in use.
- Keep 5.25-inch diskettes in their paper sleeves, and keep all diskettes in a closed diskette box when not in use.
- Close windows and outside doors to keep out airborne particles.

Corrosion

The oil from a person's fingers or prolonged exposure to high temperature or humidity can corrode the gold-plated edge connectors and pin connectors on various devices in the computer. This corrosion on computer connectors is a gradual process that can eventually lead to intermittent failures of electrical circuits.

To prevent corrosion, you should avoid touching contacts on boards and cards. Protecting the system from corrosive elements is especially important in moist and salty environments, which tend to promote corrosion. Also, as a further deterrent to corrosion, the system should not be used in extreme temperatures, as explained in "Temperature" found earlier in this appendix.

ESD

ESD results from the buildup of static electricity on the human body and certain other objects. This static electricity is often produced by simple movements such as walking across a carpet. ESD is a discharge of a static electrical charge, which occurs when a person whose body contains such a charge touches a component in the computer. This static discharge can cause components, especially chips, to fail. ESD is a problem particularly in dry environments where the relative humidity is below 50 percent. To reduce the effects of ESD, you should observe the following guidelines:

- When working inside the computer, wear a wrist grounding strap. If a wrist grounding strap is unavailable, touch an unpainted metal surface on the chassis periodically to neutralize any static charge.
- If at all possible, stand on a concrete floor while working inside the computer.
- Use an antistatic floor mat when working inside the computer.
- If it is necessary to work in a carpeted area, spray the carpet with an antistatic spray and allow it to dry before beginning to work inside the computer.
- Keep components in their antistatic packaging until they are installed.
- Avoid wearing clothing made of wool or synthetic materials.

Electromagnetic and Radio Frequency Interference

Electromagnetic interference (EMI) and radio frequency interference (RFI) from a computer can adversely affect devices such as radio and television (TV) receivers operating near the computer. Radio frequencies emanating from a computer system can also interfere with cordless and low-power telephones. Conversely, RFI from high-power telephones can cause spurious characters to appear on the system's monitor screen.

RFI is defined as any EMI with a frequency above 10 kilohertz (kHz). This type of interference can travel from the computer to other devices through the alternating current (AC) power cable and power source or through the air like transmitted radio waves. The Federal Communications Commission (FCC) publishes specific

regulations to limit the amount of EMI and RFI emitted by computing equipment. Each Dell system meets these FCC regulations.

To reduce the possibility of EMI and RFI, follow these guidelines:

- Operate the system only with the computer cover installed.
- Ensure that all expansion slots are covered either by a card-mounting bracket or by a metal filler bracket and that all drive bays have a drive and/or a metal insert installed. These brackets and metal inserts are available from Dell.
- Ensure that the screws on all peripheral cable connectors are securely fastened to their corresponding connectors on the back of the computer.
- Always use shielded cables with metal connector shells for attaching peripherals to the computer.

To prevent the possibility of RFI from a computer affecting TV reception, follow these guidelines:

- Keep any TV set at least 6 ft away from the computer system.
- Use cable TV when possible.
- Use a directional outdoor TV antenna.
- Attach line filters to the TV set.
- Use 75-ohm coaxial cable for the TV set rather than twin-lead antenna wire.
- If interference occurs, rotate the computer or the TV set 90 degrees.

Magnetism

Because they store data magnetically, diskettes and hard-disk drives are extremely susceptible to the effects of magnetism. Diskettes should never be stored near magnetic sources such as the following:

- Monitors
- TV sets
- Printers
- Telephones with real bells
- Fluorescent lights

Shock and Vibration

Excessive shock can damage the function, external appearance, and physical structure of a system. Each Dell system has been designed to operate properly after withstanding a minimum of six consecutively executed shock pulses in the positive and negative x, y, and z axes. Each shock pulse can measure up to 50 gravities (G) for up to 2 milliseconds (ms). In storage, the system can withstand shock pulses of 92 G for 2 ms.

Excessive vibration can cause the same problems as mentioned earlier for shock, as well as cause components to become loose in their sockets or connectors. Systems can be subject to significant vibration when being transported by vehicle or when operated in an environment with machinery that causes vibration.

Each Dell system, when operating, is designed to withstand 0.25 G (half-sine wave) at a sweep of 3 to 200 hertz (Hz) for 15 minutes. In storage, the system can withstand 0.5 G at 3 to 200 Hz for 15 minutes.

Power Source Interruptions

Computer systems are especially sensitive to variations in voltage supplied by the AC power source. Over-voltage, undervoltage, and transients (or *spikes*) can erase data from memory or even cause components to fail. To protect against these types of problems, power cables should always be properly grounded and one or both of the following methods should be used:

- Use one of the power protection devices described in the following section, "Power Protection Devices."
- Place the system on a dedicated power circuit (rather than sharing a circuit with other heavy electrical equipment). In general, do not allow the system to share a circuit with any of the following:
 - Kitchen appliances
 - Copier machines
 - Air conditioners
 - Vacuum cleaners
 - Space heaters
 - Power tools
 - Teletype machines
 - Adding machines

- Laser printers
- Facsimile machines
- Any other motorized equipment

Besides these appliances, the greatest threat to a system's supply of power are surges or blackouts caused by electrical storms. Whenever possible, turn off the computer and any peripherals and unplug them from their power sources during thunderstorms.

If a blackout occurs—even a temporary one—while the system is turned on, turn off the system immediately and disconnect it from its power source. Leaving the system on may cause problems when the power is restored; all other appliances left on in the area can create large voltage spikes that can damage the system.

Power Protection Devices

A number of devices are available that protect against power problems, such as power surges, transients, and power failures. The following subsections describe some of these devices.

Surge Protectors

Surge protectors are available in a variety of types and usually provide a level of protection commensurate with the cost of the device. Surge protectors prevent voltage spikes, such as those caused during an electrical storm, from entering a system through the AC power source. Surge protectors, however, do not offer protection against

brownouts, which occur when the voltage drops more than 20 percent below the normal AC line voltage level.

Line Conditioners

Line conditioners go beyond the overvoltage protection of surge protectors. Line conditioners keep a computer's AC power source voltage at a fairly constant level and, therefore, can handle brownouts. Because of this added protection, line conditioners cost more than surge protectors—up to several hundred dollars. However, these devices cannot protect against a complete loss of power.

Uninterruptible Power Supply

An uninterruptible power supply (UPS) offers the most complete protection against variations in power because it uses battery power to keep the system running when AC power is lost. The battery is charged by the AC power while it is available, so once AC power is lost, the battery can provide power to the system for a limited amount of time—from 15 minutes to an hour or so—depending on the UPS system.

UPS systems range in price from a few hundred dollars to several thousand dollars, with the more expensive units allowing you to run larger systems for a longer period of time when AC power is lost. UPS systems that provide only 5 minutes of battery power let you conduct an orderly shutdown of the system, but are not intended to provide continued operation. Surge protectors should be used with all UPS systems, and the UPS system should be Underwriters Laboratories (UL) safety-approved.

Appendix D

Regulatory Notices

FCC Notices (U.S. Only)

Most Dell computer systems are classified by the Federal Communications Commission (FCC) as Class B digital devices. However, the inclusion of certain options changes the rating of some configurations to Class A. To determine which classification applies to your computer system, examine all FCC registration labels located on the back panel of your computer, on card-mounting brackets, and on the cards themselves. If any one of the labels carries a Class A rating, your entire system is considered to be a Class A digital device. If *all* labels carry either the Class B rating or the FCC logo (FCC), your system is considered to be a Class B digital device.

Once you have determined your system's FCC classification, read the appropriate FCC notice. Note that FCC regulations provide that changes or modifications not expressly approved by Dell Computer Corporation could void your authority to operate this equipment.

A Notice About Shielded Cables: Use only shielded cables for connecting peripherals to any Dell device to reduce the possibility of interference with radio and television reception. Using shielded cables ensures that you maintain the appropriate FCC radio frequency emissions compliance (for a Class A device) or FCC certification (for a Class B device) of this product. For parallel printers, a cable is available from Dell Computer Corporation.

Class A

NOTE: This equipment generates, uses, and can radiate radio frequency energy and, if not installed and used in accordance with the manufacturer's instruction manual, may cause harmful interference with radio communications. This equipment has been tested and found to

comply with the limits for a Class A digital device pursuant to Part 15 of the FCC Rules. These limits are designed to provide reasonable protection against harmful interference when the equipment is operated in a commercial environment. Operation of this equipment in a residential area is likely to cause harmful interference, in which case you will be required to correct the interference at your own expense.

Class B

NOTE: This equipment generates, uses, and can radiate radio frequency energy and, if not installed and used in accordance with the manufacturer's instruction manual, may cause interference with radio and television reception. This equipment has been tested and found to comply with the limits for a Class B digital device pursuant to Part 15 of the FCC Rules. These limits are designed to provide reasonable protection against harmful interference in a residential installation. However, there is no guarantee that interference will not occur in a particular installation. If this equipment does cause harmful interference with radio or television reception, which can be determined by turning the equipment off and on, you are encouraged to try to correct the interference by one or more of the following measures:

- Reorient the receiving antenna.
- Relocate the computer with respect to the receiver.
- Move the computer away from the receiver.
- Plug the computer into a different outlet so that the computer and the receiver are on different branch circuits.

If necessary, consult a representative of Dell Computer Corporation or an experienced radio/television technician for additional suggestions. You may find the following

booklet helpful: *FCC Interference Handbook, 1986*, available from the U.S. Government Printing Office, Washington, DC 20402, Stock No. 004-000-00450-7.

This device complies with Part 15 of the FCC Rules. Operation is subject to the following two conditions:

- This device may not cause harmful interference.
- This device must accept any interference received, including interference that may cause undesired operation.

The following information is provided on the device or devices covered in this document in compliance with FCC regulations:

- Product name: *Dell PowerEdge 2200*
- Model number: *SMS*
- Company name: Dell Computer Corporation
Regulatory Department
One Dell Way
Round Rock, Texas 78682 USA
512-338-4400

IC Notice (Canada Only)

Most Dell computer systems (and other Dell digital apparatus) are classified by the Industry Canada (IC) Interference-Causing Equipment Standard #3 (ICES-003) as Class B digital devices. To determine which classification (Class A or B) applies to your computer system (or other Dell digital apparatus), examine all registration labels located on the bottom or the back panel of your computer (or other digital apparatus). A statement in the form of “IC Class A ICES-3” or “IC Class B ICES-3” will be located on one of these labels.

Note that Industry Canada regulations provide that changes or modifications not expressly approved by Dell Computer Corporation could void your authority to operate this equipment.

This Class B (or Class A, if so indicated on the registration label) digital apparatus meets the requirements of the Canadian Interference-Causing Equipment Regulations.

Cet appareil numérique de la Classe B (ou Classe A, si ainsi indiqué sur l'étiquette d'enregistrement) respecte toutes les exigences du Règlement sur le Matériel Brouilleur du Canada.

EN 55022 Compliance (Czech Republic Only)

This device belongs to category B devices as described in EN 55022, unless it is specifically stated that it is a category A device on the specification label. The following applies to devices in category A of EN 55022 (radius of protection up to 30 meters). The user of the device is obliged to take all steps necessary to remove sources of interference to telecommunication or other devices.

Pokud není na typovém štítku počítače uvedeno, že spadá do třídy A podle EN 55022, spadá automaticky do třídy B podle EN 55022. Pro zařízení zařazená do třídy A (ochranné pásmo 30m) podle EN 55022 platí následující. Dojde-li k rušení telekomunikačních nebo jiných zařízení, je uživatel povinen provést taková opatření, aby rušení odstranil.

CE Notice

Marking by the symbol **CE** indicates compliance of this Dell system to the EMC (Electromagnetic Compatibility) directive of the European Community. Such marking is indicative that this Dell system meets or exceeds the following technical standards:

- EN 55022 — “Limits and Methods of Measurement of Radio Interference Characteristics of Information Technology Equipment.”

NOTE: EN 55022 emissions requirements provide for two classifications—Class A and Class B. If any

one of the registration labels (located on the bottom or back panel of your computer, on card-mounting brackets, or on the cards themselves) carries an FCC Class A rating, the following warning applies to your system.

WARNING: This is a Class A product. In a domestic environment this product may cause radio interference in which case the user may be required to take adequate measures.

- EN 50082-1 — “Electromagnetic compatibility— Generic immunity standard Part 1: Residential, commercial, and light industry.”
- IEC 801-2 — “Electromagnetic compatibility for industrial-process measurement and control equipment Part 2: Electrostatic discharge requirements.” — Severity level 3.
- IEC 801-3 — “Electromagnetic compatibility for industrial-process measurement and control equipment Part 3: Radiated electromagnetic field requirements.” — Severity level 2.
- IEC 801-4 — “Electromagnetic compatibility for industrial-process measurement and control equipment Part 4: Electrical fast transient/burst requirements.” — Severity level 2.
- EN60950:1992 + Amd.1:1993 + Amd.2:1993 — “Safety of Information Technology Equipment including Electrical Business Equipment.”

A “Declaration of Conformity” in accordance with the preceding standards has been made and is on file at Dell Products Europe BV, Limerick, Ireland.

VCCI Notices (Japan Only)

Most Dell computer systems are classified by the Voluntary Control Council for Interference (VCCI) as Class 2 information technology equipment (ITE). However, the inclusion of certain options changes the rating of some configurations to Class 1. To determine which classification applies to your computer system, examine the FCC classification on the registration labels located on the back panel of your computer, on card-mounting brackets, and on the cards themselves. If any one of the labels

carries an FCC Class A designation, your entire system is considered to be VCCI Class 1 ITE. If *all* labels carry either an FCC Class B identification number or the FCC logo (FCC), your system is considered to be VCCI Class 2 ITE.

Once you have determined your system’s VCCI classification, read the appropriate VCCI notice. Note that VCCI regulations provide that changes or modifications not expressly approved by Dell Computer Corporation could void your authority to operate this equipment.

Class 1 Notice

This equipment complies with the limits for a Class 1 digital device (devices used in commercial and/or industrial environments) and conforms to the standards for information technology equipment that are set by the Voluntary Control Council for Interference for preventing radio frequency interference in commercial and/or industrial areas.

Consequently, when used in a residential area or in an area adjacent to a residential area, this equipment may cause radio interference with radio and television receivers or other communications equipment.

To ensure that such radio interference does not occur, it is important to install and use this equipment in accordance with the manufacturer’s instruction manual.

Class 2 Notice

This equipment complies with the limits for a Class 2 digital device (devices used in or adjacent to a residential environment) and conforms to the standards for information technology equipment that are set by the Voluntary Control Council for Interference for preventing radio frequency interference in residential areas.

However, this equipment does generate, use, and can radiate radio frequency energy and, if not installed and used in accordance with the manufacturer’s instruction manual, may cause interference with radio and television reception. Therefore, it is important to adhere to the manufacturer’s instructions for installing and using this equipment.

Korean Regulatory Notice

To determine which classification (Class A or B) applies to your computer system (or other Dell digital apparatus), examine all registration labels located on the bottom or back panel of your computer (or other Dell digital apparatus), on card-mounting brackets, and on the cards themselves. If any one of the labels carries a Class A rating, your entire system is considered to be a Class A digital device. If *all* labels carry either the Class B rating or the FCC logo (FCC), your system is considered to be a Class B digital device.

NOTE: Class A devices are for business purposes. Class B devices are for nonbusiness purposes.

Class A Device

Please note that this device has been approved for business purposes with regard to electromagnetic interference. If you find that this device is not suitable for your use, you may exchange it for a device that has been approved for use in residential as well as business environments.

Class B Device

Please note that this device has been approved for non-business purposes and may be used in any environment, including residential areas.

Polish Center for Testing and Certification Notice

The equipment should draw power from a socket with an attached protection circuit (a three-prong socket). All equipment that works together (computer, monitor, printer, and so on) should have the same power supply source.

The phasing conductor of the room's electrical installation should have a reserve short-circuit protection device in the form of a fuse with a nominal value no larger than 10 amperes (A).

To completely switch off the equipment, the power supply cable must be removed from the power supply socket, which should be located near the equipment and easily accessible.

A protection mark "B" confirms that the equipment is in compliance with the protection usage requirements of standards PN-93/T-42107 and PN-89/E-06251.

Wymagania Polskiego Centrum Badań i Certyfikacji

Urządzenie powinno być zasilane z gniazda z przyłączonym obwodem ochronnym (gniazdo z kołkiem). Współpracujące ze sobą urządzenia (komputer, monitor, drukarka) powinny być zasilane z tego samego źródła.

Instalacja elektryczna pomieszczenia powinna zawierać w przewodzie fazowym rezerwową ochronę przed zwarzaniem, w postaci bezpiecznika o wartości znamionowej nie większej niż 10A (amperów).

W celu całkowitego wyłączenia urządzenia z sieci zasilania, należy wyjąć wtyczkę kabla zasilającego z gniazdka, które powinno znajdować się w pobliżu urządzenia i być łatwo dostępne.

Znak bezpieczeństwa "B" potwierdza zgodność urządzenia z wymaganiami bezpieczeństwa użytkowania zawartymi w PN-93/T-42107 i PN-89/E-06251.

Pozostałe instrukcje bezpieczeństwa

- Nie należy używać wtyczek adapterowych lub usuwać kołka obwodu ochronnego z wtyczki. Jeżeli konieczne jest użycie przedłużacza to należy użyć przedłużacza 3-żyłowego z prawidłowo połączonym przewodem ochronnym.
- System komputerowy należy zabezpieczyć przed nagłymi, chwilowymi wzrostami lub spadkami napięcia, używając eliminatora przepięć, urządzenia dopasowującego lub bezzakłóceniewego źródła zasilania.
- Należy upewnić się, aby nic nie leżało na kablach systemu komputerowego, oraz aby kable nie były umieszczone w miejscu, gdzie można byłoby na nie nadeptywać lub potykać się o nie.
- Nie należy rozlewać napojów ani innych płynów na system komputerowy.

- Nie należy wpychać żadnych przedmiotów do otworów systemu komputerowego, gdyż może to spowodować pożar lub porażenie prądem, poprzez zwarcie elementów wewnętrznych.
- System komputerowy powinien znajdować się z dala od grzejników i źródeł ciepła. Ponadto, nie należy blokować otworów wentylacyjnych. Należy unikać kładzenia luźnych papierów pod komputer oraz umieszczania komputera w ciasnym miejscu bez możliwości cyrkulacji powietrza wokół niego.

NOM 024 Information (Mexico Only)

The following information is provided on the device(s) described in this document in compliance with the requirements of the official Mexican standards (NOM 024):

Exporter:	Dell Computer Corporation One Dell Way Round Rock, TX 78682
Importer:	Dell Computer de México, S.A. de C.V. Rio Lerma No. 302 - 4° Piso Col. Cuauhtemoc 16500 México, D.F.
Ship to:	Dell Computer de México, S.A. de C.V. al Cuidado de Kuehne & Nagel de México S. de R.I. Avenida Soles No. 55 Col. Peñon de los Baños 15520 México, D.F.
Supply voltage:	115/230 V.C.A. ±10%
Frequency:	60/50 Hz
Current consumption:	6.0/3.0 A

Información para Nom 024 (únicamente para México)

La información siguiente se proporciona en el dispositivo o en los dispositivos descritos en este documento, en cumplimiento con los requisitos de la norma oficial mexicana (Nom 024):

Exportador:	Dell Computer Corporation One Dell Way Round Rock, TX 78682
Importador:	Dell Computer de México, S.A. de C.V. Rio Lerma No. 302 - 4° Piso Col. Cuauhtemoc 16500 México, D.F.
Embarcar a:	Dell Computer de México, S.A. de C.V. al Cuidado de Kuehne & Nagel de México S. de R.I. Avenida Soles No. 55 Col. Peñon de los Baños 15520 México, D.F.
Tensión alimentación:	115/230 V.C.A. ±10%
Frecuencia:	60/50 Hz
Consumo de corriente:	6.0/3.0 A

Appendix E

Warranties and Return Policy

Limited Three-Year Warranty (U.S. Only)

Dell Computer Corporation (“Dell”) manufactures its hardware products from parts and components that are new or equivalent to new in accordance with industry-standard practices. Dell warrants that the hardware products it manufactures will be free from defects in materials and workmanship. The warranty term is three years beginning on the date of invoice, as described in the following text.

Damage due to shipping the products to you is covered under this warranty. Otherwise, this warranty does not cover damage due to external causes, including accident, abuse, misuse, problems with electrical power, servicing not authorized by Dell, usage not in accordance with product instructions, failure to perform required preventive maintenance, and problems caused by use of parts and components not supplied by Dell.

This warranty does not cover any items that are in one or more of the following categories: software; external devices (except as specifically noted); accessories or parts added to a Dell system after the system is shipped from Dell; accessories or parts added to a Dell system through Dell’s system integration department; accessories or parts that are not installed in the Dell factory; or DellWare® products. Monitors, keyboards, and mice that are Dell-branded or that are included on Dell’s standard price list are covered under this warranty; all other monitors, keyboards, and mice (including those sold through the DellWare program) are not covered. Batteries for portable computers are covered only during the initial one-year period of this warranty.

Coverage During Year One

During the one-year period beginning on the invoice date, Dell will repair or replace products covered under this limited warranty that are returned to Dell’s facility. To request warranty service, you must call Dell’s Customer Technical Support within the warranty period. Refer to the chapter titled “Getting Help” in your *Diagnostics and Troubleshooting Guide* to find the appropriate telephone number for obtaining customer assistance. If warranty service is required, Dell will issue a Return Material Authorization Number. You must ship the products back to Dell in their original or equivalent packaging, prepay shipping charges, and insure the shipment or accept the risk of loss or damage during shipment. Dell will ship the repaired or replacement products to you freight prepaid if you use an address in the continental U.S. Shipments to other locations will be made freight collect.

NOTE: Before you ship the product(s) to Dell, back up the data on the hard-disk drive(s) and any other storage device(s) in the product(s). Remove any removable media, such as diskettes, CDs, or PC Cards. Dell does not accept liability for lost data or software.

Dell owns all parts removed from repaired products. Dell uses new and reconditioned parts made by various manufacturers in performing warranty repairs and building replacement products. If Dell repairs or replaces a product, its warranty term is not extended.

Coverage During Years Two and Three

During the second and third years of this limited warranty, Dell will provide, on an exchange basis, replacement parts for the Dell hardware product(s) covered under this limited warranty when a part requires replacement. You must report each instance of hardware failure to Dell's Customer Technical Support in advance to obtain Dell's concurrence that a part should be replaced and to have Dell ship the replacement part. Dell will ship parts using next-business-day delivery, shipping prepaid if you use an address in the continental U.S. Shipments to other locations will be made freight collect. Dell will include a prepaid shipping container with each replacement part for your use in returning the replaced part to Dell. Replacement parts are new or reconditioned. Dell may provide replacement parts made by various manufacturers when supplying parts to you. The warranty term for a replacement part is the remainder of the limited warranty term.

You will pay Dell for replacement parts if the replaced part is not returned to Dell within 30 days after the date the replacement part was shipped by Dell and for parts used to repair systems not covered by this limited warranty. In these events, replacement parts will be priced at Dell's then-current standard prices. Payment for these parts is due within 30 days from the date of invoice.

NOTE: You accept full responsibility for your software and data. Dell is not required to advise or remind you of appropriate backup and other procedures.

General

DELL MAKES NO EXPRESS WARRANTIES BEYOND THOSE STATED IN THIS WARRANTY STATEMENT. DELL DISCLAIMS ALL OTHER WARRANTIES, EXPRESS OR IMPLIED, INCLUDING WITHOUT LIMITATION IMPLIED WARRANTIES OF MERCHANTABILITY AND FITNESS FOR A PARTICULAR PURPOSE. SOME STATES DO NOT ALLOW LIMITATIONS ON IMPLIED WARRANTIES, SO THIS LIMITATION MAY NOT APPLY TO YOU.

DELL'S RESPONSIBILITY FOR MALFUNCTIONS AND DEFECTS IN HARDWARE IS LIMITED TO REPAIR AND REPLACEMENT AS SET FORTH IN THIS WARRANTY STATEMENT. THESE WARRANTIES GIVE YOU SPECIFIC LEGAL RIGHTS, AND

YOU MAY ALSO HAVE OTHER RIGHTS, WHICH VARY FROM STATE TO STATE.

DELL DOES NOT ACCEPT LIABILITY BEYOND THE REMEDIES SET FORTH IN THIS WARRANTY STATEMENT OR LIABILITY FOR INCIDENTAL OR CONSEQUENTIAL DAMAGES, INCLUDING WITHOUT LIMITATION ANY LIABILITY FOR PRODUCTS NOT BEING AVAILABLE FOR USE OR FOR LOST DATA OR SOFTWARE.

SOME STATES DO NOT ALLOW THE EXCLUSION OR LIMITATION OF INCIDENTAL OR CONSEQUENTIAL DAMAGES, SO THE PRECEDING EXCLUSION OR LIMITATION MAY NOT APPLY TO YOU.

These provisions apply to Dell's U.S. limited three-year warranty only. For provisions of any service contract covering your system, refer to the separate service contract that you will receive.

NOTE: If you chose one of the available warranty and service options in place of the standard limited three-year warranty described in the preceding text, the option you chose will be listed on your invoice.

Limited Three-Year Warranty (Canada Only)

Dell Computer Corporation ("Dell") manufactures its hardware products from parts and components that are new or equivalent to new in accordance with industry-standard practices. Dell warrants that the hardware products it manufactures will be free from defects in materials and workmanship. The warranty term is three years beginning on the date of invoice, as described in the following text. This warranty is transferable with the warranted products.

Damage due to shipping the products to you is covered under this warranty. Otherwise, this warranty does not cover damage due to external causes, including accident, abuse, misuse, problems with electrical power, servicing not authorized by Dell, usage not in accordance with product instructions, failure to perform required preventive maintenance, and problems caused by use of parts and components not supplied by Dell.

This warranty does not cover any items that are in one or more of the following categories: software; external devices (except as specifically noted); accessories or parts added to a Dell system after the system is shipped from Dell; accessories or parts added to a Dell system through Dell's system integration department; accessories or parts that are not installed in the Dell factory; or DellWare products. Monitors, keyboards, and mice that are Dell-branded or that are included on Dell's standard price list are covered under this warranty; all other monitors, keyboards, and mice (including those sold through the DellWare program) are not covered. Batteries for portable computers are covered only during the initial one-year period of this warranty.

Coverage During Year One

During the one-year period beginning on the invoice date, Dell will repair or replace products covered under this limited warranty that are returned to Dell's facility. To request warranty service, you must call Dell's Customer Technical Support within the warranty period. Refer to the chapter titled "Getting Help" in your *Diagnostics and Troubleshooting Guide* to find the appropriate telephone number for obtaining customer assistance. If warranty service is required, Dell will issue a Return Material Authorization Number. You must ship the products back to Dell in their original or equivalent packaging, prepay shipping charges, and insure the shipment or accept the risk of loss or damage during shipment. Dell will ship the repaired or replacement products to you freight prepaid if you use an address in Canada. Shipments to other locations will be made freight collect.

NOTE: Before you ship the product(s) to Dell, back up the data on the hard-disk drive(s) and any other storage device(s) in the product(s). Remove any removable media, such as diskettes, CDs, or PC Cards. Dell does not accept liability for lost data or software.

Dell owns all parts removed from repaired products. Dell uses new and reconditioned parts made by various manufacturers in performing warranty repairs and building replacement products. If Dell repairs or replaces a product, its warranty term is not extended, except as may be required by law.

Coverage During Years Two and Three

During the second and third years of this limited warranty, Dell will provide, on an exchange basis, replacement parts for the Dell hardware product(s) covered under this limited warranty when a part requires replacement. You must report each instance of hardware failure to Dell's Customer Technical Support in advance to obtain Dell's concurrence that a part should be replaced and to have Dell ship the replacement part. Dell will ship parts using next-business-day delivery, shipping prepaid if you use an address in Canada. Shipments to other locations will be made freight collect. Dell will include a prepaid shipping container with each replacement part for your use in returning the replaced part to Dell. Replacement parts are new or reconditioned. Dell may provide replacement parts made by various manufacturers when supplying parts to you. The warranty term for a replacement part is the remainder of the limited warranty term.

You will pay Dell for replacement parts if the replaced part is not returned to Dell within 30 days after the date the replacement part was shipped by Dell and for parts used to repair systems not covered by this limited warranty. In these events, replacement parts will be priced at Dell's then-current standard prices. Payment for these parts is due within 30 days from the date of invoice.

NOTE: You accept full responsibility for your software and data. Dell is not required to advise or remind you of appropriate backup and other procedures.

General

DELL MAKES NO EXPRESS WARRANTIES BEYOND THOSE STATED IN THIS WARRANTY STATEMENT. DELL DISCLAIMS ALL OTHER WARRANTIES, EXPRESS OR IMPLIED, INCLUDING WITHOUT LIMITATION IMPLIED WARRANTIES OF MERCHANTABILITY AND FITNESS FOR A PARTICULAR PURPOSE. SOME JURISDICTIONS DO NOT ALLOW LIMITATIONS ON IMPLIED WARRANTIES, SO THIS LIMITATION MAY NOT APPLY TO YOU.

DELL'S RESPONSIBILITY FOR MALFUNCTIONS AND DEFECTS IN HARDWARE IS LIMITED TO REPAIR AND REPLACEMENT AS SET FORTH IN THIS WARRANTY STATEMENT. THESE WARRANTIES GIVE YOU SPECIFIC LEGAL RIGHTS, AND

YOU MAY ALSO HAVE OTHER RIGHTS, WHICH VARY FROM ONE JURISDICTION TO ANOTHER.

DELL DOES NOT ACCEPT LIABILITY BEYOND THE REMEDIES SET FORTH IN THIS WARRANTY STATEMENT OR LIABILITY FOR INCIDENTAL OR CONSEQUENTIAL DAMAGES, INCLUDING WITHOUT LIMITATION ANY LIABILITY FOR PRODUCTS NOT BEING AVAILABLE FOR USE OR FOR LOST DATA OR SOFTWARE.

SOME JURISDICTIONS DO NOT ALLOW THE EXCLUSION OR LIMITATION OF INCIDENTAL OR CONSEQUENTIAL DAMAGES, SO THE PRECEDING EXCLUSION OR LIMITATION MAY NOT APPLY TO YOU.

These provisions apply to Dell's Canadian limited three-year warranty only. For provisions of any service contract covering your system, refer to the separate service contract that you will receive.

NOTE: If you chose one of the available warranty and service options in place of the standard limited three-year warranty described in the preceding text, the option you chose will be listed on your invoice.

“Total Satisfaction” Return Policy (U.S. and Canada Only)

If you are an end-user customer who bought products directly from a Dell company, you may return them to Dell up to 30 days from the date of invoice for a refund of the product purchase price if already paid. This refund will not include any shipping and handling charges shown on your invoice. If your organization bought the products from Dell under a written agreement with Dell, there may be different terms for the return of products under this policy, based on your agreement with Dell. To return products, you must call Dell Customer Service at the telephone number shown in the chapter titled “Getting Help” in your *Diagnostics and Troubleshooting Guide* to receive a Credit Return Authorization Number. You must ship the products to Dell in their original packaging, prepay shipping charges, and insure the shipment or accept the risk of loss or damage during shipment. You may return software for refund or credit only if the sealed package containing the diskette(s) or CD(s) is unopened. Returned products must be in as-new condition, and all of the manuals, diskette(s), CD(s), power cables, and other items included with a product must be returned with it.

This “Total Satisfaction” Return Policy does not apply to DellWare products, which may be returned under DellWare's current return policy.

Appendix F

Beep Codes and System Messages

The information in this appendix replaces the information about beep codes and system messages described in your *Diagnostics and Troubleshooting Guide*. Use the information in this appendix for descriptions of any beep codes emitted by your system or system messages displayed on the screen by the system basic input/output system (BIOS). If the corrective action for a beep code or error message requires troubleshooting a problem, refer to Chapter 5 in your *Diagnostics and Troubleshooting Guide* for information on running the appropriate system diagnostics test(s).

NOTE: The system diagnostics is run directly from the Dell Server Assistant CD. See Chapter 2, "Using the Dell Server Assistant CD," for information on running the CD.

System Error Messages

Table F-1 lists system error messages that can be generated by the system BIOS.

Table F-1. System Error Messages

Message	Probable Cause	Corrective Action
System battery is dead - Replace and run Setup	The battery on the system board is dead.	Replace the battery on the system board and run the System Setup program to restore your system configuration.
System CMOS checksum bad - Run Setup	The CMOS configuration data is corrupted.	Run the System Setup program to restore your system configuration.
Incorrect drive A type - Run Setup	The installed diskette drive does not match the diskette drive type in CMOS.	Run the System Setup program to correct the diskette drive type. See "Diskette Drive A and Diskette Drive B" in Chapter 4.
Incorrect drive B type - Run Setup	The installed diskette drive does not match the diskette drive type in CMOS.	Run the System Setup program to correct the diskette drive type. See "Diskette Drive A and Diskette Drive B" in Chapter 4.
Keyboard error	A cable or connector may be loose, or the keyboard may be faulty.	Check the keyboard cable and connector for proper connection. If the problem persists, run the Keyboard Test Group in the system diagnostics to determine whether the keyboard or the keyboard controller is faulty. See the chapter titled "Running the Diskette-Based Diagnostics" in your <i>Diagnostics and Troubleshooting Guide</i> .

NOTE: For the full name of an abbreviation or acronym used in this table, see the Glossary.

Table F-1. System Error Messages (continued)

Message	Probable Cause	Corrective Action
Stuck key	A cable or connector may be loose, or the keyboard may be faulty.	Check the keyboard cable and connector for proper connection. If the problem persists, run the Keyboard Test Group in the diskette-based diagnostics to determine whether the keyboard or the keyboard controller is faulty. See the chapter titled “Running the Diskette-Based Diagnostics” in your <i>Diagnostics and Troubleshooting Guide</i> .
System/Shadow RAM failed at offset:	One or more DIMMs may be improperly seated or faulty.	Remove and reseat the DIMMs. See “Removing a DIMM” and “Installing a DIMM” in Chapter 7. If the problem persists, run the RAM Test Group in the system diagnostics to isolate the problem.
Operating system not found	The diskette in drive A or your hard-disk drive does not have a bootable operating system on it.	Install a diskette with a bootable operating system in drive A, or load a bootable operating system on your hard-disk drive. See the chapter titled “Running the Diskette-Based Diagnostics” in your <i>Diagnostics and Troubleshooting Guide</i> .
System cache error - Cache disabled	The microprocessor chip on the system board may be malfunctioning.	Run the System Set Test Group to determine whether the microprocessor chip is faulty. See the chapter titled “Running the Diskette-Based Diagnostics” in your <i>Diagnostics and Troubleshooting Guide</i> .
System timer error	A chip on the system board may be malfunctioning.	Run the System Set Test Group to determine whether the microprocessor chip is faulty. See the chapter titled “Running the Diskette-Based Diagnostics” in your <i>Diagnostics and Troubleshooting Guide</i> . See “Installing a Microprocessor Upgrade” in Chapter 7 if the diagnostic indicates that you need to replace the microprocessor chip.
Real-time clock error	The real-time clock on the system board may be malfunctioning.	Run the System Set Test Group to determine whether the real-time clock on the system board is faulty. See the chapter titled “Running the Diskette-Based Diagnostics” in your <i>Diagnostics and Troubleshooting Guide</i> . A chip failure on the system board usually requires that you replace the system board.

NOTE: For the full name of an abbreviation or acronym used in this table, see the Glossary.

Table F-1. System Error Messages (continued)

Message	Probable Cause	Corrective Action
Keyboard controller error	A cable or connector may be loose, or the keyboard or keyboard controller may be faulty.	Check the keyboard cable and connector for proper connection. If the problem persists, run the Keyboard Test Group in the diskette-based diagnostics to determine whether the keyboard or the keyboard controller is faulty. See the chapter titled "Running the Diskette-Based Diagnostics" in your <i>Diagnostics and Troubleshooting Guide</i> .
EISA configuration NVRAM bad	The EISA jumper may have been accidentally installed.	Remove the EISA jumper, reboot the system, and restore the EISA configuration parameters. See "Starting the EISA Configuration Utility" in Chapter 5.
EISA configuration error	The EISA configuration data in NVRAM does not match the installed EISA expansion cards.	Verify that any installed EISA expansion cards are properly seated, and then run the EISA configuration utility to verify that the configuration parameters are correct. See the chapter titled "Using the EISA Configuration Utility."
Invalid CPU speed detected - Check jumpers	The microprocessor speed jumper plug may be absent or installed on the wrong jumper pins.	Check the microprocessor speed jumpers. See Table B-1 in Appendix B.
Memory size limit exceeded	The size of installed DIMM memory is greater than 512 megabytes (MB).	Verify that the total installed DIMM memory does not exceed 512 MB. See "Adding Memory" in Chapter 7.
Processor bus terminator not installed	In a single-microprocessor system, a terminator card is not installed in the secondary microprocessor connector.	Install a terminator card in the secondary microprocessor connector. See "Installing a Microprocessor" in Chapter 7.
Warning: Processor is not installed in Processor 1 slot.	No microprocessor module is installed in the primary microprocessor connector.	Move the microprocessor to the primary microprocessor connector. See "Installing a Microprocessor" in Chapter 7.
Processor X temperature sensor is not installed.	The primary (X=1) or secondary (X=2) microprocessor's temperature sensor is not connected to the system board.	Connect the microprocessor's temperature sensor to the appropriate connector on the system board. See "Installing a Microprocessor" in Chapter 7.

NOTE: For the full name of an abbreviation or acronym used in this table, see the Glossary.

Table F-1. System Error Messages (continued)

Message	Probable Cause	Corrective Action
Warning: System fan is not functioning.	The cooling-fan power cable is disconnected, or the cooling fan is faulty.	Ensure that the fan is connected to the FAN connector on the system board. If the problem persists, the fan must be replaced.
Resource conflict	The BIOS detected a resource conflict while configuring a plug and play ISA or PCI expansion card.	See “Resolving Resource Conflicts” in Chapter 5.
Warning: IRQ not initialized	The BIOS detected a resource conflict while configuring a plug and play ISA or PCI expansion card.	See “Resolving Resource Conflicts” in Chapter 5.
Expansion ROM not initialized	The BIOS detected a resource conflict while configuring a plug and play ISA or PCI expansion card.	See “Resolving Resource Conflicts” in Chapter 5.
System configuration data write error	A chip on the system board may be malfunctioning.	Run the System Set tests in system diagnostics. See the chapter titled “Running the Diskette-Based Diagnostics” in your <i>Diagnostics and Troubleshooting Guide</i> . A faulty chip on the system board usually requires that you replace the system board.
System memory size has changed - Run Configuration Utility	DIMM memory may have been added or removed, or one or more DIMMs may be improperly seated or faulty.	Run the EISA Configuration Utility (see the chapter titled “Using the EISA Configuration Utility”). Remove and reseat the DIMMs. (See “Removing a DIMM” and “Installing a DIMM” in Chapter 7.) If the problem persists, run the RAM Test Group in the system diagnostics. See the chapter titled “Running the Diskette-Based Diagnostics” in your <i>Diagnostics and Troubleshooting Guide</i> for instructions.

NOTE: For the full name of an abbreviation or acronym used in this table, see the Glossary.

System Beep Codes

codes are generated to communicate a problem to the computer user when there is no other way to communicate the problem.

Table F-2 lists beep codes that can be generated by the system BIOS to indicate problems in the system. Beep

Table F-2. System Beep Codes

Code	Probable Cause	Corrective Action
1-2	Invalid Expansion ROM checksum	An expansion card could be improperly seated or faulty. Ensure that all expansion cards are properly seated; then reboot the system. Refer to the documentation that came with the expansion card for troubleshooting information.
1-2-2-3	Invalid BIOS ROM checksum	Fatal error. This error usually requires that you have a service technician reinstall the BIOS firmware.
1-3-1-1	DRAM refresh failure	Remove and reseal the DIMMS. (See “Removing a DIMM” and “Installing a DIMM” in Chapter 7.) Reboot the system, and if the problem persists, have the system board replaced.
1-3-1-3	Keyboard controller error	Check the keyboard cable and connector for proper connection. If the problem persists, run the Keyboard Test Group in the system diagnostics to determine whether the keyboard or the keyboard controller is faulty. See the chapter titled “Running the Diskette-Based Diagnostics” in your <i>Diagnostics and Troubleshooting Guide</i> .
1-3-3-1	No DIMM memory installed	Check the DIMMs to ensure that they are properly seated. (See “Removing a DIMM” and “Installing a DIMM” in Chapter 7.) If the problem persists, run the RAM Test Group in the system diagnostics. See the chapter titled “Running the Diskette-Based Diagnostics” in your <i>Diagnostics and Troubleshooting Guide</i> .
1-3-4-1	DRAM failure	Check the DIMMs to ensure that they are properly seated. (See “Removing a DIMM” and “Installing a DIMM” in Chapter 7.) If the problem persists, run the RAM Test Group in the system diagnostics. See the chapter titled “Running the Diskette-Based Diagnostics” in your <i>Diagnostics and Troubleshooting Guide</i> .
1-3-4-3	DRAM failure	Check the DIMMs to ensure that they are properly seated. (See “Removing a DIMM” and “Installing a DIMM” in Chapter 7.) If the problem persists, run the RAM Test Group in the system diagnostics. See the chapter titled “Running the Diskette-Based Diagnostics” in your <i>Diagnostics and Troubleshooting Guide</i> .
1-4-1-1	DRAM failure	Fatal error. Replace the system board.

NOTE: For the full name of an abbreviation or acronym used in this table, see the Glossary.

Table F-2. System Beep Codes (continued)

Code	Probable Cause	Corrective Action
1-4-2-1	CMOS failure	Run the System Set Test Group in the system diagnostics to isolate the problem. See the chapter titled “Running the Diskette-Based Diagnostics” in your <i>Diagnostics and Troubleshooting Guide</i> .
1-4-3-1	Memory controller or DIMM failure	Check the DIMMs to ensure that they are properly seated. (See “Removing a DIMM” and “Installing a DIMM” in Chapter 7.) If the problem persists, run the RAM Test Group in the system diagnostics. See the chapter titled “Running the Diskette-Based Diagnostics” in your <i>Diagnostics and Troubleshooting Guide</i> .
2-2-3-1	Unexpected interrupt	Ensure that all expansion cards are properly seated (see “Removing an Expansion Card” and “Installing an Expansion Card” in Chapter 7); then reboot the system.
3-2-2-1	Gate A20 failure	Fatal error. Have the system board replaced.
4-2-4-3	Keyboard controller error	Fatal error. Have the system board replaced.
4-2-4-4	Gate A20 failure	Fatal error. Have the system board replaced.

NOTE: For the full name of an abbreviation or acronym used in this table, see the Glossary.

Starting the System Diagnostics

The system diagnostics is run directly from the *Dell Server Assistant* CD. See Chapter 2, “Using the Dell Server Assistant CD,” for information on running the CD.

Follow these steps to run the diagnostics from the *Dell Server Assistant* CD:

- 1. Turn on the computer.**
- 2. Boot the system from the *Dell Server Assistant* CD.**

If the system fails to boot, see the chapter titled “Getting Help” in the *Diagnostics and Troubleshooting Guide* for instructions on obtaining technical assistance.

- 3. From the Main Menu, select the Run System Diagnostics option from the Run System Utilities category.**

Glossary

The following list defines or identifies technical terms, abbreviations, and acronyms used in Dell user documents.

NOTE: Unless otherwise specified, these definitions may not apply to operating systems other than MS-DOS® or Microsoft Windows®.

A

Abbreviation for ampere(s).

AC

Abbreviation for alternating current.

adapter card

An expansion card that plugs into an expansion-card connector on the computer's system board. An adapter card adds some specialized function to the computer by providing an interface between the expansion bus and a peripheral device. Examples of adapter cards include network cards, sound boards, and SCSI adapters.

ADC

Abbreviation for analog-to-digital converter.

ADI

Abbreviation for Autodesk Device Interface.

AI

Abbreviation for artificial intelligence.

ANSI

Acronym for American National Standards Institute.

application program

Software designed to help you perform a specific task, such as a spreadsheet or word processor. Application programs are distinct from operating system and utility software.

ASCII

Acronym for American Standard Code for Information Interchange. A text file containing only characters from the ASCII character set (usually created with a text editor, such as MS-DOS Editor or Notepad in Windows), is called an ASCII file.

ASIC

Acronym for application-specific integrated circuit.

ASPI

Advanced SCSI programming interface.

autoexec.bat file

When you boot your computer, MS-DOS runs any commands contained in the text file, **autoexec.bat** (after running any commands in the **config.sys** file). An **autoexec.bat** file is not required to boot MS-DOS, but provides a convenient place to run commands that are essential for setting up a consistent computing environment—such as loading mouse or network software.

backup

A copy of a program or data file. As a precaution, you should back up your computer's hard-disk drive on a regular basis. Before making a change to the configuration of your computer, you should back up important start-up files, such as **autoexec.bat** and **config.sys** for MS-DOS or **win.ini** and **system.ini** for Windows.

base memory

Synonym for conventional memory. See also **conventional memory**.

BASIC

Acronym for Beginner's All-Purpose Symbolic Instruction Code, a programming language. MS-DOS includes a version of BASIC.

batch file

An ASCII text file containing a list of commands that run in sequence. Batch files must have a filename extension of **bat**.

baud rate

Data transmission speed. For example, modems are designed to transmit data at one or more specified baud rate(s) through the COM (serial) port of a computer.

BBS

Abbreviation for bulletin board service. A computer system that serves as a central location for accessing data or relaying messages by modem. For example, Dell's Tech-Connect BBS contains the latest version of software such as video drivers and the *Dell Directory*. If your system has a modem, you can access the BBS and download the most recent version of this software.

beep code

A diagnostic system message in the form of a series of beeps from your computer's speaker. Refer to your *Diagnostics and Troubleshooting Guide* for a complete discussion of system beep codes.

BIOS

Acronym for basic input/output system. Your computer's BIOS contains programs stored on a ROM chip. The BIOS controls the following:

- Communications between the microprocessor and peripheral devices, such as the keyboard and the video adapter
- Miscellaneous functions, such as system messages

bit

The smallest unit of information interpreted by your computer.

boot routine

When you start your computer, it clears all memory, initializes devices, and loads the operating system. Unless the operating system fails to respond, you can reboot (also called warm boot) your computer by pressing <Ctrl><Alt>; otherwise, you must perform a cold boot by pressing the reset button (if your computer has one) or by turning the computer off, then back on.

bootable diskette

You can start your computer from a diskette in drive A. To make a bootable diskette, insert a diskette in drive A, type `sys a:` at the command line prompt, then press <Enter>. Use this bootable diskette if your computer will not boot from the hard-disk drive.

bpi

Abbreviation for bits per inch.

bps

Abbreviation for bits per second.

BTU

Abbreviation for British thermal unit.

bus

A bus forms an information pathway between the components of a computer. Your computer contains an expansion bus that allows the microprocessor to communicate with controllers for all the various peripheral devices connected to the computer. Your computer also contains an address bus and a data bus for communications between the microprocessor and RAM.

byte

Eight contiguous bits of information, the basic data unit used by your computer.

BZT

Abbreviation for *Bundesamt für Zulassungen in der Telekommunikation*.

C

Abbreviation for Celsius.

cache

To facilitate quicker data retrieval, a storage area for keeping a copy of data or instructions. For example, your computer's BIOS may cache ROM code in faster RAM. Or, a disk-cache utility may reserve RAM in which to store frequently accessed information from your computer's disk drives; when a program makes a request to a disk drive for data that is in the cache, the disk-cache utility can retrieve the data from RAM faster than from the disk drive.

card-edge connector

On the bottom of an expansion card, the metal-contact section that plugs into an expansion-card connector.

CCFT

Abbreviation for cold cathode fluorescent tube.

CD-ROM

Abbreviation for compact disc read-only memory. CD-ROM drives use optical technology to read data from compact discs. Compact discs are read-only storage devices; you cannot write new data to a compact disc with standard CD-ROM drives.

CGA

Abbreviation for color graphics adapter.

cm

Abbreviation for centimeter(s).

CMOS

Acronym for complementary metal-oxide semiconductor. In computers, CMOS memory chips are often used for NVRAM storage.

COMn

The MS-DOS device names for the first through fourth serial ports on your computer are COM1, COM2, COM3, and COM4. MS-DOS supports up to four serial ports. However, the default interrupt for COM1 and COM3 is IRQ4, and the default interrupt for COM2 and COM4 is IRQ3. Therefore, you must be careful when configuring software that runs a serial device so that you don't create an interrupt conflict.

CON

The MS-DOS device name for the console, which includes your computer's keyboard and text displayed on the screen.

config.sys file

When you boot your computer, MS-DOS runs any commands contained in the text file, **config.sys** (before running any commands in the **autoexec.bat** file). A **config.sys** file is not required to boot MS-DOS, but provides a convenient place to run commands that are essential for setting up a consistent computing environment—such as loading device drivers with a **device=** statement.

controller

A chip or expansion card that controls the transfer of data between the microprocessor and a peripheral, such as a disk drive or the keyboard.

conventional memory

The first 640 KB of RAM. Unless they are specially designed, MS-DOS programs are limited to running in conventional memory. See also **EMM**, **expanded memory**, **extended memory**, **HMA**, **memory manager**, **upper memory area**, and **XMM**.

coprocessor

A coprocessor relieves the computer's microprocessor of specific processing tasks. A math coprocessor, for example, handles numeric processing. A graphics coprocessor handles video rendering. Intel486 DX™, IntelDX2™, IntelDX4™, and Pentium® microprocessors include a built-in math coprocessor.

cpi

Abbreviation for characters per inch.

CPU

Abbreviation for central processing unit. See also **microprocessor**.

cursor

In character-based MS-DOS programs, the cursor is usually a block or an underscore (possibly blinking) that represents the position at which the next character typed will appear. Windows programs can design their own cursors—common cursor symbols include the pointer arrow and the text-insertion I-beam.

DAC

Acronym for digital-to-analog converter.

DAT

Acronym for digital audio tape.

dB

Abbreviation for decibel(s).

dBA

Abbreviation for adjusted decibel(s).

DC

Abbreviation for direct current.

device driver

A device driver allows the operating system or a program to interface correctly with a peripheral, such as a printer or network card. Some device drivers—such as network drivers—must be loaded from the **config.sys** file (with a

device= statement) or as memory-resident programs (usually, from the **autoexec.bat** file). Others—such as video drivers—must load when you start the program for which they were designed.

diagnostics

See **diskette-based diagnostics** and **embedded diagnostics**.

DIMM

Acronym for dual in-line memory module.

DIN

Acronym for *Deutsche Industrie Norm*.

DIP

Acronym for dual in-line package. A circuit board, such as a system board or expansion card, may contain DIP switches for configuring the circuit board. DIP switches are always toggle switches, with an ON position and an OFF position.

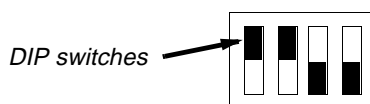

directory

Directories help keep related files organized on a disk in a hierarchical, “inverted tree” structure. Each disk has a “root” directory; for example, a `c:\>` prompt normally indicates that you are at the root directory of hard-disk drive C. Additional directories that branch off of the root directory are called *subdirectories*. Subdirectories may contain additional directories branching off of them.

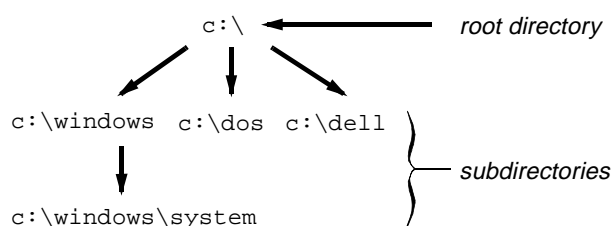

diskette-based diagnostics

A comprehensive set of diagnostic tests for your Dell computer. To use the diskette-based diagnostics, you must boot your computer from the *Dell Diagnostics Diskette*. Refer to your *Diagnostics and Troubleshooting Guide* for a complete discussion about how to use the diskette-based diagnostics.

display adapter

See **video adapter**.

DMA

Abbreviation for direct memory access. A DMA channel allows certain types of data transfer between RAM and a device to bypass the microprocessor.

DOC

Abbreviation for Department of Communications (in Canada).

dpi

Abbreviation for dots per inch.

DPMS

Abbreviation for Display Power Management Signaling. A standard developed by the Video Electronics Standards Association that defines the hardware signals sent by a video controller to activate power management states in a video display or monitor. A monitor is said to be DPMS-compliant when it is designed to enter a power management state after receiving the appropriate signal from a computer’s video controller.

DRAM

Abbreviation for dynamic random-access memory. A computer’s RAM is usually made up entirely of DRAM chips. Because DRAM chips cannot store an electrical charge indefinitely, your computer continually refreshes each DRAM chip in the computer.

drive-type number

Your computer can recognize a number of specific hard-disk drives. Each is assigned a drive-type number that is stored in NVRAM. The hard-disk drive(s) specified in your computer’s System Setup program must match the actual drive(s) installed in the computer. The System Setup program also allows you to specify physical parameters (cylinders, heads, write precomp, landing zone, and capacity) for drives not included in the table of drive types stored in NVRAM.

DS/DD

Abbreviation for double-sided/double-density.

DS/HD

Abbreviation for double-sided/high-density.

DTE

Abbreviation for data terminal equipment. Any device (such as a computer system) that can send data in digital form by means of a cable or communications line. The DTE is connected to the cable or communications line through a data communications equipment (DCE) device, such as a modem.

ECC

Abbreviation for error correction code.

ECP

Abbreviation for Extended Capabilities Port.

EDO

Abbreviation for extended-data output. A type of RAM chip that holds data on the chip's output data lines for a longer period of time than fast-page mode RAM chips. The EDO RAM chips are also faster than fast-page mode RAM chips.

EEPROM

Acronym for electrically erasable programmable read-only memory.

EGA

Abbreviation for enhanced graphics adapter.

EISA

Acronym for Extended Industry-Standard Architecture, a 32-bit expansion-bus design. The expansion-card connectors in an EISA computer are also compatible with 8- or 16-bit ISA expansion cards.

To avoid a configuration conflict when installing an EISA expansion card, you must use the EISA Configuration Utility. This utility allows you to specify which expansion slot contains the card and obtains information about the card's required system resources from a corresponding EISA configuration file.

embedded diagnostics

Diagnostic tests stored in flash memory on some Dell computers to assist in troubleshooting component failure that can prevent your computer from booting. Refer to your *Diagnostics and Troubleshooting Guide* for a complete discussion about how to use the embedded diagnostics.

EMC

Abbreviation for Electromagnetic Compatibility.

EMI

Abbreviation for electromagnetic interference.

EMM

Abbreviation for expanded memory manager. A software utility that uses extended memory to emulate expanded memory on computers with an Intel386™ or higher micro-processor. See also **conventional memory**, **expanded memory**, **extended memory**, **memory manager**, and **XMM**.

EMS

Abbreviation for Expanded Memory Specification. See also **expanded memory**, **memory manager**, and **XMS**.

EPROM

Acronym for erasable programmable read-only memory.

ESD

Abbreviation for electrostatic discharge. Refer to "Safety Instructions" at the front of your *User's Guide* for a complete discussion of ESD.

ESDI

Acronym for enhanced small-device interface.

expanded memory

A technique for accessing RAM above 1 MB. To enable expanded memory on your computer, you must use an EMM. You should configure your system to support expanded memory only if you run application programs that can use (or require) expanded memory. See also **conventional memory**, **EMM**, **extended memory**, and **memory manager**.

expansion bus

Your computer contains an expansion bus that allows the microprocessor to communicate with controllers for peripheral devices, such as a network card or an internal modem.

expansion-card connector

A connector on the computer's system board for plugging in an expansion card.

extended memory

RAM above 1 MB. Most software that can use it, such as Windows, requires that extended memory be under the control of an XMM. See also **conventional memory**, **expanded memory**, **memory manager**, and **XMM**.

external cache memory

A RAM cache using SRAM chips. Because SRAM chips operate at several times the speed of DRAM chips, the microprocessor can retrieve data and instructions faster from external cache memory than from RAM.

F

Abbreviation for Fahrenheit.

FAT

Acronym for file allocation table. The file system structure used by MS-DOS to organize and keep track of file storage. The Microsoft Windows NT[®] and IBM[®] OS/2[®] operating systems can optionally use a FAT file system structure.

FCC

Abbreviation for Federal Communications Commission.

flash memory

A type of EEPROM chip that can be reprogrammed from a utility on diskette while still installed in a computer; most EEPROM chips can only be rewritten with special programming equipment.

format

To prepare a hard-disk drive or diskette for storing files. An unconditional format deletes all data stored on the disk. The **format** command in MS-DOS 5.0 or higher includes an option that allows you to unformat a disk, if you have not yet used the disk for file storage.

ft

Abbreviation for feet.

g

Abbreviation for gram(s).

G

Abbreviation for gravities.

GB

Abbreviation for gigabyte(s). A gigabyte equals 1,024 megabytes or 1,073,741,824 bytes.

graphics coprocessor

See **coprocessor**.

graphics mode

See **video mode**.

GUI

Acronym for graphical user interface.

h

Abbreviation for hexadecimal. A base-16 numbering system, often used in programming to identify addresses in the computer's RAM and I/O memory addresses for devices. The sequence of decimal numbers from 0 through 16, for example, is expressed in hexadecimal notation as: 0, 1, 2, 3, 4, 5, 6, 7, 8, 9, A, B, C, D, E, F, 10. In text, hexadecimal numbers are often followed by *h* or preceded by *0x*. MS-DOS conventional memory—the first 640 KB of memory addresses—is from 00000h to 9FFFFh; the MS-DOS upper memory area—memory addresses between 640 KB and 1 MB—is from A0000h to FFFFFh.

heat sink

A metal plate with metal pegs or ribs that help dissipate heat. Some microprocessors include a heat sink.

HMA

Abbreviation for high memory area. The first 64 KB of extended memory above 1 MB. A memory manager that conforms to the XMS can make the HMA a direct extension of conventional memory. See also **conventional memory**, **memory manager**, **upper memory area**, and **XMM**.

host adapter

A host adapter implements communication between the computer's bus and the controller for a peripheral. (Hard-disk drive controller subsystems include integrated host adapter circuitry.) To add a SCSI expansion bus to your system, you must install the appropriate host adapter.

HPFS

Abbreviation for the High Performance File System option in the OS/2 and Windows NT operating systems.

Hz

Abbreviation for hertz.

I/O

Abbreviation for input/output. The keyboard and a printer, for example, are I/O devices. In general, I/O activity can be differentiated from computational activity. For example, when a program sends a document to the printer, it is engaging in I/O activity; when the program sorts a list of terms, it is engaging in computational activity.

ID

Abbreviation for identification.

interlacing

A technique for increasing video resolution by only updating alternate horizontal lines on the screen. Because interlacing can result in noticeable screen flicker, most users prefer noninterlaced video adapter resolutions.

internal microprocessor cache

An instruction and data cache built in to the microprocessor. The Intel486, IntelDX2, and IntelDX4 microprocessors include an 8-KB internal cache. The Pentium microprocessor includes a 16-KB internal cache, which is set up as an 8-KB read-only instruction cache and an 8-KB read/write data cache.

IPX

Acronym for internetwork packet exchange.

IRQ

Abbreviation for interrupt request. A signal that data is about to be sent to or received by a peripheral travels by an IRQ line to the microprocessor. Each peripheral connection must be assigned an IRQ number. For example, the first serial port in your computer (COM1) is assigned to IRQ4 by default. Two devices can share the same IRQ assignment, but you cannot operate both devices simultaneously.

ISA

Acronym for Industry-Standard Architecture. A 16-bit expansion bus design. The expansion-card connectors in an ISA computer are also compatible with 8-bit ISA expansion cards.

ITE

Abbreviation for information technology equipment.

JEIDA

Acronym for Japanese Electronic Industry Development Association.

K

Abbreviation for kilo-, indicating 1,000.

KB

Abbreviation for kilobyte(s), 1,024 bytes.

KB/sec

Abbreviation for kilobyte(s) per second.

Kbit(s)

Abbreviation for kilobit(s), 1,024 bits.

Kbit(s)/sec

Abbreviation for kilobit(s) per second.

key combination

A command requiring that you press multiple keys at the same time. For example, you can reboot your computer by pressing the <Ctrl><Alt> key combination.

kg

Abbreviation for kilogram(s), 1,000 grams.

kHz

Abbreviation for kilohertz, 1,000 hertz.

LAN

Acronym for local area network. A LAN system is usually confined to the same building or a few nearby buildings, with all equipment linked by wiring dedicated specifically to the LAN.

lb

Abbreviation for pound(s).

LCD

Abbreviation for liquid crystal display. A low-power display often used for notebook computers. An LCD consists of a liquid crystal solution between two sheets of polarizing material. An electric current causes each crystal to act like a shutter that can open to allow light past or close to block the light.

LED

Abbreviation for light-emitting diode. An electronic device that lights up when a current is passed through it.

LIF

Acronym for low insertion force. Some computers use LIF sockets and connectors to allow devices such as the microprocessor chip to be installed or removed with minimal stress to the device.

LIM

Acronym for Lotus/Intel/Microsoft. LIM usually refers to version 4.0 of the EMS.

LN

Abbreviation for load number.

local bus

On a computer with local-bus expansion capability, certain peripheral devices (such as the video adapter circuitry) can be designed to run much faster than they would with a traditional expansion bus. Some local-bus designs allow peripherals to run at the same speed and with the same width data path as the computer's microprocessor.

LPTn

The MS-DOS device names for the first through third parallel printer ports on your computer are LPT1, LPT2, and LPT3.

LUN

Acronym for logical unit number.

m

Abbreviation for meter(s).

mA

Abbreviation for milliamper(s).

mAh

Abbreviation for milliamper-hour(s).

math coprocessor

See **coprocessor**.

MB

Abbreviation for megabyte(s). The term *megabyte* means 1,048,576 bytes; however, when referring to hard-disk drive storage, the term is often rounded to mean 1,000,000 bytes.

MBR

Abbreviation for master boot record.

MDA

Abbreviation for monochrome display adapter.

memory

A computer can contain several different forms of memory, such as RAM, ROM, and video memory. Frequently, the word *memory* is used as a synonym for RAM; for example, an unqualified statement such as "...a computer with 8 MB of memory" refers to a computer with 8 MB of RAM.

memory address

A specific location, usually expressed as a hexadecimal number, in the computer's RAM.

memory manager

A utility that controls the implementation of memory in addition to conventional memory, such as extended or expanded memory. See also **conventional memory**, **EMM**, **expanded memory**, **extended memory**, **HMA**, **upper memory area**, and **XMM**.

MGA

Abbreviation for monochrome graphics adapter.

MHz

Abbreviation for megahertz.

microprocessor

Because it is the primary computational chip inside the computer, it is customary to refer to the microprocessor as "the computer's brain." The microprocessor contains an arithmetic processing unit and a control unit. Software written for one microprocessor must usually be revised to run on another microprocessor. *CPU* is a synonym for microprocessor.

min

Abbreviation for minute(s).

mm

Abbreviation for millimeter(s).

mouse

A pointing device that controls the movement of the cursor on a screen. Mouse-aware software allows you to activate commands by clicking a mouse button while pointing at objects displayed on the screen.

ms

Abbreviation for millisecond(s).

MS-DOS

Abbreviation for Microsoft Disk Operating System.

MTBF

Abbreviation for mean time between failures.

multifrequency monitor

A monitor that supports several video standards. A multifrequency monitor can adjust to the frequency range of the signal from a variety of video adapters.

mV

Abbreviation for millivolt(s).

NiCad

Acronym for nickel cadmium.

NiMH

Abbreviation for nickel-metal hydride.

NLM

Acronym for NetWare[®] Loadable Module.

NMI

Abbreviation for nonmaskable interrupt. A device sends an NMI to signal the microprocessor about hardware errors, such as a parity error.

noninterlaced

A technique for decreasing screen flicker by sequentially refreshing each horizontal line on the screen.

ns

Abbreviation for nanosecond(s), one billionth of a second.

NTFS

Abbreviation for the NT File System option in the Windows NT operating system.

NVRAM

Abbreviation for nonvolatile random-access memory. Memory that does not lose its contents when you turn off your computer. NVRAM is used for maintaining the date, time, and system setup options.

OS/2

Abbreviation for Operating System/2.

OTP

Abbreviation for one-time programmable.

parallel port

An I/O port used most often to connect a parallel printer to your computer. You can usually identify a parallel port on your computer by its 25-hole connector.

parameter

A value or option that you specify to a program. A parameter is sometimes called a *switch* or an *argument*.

partition

You can divide a hard-disk drive into multiple physical sections called *partitions* with the **fdisk** command. Each partition can contain multiple logical drives. For example, you could partition a 200-MB hard-disk drive into two physically separate partitions with three logical drive assignments, as shown in the following table.

Partitioning the Hard-Disk Drive

Physical Partitions and Sizes	
Partition 1	120 MB
Partition 2	80 MB
Logical Drive Assignments and Sizes	
Drive C	120 MB
Drive D	50 MB
Drive E	30 MB

After partitioning the hard-disk drive, you must format each logical drive with the **format** command.

PC Card

Slightly larger than a credit card, a PC Card is a removable I/O card—such as a modem, LAN, SRAM, or flash memory card—that adheres to the PCMCIA standards. See also **PCMCIA**.

PCI

Abbreviation for Peripheral Component Interconnect. A standard for local-bus implementation developed by Intel Corporation.

PCMCIA

Abbreviation for Personal Computer Memory Card International Association. See also **PC Card**.

peripheral device

An internal or external device—such as a printer, a disk drive, or a keyboard—connected to a computer.

PGA

Abbreviation for pin grid array, a type of microprocessor socket that allows you to remove the microprocessor chip.

pixel

Arranged in rows and columns, a pixel is a single point on a video display. Video resolution—640 x 480, for example—is expressed as the number of pixels across by the number of pixels up and down.

POST

Acronym for power-on self-test. Before the operating system loads when you turn on your computer, the POST tests various system components such as RAM, the disk drives, and the keyboard.

ppm

Abbreviation for pages per minute.

PQFP

Abbreviation for plastic quad flat pack, a type of microprocessor socket in which the microprocessor chip is permanently mounted.

PRN

A synonym for the MS-DOS device name LPT1.

program diskette set

The set of diskettes from which you can perform a complete installation of an application program. When you reconfigure a program, you often need its program diskette set.

protected mode

An operating mode supported by 80286 or higher microprocessors, protected mode allows operating systems to implement:

- A memory address space of 16 MB (80286 microprocessor) to 4 GB (Intel386 or higher microprocessor)
- Multitasking
- Virtual memory, a method for increasing addressable memory by using the hard-disk drive

The Windows NT, OS/2, and UNIX® 32-bit operating systems run in protected mode. MS-DOS cannot run in protected mode; however, some programs that you can start from MS-DOS—such as Windows—are able to put the computer into protected mode.

PS/2

Abbreviation for Personal System/2.

PVC

Abbreviation for polyvinyl chloride.

QIC

Abbreviation for quarter-inch cartridge.

RAM

Acronym for random-access memory. The computer's primary temporary storage area for program instructions and data. Each location in RAM is identified by a number called a *memory address*. Any information stored in RAM is lost when you turn off your computer.

RAMDAC

Acronym for random-access memory digital-to-analog converter.

read-only file

A read-only file is one that you are prohibited from editing or deleting. A file can have read-only status if:

- Its read-only attribute is enabled.
- It resides on a physically write-protected diskette.
- It is located on a network in a directory to which the system administrator has assigned read-only rights to you.

real mode

An operating mode supported by 80286 or higher microprocessors, real mode imitates the architecture of an 8086 microprocessor. Designed to run in real mode, MS-DOS (unassisted by additional software techniques) can address only 640 KB of conventional memory.

refresh rate

The frequency, measured in Hz, at which the screen's horizontal lines are recharged. A monitor's refresh rate is also referred to as its *vertical frequency*.

REN

Abbreviation for ringer equivalence number.

RFI

Abbreviation for radio frequency interference.

RGB

Abbreviation for red/green/blue.

ROM

Acronym for read-only memory. Your computer contains some programs essential to its operation in ROM code. Unlike RAM, a ROM chip retains its contents even after you turn off your computer. Examples of code in ROM include the program that initiates your computer's boot routine and the POST.

rpm

Abbreviation for revolutions per minute.

RTC

Abbreviation for real-time clock. Battery-powered clock circuitry inside the computer that keeps the date and time after you turn off the computer.

SCSI

Acronym for small computer system interface. An I/O bus interface with faster data transmission rates than standard ports. You can connect up to seven devices to one SCSI interface.

SDMS

Abbreviation for SCSI device management system.

SECC

Abbreviation for single-edge connector cartridge.

sec

Abbreviation for second(s).

serial port

An I/O port used most often to connect a modem or a mouse to your computer. You can usually identify a serial port on your computer by its 9-pin connector.

shadowing

A computer's system and video BIOS code is usually stored on ROM chips. Shadowing refers to the performance-enhancement technique that copies BIOS code to faster RAM chips in the upper memory area (above 640 KB) during the boot routine.

SRAM

Abbreviation for static random-access memory. Because SRAM chips do not require continual refreshing, they are substantially faster than DRAM chips. SRAM is used mostly for external cache memory.

SVGA

Abbreviation for super video graphics array. See also **VGA**.

switch

See **parameter**.

sync negotiation

Sync negotiation is a SCSI feature that allows the host adapter and its attached SCSI devices to transfer data in synchronous mode. Synchronous data transfer is faster than asynchronous data transfer.

syntax

The rules that dictate how you must type a command or instruction so that the computer will understand it.

system board

As the main circuit board, the system board usually contains most of your computer's integral components, such as the following:

- Microprocessor
- RAM
- Expansion-card connectors
- Controllers for standard peripheral devices, such as the keyboard
- Various ROM chips

Frequently used synonyms for system board are *motherboard* and *logic board*.

system diskette

System diskette is a synonym for *bootable diskette*.

system memory

System memory is a synonym for *RAM*.

System Setup program

System Setup program options allow you to configure your computer's hardware. Some options in the System Setup program require that you reboot the computer in order to make a hardware-configuration change. Because the System Setup program is stored in NVRAM, any options that you set remain in effect until you change them again.

system.ini file

When you start Windows, it consults the **system.ini** file to determine a variety of options for the Windows operating

environment. Among other things, the **system.ini** file records which video, mouse, and keyboard drivers are installed for Windows.

Running the Control Panel or Windows Setup program may change options in the **system.ini** file. On other occasions, you may need to change or add options to the **system.ini** file manually with a text editor, such as Notepad.

terminator

Some devices, especially disk drives, contain a terminator to absorb and dissipate excess current. When more than one such device is connected in a series, you may need to remove the terminator—or change a jumper setting to disable it—unless it is the last device in the series. However, some devices have terminators that should never be removed or disabled.

text editor

An application program for editing text files consisting exclusively of ASCII characters. MS-DOS Editor and Notepad (in Windows) are text editors, for example. Most word processors use proprietary file formats containing binary characters, although some can read and write text files.

text mode

See **video mode**.

TFT

Abbreviation for thin film transistor. A flat-panel display for notebook computers where each pixel is controlled by one to four transistors.

tpi

Abbreviation for tracks per inch.

TSR

Abbreviation for terminate-and-stay-resident. A TSR program runs “in the background.” Most TSR programs implement a predefined key combination (sometimes referred to as a “hot key”) that allows you to activate the TSR program’s interface while running another MS-DOS program. When you finish using the TSR program, you can return to the other application program and leave the TSR program resident in memory for later use.

Because MS-DOS is not designed to support multiple programs running simultaneously, TSR programs can sometimes cause memory conflicts. When troubleshooting, rule out the possibility of such a conflict by rebooting your computer without starting any TSR programs.

TV

Abbreviation for television.

UL

Abbreviation for Underwriters Laboratories.

UMB

Abbreviation for upper memory blocks. See also **conventional memory**, **HMA**, **memory manager**, and **upper memory area**.

upper memory area

The 384 KB of RAM located between 640 KB and 1 MB. If the computer has an Intel386 or higher microprocessor, a software utility called a *memory manager* can create UMBs in the upper memory area, in which you can load device drivers and memory-resident programs. See also **conventional memory**, **HMA**, and **memory manager**.

UPS

Abbreviation for uninterruptible power supply. A battery-powered unit that automatically supplies power to your computer in the event of an electrical failure.

USOC

Abbreviation for Universal Service Ordering Code.

utility

A program used to manage system resources— memory, disk drives, or printers, for example. The **diskcopy** command for duplicating diskettes and the **himem.sys** device driver for managing extended memory are utilities included in MS-DOS.

V

Abbreviation for volt(s).

VAC

Abbreviation for volt(s) alternating current.

VCCI

Abbreviation for Voluntary Control Council for Interference.

VDC

Abbreviation for volt(s) direct current.

VDE

Abbreviation for *Verband Deutscher Elektrotechniker*.

VDS

Abbreviation for Virtual Direct Memory Access Services.

VESA®

Acronym for Video Electronics Standards Association.

VGA

Abbreviation for video graphics array. VGA and SVGA are video standards for video adapters with greater resolution and color display capabilities than EGA and CGA, the previous standards.

To display a program at a specific resolution, you must install the appropriate video drivers and your monitor must support the resolution. Similarly, the number of colors that a program can display depends on the capabilities of the monitor, the video driver, and the amount of memory installed for the video adapter.

VGA feature connector

On some systems with a built-in VGA video adapter, a VGA feature connector allows you to add an enhancement adapter, such as a video accelerator, to your computer. A VGA feature connector can also be called a *VGA pass-through connector*.

video adapter

The logical circuitry that provides—in combination with the monitor or display—your computer's video capabilities. A video adapter may support more or fewer features than a specific monitor offers. Typically, a video adapter comes with video drivers for displaying popular application programs and operating environments in a variety of video modes.

On most current Dell computers, a video adapter is integrated into the system board. Also available are many video adapter cards that plug into an expansion-card connector.

Video adapters can include memory separate from RAM on the system board. The amount of video memory, along with the adapter's video drivers, may affect the number of colors that can be simultaneously displayed. Video adapters can also include their own coprocessor chip for faster graphics rendering.

video driver

Graphics-mode application programs and operating environments, such as Windows, often require video drivers in order to display at a chosen resolution with the desired number of colors. A program may include some "generic" video drivers. Any additional video drivers may need to match the video adapter; you can find these drivers on a separate diskette with your computer or video adapter.

video memory

Most VGA and SVGA video adapters include VRAM or DRAM memory chips in addition to your computer's RAM. The amount of video memory installed primarily influences the number of colors that a program can display (with the appropriate video drivers and monitor capability).

video mode

Video adapters normally support multiple text and graphics display modes. Character-based software (such as MS-DOS) displays in text modes that can be defined as x columns by y rows of characters. Graphics-based software (such as Windows) displays in graphics modes that can be defined as x horizontal by y vertical pixels by z colors.

video resolution

Video resolution—640 x 480, for example—is expressed as the number of pixels across by the number of pixels up and down. To display a program at a specific graphics resolution, you must install the appropriate video drivers and your monitor must support the resolution.

virtual 8086 mode

An operating mode supported by Intel386 or higher microprocessors, virtual 8086 mode allows operating environments—such as Windows—to run multiple programs in separate 1-MB sections of memory. Each 1-MB section is called a *virtual machine*.

virtual memory

A method for increasing addressable RAM by using the hard-disk drive. (MS-DOS does not support true virtual memory, which must be implemented at the operating system level.) For example, in a computer with 8 MB of RAM and 16 MB of virtual memory set up on the hard-disk drive, the operating system would manage the system as though it had 24 MB of physical RAM.

virus

A self-starting program designed to inconvenience you. Virus programs have been known to corrupt the files stored on a hard-disk drive or to replicate themselves until a system or network runs out of memory.

The most common way that virus programs move from one system to another is via “infected” diskettes, from which they copy themselves to the hard-disk drive. To guard against virus programs, you should do the following:

- Periodically run a virus-checking utility on your computer’s hard-disk drive
- Always run a virus-checking utility on any diskettes (including commercially sold software) before using them

VL-Bus™

An abbreviation for VESA local bus. A standard for local bus implementation developed by the Video Electronics Standards Association.

VLSI

Abbreviation for very-large-scale integration.

Vpp

Abbreviation for peak-point voltage.

VRAM

Abbreviation for video random-access memory. Some video adapters use VRAM chips (or a combination of VRAM and DRAM) to improve video performance. VRAM is dual-ported, allowing the video adapter to update the screen and receive new image data at the same time.

W

Abbreviation for watt(s).

win.ini file

When you start Windows, it consults the **win.ini** file to determine a variety of options for the Windows operating environment. Among other things, the **win.ini** file records what printer(s) and fonts are installed for Windows. The **win.ini** file also usually includes sections that contain optional settings for Windows application programs that are installed on the hard-disk drive.

Running the Control Panel or Windows Setup program may change options in the **win.ini** file. On other occasions, you may need to change or add options to the **win.ini** file manually with a text editor, such as Notepad.

write-protected

Read-only files are said to be *write-protected*. You can write-protect a 3.5-inch diskette by sliding its write-protect tab to the open position and a 5.25-inch diskette by placing an adhesive label over its write-protect notch.

XMM

Abbreviation for extended memory manager, a utility that allows application programs and operating environments to use extended memory in accordance with the XMS. See also **conventional memory**, **EMM**, **expanded memory**, **extended memory**, and **memory manager**.

XMS

Abbreviation for eXtended Memory Specification. See also **EMS**, **extended memory**, and **memory manager**.

ZIF

Acronym for zero insertion force. Some computers use ZIF sockets and connectors to allow devices such as the micro-processor chip to be installed or removed with no stress applied to the device.

Index

A

- access
 - diskette drive, 4-10
- adapter
 - 50-pin to 68-pin, 8-7
- adding memory, 7-5
- asset tag number
 - assigning, 2-3
 - deleting, 2-3
- asset tag utility, 2-2
- assigning a supervisor password, 4-12
- assigning a user password, 4-14
- assistance, technical, 1-4
- autoconfiguration
 - parallel port, B-6
 - serial ports, B-6

B

- backup devices, C-1
- basic input/output system. See BIOS
- battery
 - checking and replacing, 7-10
- beep codes, F-5
- BIOS
 - shadowing memory, 4-4
 - video, 4-4

- boot device
 - configuring, 9-3
- booting the computer system, 4-4
- built-in SCSI controller, 1-2

C

- cables
 - 50-pin to 68-pin adapter, 8-7
 - control panel, 6-4
 - diskette drive interface, 6-4, 8-5
 - drive power, 8-4
 - external drives, 8-2
 - hard-disk drive power, 6-5
 - SCSI, 6-4, 9-3
- cache
 - secondary, 1-1
- cache memory
 - turning on and off, 4-4
- cautions, x
- cleaning
 - accessories, C-2
 - drives, C-3
 - internal components, C-2
 - solutions, C-2
 - system exterior, C-2
 - tools, C-2
- COM port designations, B-5

- computer
 - cleaning, C-2
 - cover removal/replacement, 6-2
 - features, 1-1
 - interior illustrated, 6-4, 6-5
- configuration guidelines
 - SCSI drives, 9-1
- configuration jumpers
 - list of, B-3
 - location, 7-1
 - on system board, B-2
- connectors
 - AC power input, 6-5
 - back panel, 6-5, B-5
 - DC power cables, 8-4
 - descriptions, B-4
 - drive power, 8-4
 - header, 8-4
 - on system board, 7-1
- controls and indicators
 - front panel, 1-3
- cooling fan, 6-4

D

- data
 - backups, C-1
 - loss and recovery, C-1
 - recovery tools, C-2
- DC power cables
 - about, 6-3
 - drive connectors, 8-4
 - power input connectors, 8-3
- diagnosing problems, 1-4
- diagnostics
 - diskette-based, 1-2

- DIMMs
 - about, 1-1, 7-5
 - installing, 7-7
 - removing, 7-8
 - sample configurations, 7-6
 - sockets, 7-1, 7-5
- direct current. See DC
- disabling a forgotten password, 4-15
- diskette drive interface cable, 8-5
- diskette drives
 - access control, 4-10
 - cable, 8-5
 - cleaning, C-3
 - head-cleaning kit, C-2
 - installing, 8-5
 - types, sizes, and capacities, 4-4
- diskette-based diagnostics, 1-2
- drive access indicator, 1-3
- drive bays
 - external, 6-4, 6-5, 8-1, 8-2
 - internal, 9-4, 9-5
- drive cage
 - removing, 9-5
- drives
 - attaching rails, 8-5
 - boot device, 9-1, 9-3
 - external bays, 8-3, 8-5
 - header connector, 8-4
 - installing in external bays, 8-4
 - installing in internal bays, 9-1, 9-5
 - jumpers, 8-1
 - power cables, 8-4
 - SCSI cable, 9-3
 - SCSI configuration guidelines, 9-1
 - SCSI external bays, 8-6
 - SCSI ID numbers, 9-1
 - SCSI termination jumpers, 9-2
 - specifications, A-2
- dual in-line memory modules. See DIMMs

E

ECC, 1-1

EISA

- expansion slots, 1-2
- jumper, B-3
- system board options, 5-9

EISA Configuration Utility

- about, 5-1
- Advanced menu, 5-10
- exiting, 5-10
- ISA cards without configuration files, 5-2
- Main menu, 5-4
- making selections, 5-3
- Modeling mode, 5-12
- multiple configurations, 5-12
- online instructions, 5-3
- password features, 5-13
- program diskettes, 5-2
- resolving resource conflicts, 5-11
- starting, 5-3
- Steps in Configuring Your Computer menu, 5-4
- System Board Options screen, 5-9
- when to run, 5-2

electrostatic discharge. *See* ESD

error correction code. *See* ECC

error messages, F-1

ESD, vii, C-4

expansion bus

- specifications, A-1

expansion cards

- about, 7-2
- adding, 5-5
- configuring, 5-1
- conflict resolution, 5-11
- illustrated, 7-2
- installing, 7-3
- locking and unlocking, 5-10
- removing, 5-6, 7-4
- repositioning, 5-6

expansion cards (*continued*)

- types supported, 7-2
- with ports, B-6

expansion slots

- about, 7-3

exterior cleaning of system, C-2

external drive bay cables, 8-2

external drive bays, 6-4, 6-5, 8-1

EZ-SCSI

- installing, 3-8

F

fan

- cooling, 6-4

features

- system, 1-1

filler bracket

- illustrated, 7-3
- removing, 7-3

forgotten password

- disabling, 4-15, 5-16

front bezel

- removal and replacement, 6-2

front panel

- controls and indicators, 1-3
- illustrated, 1-3
- inserts, 8-2

G

getting help, 1-4

grounding procedure, 6-1

grounding strap, C-2

H

- hard-disk drive cage
 - internal bays, 9-5
 - location, 6-4
 - removing, 9-5
- hard-disk drives
 - cleaning, C-3
 - data recovery, C-1
- hardware options
 - unpacking, 6-3
- help tools, 1-4

I

- I/O ports and connectors, B-5
- ID numbers
 - SCSI devices, 9-1
- indicators
 - drive access, 1-3
- indicators on front panel, 1-3
- Industry-Standard Architecture. See ISA
- input/output. See I/O
- inside your computer
 - precautions, 6-1
- interface cables
 - about, 6-3
- internal bay drives
 - installing, 9-1
 - location, 9-4
- interrupt request. See IRQ
- IRQ line, B-6
- ISA expansion slots, 7-3

J

- jumpers
 - 233MHZ, B-3
 - 266MHZ, B-3
 - about, B-1
 - CARDBIOS, B-3
 - EISA, B-3
 - list of, B-3
 - on drives, 8-1
 - on system board, 7-1
 - PASSWD, B-3
 - speed, 7-10
 - system board, B-2
 - VGA, B-3

K

- keyboard
 - cleaning, C-2
- keylock
 - about, 1-4
 - operation, 6-2

L

- line conditioners
 - preventing power source interruptions, C-6
- LPT port designations, B-5

M

- memory
 - about, 1-1
 - adding, 7-5
 - caching, 4-4
 - configuring, 7-5

memory (*continued*)

- sample configurations, 7-6
- shadowing, 4-4
- specifications, A-1
- upgrading, 7-6

messages

- help information in System Setup program, 4-2
- system error, F-1

metal inserts

- removing, 8-3

microprocessor

- features, 1-1
- heat sink removal and replacement, 7-9
- jumper settings for speed, 7-10
- module, 7-9
- socket, 7-1
- socket release lever, 7-9
- speed jumpers, B-3
- speeds, 1-1
- type supported, 1-1
- types supported, 1-1, A-1
- upgrading, 7-8

modeling mode, 5-12

monitor

- cleaning, C-2

mounting plate

- system board, 6-4

mouse connector

- about, B-7

mouse connector pin assignments, B-8

N

NetWare

- approved drives, 3-15
- calculating slot number, 3-9
- command line options, 3-11
- error codes, 3-16

NetWare (*continued*)

- installation overview, 3-8
- installing 4.x, 3-10
- installing drivers, 3-9
- mount status, 3-14
- optimizing performance, 3-16
- sample load command, 3-12
- SCSI driver installation, 3-7
- troubleshooting, 3-16
- using a CD-ROM, 3-15
- using SCSI devices, 3-13
- using the tape backup utility, 3-15

NetWare error codes, 3-16

notational conventions, x

O

operating systems, 1-3

options

- password, 4-16

orientation

- system, 6-2, 7-2

P

parallel port

- about, B-5
- configuring, B-6
- designations, B-5
- IRQ line, B-6
- pin assignments, B-7

password

- disabling a forgotten, 4-15, 5-16
- entering wrong, 4-14
- features, 4-12
- on boot, 4-10
- options, 4-16
- supervisor, 4-10, 4-12, 5-14

password (*continued*)
user, 4-10, 4-13, 5-15
using, 4-12

PCI expansion slots, 1-2

Peripheral Component Interconnect. See PCI

ports
adding expansion cards with, B-6
connecting external devices, 1-3
designations, B-5
illustrated, B-5

power
button, 1-3
DC power cables, 6-3
indicator, 1-3
input connectors on drives, 8-4
protection devices, C-6
surges and spikes, C-5

power source interruptions
preventing, C-5

power supply, 6-4

precautions
inside your computer, 6-1

problem solving, 1-4

R

recovering data
tools, C-2

regulatory notices, D-1

removing and replacing
computer cover, 6-2
front bezel, 6-2
system board assembly, 6-6

reset button, 1-3

resolutions
video, 1-2

resource conflicts
resolving, 5-11
return policy, E-4

S

safety instructions
for preventing ESD, vii
general, v
health considerations, v, 6-1

safety warning, 6-1

SCSI controller
built-in, 9-1
optional, 8-7

SCSI devices
boot files, 3-13
booting from, 3-13
ID numbers, 9-1
using, 3-13

SCSI disk utilities, 3-5

SCSI drivers
included with system, 3-1
installing for NetWare, 3-7
installing for Windows NT, 3-5

SCSISelect utility
advanced host adapter settings, 3-3
boot device settings, 3-2
default settings, 3-1
exiting, 3-5
host adapter settings, 3-2
SCSI device settings, 3-3
starting, 3-4
using menus, 3-5
using the SCSI disk utilities, 3-5

security
keylock, 1-4
password features, 4-12, 5-13
system, 1-4

- serial ports
 - about, B-5
 - configuring, B-6
 - designations, B-5
 - IRQ lines, B-6
 - pin assignments, B-6
- Server Assistant CD
 - about, 2-1
 - booting system from, 2-1
 - installing video drivers from, 2-2
 - main menu, 2-1
 - using online manuals, 2-1
- server management features, 1-2
- service, 1-4
- shadowing memory, 4-4
- small computer system interface. See SCSI
- sockets
 - descriptions, B-4
 - on system board, 7-1
- specifications
 - system, A-1
- speed jumpers
 - setting, 7-10
- supervisor password
 - assigning, 4-12, 5-14
 - changing, 4-13, 5-14
 - deleting, 4-13
 - description, 4-12, 5-13
 - operating with, 4-13
- support, 1-4
- surge protector
 - preventing power source interruptions, C-6
- system
 - orientation, 6-2, 7-2
- system battery
 - replacing, 7-10
 - socket, 7-1
- system board
 - about, 6-3
 - assembly removal and replacement, 6-6
 - connectors and sockets, 7-1, B-4
 - features, 1-2
 - jumpers, B-2
 - location, 6-4, 6-5
 - mounting plate, 6-4
 - options in EISA Configuration Utility, 5-6, 5-7
- system configuration information, 4-1, 5-1
- system diagnostics
 - running, F-6
- system environment
 - altitude, C-4
 - corrosion, C-4
 - dust, C-4
 - EMI and RFI, C-4
 - ESD, C-4
 - humidity, C-3
 - magnetism, C-5
 - power source, C-5
 - shock and vibration, C-5
 - temperature, C-3
- system features, 1-1
- system memory
 - adding, 7-5
 - sample configurations, 7-6
 - upgrading, 7-6
- system security, 1-4
- System Setup program
 - about, 4-1
 - Advanced menu categories, 4-7
 - Advanced menu screen, 4-7
 - Boot Options submenu categories, 4-5
 - Boot Options submenu screen, 4-5
 - configuration options, 4-1
 - entering, 4-3
 - Exit menu categories, 4-11
 - Exit menu screen, 4-11
 - exiting, 4-12

System Setup program (*continued*)

- help information, 4-2
 - key functions, 4-2
 - Main menu categories, 4-4
 - Main menu screen, 4-3
 - screens, 4-1
 - Security menu categories, 4-9
 - Security menu screen, 4-9
 - system configuration information, 4-1
 - system data, 4-1
 - title box, 4-1
- system specifications, A-1

- upgrade options
 - expansion cards, 7-3
 - memory, 7-6
 - microprocessor, 7-8
 - unpacking, 6-3

UPS, C-6

- user password
 - assigning, 4-14, 5-15
 - changing, 4-15, 5-15
 - deleting, 4-15, 5-15
 - description, 4-13
 - operating with, 4-14

T

tape drives

- backing up data, C-1
- capacities supported, A-2
- cleaning, C-3
- installing, 8-4

technical assistance, 1-4

termination jumpers

- SCSI drives, 9-2

tools

- cleaning, C-2

troubleshooting

- general, 1-4
- NetWare, 3-16
- Windows NT, 3-7

U

uninterruptible power supply. *See* UPS

unpacking hardware options, 6-3

V

video

- connector pin assignments, B-8
- drivers, 2-2
- installing drivers, 2-2
- memory size, 1-2
- resolutions, 1-2
- subsystem, 1-2

W

warnings, x

warranty information, x, E-1

Windows NT

- installing SCSI drivers, 3-5
- installing video drivers, 2-2
- removing a host adapter, 3-6
- swapping a host adapter, 3-7
- troubleshooting, 3-7
- updating drivers, 3-6