

Intel[®] Core[™] i5-600, i3-500 Desktop Processor Series and Intel[®] Pentium[®] Desktop Processor 6000 Series

Datasheet – Volume 2

January 2011



INFORMATION IN THIS DOCUMENT IS PROVIDED IN CONNECTION WITH INTEL® PRODUCTS. NO LICENSE, EXPRESS OR IMPLIED, BY ESTOPPEL OR OTHERWISE, TO ANY INTELLECTUAL PROPERTY RIGHTS IS GRANTED BY THIS DOCUMENT. EXCEPT AS PROVIDED IN INTEL'S TERMS AND CONDITIONS OF SALE FOR SUCH PRODUCTS, INTEL ASSUMES NO LIABILITY WHATSOEVER, AND INTEL DISCLAIMS ANY EXPRESS OR IMPLIED WARRANTY, RELATING TO SALE AND/OR USE OF INTEL PRODUCTS INCLUDING LIABILITY OR WARRANTIES RELATING TO FITNESS FOR A PARTICULAR PURPOSE, MERCHANTABILITY, OR INFRINGEMENT OF ANY PATENT, COPYRIGHT OR OTHER INTELLECTUAL PROPERTY RIGHT. Intel products are not intended for use in medical, life saving, life sustaining, critical control or safety systems, or in nuclear facility applications.

Intel may make changes to specifications and product descriptions at any time, without notice.

Designers must not rely on the absence or characteristics of any features or instructions marked "reserved" or "undefined." Intel reserves these for future definition and shall have no responsibility whatsoever for conflicts or incompatibilities arising from future changes to them.

The Intel Core™ i7-800 and i5-700 desktop processor series and Intel Pentium desktop processor 6000 series may contain design defects or errors known as errata which may cause the product to deviate from published specifications. Current characterized errata are available on request.

^AIntel processor numbers are not a measure of performance. Processor numbers differentiate features within each processor family, not across different processor families. See http://www.intel.com/products/processor_number for details. Over time processor numbers will increment based on changes in clock, speed, cache, FSB, or other features, and increments are not intended to represent proportional or quantitative increases in any particular feature. Current roadmap processor number progression is not necessarily representative of future roadmaps. See www.intel.com/products/processor_number for details.

No computer system can provide absolute security under all conditions. Intel® Trusted Execution Technology (Intel® TXT) requires a computer system with Intel® Virtualization Technology, an Intel TXT-enabled processor, chipset, BIOS, Authenticated Code Modules and an Intel TXT-compatible measured launched environment (MLE). The MLE could consist of a virtual machine monitor, an OS or an application. In addition, Intel TXT requires the system to contain a TPM v1.2, as defined by the Trusted Computing Group and specific software for some uses. For more information, see <http://www.intel.com/technology/security/>.

Intel® Virtualization Technology requires a computer system with an enabled Intel® processor, BIOS, virtual machine monitor (VMM) and, for some uses, certain platform software enabled for it. Functionality, performance or other benefits will vary depending on hardware and software configurations and may require a BIOS update. Software applications may not be compatible with all operating systems. Please check with your application vendor.

Intel® Active Management Technology requires the computer system to have an Intel(R) AMT-enabled chipset, network hardware and software, as well as connection with a power source and a corporate network connection. Setup requires configuration by the purchaser and may require scripting with the management console or further integration into existing security frameworks to enable certain functionality. It may also require modifications of implementation of new business processes. With regard to notebooks, Intel AMT may not be available or certain capabilities may be limited over a host OS-based VPN or when connecting wirelessly, on battery power, sleeping, hibernating or powered off. For more information, see www.intel.com/technology/platform-technology/intel-amt/

Enabling Execute Disable Bit functionality requires a PC with a processor with Execute Disable Bit capability and a supporting operating system. Check with your PC manufacturer on whether your system delivers Execute Disable Bit functionality.

Contact your local Intel sales office or your distributor to obtain the latest specifications and before placing your product order.

Copies of documents which have an order number and are referenced in this document, or other Intel literature may be obtained by calling 1-800-548-4725 or by visiting Intel's website at <http://www.intel.com>.

Intel, Intel Core, Intel Scalable Memory Interconnect (Intel SMI), Intel Virtualization Technology for Directed I/O, Intel Trusted Execution Technology (Intel TXT), Intel Management Engine (Intel ME), Intel Interconnect BIST (Intel IBIST), and the Intel logo are trademarks of Intel Corporation in the U. S. and other countries.

*Other names and brands may be claimed as the property of others.

Copyright © 2011 Intel Corporation. All Rights Reserved.



Contents

1	Introduction	13
2	Processor Configuration Registers	15
2.1	Register Terminology	15
2.2	System Address Map	17
2.2.1	Legacy Address Range	19
2.2.1.1	DOS Range (0000_0000h – 0009_FFFFh)	19
2.2.1.2	Legacy Video Area (000A_0000h – 000B_FFFFh)	19
2.2.1.3	PAM (000C_0000h-000F_FFFFh)	20
2.2.2	Main Memory Address Range (1MB – TOLUD)	21
2.2.2.1	ISA Hole (15 MB – 16 MB)	21
2.2.2.2	TSEG	22
2.2.2.3	Protected Memory Range (PMR) – (programmable)	22
2.2.2.4	DRAM Protected Range (DPR)	23
2.2.2.5	Pre-allocated Memory	23
2.2.2.6	Graphics Stolen Spaces	23
2.2.2.7	Intel® Management Engine (Intel® ME) UMA	24
2.2.2.8	PCI Memory Address Range (TOLUD – 4 GB)	24
2.2.2.9	APIC Configuration Space (FEC0_0000h–FECF_FFFFh)	26
2.2.2.10	High BIOS Area	26
2.2.3	Main Memory Address Space (4 GB to TOUUD)	27
2.2.3.1	Programming Model	28
2.2.4	PCI Express* Configuration Address Space	33
2.2.5	PCI Express* Graphics Attach (PEG)	33
2.2.6	Graphics Memory Address Ranges	34
2.2.6.1	IOBAR Mapped Access to Device 2 MMIO Space	34
2.2.7	System Management Mode (SMM)	35
2.2.8	SMM and VGA Access through GTT TLB	35
2.2.9	I/O Address Space	35
2.2.9.1	PCI Express* I/O Address Mapping	36
2.3	Configuration Process and Registers	37
2.3.1	Platform Configuration Structure	37
2.4	Configuration Mechanisms	38
2.4.1	Standard PCI Configuration Mechanism	38
2.4.2	PCI Express* Enhanced Configuration Mechanism	39
2.4.3	Routing Configuration Accesses	40
2.4.4	Internal Device Configuration Accesses	41
2.4.5	Bridge Related Configuration Accesses	42
2.4.5.1	PCI Express* Configuration Accesses	42
2.4.5.2	DMI Configuration Accesses	43
2.5	Processor Register Introduction	43
2.6	I/O Mapped Registers	44
2.7	PCI Express* Device 0 Registers	45
2.7.1	VID—Vendor Identification Register	46
2.7.2	DID—Device Identification Register	46
2.7.3	PCICMD—PCI Command Register	47
2.7.4	PCISTS—PCI Status Register	48
2.7.5	RID—Revision Identification	49
2.7.6	CC—Class Code Register	49
2.7.7	MLT—Master Latency Timer Register	49
2.7.8	HDR—Header Type Register	50
2.7.9	SVID—Subsystem Vendor Identification Register	50
2.7.10	SID—Subsystem Identification Register	51
2.7.11	PXPEPBAR—PCI Express Egress Port Base Address Register	51



2.7.12	MCHBAR—MCH Memory Mapped Register Range Base Register	52
2.7.13	GGC—Graphics Control Register	53
2.7.14	DEVEN—Device Enable Register	54
2.7.15	DMIBAR—Root Complex Register Range Base Address Register	55
2.7.16	LAC—Legacy Access Control Register	56
2.7.17	TOUUD—Top of Upper Usable DRAM Register	58
2.7.18	GBSM— Graphics Base of Pre-allocated Memory Register	58
2.7.19	BGSM—Base of GTT Pre-allocated Memory Register	59
2.7.20	TSEGMB—TSEG Memory Base Register	59
2.7.21	TOLUD—Top of Low Usable DRAM Register	60
2.7.22	PBFC—Primary Buffer Flush Control Register	61
2.7.23	SBFC—Secondary Buffer Flush Control Register	61
2.7.24	ERRSTS—Error Status Register	62
2.7.25	ERRCMD—Error Command Register	63
2.7.26	SMICMD—SMI Command Register	64
2.7.27	SKPD—Scratchpad Data Register	64
2.7.28	CAPID0—Capability Identifier Register	65
2.7.29	MCSAMPML—Memory Configuration, System Address Map and Pre-allocated Memory Lock Register	65
2.8	MCHBAR Registers	66
2.8.1	CSZMAP—Channel Size Mapping Register	68
2.8.2	CHDECMISC—Channel Decode Miscellaneous Register	69
2.8.3	CODRBO—Channel 0 DRAM Rank Boundary Address 0 Register	70
2.8.4	CODRB1—Channel 0 DRAM Rank Boundary Address 1 Register	71
2.8.5	CODRB2—Channel 0 DRAM Rank Boundary Address 2 Register	71
2.8.6	CODRB3—Channel 0 DRAM Rank Boundary Address 3 Register	72
2.8.7	CODRA01—Channel 0 DRAM Rank 0,1 Attribute Register	73
2.8.8	CODRA23—Channel 0 DRAM Rank 2,3 Attribute Register	74
2.8.9	COWRDATACTRL—Channel 0 Write Data Control Register	74
2.8.10	COCYCTRKPCHG—Channel 0 CYCTRK PCHG Register	75
2.8.11	COCYCTRKACT—Channel 0 CYCTRK ACT Register	76
2.8.12	COCYCTRKWR—Channel 0 CYCTRK WR Register	77
2.8.13	COCYCTRKRd—Channel 0 CYCTRK READ Register	77
2.8.14	COCYCTRKREFR—Channel 0 CYCTRK REFR Register	78
2.8.15	COPWLRCTRL—Channel 0 Partial Write Line Read Control Register	78
2.8.16	COREFRCTRL—Channel 0 DRAM Refresh Control Register	79
2.8.17	COJEDEC—Channel 0 JEDEC Control Register	81
2.8.18	COODT—Channel 0 ODT Matrix Register	82
2.8.19	COODTCTRL—Channel 0 ODT Control Register	84
2.8.20	CODTC—Channel 0 DRAM Throttling Control Register	84
2.8.21	CORSTCTL—Channel 0 Reset Controls Register	85
2.8.22	C1DRBO—Channel 1 DRAM Rank Boundary Address 0 Register	86
2.8.23	C1DRB1—Channel 1 DRAM Rank Boundary Address 1 Register	86
2.8.24	C1DRB2—Channel 1 DRAM Rank Boundary Address 2 Register	86
2.8.25	C1DRB3—Channel 1 DRAM Rank Boundary Address 3 Register	87
2.8.26	C1DRA01—Channel 1 DRAM Rank 0,1 Attributes Register	87
2.8.27	C1DRA23—Channel 1 DRAM Rank 2, 3 Attributes Register	87
2.8.28	C1WRDATACTRL—Channel 1 Write Data Control Register	88
2.8.29	C1CYCTRKPCHG—Channel 1 CYCTRK PCHG Register	88
2.8.30	C1CYCTRKACT—Channel 1 CYCTRK ACT Register	89
2.8.31	C1CYCTRKWR—Channel 1 CYCTRK WR Register	90
2.8.32	C1CYCTRKRd—Channel 1 CYCTRK READ Register	90
2.8.33	C1CKECTRL—Channel 1 CKE Control Register	91
2.8.34	C1PWLRCTRL—Channel 1 Partial Write Line Read Control Register	92
2.8.35	C1ODTCTRL—Channel 1 ODT Control Register	92
2.8.36	C1DTC—Channel 1 DRAM Throttling Control Register	93



2.8.37	SSKPD—Sticky Scratchpad Data Register	94
2.8.38	TSC1—Thermal Sensor Control 1 Register	94
2.8.39	TSS1—Thermal Sensor Status 1 Register.....	95
2.8.40	TR1—Thermometer Read 1 Register	95
2.8.41	TOF1—Thermometer Offset 1 Register	96
2.8.42	RTR1—Relative Thermometer Read 1 Register.....	96
2.8.43	TSTTPA1—Thermal Sensor Temperature Trip Point A1 Register.....	97
2.8.44	TSTTPB1—Thermal Sensor Temperature Trip Point B1 Register.....	98
2.8.45	TS10BITMCTRL—Thermal Sensor 10-bit Mode Control Register.....	98
2.8.46	HWTHROTCTRL1—Hardware Throttle Control 1 Register	99
2.8.47	TIS1—Thermal Interrupt Status 1 Register	100
2.8.48	TERATE—Thermometer Mode Enable and Rate Register	102
2.8.49	TERRCMD—Thermal Error Command Register	103
2.8.50	TSMICMD—Thermal SMI Command Register	104
2.8.51	TSCICMD—Thermal SCI Command Register	105
2.8.52	TINTRCMD—Thermal INTR Command Register	106
2.8.53	EXTTSCS—External Thermal Sensor Control and Status Register	107
2.8.54	DDRMPLL1—DDR PLL BIOS Register	109
2.9	EPBAR Registers.....	110
2.9.1	EPPVCCAP1—EP Port VC Capability Register 1	110
2.9.2	EPPVCCCTL—EP Port VC Control Register.....	110
2.9.3	EPVCCORCTL—EP VC 0 Resource Control Register.....	111
2.9.4	EPVCCORCAP—EP VC 0 Resource Capability Register	112
2.9.5	EPVCC1RCTL—EP VC 1 Resource Control Register.....	113
2.9.6	EPVCC1RSTS—EP VC 1 Resource Status Register.....	114
2.10	PCI Device 1 Registers	115
2.10.1	VID1—Vendor Identification Register	117
2.10.2	DID1—Device Identification Register.....	117
2.10.3	PCICMD1—PCI Command Register.....	117
2.10.4	PCISTS1—PCI Status Register.....	119
2.10.5	RID1—Revision Identification Register.....	120
2.10.6	CC1—Class Code Register.....	120
2.10.7	CL1—Cache Line Size Register	121
2.10.8	HDR1—Header Type Register	121
2.10.9	PBUSN1—Primary Bus Number Register	121
2.10.10	SBUSN1—Secondary Bus Number Register	122
2.10.11	SUBUSN1—Subordinate Bus Number Register	122
2.10.12	IOBASE1—I/O Base Address Register.....	123
2.10.13	IOLIMIT1—I/O Limit Address Register	123
2.10.14	SSTS1—Secondary Status Register.....	124
2.10.15	MBASE1—Memory Base Address Register	125
2.10.16	MLIMIT1—Memory Limit Address Register	126
2.10.17	PMBASE1—Prefetchable Memory Base Address Register	127
2.10.18	PMLIMIT1—Prefetchable Memory Limit Address Register.....	128
2.10.19	PMBASEU1—Prefetchable Memory Base Address Upper Register	128
2.10.20	PMLIMITU1—Prefetchable Memory Limit Address Upper Register.....	129
2.10.21	CAPPTR1—Capabilities Pointer Register	129
2.10.22	INTRLINE1—Interrupt Line Register	130
2.10.23	INTRPIN1—Interrupt Pin Register	130
2.10.24	BCTRL1—Bridge Control Register.....	131
2.10.25	MSAC—Multi Size Aperture Control Register	132
2.10.26	PM_CAPID1—Power Management Capabilities Register	133
2.10.27	PM_CS1—Power Management Control/Status Register.....	134
2.10.28	SS_CAPID—Subsystem ID and Vendor ID Capabilities Register.....	135
2.10.29	SS—Subsystem ID and Subsystem Vendor ID Register.....	135
2.10.30	MSI_CAPID—Message Signaled Interrupts Capability ID Register	136



2.10.31	MC—Message Control Register	137
2.10.32	MA—Message Address Register	138
2.10.33	MD—Message Data Register	138
2.10.34	PEG_CAPL—PCI Express-G Capability List Register	138
2.10.35	PEG_CAP—PCI Express-G Capabilities Register	139
2.10.36	DCAP—Device Capabilities Register	139
2.10.37	DCTL—Device Control Register	140
2.10.38	DSTS—Device Status Register	141
2.10.39	LCAP—Link Capabilities Register	142
2.10.40	CTL—Link Control Register	144
2.10.41	LSTS—Link Status Register	146
2.10.42	SLOTCAP—Slot Capabilities Register	148
2.10.43	SLOTCTL—Slot Control Register	149
2.10.44	SLOTSTS—Slot Status Register	151
2.10.45	RCTL—Root Control Register	153
2.10.46	RSTS—Root Status Register	154
2.10.47	LCTL2—Link Control 2 Register	154
2.10.48	LSTS2—Link Status 2 Register	155
2.10.49	PEGLC—PCI Express* Legacy Control Register	155
2.11	Device 1 Extended Configuration Registers	156
2.11.1	PVCCAP1—Port VC Capability Register 1	156
2.11.2	PVCCAP2—Port VC Capability Register 2	157
2.11.3	PVCCTL—Port VC Control Register	157
2.11.4	VCORCAP—VC0 Resource Capability Register	158
2.11.5	VCORCTL—VC0 Resource Control Register	158
2.11.6	VCORSTS—VC0 Resource Status Register	159
2.11.7	PEG_TC—PCI Express Completion Timeout Register	160
2.12	DMIBAR Registers	161
2.12.1	DMIVCECH—DMI Virtual Channel Enhanced Capability Register	161
2.12.2	DMIPVCCAP1—DMI Port VC Capability Register 1	162
2.12.3	DMIPVCCAP2—DMI Port VC Capability Register 2	162
2.12.4	DMIPVCCCTL—DMI Port VC Control Register	163
2.12.5	DMIVCORCAP—DMI VC0 Resource Capability Register	163
2.12.6	DMIVCORCTL0—DMI VC0 Resource Control Register	164
2.12.7	DMIVCORSTS—DMI VC0 Resource Status Register	165
2.12.8	DMIVC1RCAP—DMI VC1 Resource Capability Register	165
2.12.9	DMIVC1RCTL1—DMI VC1 Resource Control Register	166
2.12.10	DMIVC1RSTS—DMI VC1 Resource Status Register	167
2.12.11	DMIVCPRCTL—DMI VCp Resource Control Register	168
2.12.12	DMIVCPRSTS—DMI VCp Resource Status Register	169
2.12.13	DMIESD—DMI Element Self Description Register	169
2.12.14	DMILE1D—DMI Link Entry 1 Description Register	170
2.12.15	DMILE1A—DMI Link Entry 1 Address Register	170
2.12.16	DMILE2D—DMI Link Entry 2 Description Register	171
2.12.17	DMILE2A—DMI Link Entry 2 Address Register	171
2.12.18	DMILCAP—DMI Link Capabilities Register	172
2.12.19	DMILCTL—DMI Link Control Register	173
2.12.20	DMILSTS—DMI Link Status Register	173
2.13	PCI Device 2, Function 0 Registers	174
2.13.1	VID2—Vendor Identification Register	174
2.13.2	DID2—Device Identification Register	175
2.13.3	PCICMD2—PCI Command Register	175
2.13.4	PCISTS2—PCI Status Register	176
2.13.5	RID2—Revision Identification Register	177
2.13.6	CC—Class Code Register	177
2.13.7	CLS—Cache Line Size Register	178



2.13.8	MLT2—Master Latency Timer Register	178
2.13.9	HDR2—Header Type Register	178
2.13.10	GTTMMADR—Graphics Translation Table, Memory Mapped Range Address Register	179
2.13.11	GMADR—Graphics Memory Range Address Register	180
2.13.12	IOBAR—I/O Base Address Register	181
2.13.13	SVID2—Subsystem Vendor Identification Register	181
2.13.14	SID2—Subsystem Identification Register	182
2.13.15	ROMADR—Video BIOS ROM Base Address Register	182
2.13.16	INTRPIN—Interrupt Pin Register	182
2.13.17	MINGNT—Minimum Grant Register	183
2.13.18	MAXLAT—Maximum Latency Register	183
2.14	Device 2 I/O Registers	183
2.14.1	Index—MMIO Address Register	184
2.14.2	Data—MMIO Data Register	184
2.15	DMI and PEG VC0/VCp Remap Registers.....	185
2.15.1	VER_REG—Version Register	186
2.15.2	CAP_REG—Capability Register.....	187
2.15.3	ECAP_REG—Extended Capability Register	190
2.15.4	GCMD_REG—Global Command Register.....	191
2.15.5	GSTS_REG—Global Status Register.....	194
2.15.6	RTADDR_REG—Root-Entry Table Address Register.....	195
2.15.7	CCMD_REG—Context Command Register.....	196
2.15.8	FSTS_REG—Fault Status Register	198
2.15.9	FECTL_REG—Fault Event Control Register.....	199
2.15.10	FEDATA_REG—Fault Event Data Register.....	200
2.15.11	FEADDR_REG—Fault Event Address Register.....	200
2.15.12	FEUADDR_REG—Fault Event Upper Address Register.....	200
2.15.13	AFLOG_REG—Advanced Fault Log Register	201
2.15.14	PMEM_REG—Protected Memory Enable Register	202
2.15.15	PLMBASE_REG—Protected Low-Memory Base Register	203
2.15.16	PLMLIMIT_REG—Protected Low-Memory Limit Register.....	204
2.15.17	PHMBASE_REG—Protected High-Memory Base Register	205
2.15.18	PHMLIMIT_REG—Protected High-Memory Limit Register	206
2.15.19	IQH_REG—Invalidation Queue Head Register	206
2.15.20	IQT_REG—Invalidation Queue Tail Register.....	207
2.15.21	IQA_REG—Invalidation Queue Address Register	207
2.15.22	ICS_REG—Invalidation Completion Status Register	208
2.15.23	IECTL_REG—Invalidation Event Control Register.....	208
2.15.24	IEDATA_REG—Invalidation Event Data Register.....	209
2.15.25	IEADDR_REG—Invalidation Event Address Register.....	209
2.15.26	IEUADDR_REG—Invalidation Event Upper Address Register.....	210
2.15.27	IRTA_REG—Interrupt Remapping Table Address Register.....	210
2.15.28	IWA_REG—Invalidate Address Register	211
2.15.29	IOTLB_REG—IOTLB Invalidate Register	212
2.15.30	FRCD_REG—Fault Recording Registers	214
2.15.31	VTCMPLRESR—VT Completion Resource Dedication.....	215
2.15.32	VTFTCHARBCTL—VC0/VCp VTd Fetch Arbiter Control.....	216
2.15.33	PEGVTCMPLRESR—PEG VT Completion Resource Dedication	217
2.15.34	VTPOLICY—DMA Remap Engine Policy Control.....	219
2.16	DMI VC1 REMAP Registers	221
2.16.1	VER_REG—Version Register	222
2.16.2	CAP_REG—Capability Register.....	223
2.16.3	ECAP_REG—Extended Capability Register	225
2.16.4	GCMD_REG—Global Command Register.....	227
2.16.5	GSTS_REG—Global Status Register.....	230



2.16.6	RTADDR_REG—Root-Entry Table Address Register	231
2.16.7	CCMD_REG—Context Command Register	232
2.16.8	FSTS_REG—Fault Status Register	234
2.16.9	FECTL_REG—Fault Event Control Register	235
2.16.10	FEDATA_REG—Fault Event Data Register	236
2.16.11	FEADDR_REG—Fault Event Address Register	236
2.16.12	FEUADDR_REG—Fault Event Upper Address Register	237
2.16.13	AFLOG_REG—Advanced Fault Log Register	237
2.16.14	PMEN_REG—Protected Memory Enable Register	238
2.16.15	PLMBASE_REG—Protected Low-Memory Base Register	239
2.16.16	PLMLIMIT_REG—Protected Low-Memory Limit Register	240
2.16.17	PHMBASE_REG—Protected High-Memory Base Register	241
2.16.18	PHMLIMIT_REG—Protected High-Memory Limit Register	242
2.16.19	IOH_REG—Invalidation Queue Head Register	243
2.16.20	IQT_REG—Invalidation Queue Tail Register	243
2.16.21	IQA_REG—Invalidation Queue Address Register	244
2.16.22	ICS_REG—Invalidation Completion Status Register	244
2.16.23	IECTL_REG—Invalidation Event Control Register	245
2.16.24	IEDATA_REG—Invalidation Event Data Register	246
2.16.25	IEADDR_REG—Invalidation Event Address Register	246
2.16.26	IEUADDR_REG—Invalidation Event Upper Address Register	247
2.16.27	IRTA_REG—Interrupt Remapping Table Address Register	247
2.16.28	IWA_REG—Invalidate Address Register	248
2.16.29	IOTLB_REG—IOTLB Invalidate Register	249
2.16.30	FRCD_REG—Fault Recording Registers	251
2.16.31	VTPOLICY—DMA Remap Engine Policy Control	252
2.17	Graphics Control Registers	253
2.17.1	MGGC—Graphics Control Register	253
2.17.2	GFXPLL1—GFX PLL BIOS	254
2.18	GFXVTBAR Registers	255
2.18.1	VER_REG—Version Register	256
2.18.2	CAP_REG—Capability Register	257
2.18.3	ECAP_REG—Extended Capability Register	260
2.18.4	GCMD_REG—Global Command Register	261
2.18.5	GSTS_REG—Global Status Register	264
2.18.6	RTADDR_REG—Root-Entry Table Address Register	266
2.18.7	CCMD_REG—Context Command Register	266
2.18.8	FSTS_REG—Fault Status Register	268
2.18.9	FECTL_REG—Fault Event Control Register	270
2.18.10	FEDATA_REG—Fault Event Data Register	271
2.18.11	FEADDR_REG—Fault Event Address Register	271
2.18.12	FEUADDR_REG—Fault Event Upper Address Register	271
2.18.13	AFLOG_REG—Advanced Fault Log Register	272
2.18.14	PMEN_REG—Protected Memory Enable Register	273
2.18.15	PLMBASE_REG—Protected Low Memory Base Register	274
2.18.16	PLMLIMIT_REG—Protected Low Memory Limit Register	275
2.18.17	PHMBASE_REG—Protected High Memory Base Register	276
2.18.18	PHMLIMIT_REG—Protected High Memory Limit Register	277
2.18.19	IOH_REG—Invalidation Queue Head Register	278
2.18.20	IQT_REG—Invalidation Queue Tail Register	278
2.18.21	IQA_REG—Invalidation Queue Address Register	279
2.18.22	ICS_REG—Invalidation Completion Status Register	279
2.18.23	IECTL_REG—Invalidation Completion Event Control Register	280
2.18.24	IEDATA_REG—Invalidation Completion Event Data Register	281
2.18.25	IEUADDR_REG—Invalidation Completion Event Upper Address Register	281
2.18.26	IRTA_REG—Interrupt Remapping Table Address Register	282



2.18.27	IVA_REG—Invalidate Address Register	283
2.18.28	IOTLB_REG—IOTLB Invalidate Register	284
2.18.29	FRCD_REG—Fault Recording Registers	286
2.18.30	VTPOICY—VT Policy Register	287
2.19	PCI Device 6 Registers	288
2.19.1	VID6—Vendor Identification Register	289
2.19.2	DID6—Device Identification Register	290
2.19.3	PCICMD6—PCI Command Register	290
2.19.4	PCISTS6—PCI Status Register	292
2.19.5	RID6—Revision Identification Register	293
2.19.6	CC6—Class Code Register	293
2.19.7	CL6—Cache Line Size Register	294
2.19.8	HDR6—Header Type Register	294
2.19.9	PBUSN6—Primary Bus Number Register	294
2.19.10	SBUSN6—Secondary Bus Number Register	295
2.19.11	SUBUSN6—Subordinate Bus Number Register	295
2.19.12	IOBASE6—I/O Base Address Register	296
2.19.13	IOLIMIT6—I/O Limit Address Register	296
2.19.14	SSTS6—Secondary Status Register	297
2.19.15	MBASE6—Memory Base Address Register	298
2.19.16	MLIMIT6—Memory Limit Address Register	299
2.19.17	PMBASE6—Prefetchable Memory Base Address Register	300
2.19.18	PMLIMIT6—Prefetchable Memory Limit Address Register	301
2.19.19	PMBASEU6—Prefetchable Memory Base Address Upper Register	302
2.19.20	PMLIMITU6—Prefetchable Memory Limit Address Upper Register	303
2.19.21	CAPPTR6—Capabilities Pointer Register	303
2.19.22	INTRLINE6—Interrupt Line Register	304
2.19.23	INTRPIN6—Interrupt Pin Register	304
2.19.24	BCTRL6—Bridge Control Register	304
2.19.25	PM_CAPID6—Power Management Capabilities Register	306
2.19.26	PM_CS6—Power Management Control/Status Register	307
2.19.27	SS_CAPID—Subsystem ID and Vendor ID Capabilities Register	308
2.19.28	SS—Subsystem ID and Subsystem Vendor ID Register	308
2.19.29	MSI_CAPID—Message Signaled Interrupts Capability ID Register	309
2.19.30	MC—Message Control Register	310
2.19.31	MA—Message Address Register	311
2.19.32	MD—Message Data Register	311
2.19.33	PEG_CAPL—PCI Express-G Capability List Register	311
2.19.34	PEG_CAP—PCI Express-G Capabilities Register	312
2.19.35	DCAP—Device Capabilities Register	312
2.19.36	DCTL—Device Control Register	313
2.19.37	DSTS—Device Status Register	314
2.19.38	LCAP—Link Capabilities Register	315
2.19.39	LCTL—Link Control Register	317
2.19.40	LSTS—Link Status Register	319
2.19.41	SLOTCAP—Slot Capabilities Register	320
2.19.42	SLOTCTL—Slot Control Register	322
2.19.43	SLOTSTS—Slot Status Register	324
2.19.44	RCTL—Root Control Register	326
2.19.45	RSTS—Root Status	327
2.19.46	PEGLC—PCI Express-G Legacy Control Register	327
2.20	Device 6 Extended Configuration Registers	328
2.20.1	PVCCAP1—Port VC Capability Register 1	328
2.20.2	PVCCAP2—Port VC Capability Register 2	329
2.20.3	PVCCCTL—Port VC Control Register	329
2.20.4	VCORCAP—VC0 Resource Capability Register	330



2.20.5	VCORCTL—VCO Resource Control Register	331
2.20.6	VCORSTS—VCO Resource Status Register	332
2.21	Intel® Trusted Execution Technology (Intel® TXT) Specific Registers	332
2.21.1	TXT.DID—TXT Device ID Register	333
2.21.2	TXT.DPR—DMA Protected Range Register	333
2.21.3	TXT.PUBLIC.KEY.LOWER—TXT Processor Public Key Hash Lower Half Register	334
2.21.4	TXT.PUBLIC.KEY.UPPER—TXT Processor Public Key Hash Upper Half Register	334
3	Intel® QuickPath Architecture System Address Decode Register Description	335
3.1	Register Terminology	335
3.2	Platform Configuration Structure	337
3.3	Detailed Configuration Space Maps	338
3.4	PCI Standard Registers	342
3.4.1	VID—Vendor Identification Register	342
3.4.2	DID—Device Identification Register	342
3.4.3	RID—Revision Identification Register	343
3.4.4	CCR—Class Code Register	344
3.4.5	HDR—Header Type Register	345
3.4.6	SID/SVID—Subsystem Identity/Subsystem Vendor Identification Register ..	345
3.4.7	PCICMD—Command Register	346
3.4.8	PCISTS—PCI Status Register	347
3.5	Generic Non-core Registers	349
3.5.1	MAX_RTIDS	349
3.6	SAD—System Address Decoder Registers	349
3.6.1	SAD_PAM0123	349
3.6.2	SAD_PAM456	351
3.6.3	SAD_HEN	352
3.6.4	SAD_SMRAM	353
3.6.5	SAD_PCIEXBAR	354
3.6.6	SAD_DRAM_RULE_0, SAD_DRAM_RULE_1, SAD_DRAM_RULE_2, SAD_DRAM_RULE_3, SAD_DRAM_RULE_4, SAD_DRAM_RULE_5, SAD_DRAM_RULE_6, SAD_DRAM_RULE_7	355
3.7	Intel® QPI Link Registers	356
3.7.1	QPI_QPILCL_L0, QPI_QPILCL_L1	356
3.8	Intel® QPI Physical Layer Registers	357
3.8.1	QPI_0_PH_CPR, QPI_1_PH_CPR	357
3.8.2	QPI_0_PH_CTR, QPI_1_PH_CTR	358
3.8.3	QPI_0_PH_PIS, QPI_1_PH_PIS	359



Figures

2-1	System Address Range	18
2-2	DOS Legacy Address Range	19
2-3	Main Memory Address Range	21
2-4	PCI Memory Address Range	25
2-5	Case 1 — Less than 4 GB of Physical Memory (no remap)	29
2-6	Case 2 — Greater than 4 GB of Physical Memory	30
2-7	4 GB or Less of Physical Memory	31
2-8	Greater than 4 GB, Remap Enabled.....	32
2-9	Memory Map to PCI Express Device Configuration Space	39
2-10	Processor Configuration Cycle Flow Chart	41

Tables

2-1	Register Terminology	15
2-2	SMM Regions	35
2-3	Device Number Assignment for Internal Processor Devices.....	38
2-4	PCI Express* Device 0 Register Address Map	45
2-5	MCHBAR Register Address Map	66
2-6	DRAM Rank Attribute Register Programming	73
2-7	PCI Express* Device 1 Register Address Map	115
2-8	Device 1 Extended Configuration Register Address Map	156
2-9	DMI Register Address Map.....	161
2-10	PCI (Device 2, Function 0) Register Address Map.....	174
2-11	MMI and PEG VC0/VCp Remap Register Address Map	185
2-12	DMI VC1 Remap Register Address Map.....	221
2-13	GFXVTBAR Register Address Map.....	255
2-14	PCI Device 6 Register Address Map.....	288
2-15	Device 6 Extended Configuration Register Address Map	328
2-16	Intel® TXT Register Address Map.....	332
3-1	Register Terminology	335
3-2	Functions Specifically Handled by the Processor	337
3-3	Device 0, Function 0 — Generic Non-core Registers	338
3-4	Device 0, Function 1 — System Address Decoder Registers	339
3-5	Device 2, Function 0 — Intel® QPI Link 0 Registers.....	340
3-6	Device 2, Function 1 — Intel® QPI Physical 0 Registers	341



Revision History

Revision Number	Description	Revision Date
-001	Initial release	January 2010
-002	<ul style="list-style-type: none">Added the MCSAMPML—Memory Configuration, System Address Map and Pre-allocated Memory Lock Register. See Section 2.7.28.Added the PEG_TC—PCI Express Completion Timeout Register. See Section 2.11.7.Updated the system address map section, and main memory address space for better clarification	November 2010
-003	<ul style="list-style-type: none">Added the series designation “Intel® Pentium® desktop processor 6000 series”.Added the Intel® Pentium® processor G6960.	January 2011

§



1 Introduction

This is Volume 2 of the Datasheet for the Intel® Core™ i5-600, i3-500 Desktop processor series and Intel® Pentium® desktop processor 6000 series.

The processor contains one or more PCI devices within a single physical component. The configuration registers for these devices are mapped as devices residing on the PCI Bus assigned for the processor socket. This document describes these configuration space registers or device-specific control and status registers (CSRs) only. This document does NOT include Model Specific Registers (MSRs).

Note: Throughout this document, the Intel® Core™ i5-600, i3-500 Desktop processor series and Intel® Pentium® desktop processor 6000 series may be referred to as “processor”.

Note: Throughout this document, the Intel® 5 series Chipset Platform Controller Hub is also referred to as “PCH”.

Note: The term “DT” refers to desktop platforms.

§





2 Processor Configuration Registers

2.1 Register Terminology

Table 2-1 shows the register-related terminology that is used in this chapter.

Table 2-1. Register Terminology (Sheet 1 of 2)

Item	Description
RO	Read Only bit(s) . Writes to these bits have no effect. These are static values only.
RO-V	Read Only/Volatile bit(s) . Writes to these bits have no effect. These are status bits only. The value to be read may change based on internal events.
RO-V-S	Read Only/Volatile/Sticky bit(s) . Writes to these bits have no effect. These are status bits only. The value to be read may change based on internal events. Bits are not returned to their Reset Values by "warm" reset, but is reset with a cold/complete reset (for PCI Express* related bits a cold reset is "Power Good Reset" as defined in the <i>PCI Express Base Specification</i>).
AF	Atomic Flag bit(s) . The first time the bit is read with an enabled byte, it returns the value 0, but a side-effect of the read is that the value changes to 1. Any subsequent reads with enabled bytes return a 1 until a 1 is written to the bit. When the bit is read, but the byte is not enabled, the state of the bit does not change, and the value returned is irrelevant, but will match the state of the bit. When a 0 is written to the bit, there is no effect. When a 1 is written to the bit, its value becomes 0, until the next byte-enabled read. When the bit is written, but the byte is not enabled, there is no effect. Conceptually, this is "Read to Set, Write 1 to Clear"
RW	Read/Write bit(s) . These bits can be read and written by software. Hardware may only change the state of this bit by reset.
RW1C	Read/Write 1 to Clear bit(s) . These bits can be read. Internal events may set this bit. A software write of 1 clears (sets to 0) the corresponding bit(s) and a write of 0 has no effect.
RW1C-L-S	Read/Write 1 to Clear/Lockable/Sticky bit(s) . These bits can be read. Internal events may set this bit. A software write of 1 clears (sets to 0) the corresponding bit(s) and a write of 0 has no effect. Bits are not cleared by "warm" reset, but is reset with a cold/complete reset (for PCI Express related bits a cold reset is "Power Good Reset" as defined in the PCI Express Base spec). Additionally there is a Key bit (which is marked RW-K or RW-L-K) that, when set, prohibits this bit field from being writable (bit field becomes Read Only/Volatile).
RW1C-S	Read/Write 1 to Clear/Sticky bit(s) . These bits can be read. Internal events may set this bit. A software write of 1 clears (sets to 0) the corresponding bit(s) and a write of 0 has no effect. Bits are not cleared by "warm" reset, but is reset with a cold/complete reset (for PCI Express related bits a cold reset is "Power Good Reset" as defined in the PCI Express Base spec).
RW-K	Read/Write/Key bit(s) . These bits can be read and written by software. Additionally this bit, when set, prohibits some other target bit field from being writable (bit fields become Read Only).
RW-L	Read/Write/Lockable bit(s) . These bits can be read and written by software. Additionally there is a Key bit (which is marked RW-K or RW-L-K) that, when set, prohibits this bit field from being writable (bit field becomes Read Only).
RW-L-K	Read/Write/Lockable/Key bit(s) . These bits can be read and written by software. This bit, when set, prohibits some other bit field(s) from being writable (bit fields become Read Only). Additionally there is a Key bit (which is marked RW-K or RW-L-K) that, when set, prohibits this bit field from being writable (bit field becomes Read Only). Conceptually, this may be a cascaded lock, or it may be self-locking when in its non-default state. When self-locking, it differs from RW-O in that writing back the Reset Value will not set the lock.
RW-V	Write/Volatile bit(s) . These bits can be read and written by software. Hardware may set or clear the bit based on internal events, possibly sooner than any subsequent software read could retrieve the value written.



Table 2-1. Register Terminology (Sheet 2 of 2)

Item	Description
RW-V-L	Read/Write/Volatile/Lockable bit(s) . These bits can be read and written by software. Hardware may set or clear the bit based upon internal events, possibly sooner than any subsequent software read could retrieve the value written. Additionally, there is a bit (which is marked RW-K or RW-L-K) that, when set, prohibits this bit field from being writable (bit field becomes Read Only).
RW-V-L-S	Read/Write/Volatile/Lockable/Sticky bit(s) . These bits can be read and written by software. Hardware may set or clear the bit based upon internal events, possibly sooner than any subsequent software read could retrieve the value written. Additionally, there is a bit (which is marked RW-K or RW-L-K) that, when set, prohibits this bit field from being writable (bit field becomes Read Only). These bits return to their Reset Values on cold reset.
RW-S	Read/Write/Sticky bit(s) . These bits can be read and written by software. Bits are not returned to their Reset Values by "warm" reset, but will return to Reset Values with a cold/complete reset (for PCI Express related bits a cold reset is "Power Good Reset" as defined in the PCI Express spec).
RW-O	Read/Write Once bit(s) . Reads prior to the first write return the Reset Value. The first write after warm reset stores any value written. Any subsequent write to this bit field is ignored. All subsequent reads return the first value written. The value returns to default on warm reset. If there are multiple RW-O or RW-O-S fields within a DWORD, they should be written all at once (atomically) to avoid capturing an incorrect value.
RW-O-S	Read/Write Once/Sticky bit(s) . Reads prior to the first write return the Reset Value. The first write after cold reset stores any value written. Any subsequent write to this bit field is ignored. All subsequent reads return the first value written. The value returns to default on cold reset. If there are multiple RW-O or RW-O-S fields within a DWORD, they should be written all at once (atomically) to avoid capturing an incorrect value.
W	Write-only . These bits may be written by software, but will always return zeros when read. They are used for write side-effects. Any data written to these registers cannot be retrieved.
W1C	Write 1 to Clear-only . These bits may be cleared by software by writing a 1. Writing a 0 has no effect. The state of the bits cannot be read directly. The states of such bits are tracked outside the processor and all read transactions to the address of such bits are routed to the other agent. Write transactions to these bits go to both agents.
MBZ	Must Be Zero when writing this bit.



2.2 System Address Map

Note: The processor's Multi Chip Package (MCP) conceptually consists of the processor and the north bridge chipset (GMCH) combined together in a single package. Hence, this section will have references to the processor as well as GMCH (or MCH) address mapping.

The MCP supports 64 GB (36 bit) of addressable memory space and 64 KB+3 of addressable I/O space. With the new QPI interface, the processor performs decoding that historically occurred within the GMCH. Specifically, the GMCH address decoding for processor initiated PAM, 15 MB–16 MB ISA hole, SMM CSEG/TSEG, PCIexBAR, and DRAM accesses will occur within the processor and the GMCH has no direct knowledge. In addition, the ME (device 3) will move to the PCH, so ME associated register ranges have been removed from the graphics controller. This section focuses on how the memory space is partitioned and what the separate memory regions are used for. I/O address space has simpler mapping and is explained near the end of this section.

The MCP supports PEG port upper prefetchable base/limit registers. This allows the PEG unit to claim IO accesses above 36 bit, complying with the PCI Express Base Specification 2.1. Addressing of greater than 4 GB is allowed on either the DMI Interface or PCI Express interface. The MCP supports a maximum of 16 GB of DRAM. No DRAM memory will be accessible above 16 GB. DRAM capacity is limited by the number of address pins available.

When running in internal graphics mode, TileX/TileY/linear reads/writes to GMADR range are supported. Write accesses to GMADR linear regions are supported from both DMI and PEG. GMADR write accesses to tileX and tileY regions (defined using fence registers) are not supported from DMI or the PEG port. GMADR read accesses are not supported from either DMI or PEG.

In the following sections, it is assumed that all of the compatibility memory ranges reside on the DMI Interface. The exception to this rule is VGA ranges, which may be mapped to PCI Express*, or DMI, or to the internal graphics device (IGD). In the absence of more specific references, cycle descriptions referencing PCI should be interpreted as the DMI Interface/PCI, while cycle descriptions referencing PCI Express or IGD are related to the PCI Express bus or the internal graphics device respectively. The processor does not remap APIC or any other memory spaces above TOLUD (Top of Low Usable DRAM). The TOLUD register is set to the appropriate value by BIOS. The remapbase/remaplimit registers remap logical accesses bound for addresses above 4 GB onto physical addresses that fall within DRAM.



Figure 2-1 represents system memory address map in a simplified form.

Figure 2-1. System Address Range

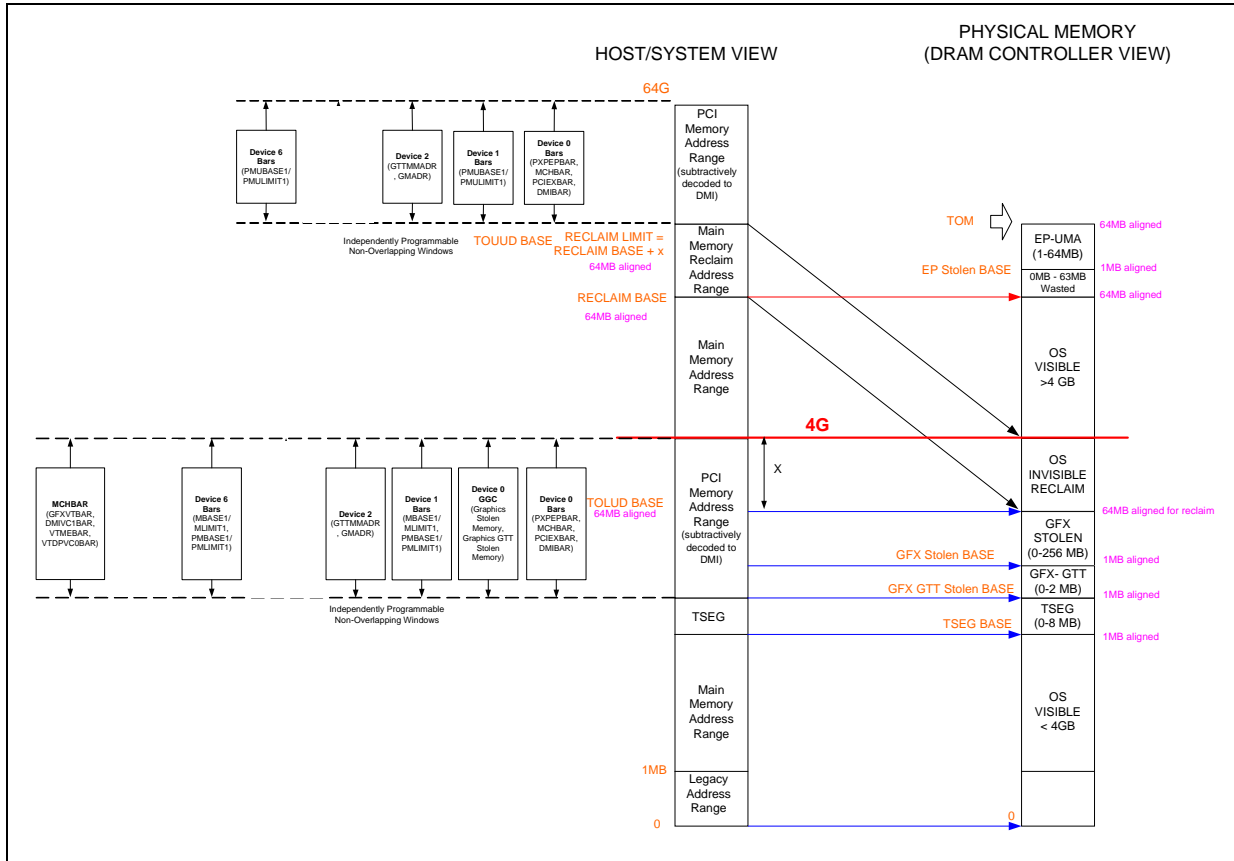



2.2.1 Legacy Address Range

This area is divided into the following address regions:

- 0 – 640 KB — DOS Area
- 640 – 768 KB — Legacy Video Buffer Area
- 768 – 896 KB in 16 KB sections (total of 8 sections) — Expansion Area
- 896 – 960 KB in 16 KB sections (total of 4 sections) — Extended System BIOS Area
- 960 KB – 1 MB Memory — System BIOS Area

Figure 2-2. DOS Legacy Address Range

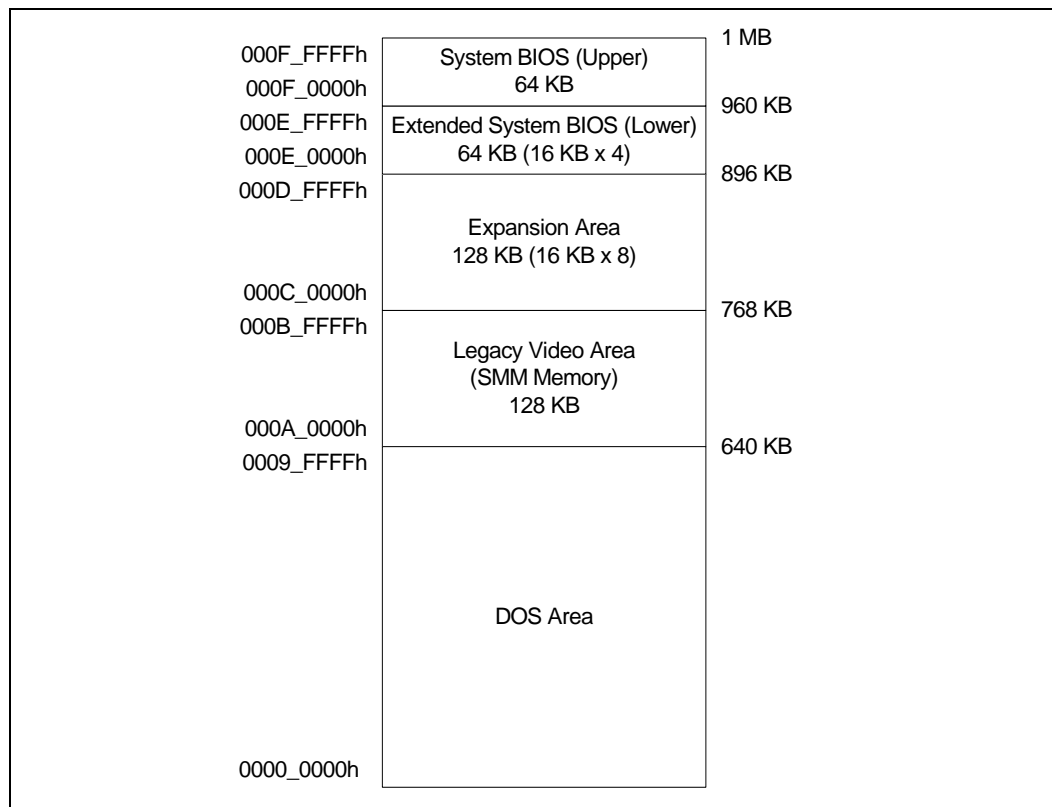

2.2.1.1 DOS Range (0000_0000h – 0009_FFFFh)

The DOS area is 640 KB (0000_0000h – 0009_FFFFh) in size and is always mapped to the main memory controlled by the processor.

2.2.1.2 Legacy Video Area (000A_0000h – 000B_FFFFh)

The legacy 128 KB VGA memory range, frame buffer, (000A_0000h – 000B_FFFFh) can be mapped to IGD (Device 2), to PCI Express (Device 1), and/or to the DMI Interface. The appropriate mapping depends on which devices are enabled and the programming of the VGA steering bits. Based on the VGA steering bits, priority for VGA mapping is constant. The processor always decodes internally mapped devices first. Internal to the processor, decode priority is:

1. IGD
2. PCI Express
3. DMI Interface (subtractive)



Non-SMM-mode processor accesses to this range are considered to be to the Video Buffer Area as described above. The processor will route these accesses on the non-coherent (NCS or NCB) channels.

The processor always positively decodes internally mapped devices, namely the IGD and PCI-Express. Subsequent decoding of regions mapped to PCI Express or the DMI Interface depends on the Legacy VGA configuration bits (VGA Enable and MDAP). This region is also the default for SMM space.

Compatible SMRAM Address Range (000A_0000h – 000B_FFFFh)

Unlike FSB platforms, the Intel® Core™ i5-600, i3-500 Desktop processor series and Intel® Pentium® desktop processor 6000 series see no SMM indication with processor accesses. When compatible SMM space is enabled, SMM-mode processor accesses to this range route to physical system DRAM at 000A_0000h – 000B_FFFFh. The processor performs the decode and routes the access to physical system DRAM. In other words, an SMM-mode processor access to this range will be sent on the HOM QPI channel.

PCI Express and DMI originated cycles to enabled SMM space are not allowed and are considered to be to the Video Buffer Area, if IGD is not enabled as the VGA device. DMI initiated writes cycles are attempted as peer writes cycles to a VGA enabled PCIe port.

Monochrome Adapter (MDA) Range (000B_0000h – 000B_7FFFh)

Legacy support requires the ability to have a second graphics controller (monochrome) in the system. Accesses in the standard VGA range are forwarded to IGD, PCI-Express, or the DMI Interface (depending on configuration bits). Since the monochrome adapter may be mapped to any of these devices, the processor must decode cycles in the MDA range (000B_0000h – 000B_7FFFh) and forward either to IGD, PCI-Express, or the DMI Interface. This capability is controlled by a VGA steering bits and the legacy configuration bit (MDAP bit). In addition to the memory range B0000h to B7FFFh, the processor decodes I/O cycles at 3B4h, 3B5h, 3B8h, 3B9h, 3BAh and 3BFh and forwards them to the either IGD, PCI-Express, and/or the DMI Interface.

2.2.1.3 PAM (000C_0000h-000F_FFFFh)

The 13 sections from 768 KB to 1 MB comprise what is also known as the PAM Memory Area. Each section has Read enable and Write enable attributes. The processor documentation will now contain the registers and decode rules/restrictions.

The PAM registers have moved to the processor. For the PAM register details, refer to processor documentation.

- ISA Expansion Area (000C_0000h – 000D_FFFFh)
- Extended System BIOS Area (000E_0000h – 000E_FFFFh)
- System BIOS Area (000F_0000h – 000F_FFFFh)

The processor contains the PAM registers and the GMCH has no knowledge of the register programming. The processor decodes the request and routes to the appropriate destination (DRAM or DMI) by sending the request on HOM or NCS/NCB.

Snooped accesses from PCI Express or DMI to this region are snooped on QPI.

Non-snooped accesses from PCI Express or DMI to this region are always sent to DRAM. Graphics translated requests to this region are not allowed. If such a mapping error occurs, the request will be routed to 000C_0000h. Writes will have the byte enables de-asserted.



2.2.2 Main Memory Address Range (1MB – TOLUD)

This address range extends from 1 MB to the top of Low Usable physical memory that is permitted to be accessible by the GMCH (as programmed in the TOLUD register). The processor will route all addresses within this range as HOM accesses, which will be forwarded by the GMCH to the DRAM unless it falls into the optional TSEG, optional ISA Hole, or optional IGD stolen VGA memory.

Figure 2-3. Main Memory Address Range

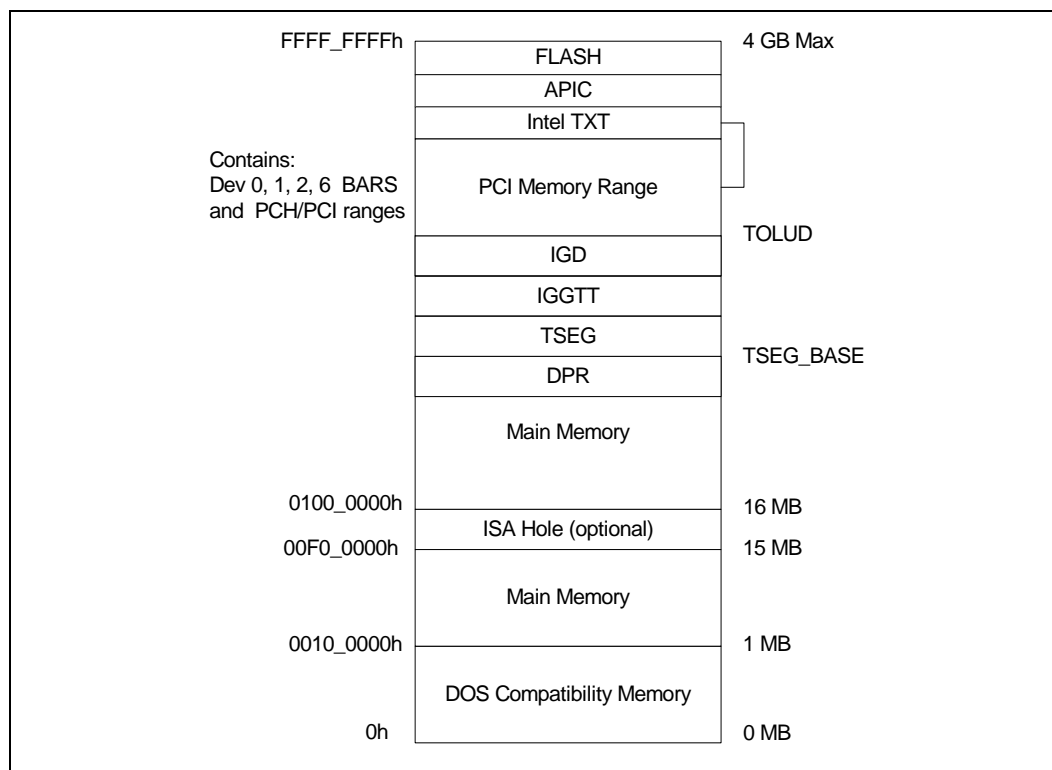

2.2.2.1 ISA Hole (15 MB – 16 MB)

This register moved to the processor. As such, the processor performs the necessary decode and routes the request appropriately. Specifically, if no hole is created, the processor will route the request to DRAM (HOM channel). If a hole is created, the processor will route the request on NCS/NCB, since the request does not target DRAM.

Graphics translated requests to the range will always route to DRAM.



2.2.2.2 TSEG

The TSEG register was moved from the GMCH to the processor. The GMCH will have no direct knowledge of the TSEG size. For processor initiated transactions, the processor will perform necessary decode and route appropriately on HOM (to DRAM) or NCS/NCB.

TSEG is below IGD stolen memory, which is at the Top of Low Usable physical memory (TOLUD). When SMM is enabled, the maximum amount of memory available to the system is equal to the amount of physical DRAM minus the value in the TSEG register. BIOS will calculate and program a register, so the GMCH has knowledge of where $(TOLUD) - (Gfx\ stolen) - (Gfx\ GTT\ stolen) - (TSEG)$ is located. This is indicated by the TSEG_BASE register.

SMM-mode processor accesses to enabled TSEG access the physical DRAM at the same address. The processor will route these accesses on the QPI HOM channel.

When the extended SMRAM space is enabled, processor accesses to the TSEG range without SMM attribute or without WB attribute are handled by the processor as invalid accesses. Refer to the processor documentation for how the processor handles these accesses.

Non- processor originated accesses are not allowed to SMM space. PCI-Express, DMI, and Internal Graphics originated cycle to enabled SMM space are handled as invalid cycle type with reads and writes to location 0 and byte enables turned off for writes.

2.2.2.3 Protected Memory Range (PMR) – (programmable)

For robust and secure launch of the MVMM, the MVMM code and private data needs to be loaded to a memory region protected from bus master accesses. Support for protected memory region is required for DMA-remapping hardware implementations on platforms supporting Intel® Trusted Execution Technology (Intel TXT), and is optional for non-Intel TxT platforms. Since the protected memory region needs to be enabled before the MVMM is launched, hardware must support enabling of the protected memory region independently from enabling the DMA-remapping hardware.

As part of the secure launch process, the SINIT-AC module verifies the protected memory regions are properly configured and enabled. Once launched, the MVMM can setup the initial DMA-remapping structures in protected memory (to ensure they are protected while being setup) before enabling the DMA-remapping hardware units.

To optimally support platform configurations supporting varying amounts of main memory, the protected memory region is defined as two non-overlapping regions:

- **Protected Low-memory Region:** This is defined as the protected memory region below 4 GB to hold the MVMM code/private data, and the initial DMA-remapping structures that control DMA to host physical addresses below 4 GB. DMA-remapping hardware implementations on platforms supporting Intel TXT are required to support protected low-memory region 5.
- **Protected High-memory Region:** This is defined as a variable sized protected memory region above 4 GB, enough to hold the initial DMA-remapping structures for managing DMA accesses to addresses above 4 GB. DMA-remapping hardware implementations on platforms supporting Intel TXT are required to support protected high-memory region 6, if the platform supports main memory above 4 GB.



Once the protected low/high memory region registers are configured, bus master protection to these regions is enabled through the Protected Memory Enable register. For platforms with multiple DMA-remapping hardware units, each of the DMA-remapping hardware units must be configured with the same protected memory regions and enabled.

2.2.2.4 DRAM Protected Range (DPR)

This protection range only applies to DMA accesses and GMADR translations. It serves a purpose of providing a memory range that is only accessible to processor streams.

The DPR range works independent of any other range, including the PMRC checks in VTd. It occurs post any VTd translation. Therefore, incoming cycles are checked against this range after the VTd translation and faulted if they hit this protected range, even if they passed the VTd translation.

The system will set up:

1. 0 to (TSEG_BASE – DPR size – 1) for DMA traffic
2. TSEG_BASE to (TSEG_BASE – DPR size) as no DMA

After some time, software could request more space for not allowing DMA. It will get some more pages and make sure there are no DMA cycles to the new region. DPR size is changed to the new value. When it does this, there should not be any DMA cycles going to DRAM to the new region.

If there were cycles from a rogue device to the new region, then those could use the previous decode until the new decode can ensure PV. No flushing of cycles is required. On a clock by clock basis proper decode with the previous or new decode needs to be ensured.

All upstream cycles from 0 to (TSEG_BASE – 1 – DPR size), and not in the legacy holes (VGA), are decoded to dram.

2.2.2.5 Pre-allocated Memory

Voids of physical addresses that are not accessible as general system memory and reside within system memory address range (< TOLUD) are created for SMM-mode, legacy VGA graphics compatibility, and graphics GTT stolen memory. It is the responsibility of BIOS to properly initialize these regions.

2.2.2.6 Graphics Stolen Spaces

2.2.2.6.1 GTT Stolen Space (GSM)

GSM is allocated to store the GFX translation table entries, depending on VT-d support it may be divided into 2 sections.

2.2.2.6.2 Global GTT Stolen Space (GGSM)

GGSM always exists regardless of VT-d as long as internal GFX is enabled. This space is allocated to store accesses as page table entries are getting updated through virtual GTTMMADR range. Hardware is responsible to map PTEs into this physical space.

Direct accesses to GGSM is not allowed, only hardware translations and fetches can be directed to GGSM.



2.2.2.6.3 Shadow GTT Stolen Space (SGSM)

Shadow GSM will be only used once internal GFX and VT-d translations are enabled. The purpose of shadow GSM is to provide a physical space to hardware, where VT-d translation for PTE updates can be made on the fly and re-written back into physical memory.

2.2.2.7 Intel® Management Engine (Intel® ME) UMA

ME (the iAMT Manageability Engine) can be allocated UMA memory. ME memory is “stolen” from the top of the host address map. The ME stolen memory base is calculated by subtracting the amount of memory stolen by the Manageability Engine from TOM.

Only ME can access this space; it is not accessible by or coherent with any processor side accesses.

2.2.2.8 PCI Memory Address Range (TOLUD – 4 GB)

This address range, from the top of low usable DRAM (TOLUD) to 4 GB is normally mapped to the DMI Interface.

Device 0 exceptions are:

1. Addresses decoded to the egress port registers (PXPEPBAR)
2. Addresses decoded to the memory mapped range for internal processor registers (GMCHBAR)
3. Addresses decoded to the registers associated with the processor/PCH Serial Interconnect (DMI) register memory range. (DMIBAR)

For each PCI Express port, there are two exceptions to this rule:

1. Addresses decoded to the PCI Express Memory Window defined by the MBASE1, MLIMIT1, registers are mapped to PCI Express.
2. Addresses decoded to the PCI Express prefetchable Memory Window defined by the PMBASE1, PMLIMIT1, registers are mapped to PCI Express.

In integrated graphics configurations, there are exceptions to this rule:

1. Addresses decode to the internal graphics translation window (GMADR)
2. Addresses decode to the Internal graphics translation table or IGD registers. (GTTMMADR)

In a VT enable configuration, there are exceptions to this rule:

1. Addresses decoded to the memory mapped window to DMI VC1 VT remap engine registers (DMIVC1BAR)
2. Addresses decoded to the memory mapped window to Graphics VT remap engine registers (GFXVTBAR)
3. Addresses decoded to the memory mapped window to PEG/DMI/ME VC0 VT remap engine registers (VTDPVCOBAR)
4. TCm accesses (to ME stolen memory) from PCH do not go through VT remap engines.

Some of the MMIO Bars may be mapped to this range or to the range above TOLUD.



There are sub-ranges within the PCI Memory address range defined as APIC Configuration Space, MSI Interrupt Space, and High BIOS Address Range. The exceptions listed above for internal graphics and the PCI Express ports **MUST NOT overlap with these ranges.**

Figure 2-4. PCI Memory Address Range

FFFF_FFFFh	High BIOS	4 GB
FFE0_0000h	DMI Interface (subtractive decode)	4 GB – 2 MB
FEF0_0000h	MSI Interrupts	4 GB – 17 MB
FEE0_0000h	DMI Interface (subtractive decode)	4 GB – 18 MB
FED0_0000h	Local (CPU) APIC	4 GB – 19 MB
FEC8_0000h	I/O APIC	
FEC0_0000h	DMI Interface (subtractive decode)	4 GB – 20 MB
F000_0000h	PCI Express Configuration Space	Possible address range/size (not ensured)
E000_0000h	DMI Interface (subtractive decode)	4 GB – 512 MB
		<i>BARs, Internal Graphics ranges, PCI Express Port, CHAPADR could be here.</i>
		TOLUD



2.2.2.9 APIC Configuration Space (FECO_0000h–FECF_FFFFh)

This range is reserved for APIC configuration space. The I/O APIC(s) usually reside in the PCH portion of the chipset, but may also exist as stand-alone components like PXH.

The IOAPIC spaces are used to communicate with IOAPIC interrupt controllers that may be populated in the system. Since it is difficult to relocate an interrupt controller using plug-and-play software, fixed address decode regions have been allocated for them. Processor accesses to the default IOAPIC region (FECO_0000h to FEC7_FFFFh) are always forwarded to DMI.

The processor optionally supports additional I/O APICs behind the PCI Express “Graphics” port. When enabled using the PCI Express Configuration register (Device 1, Offset 200h and Device 6, Offset 200h), the PCI Express port(s) will positively decode a subset of the APIC configuration space. Specifically,

- Device 6 can be enabled to claim FEC8_0000h thru FECB_FFFFh.
- Device 1 can be enabled to claim FECC_0000h thru FECF_FFFFh.

Memory requests to this range would then be forwarded to the PCI Express port. This mode is intended for the entry Workstation SKU of the processor, and would be disabled in typical Desktop systems. When disabled, any access within entire APIC Configuration space (FECO_0000h to FECF_FFFFh) is forwarded to DMI.

2.2.2.9.1 MSI Interrupt Memory Space (FEE0_0000 – FEEF_FFFF)

Any PCI Express or DMI device may issue a Memory Write to 0FEEx_xxxxh. This Memory Write cycle does not go to DRAM. The processor will forward this Memory Write along with the data to the processor as a QPI Interrupt Message Transaction.

This interrupt message will be delivered to the processor as an IntPhysical or IntLogical message.

2.2.2.10 High BIOS Area

For security reasons, the processor will now positively decode this range to DMI. This positive decode will ensure any overlapping ranges will be ignored.

The top 2 MB (FEE0_0000h – FFFF_FFFFh) of the PCI Memory Address Range is reserved for System BIOS (High BIOS), extended BIOS for PCI devices, and the A20 alias of the system BIOS. The processor begins execution from the High BIOS after reset. This region is positively decoded to DMI Interface so that the upper subset of this region aliases to 16 MB – 256 KB range. The actual address space required for the BIOS is less than 2 MB but the minimum processor MTRR range for this region is 2 MB so that full 2 MB must be considered.



2.2.3 Main Memory Address Space (4 GB to TOUUD)

The processor will support 36 bit addressing. The maximum main memory size supported is 16 GB total DRAM memory. A hole between TOLUD and 4 GB occurs when main memory size approaches 4 GB or larger. As a result, TOM, and TOUUD registers and REMAPBASE/REMAPLIMIT registers become relevant.

The remap configuration registers exist to remap lost main memory space. The greater than 32 bit remap handling will be handled similar to other processors.

Upstream read and write accesses above 36-bit addressing will be treated as invalid cycles by PEG and DMI.

Top of Memory (TOM)

The “Top of Memory” (TOM) register reflects the total amount of populated physical memory. This is NOT necessarily the highest main memory address (holes may exist in main memory address map due to addresses allocated for memory mapped I/O above TOM).

The Manageability Engine's (ME) stolen size register reflects the total amount of physical memory stolen by the Manageability Engine. The ME stolen memory is located at the top of physical memory. The ME stolen memory base is calculated by subtracting the amount of memory stolen by the Manageability Engine from TOM.

Top of Upper Usable DRAM (TOUUD)

The Top of Upper Usable Dram (TOUUD) register reflects the total amount of addressable DRAM. If remap is disabled, TOUUD will reflect TOM minus Manageability Engine's stolen size. If remap is enabled, then it will reflect the remap limit.

Note: When there is more than 4 GB of DRAM and reclaim is enabled, the reclaim base will be the same as TOM minus ME stolen memory size to the nearest 64 MB alignment (shown in case 2 below).

Top of Low Usable DRAM (TOLUD)

TOLUD register is restricted to 4 GB memory (A[31:20]), but the processor can support up to 16 GB, limited by DRAM pins. For physical memory greater than 4 GB, the TOUUD register helps identify the address range in between the 4 GB boundary and the top of physical memory. This identifies memory that can be directly accessed (including remap address calculation) which is useful for memory access indication and early path indication. When remap is enabled, TOLUD must be 64 MB aligned, but when remap is disabled, TOLUD can be 1 MB aligned.

TSEG_BASE

The “TSEG_BASE” register reflects the total amount of low addressable DRAM, below TOLUD. BIOS will calculate and program this register, so the processor has knowledge of where (TOLUD) – (Gfx stolen) – (Gfx GTT stolen) – (TSEG) is located. I/O blocks use this minus DPR for upstream DRAM decode.



2.2.3.1 Programming Model

The memory boundaries of interest are:

- Bottom of Logical Address Remap Window defined by the REMAPBASE register, which is calculated and loaded by BIOS.
- Top of Logical Address Remap Window defined by the REMAPLIMIT register, which is calculated and loaded by BIOS.
- Bottom of Physical Remap Memory defined by the existing TOLUD register.
- Top of Physical Remap Memory, which is implicitly defined by either 4 GB or TOM minus Manageability Engine stolen size.

Mapping steps:

1. Determine TOM
2. Determine TOM minus ME stolen size
3. Determine MMIO allocation
4. Determine TOLUD
5. Determine GFX stolen base
6. Determine GFX GTT stolen base
7. Determine TSEG base
8. Determine remap base/limit
9. Determine TOUUD

The following diagrams show the three possible general cases of remapping.

Case 1: Less than 4 GB of Physical Memory, no remap

Case 2: Greater than 4 GB of Physical Memory

Case 3: 4 GB or Less of Physical Memory



2.2.3.1.1 Case 1 — Less than 4 GB of Physical Memory (no remap)

Figure 2-5. Case 1 — Less than 4 GB of Physical Memory (no remap)

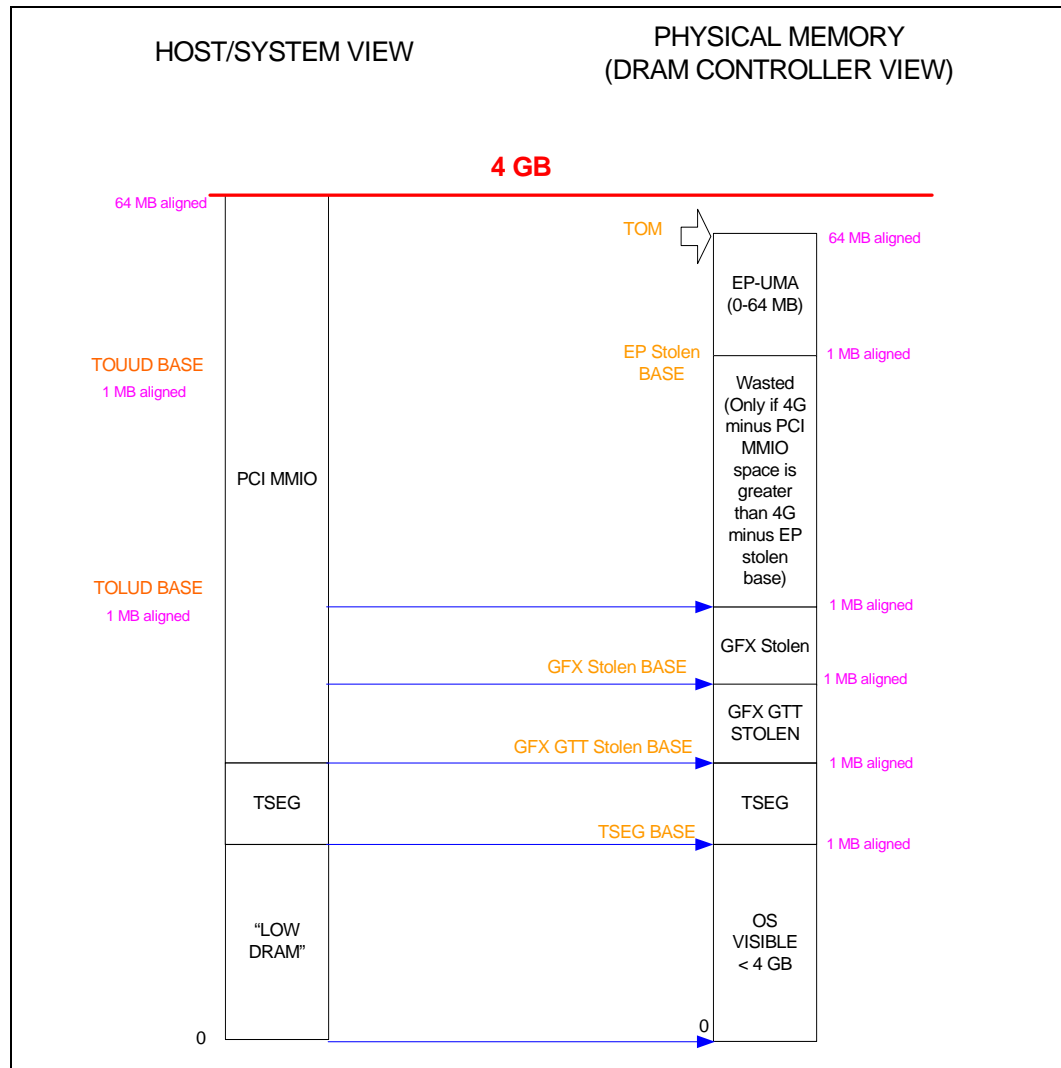

- Populated Physical Memory = 2 GB
- Address Space allocated to memory mapped I/O = 1 GB
- Remapped Physical Memory = 0 GB
- TOM – 020h (2 GB)
- ME stolen size – 00001b (1 MB)
- TOUUD – 07FFh (2 GB minus 1 MB) (1 MB aligned)
- TOLUD – 01F00h (2 GB minus 64 MB) (63 MB wasted because MMIO space required is greater than 4G to EP stolen base.)
- REMAPBASE – 3FFh (64 GB – 1 boundary, default)
- REMAPLIMIT – 000h (0GB boundary, default)

2.2.3.1.2 Case 2 — Greater than 4 GB of Physical Memory

Note: Internal graphics is not supported on the Intel Xeon processor L3406.

Figure 2-6. Case 2 — Greater than 4 GB of Physical Memory

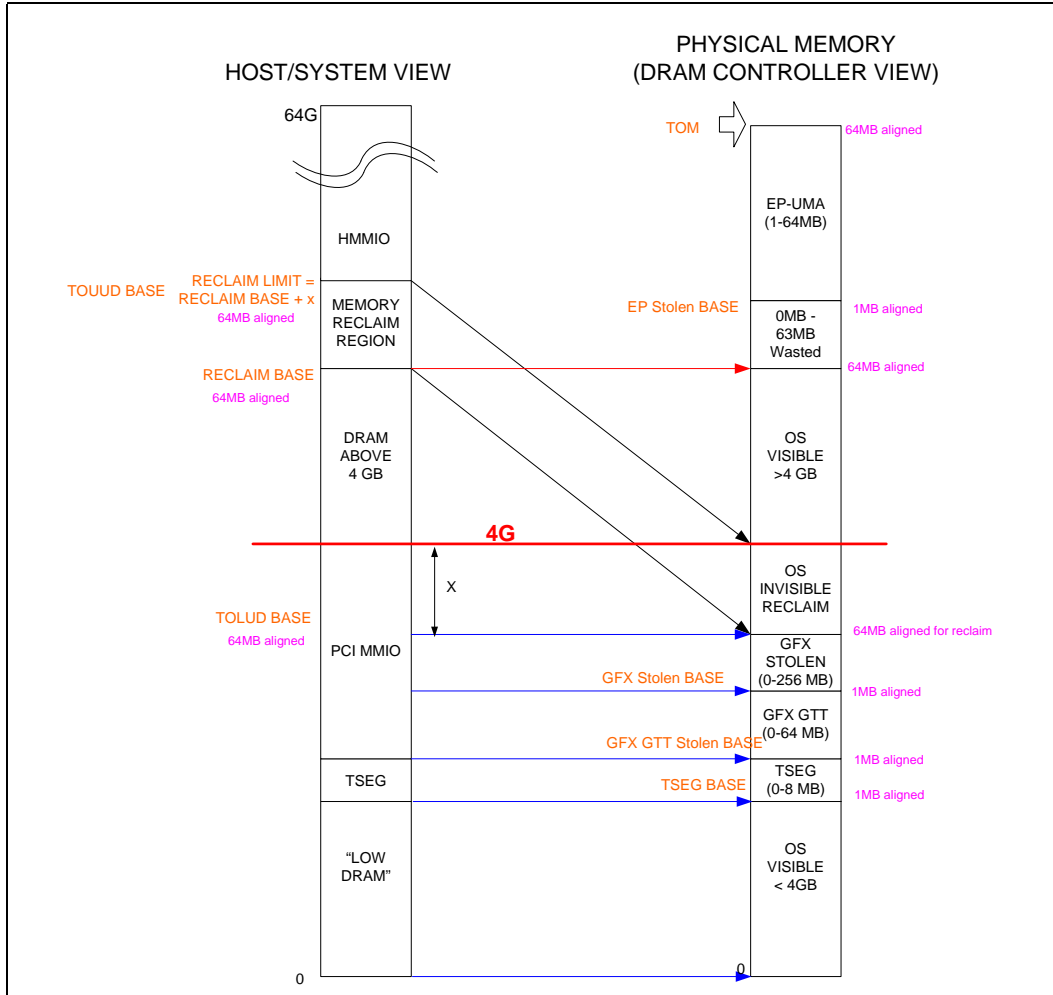

In this case the amount of memory remapped is the range between TOLUD and 4 GB. This physical memory will be mapped to the logical address range defined between the REMAPBASE and the REMAPLIMIT registers.

Example: 5 GB Physical Memory, with 1 GB allocated to Memory Mapped I/O

- Populated Physical Memory = 5 GB
- Address Space allocated to memory mapped I/O = 1 GB
- Remapped Physical Memory = 1 GB
- TOM – 050h (5 GB)
- ME stolen size – 00000b (0 MB)
- TOUUD – 1800h (6 GB) (1 MB aligned)
- TOLUD – 06000h (3 GB) (64 MB aligned because remap is enabled and the remap register has 64 MB granularity)
- REMAPBASE – 050h (5 GB)
- REMAPLIMIT – 05Fh (6 GB – 1 boundary)

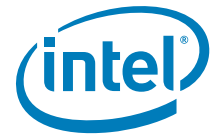

2.2.3.1.3 Case 3 — 4 GB or less of Physical Memory

Note: Internal graphics is not supported on the Intel Xeon processor L3406.

Figure 2-7. 4 GB or Less of Physical Memory

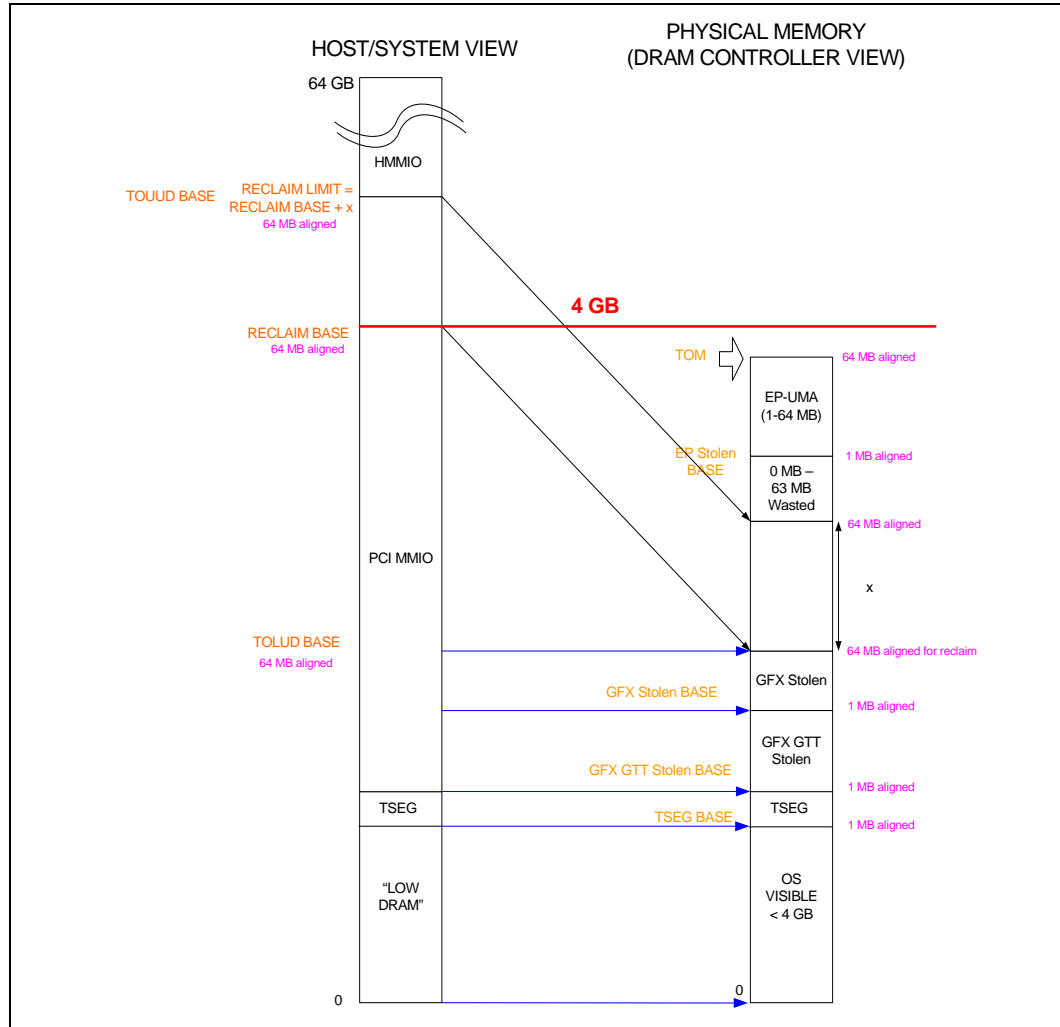

In this case the amount of memory remapped is the range between TOLUD and TOM minus the ME stolen memory. This physical memory will be mapped to the logical address range defined between the REMAPBASE and the REMAPLIMIT registers.

Example: 3 GB Physical Memory, with 2 GB allocated to Memory Mapped I/O

- Populated Physical Memory = 3 GB
- Address Space allocated to memory mapped I/O = 2 GB
- Remapped Physical Memory = 1 GB
- TOM – 030h (3 GB)
- ME stolen size – 00000b (0 MB)
- TOUUD – 1400h (5GB) (1 MB aligned)
- TOLUD – 02000h (2 GB) (64 MB aligned because remap is enabled and the remap register has 64 MB granularity)
- REMAPBASE – 040h (4 GB)
- REMAPLIMIT – 04Fh (5 GB – 1 boundary)

2.2.3.1.4 Case 4 — Greater than 4 GB of Physical Memory, Remap

Note: Internal graphics is not supported on the Intel Xeon processor L3406.

Figure 2-8. Greater than 4 GB, Remap Enabled

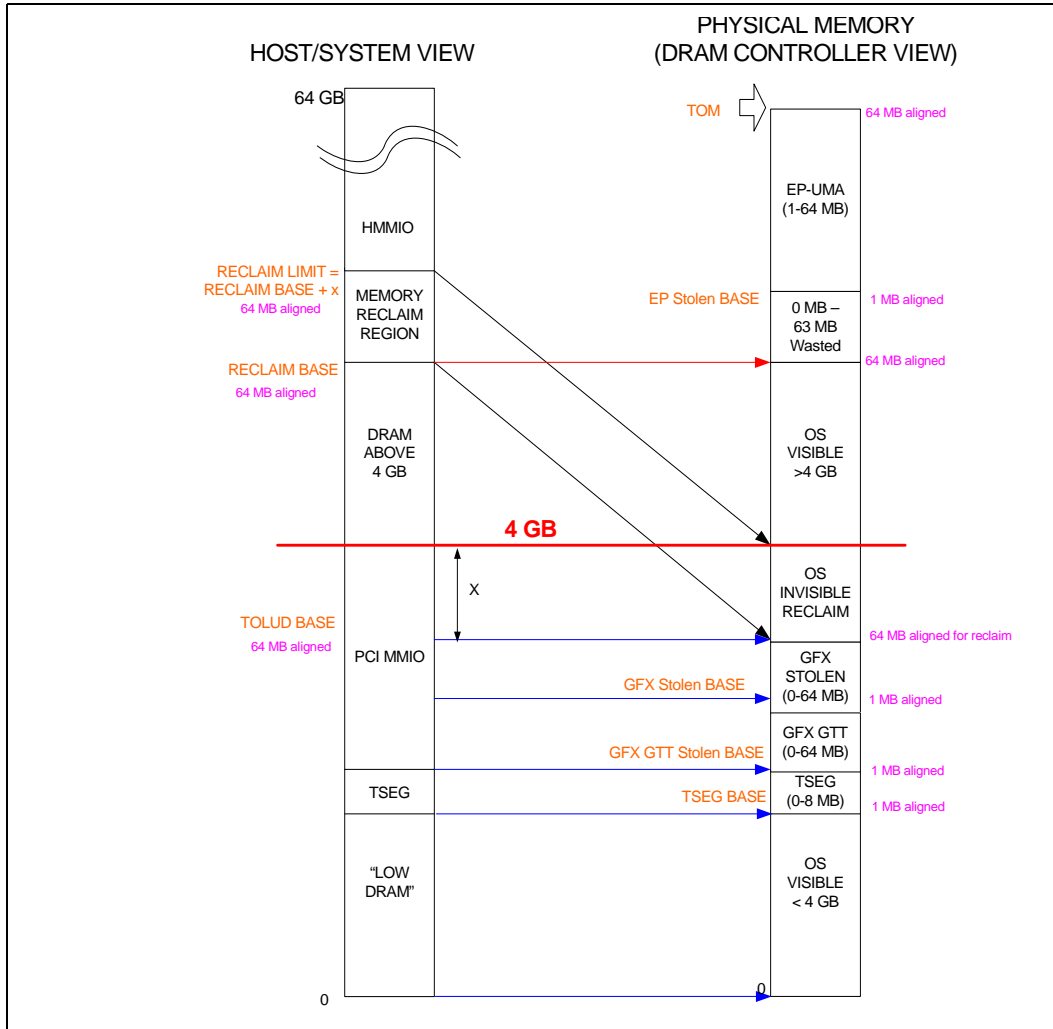

In this case the amount of memory remapped is the range between TOLUD and 4 GB. This physical memory will be mapped to the logical address range defined between the REMAPBASE and the REMAPLIMIT registers.

Example: 5 GB Physical Memory, with 1 GB allocated to Memory Mapped I/O

- Populated Physical Memory = 5 GB
- Address Space allocated to memory mapped I/O = 1 GB
- Remapped Physical Memory = 1 GB
- TOM – 050h (5 GB)
- ME stolen size – 00000b (0 MB)
- TOUUD – 17FFh (6 GB – 1 MB) (1 MB aligned)
- TOLUD – 06000h (3 GB) (64 MB aligned because remap is enabled and the remap register has 64 MB granularity)
- REMAPBASE – 050h (5GB)
- REMAPLIMIT – 05Fh (6 GB – 1 boundary)



2.2.4 PCI Express* Configuration Address Space

PCIEXBAR has moved to the processor. The processor now detects memory accesses targeting PCIEXBAR and the processor converts that access to QPI configuration accesses. BIOS must assign this address range such that it will not conflict with any other address ranges.

2.2.5 PCI Express* Graphics Attach (PEG)

The processor can be programmed to direct memory accesses to a PCI Express interface. When addresses are within either of two ranges specified using registers in each PEG(s) configuration space:

- The first range is controlled using the Memory Base Register (MBASE) and Memory Limit Register (MLIMIT) registers.
- The second range is controlled using the Pre-fetchable Memory Base (PMBASE) and Pre-fetchable Memory Limit (PMLIMIT) registers.

Conceptually, address decoding for each range follows the same basic concept. The top 12 bits of the respective Memory Base and Memory Limit registers correspond to address bits A[31:20] of a memory address. For the purpose of address decoding, the processor assumes that address bits A[19:0] of the memory base are zero and that address bits A[19:0] of the memory limit address are F_FFFFh. This forces each memory address range to be aligned to a 1MB boundary and to have a size granularity of 1 MB.

The processor positively decodes memory accesses to PCI Express memory address space as defined by the following equations:

$$\text{Memory_Base_Address} \leq \text{Address} \leq \text{Memory_Limit_Address}$$

$$\text{Prefetchable_Memory_Base_Address} \leq \text{Address} \leq \text{Prefetchable_Memory_Limit_Address}$$

The window size is programmed by the plug-and-play configuration software. The window size depends on the size of memory claimed by the PCI Express device. Normally, these ranges will reside above the Top-of-Low Usable-DRAM and below High BIOS and APIC address ranges. They MUST reside above the top of low memory (TOLUD) if they reside below 4 GB and MUST reside above top of upper memory (TOUUD) if they reside above 4 GB or they will steal physical DRAM memory space.

It is essential to support a separate Pre-fetchable range in order to apply USWC attribute (from the processor point of view) to that range. The USWC attribute is used by the processor for write combining.

Note that the processor memory range registers described above are used to allocate memory address space for any PCI Express devices sitting on PCI Express that require such a window.

The PCICMD1 register can override the routing of memory accesses to PCI Express. In other words, the memory access enable bit must be set to enable the memory base/limit and pre-fetchable base/limit windows.

The upper PMUBASE/PMULIMIT registers have been implemented for PCI Express Specification compliance. The processor locates MMIO space above 4 GB using these registers.



2.2.6 Graphics Memory Address Ranges

The processor can be programmed to direct memory accesses to IGD when addresses are within any of five ranges specified using registers in the processor Device 2 configuration space.

1. The Graphics Memory Aperture Base Register (GMADR) is used to access graphics memory allocated using the graphics translation table.
2. The Graphics Translation Table Base Register (GTTADR) is used to access the translation table and graphics control registers.
3. This is part of GTTMMADR register.

These ranges can reside above the Top-of-Low-DRAM and below High BIOS and APIC address ranges. They MUST reside above the top of memory (TOLUD) and below 4 GB so they do not steal any physical DRAM memory space.

Alternatively, these ranges can reside above 4 GB, similar to other BARs which are larger than 32 bits in size.

GMADR is a Prefetchable range in order to apply USWC attribute (from the processor point of view) to that range. The USWC attribute is used by the processor for write combining.

2.2.6.1 IOBAR Mapped Access to Device 2 MMIO Space

Device 2, integrated graphics device, contains an IOBAR register. If Device 2 is enabled, then IGD registers or the GTT table can be accessed using this IOBAR. The IOBAR is composed of an index register and a data register.

MMIO_Index — MMIO_INDEX is a 32 bit register. An IO write to this port loads the offset of the MMIO register or offset into the GTT that needs to be accessed. An IO Read returns the current value of this register. See IOBAR rules for detailed information.

MMIO_Data — MMIO_DATA is a 32 bit register. An IO write to this port is re-directed to the MMIO register pointed to by the MMIO-index register. An IO read to this port is re-directed to the MMIO register pointed to by the MMIO-index register. See IOBAR rules for detailed information.

The result of accesses through IOBAR can be:

- Accesses directed to the GTT table. (that is, route to DRAM)
- Accesses to internal graphics registers with the processor (that is, route to internal configuration bus)
- Accesses to internal graphics display registers now located within the PCH. (that is, route to DMI).

Note: GTT table space writes (GTTADR) are supported through this mapping mechanism.

This mechanism to access internal graphics MMIO registers must not be used to access VGA IO registers which are mapped through the MMIO space. VGA registers must be accessed directly through the dedicated VGA I/O ports.



2.2.7 System Management Mode (SMM)

The processor handles all SMM mode transaction routing. The processor has no direct knowledge of SMM mode. The processor will never allow I/O devices access to CSEG/TSEG/HSEG ranges.

DMI Interface and PCI Express masters are not allowed to access the SMM space.

Table 2-2. SMM Regions

SMM Space Enabled	Transaction Address Space	DRAM Space (DRAM)
Compatible (C)	000A_0000h to 000B_FFFFh	000A_0000h to 000B_FFFFh
TSEG (T)	(TOLUD-STOLEN-TSEG) to TOLUD-STOLEN	(TOLUD-STOLEN-TSEG) to TOLUD-STOLEN

2.2.8 SMM and VGA Access through GTT TLB

Accesses through GTT TLB address translation SMM DRAM space are not allowed. Writes will be routed to Memory address 000C_0000h with byte enables de-asserted and reads will be routed to Memory address 000C_0000h. If a GTT TLB translated address hits SMM DRAM space, an error is recorded in the PGTBL_ER register.

PCI Express and DMI Interface originated accesses are never allowed to access SMM space directly or through the GTT TLB address translation. If a GTT TLB translated address hits enabled SMM DRAM space, an error is recorded in the PGTBL_ER register.

PCI Express* and DMI Interface write accesses through GMADR range will not be snooped. Only PCI Express* and DMI accesses to GMADR linear range (defined using fence registers) are supported. PCI Express and DMI Interface tileY and tileX writes to GMADR are not supported. If, when translated, the resulting physical address is to enabled SMM DRAM space, the request will be remapped to address 000C_0000h with de-asserted byte enables.

PCI Express and DMI Interface read accesses to the GMADR range are not supported; therefore, will have no address translation concerns. PCI Express and DMI Interface reads to GMADR will be remapped to address 000C_0000h. The read will complete with UR (unsupported request) completion status.

GTT fetches are always decoded (at fetch time) to ensure that they are not in SMM (actually, anything above base of TSEG or 640 KB-1 MB). Thus, they will be invalid and go to address 000C_0000h, but that is not specific to PCI Express or DMI; it applies to the processor or internal graphics engines.

2.2.9 I/O Address Space

The processor generates either DMI Interface or PCI Express* bus cycles for all processor I/O accesses that it does not claim. The processor no longer contains the two internal registers in the processor I/O space, Configuration Address Register (CONFIG_ADDRESS) and the Configuration Data Register (CONFIG_DATA). The processor now handles accesses to these registers, which ultimately generate a QPI configuration access.

The processor allows 64K+3 bytes to be addressed within the I/O space. The processor propagates the processor I/O address without any translation on to the destination bus and, therefore, provides addressability for 64K+3 byte locations. Note that the upper 3



locations can be accessed only during I/O address wrap-around when address bit 16 is asserted. Address bit 16 is asserted on the processor bus whenever an I/O access is made to 4 bytes from address 0FFFDh, 0FFFEh, or 0FFFFh. Address bit 16 is also asserted when an I/O access is made to 2 bytes from address 0FFFFh.

A set of I/O accesses are consumed by the internal graphics device if it is enabled. The mechanisms for internal graphics IO decode and the associated control is explained later.

The I/O accesses are forwarded normally to the DMI Interface bus unless they fall within the PCI Express I/O address range as defined by the mechanisms explained below. I/O writes are NOT posted. Memory writes to PCH or PCI Express are posted. The PCI Express devices have a register that can disable the routing of I/O cycles to the PCI Express device.

The processor responds to I/O cycles initiated on PCI Express or DMI with an UR status. Upstream I/O cycles and configuration cycles should never occur. If one does occur, the request will route as a read to Memory address 000C_0000h so a completion is naturally generated (whether the original request was a read or write). The transaction will complete with an UR completion status.

QPI I/O reads that lie within 8-byte boundaries but cross 4-byte boundaries are issued from the processor as 1 transaction. The processor will break this into 2 separate transactions. I/O writes that lie within 8-byte boundaries but cross 4-byte boundaries will be split into 2 transactions by the processor.

2.2.9.1 PCI Express* I/O Address Mapping

The processor can be programmed to direct non-memory (I/O) accesses to the PCI Express bus interface when processor initiated I/O cycle addresses are within the PCI Express I/O address range. This range is controlled using the I/O Base Address (IOBASE) and I/O Limit Address (IOLIMIT) registers in processor Device 1 or Device 6 (if a 2nd PEG port is enabled) configuration space.

Address decoding for this range is based on the following concept. The top 4 bits of the respective I/O Base and I/O Limit registers correspond to address bits A[15:12] of an I/O address. For the purpose of address decoding, the processor assumes that lower 12 address bits A[11:0] of the I/O base are zero and that address bits A[11:0] of the I/O limit address are FFFh. This forces the I/O address range alignment to 4 KB boundary and produces a size granularity of 4 KB.

The processor positively decodes I/O accesses to PCI Express I/O address space as defined by the following equation:

$$I/O_Base_Address \leq \text{processor I/O Cycle Address} \leq I/O_Limit_Address$$

The effective size of the range is programmed by the plug-and-play configuration software and it depends on the size of I/O space claimed by the PCI Express device.

The processor also forwards accesses to the Legacy VGA I/O ranges according to the settings in the Device 1 configuration registers BCTRL (VGA Enable) and PCICMD1 (IOAE1), unless a second adapter (monochrome) is present on the DMI Interface/PCI (or ISA). The presence of a second graphics adapter is determined by the MDAP configuration bit. When MDAP is set, the processor will decode legacy monochrome IO ranges and forward them to the DMI Interface. The IO ranges decoded for the monochrome adapter are 3B4h, 3B5h, 3B8h, 3B9h, 3Bah and 3BFh.



Note that the processor Device 1 I/O address range registers defined above are used for all I/O space allocation for any devices requiring such a window on PCI-Express.

The PCICMD1 register can disable the routing of I/O cycles to PCI-Express.

2.3 Configuration Process and Registers

2.3.1 Platform Configuration Structure

The DMI physically connects the processor and the Intel PCH; so, from a configuration standpoint, the DMI is logically PCI Bus 0. As a result, all devices internal to the processor and the Intel PCH appear to be on PCI Bus 0.

Note: The PCH internal LAN controller does not appear on Bus 0 — it appears on the external PCI bus (whose number is configurable).

The system's primary PCI expansion bus is physically attached to the PCH and, from a configuration perspective, appears to be a hierarchical PCI bus behind a PCI-to-PCI bridge and therefore has a programmable PCI Bus number. The PCI Express Graphics Attach appears to system software to be a real PCI bus behind a PCI-to-PCI bridge that is a device resident on PCI Bus 0.

Note: A physical PCI bus 0 does not exist. DMI and the internal devices in the processor and PCH logically constitute PCI Bus 0 to configuration software.

The processor contains the following PCI devices within a single physical component. The configuration registers for these devices are mapped as devices residing on PCI Bus 0.

- **Device 0** — Host Bridge/DRAM Controller. Logically this appears as a PCI device residing on PCI Bus 0. Device 0 contains the standard PCI header registers, PCI Express base address register, DRAM control (including thermal/throttling control), configuration for the DMI, and other processor specific registers.
- **Device 1** — Host-PCI Express Bridge. Logically this appears as a “virtual” PCI-to-PCI bridge residing on PCI Bus 0 and is compliant with PCI Express Base Specification. Device 1 contains the standard PCI-to-PCI bridge registers and the standard PCI Express/PCI configuration registers (including the PCI Express memory address mapping).
- **Device 2** — Internal Graphics Device. Logically, this appears as an APCI device residing on PCI Bus 0. Physically, Device 2 contains the configurations registers for 3D, 2D, and display functions.
- **Device 6** — Secondary Host to PCI Express Bridge. (Not supported on all SKUs)



Table 2-3. Device Number Assignment for Internal Processor Devices

Processor Function	Device Number
Host Bridge/DRAM Controller	Device 0
Host-to-PCI Express* Bridge (virtual P2P)	Device 1
Internal Graphics Device	Device 2
Secondary Host-to-PCI Express Bridge (Device 6 is not supported on all SKUs.)	Device 6

2.4 Configuration Mechanisms

The GMCH is the originator of configuration cycles. Internal to the GMCH transactions received through both configuration mechanisms are translated to the same format.

2.4.1 Standard PCI Configuration Mechanism

The following is the mechanism for translating GMCH I/O bus cycles to configuration cycles.

The PCI specification defines a slot based "configuration space" that allows each device to contain up to eight functions with each function containing up to 256, 8-bit configuration registers. The PCI specification defines two bus cycles to access the PCI configuration space: Configuration Read and Configuration Write. Memory and I/O spaces are supported directly by the GMCH. Configuration space is supported by a mapping mechanism implemented within the GMCH.

The configuration access mechanism makes use of the CONFIG_ADDRESS Register (at I/O address 0CF8h through 0CFBh) and CONFIG_DATA Register (at I/O address 0CFCh through 0CFFh). To reference a configuration register, a DW I/O write cycle is used to place a value into CONFIG_ADDRESS that specifies the PCI bus, the device on that bus, the function within the device and a specific configuration register of the device function being accessed. CONFIG_ADDRESS[31] must be 1 to enable a configuration cycle. CONFIG_DATA then becomes a window into the four bytes of configuration space specified by the contents of CONFIG_ADDRESS. Any read or write to CONFIG_DATA will result in the GMCH translating the CONFIG_ADDRESS into the appropriate configuration cycle.

The GMCH is responsible for translating and routing the GMCH's I/O accesses to the CONFIG_ADDRESS and CONFIG_DATA registers to internal GMCH configuration registers, DMI or PCI Express.



2.4.2 PCI Express* Enhanced Configuration Mechanism

PCI Express extends the configuration space to 4096 bytes per device/function as compared to 256 bytes allowed by the latest *PCI Local Bus Specification*. PCI Express configuration space is divided into a PCI 3.0 compatible region, which consists of the first 256B of a logical device's configuration space and a PCI Express extended region which consists of the remaining configuration space.

The PCI compatible region can be accessed using either the Standard PCI Configuration Mechanism or using the PCI Express Enhanced Configuration Mechanism described in this section. The extended configuration registers may only be accessed using the PCI Express Enhanced Configuration Mechanism. To maintain compatibility with PCI configuration addressing mechanisms, system software must access the extended configuration space using 32-bit operations (32-bit aligned) only. These 32-bit operations include byte enables allowing only appropriate bytes within the DWord to be accessed. Locked transactions to the PCI Express memory mapped configuration address space are not supported. All changes made using either access mechanism are equivalent.

The PCI Express Enhanced Configuration Mechanism utilizes a flat memory-mapped address space to access device configuration registers. This address space is reported by the system firmware to the operating system. There is a register, PCIEXBAR, that defines the base address for the block of addresses below 4 GB for the configuration space associated with busses, devices and functions that are potentially a part of the PCI Express root complex hierarchy. In the PCIEXBAR register there are controls to limit the size of this reserved memory mapped space. 256 MB is the amount of address space required to reserve space for every bus, device, and function that could possibly exist. Options for 128 MB and 64 MB exist in order to free up those addresses for other uses. In these cases the number of busses and all of their associated devices and functions are limited to 128 or 64 busses, respectively.

The PCI Express Configuration Transaction Header includes an additional 4 bits (ExtendedRegisterAddress[3:0]) between the Function Number and Register Address fields to provide indexing into the 4 KB of configuration space allocated to each potential device. For PCI Compatible Configuration Requests, the Extended Register Address field must be all zeros.

Figure 2-9. Memory Map to PCI Express Device Configuration Space

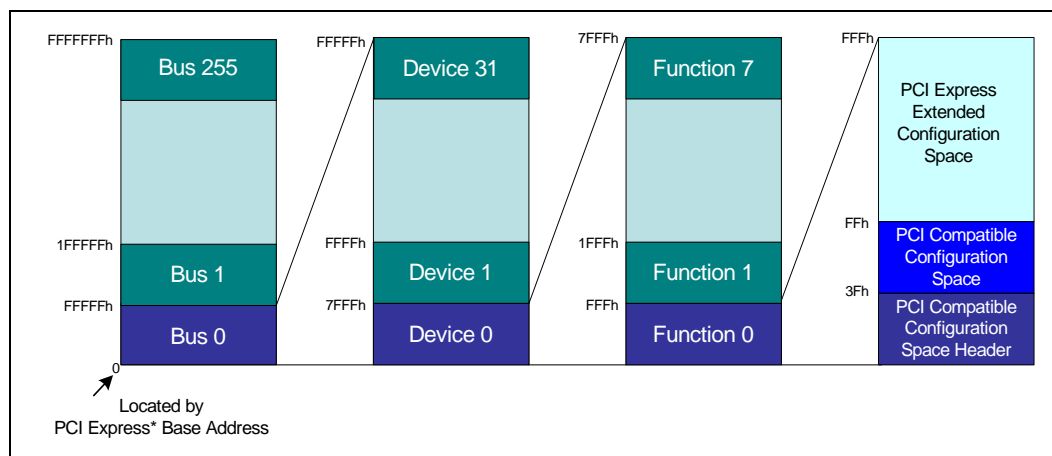



Just the same as with PCI devices, each device is selected based on decoded address information that is provided as a part of the address portion of Configuration Request packets. A PCI Express device will decode all address information fields (bus, device, function and extended address numbers) to provide access to the correct register.

To access this space (step 1 is done only once by BIOS),

First determine the maximum bus number using the following algorithm.

1. Write to I/O address 0CF8h with value 80FF_1050h.
2. Read from I/O address 0CFCh. If the value is FFFF_FFFFh (master abort), then go to step 3, otherwise max bus number is FFh.
3. Write to I/O address 0CF8h with value 807F_1050h.
4. Read from I/O address 0CFCh. If the value is FFFF_FFFFh (master abort), then maximum bus number is 3Fh; otherwise, maximum bus number is 7Fh.

Write to the PCIEXBAR register at the maximum bus number, device 2, function 0, offset 50h. Write 1 to bit 0 of the register to enable the enhanced configuration mechanism. Allocate either 256, 128, or 64 busses to PCI Express by writing "000", "111", or "110" respectively to bits 3:1. Pick a naturally aligned base address for mapping the configuration space onto memory space using 1 MB per bus number and write that base address into Bits 39:20.

Calculate the host address of the register you wish to set using (PCI Express base + (bus number * 1 MB) + (device number * 32 KB) + (function number * 4 KB) + (1 B * offset within the function) = host address)

Use a memory write or memory read cycle to the calculated host address to write or read that register.

2.4.3 Routing Configuration Accesses

The processor supports two PCI related interfaces — DMI and PCI Express. The processor is responsible for routing PCI and PCI Express configuration cycles to the appropriate device that is an integrated part of the processor or to one of these two interfaces. Configuration cycles to the PCH internal devices and Primary PCI (including downstream devices) are routed to the PCH using DMI. Configuration cycles to both the PCI Express Graphics PCI compatibility configuration space and the PCI Express Graphics extended configuration space are routed to the PCI Express Graphics port device or associated link.

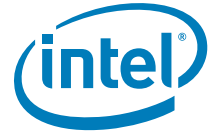
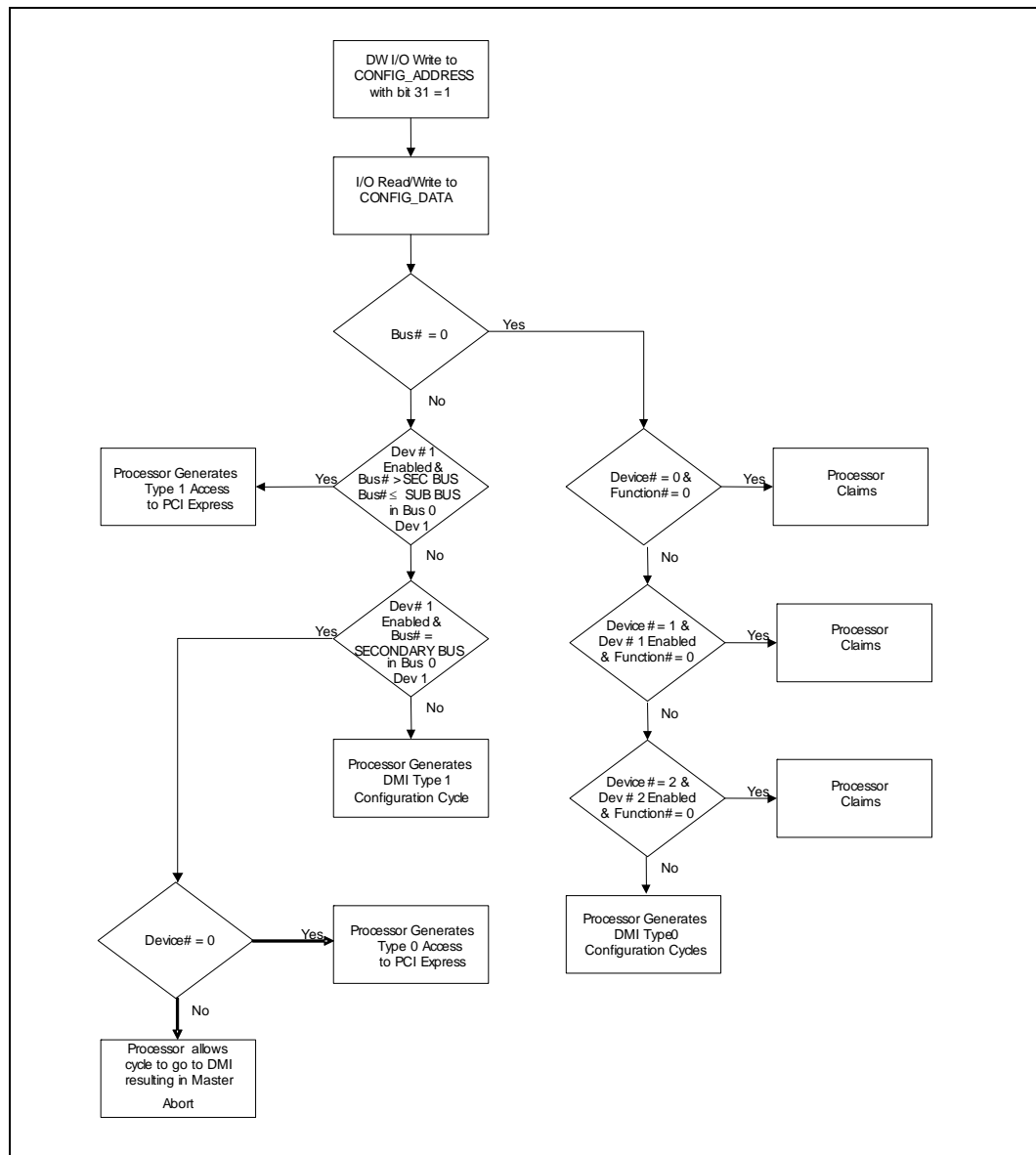

Figure 2-10. Processor Configuration Cycle Flow Chart



2.4.4 Internal Device Configuration Accesses

The processor decodes the Bus Number (Bits 23:16) and the Device Number fields of the CONFIG_ADDRESS register. If the Bus Number field of CONFIG_ADDRESS is 0, the configuration cycle is targeting a PCI Bus 0 device.

If the targeted PCI Bus 0 device exists in the processor and is not disabled, the configuration cycle is claimed by the appropriate device.



2.4.5 Bridge Related Configuration Accesses

Configuration accesses on PCI Express or DMI are PCI Express Configuration TLPs.

- Bus Number [7:0] is Header Byte 8 [7:0]
- Device Number [4:0] is Header Byte 9 [7:3]
- Function Number [2:0] is Header Byte 9 [2:0]

And special fields for this type of TLP:

- Extended Register Number [3:0] is Header Byte 10 [3:0]
- Register Number [5:0] is Header Byte 11 [7:2]

See the *PCI Express Base Specification* and the *PCI Local Bus Specification Revision 3.0* for more information on both the PCI 3.0-compatible and PCI Express Enhanced Configuration Mechanism and transaction rules.

2.4.5.1 PCI Express* Configuration Accesses

When the Bus Number of a type 1 Standard PCI Configuration cycle or PCI Express Enhanced Configuration access matches the Device 1 Secondary Bus Number, a PCI Express Type 0 Configuration TLP is generated on the PCI Express link targeting the device directly on the opposite side of the link. This should be Device 0 on the bus number assigned to the PCI Express link (likely Bus 1).

The device on other side of link must be Device 0. The processor will Master Abort any Type 0 Configuration access to a non-zero device number. If there is to be more than one device on that side of the link there must be a bridge implemented in the downstream device.

When the bus number of a type 1 Standard PCI Configuration cycle or PCI Express Enhanced Configuration access is within the claimed range (between the upper bound of the bridge device's Subordinate Bus Number register and the lower bound of the bridge device's Secondary Bus Number register) but does not match the Device 1 Secondary Bus Number, a PCI Express Type 1 Configuration TLP is generated on the secondary side of the PCI Express link.

PCI Express Configuration Writes:

- Internally the processor will translate writes to PCI Express extended configuration space to configuration writes on the backbone.
- Posted writes to extended space are non-posted on the PCI Express or DMI (that is, translated to configuration writes)



2.4.5.2 DMI Configuration Accesses

Accesses to disabled processor internal devices, bus numbers not claimed by the Host-PCI Express bridge, or PCI Bus 0 devices not part of the processor will subtractively decode to the PCH and consequently be forwarded over the DMI using a PCI Express configuration TLP.

If the Bus Number is zero, the processor will generate a Type 0 Configuration cycle TLP on DMI. If the Bus Number is non-zero, and falls outside the range claimed by the Host-PCI Express bridge, the processor will generate a Type 1 Configuration cycle TLP on DMI.

The PCH routes configurations accesses in a manner similar to the processor. The PCH decodes the configuration TLP and generates a corresponding configuration access. Accesses targeting a device on PCI Bus 0 may be claimed by an internal device. The PCH compares the non-zero Bus Number with the Secondary Bus Number and Subordinate Bus Number registers of its PCI-to-PCI bridges to determine if the configuration access is meant for Primary PCI, or some other downstream PCI bus or PCI Express link.

Configuration accesses that are forwarded to the PCH, but remain unclaimed by any device or bridge will result in a master abort.

2.5 Processor Register Introduction

The processor contains two sets of software accessible registers, accessed using the Host processor I/O address space — Control registers and internal configuration registers.

- Control registers are I/O mapped into the processor I/O space, which control access to PCI and PCI Express configuration space (see section entitled I/O Mapped Registers).
- Internal configuration registers residing within the processor are partitioned into three logical device register sets ("logical" since they reside within a single physical device). The first register set is dedicated to Host Bridge functionality (that is, DRAM configuration, other chip-set operating parameters and optional features). The second register block is dedicated to Host-PCI Express Bridge functions (controls PCI Express interface configurations and operating parameters). The third register block is for the internal graphics functions.

The processor internal registers (I/O Mapped, Configuration and PCI Express Extended Configuration registers) are accessible by the Host processor. The registers that reside within the lower 256 bytes of each device can be accessed as Byte, Word (16 bit), or DWord (32 bit) quantities, with the exception of CONFIG_ADDRESS, which can only be accessed as a DWord. All multi-byte numeric fields use "little-endian" ordering (that is, lower addresses contain the least significant parts of the field). Registers that reside in bytes 256 through 4095 of each device may only be accessed using memory mapped transactions in DWord (32 bit) quantities.

Some of the processor registers described in this section contain reserved bits. These bits are labeled "Reserved". Software must deal correctly with fields that are reserved. On reads, software must use appropriate masks to extract the defined bits and not rely on reserved bits being any particular value. On writes, software must ensure that the values of reserved bit positions are preserved. That is, the values of reserved bit



positions must first be read, merged with the new values for other bit positions and then written back. Note the software does not need to perform read, merge, and write operation for the Configuration Address Register.

In addition to reserved bits within a register, the processor contains address locations in the configuration space of the Host Bridge entity that are marked either "Reserved" or "Intel Reserved". The processor responds to accesses to Reserved address locations by completing the host cycle. When a Reserved register location is read, a zero value is returned. (Reserved registers can be 8-, 16-, or 32 bits in size). Writes to Reserved registers have no effect on the processor. Registers that are marked as Intel Reserved must not be modified by system software. Writes to Intel Reserved registers may cause system failure. Reads from Intel Reserved registers may return a non-zero value.

Upon a Full Reset, the processor sets its entire set of internal configuration registers to predetermined default states. Some register values at reset are determined by external strapping options. The default state represents the minimum functionality feature set required to successfully bringing up the system. Hence, it does not represent the optimal system configuration. It is the responsibility of the system initialization software (usually BIOS) to properly determine the DRAM configurations, operating parameters and optional system features that are applicable, and to program the processor registers accordingly.

2.6 I/O Mapped Registers

The processor contains two registers that reside in the processor I/O address space - the Configuration Address (CONFIG_ADDRESS) Register and the Configuration Data (CONFIG_DATA) Register. The Configuration Address Register enables/disables the configuration space and determines what portion of configuration space is visible through the Configuration Data window.



2.7 PCI Express* Device 0 Registers

Table 2-4 shows the PCI Express Device 0 register address map. Detailed register bit descriptions follow Table 2-4.

Table 2-4. PCI Express* Device 0 Register Address Map

Offset Address	Register Symbol	Register Name	Reset Value	Access
0–1h	VID	Vendor Identification	8086h	RO
2–3h	DID	Device Identification	0040h	RO
4–5h	PCICMD	PCI Command	0006h	RO, RW
6–7h	PCISTS	PCI Status	0090h	RW1C, RO
8h	RID	Revision Identification	12h	RO
9–Bh	CC	Class Code	060000h	RO
Dh	MLT	Master Latency Timer	00h	RO
Eh	HDR	Header Type	00h	RO
2C–2Dh	SVID	Subsystem Vendor Identification	0000h	RW-O
2E–2Fh	SID	Subsystem Identification	0000h	RW-O
40–47h	PXPEPBAR	PCI Express Egress Port Base Address	0000_0000_0000_0000h	RW-L, RO
48–4Fh	MCHBAR	MCH Memory Mapped Register Range Base	0000_0000_0000_0000h	RW-L, RO
52–53h	GGC	Graphics Control Register	0030h	RW-L, RO
54–57h	DEVEN	Device Enable	0000210Bh	RW-L, RO
68–6Fh	DMIBAR	Root Complex Register Range Base Address	0000_0000_0000_0000h	RW-L, RO
97h	LAC	Legacy Access Control	00h	RW
A2–A3h	TOUUD	Top of Upper Usable DRAM	0000h	RW-L
A4–A7h	GBSM	Graphics Base of Pre-Allocated Memory	0000_0000h	RW-L, RO
A8–ABh	BGSM	Base of GTT Pre-allocated memory	0000_0000h	RW-L, RO
AC–AFh	TSEGMB	TSEG Memory Base	0000_0000h	RO, RW-L
B0–B1h	TOLUD	Top of Low Usable DRAM	0010h	RW-L, RO
C0–C3h	PBFC	Primary Buffer Flush Control	0000_0000h	RO, W
C4–C7h	SBFC	Secondary Buffer Flush Control	0000_0000h	RO, W
C8–C9h	ERRSTS	Error Status	0000h	RO, RW1C-S
CA–CBh	ERRCMD	Error Command	0000h	RO, RW
DC–DFh	SKPD	Scratchpad Data	0000_0000h	RW
E0–EBh	CAPIDO	Capability Identifier	SKU dependent	RO
F4h	MCSAMPML	Memory Configuration, System Address Map and Pre-allocated Memory Lock	00h	RW-O, RW-L, RW-L-K



2.7.1 VID—Vendor Identification Register

This register combined with the Device Identification register uniquely identifies any PCI device.

B/D/F/Type:		0/0/0/PCI	
Address Offset:		0–1h	
Reset Value:		8086h	
Access:		RO	
Bit	Attr	Reset Value	Description
15:0	RO	8086h	Vendor Identification Number (VID) PCI standard identification for Intel.

2.7.2 DID—Device Identification Register

This register combined with the Vendor Identification register uniquely identifies any PCI device.

B/D/F/Type:		0/0/0/PCI	
Address Offset:		2–3h	
Reset Value:		0040h	
Access:		RO	
Bit	Attr	Reset Value	Description
15:0	RO	0040h	Device Identification Number (DID) Identifier assigned to the processor core/primary PCI device.

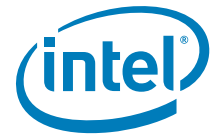

2.7.3 PCICMD—PCI Command Register

Since processor Device 0 does not physically reside on PCI_A many of the bits are not implemented.

B/D/F/Type:		0/0/0/PCI	
Address Offset:		4–5h	
Reset Value:		0006h	
Access:		RO, RW	
Bit	Attr	Reset Value	Description
15:10	RO	00h	Reserved
9	RO	0b	Fast Back-to-Back Enable (FB2B) This bit controls whether or not the master can do fast back-to-back write. Since device 0 is strictly a target this bit is not implemented and is hardwired to 0. Writes to this bit position have no effect.
8	RW	0b	SERR Enable (SERRE) This bit is a global enable bit for Device 0 SERR messaging. The processor does not have an SERR signal. The processor communicates the SERR condition by sending an SERR message over DMI to the PCH. 1 = The processor is enabled to generate SERR messages over DMI for specific Device 0 error conditions that are individually enabled in the ERRCMD and DMIUEMSK registers. The error status is reported in the ERRSTS, PCISTS, and DMIUEST registers. 0 = The SERR message is not generated by the processor for Device 0. This bit only controls SERR messaging for Device 0. Device 1 has its own SERRE bits to control error reporting for error conditions occurring in that device. The control bits are used in a logical OR manner to enable the SERR DMI message mechanism. 0 = Device 0 SERR disabled 1 = Device 0 SERR enabled
7	RO	0b	Address/Data Stepping Enable (ADSTEP) Address/data stepping is not implemented in the processor, and this bit is hardwired to 0. Writes to this bit position have no effect.
6	RW	0b	Parity Error Enable (PERRE) This bit controls whether or not the Master Data Parity Error bit in the PCI Status register can be set. 0 = Master Data Parity Error bit in PCI Status register can NOT be set. 1 = Master Data Parity Error bit in PCI Status register CAN be set.
5	RO	0b	VGA Palette Snoop Enable (VGASNOOP) The processor does not implement this bit and it is hardwired to a 0. Writes to this bit position have no effect.
4	RO	0b	Memory Write and Invalidate Enable (MWIE) The processor will never issue memory write and invalidate commands. This bit is therefore hardwired to 0. Writes to this bit position will have no effect.
3:3	RO	0h	Reserved
2	RO	1b	Bus Master Enable (BME) The processor is always enabled as a master on the backbone. This bit is hardwired to a 1. Writes to this bit position have no effect.
1	RO	1b	Memory Access Enable (MAE) The processor always allows access to main memory, except when such access would violate security principles. Such exceptions are outside the scope of PCI control. This bit is not implemented and is hardwired to 1. Writes to this bit position have no effect.
0	RO	0b	I/O Access Enable (IOAE) This bit is not implemented in the processor and is hardwired to a 0. Writes to this bit position have no effect.

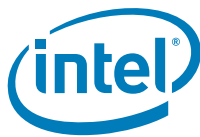

2.7.4 PCISTS—PCI Status Register

This status register reports the occurrence of error events on Device 0's PCI interface. Since the processor Device 0 does not physically reside on PCI_A, many of the bits are not implemented.

B/D/F/Type:		0/0/0/PCI	
Address Offset:		6–7h	
Reset Value:		0090h	
Access:		RW1C, RO	
Bit	Attr	Reset Value	Description
15	RW1C	0b	Detected Parity Error (DPE) This bit is set when this device receives a Poisoned TLP.
14	RW1C	0b	Signaled System Error (SSE) This bit is set to 1 when the processor Device 0 generates an SERR message over DMI for any enabled Device 0 error condition. Device 0 error conditions are enabled in the PCICMD, ERRCMD, and DMIUEMSK registers. Device 0 error flags are read/reset from the PCISTS, ERRSTS, or DMIUEST registers. Software clears this bit by writing a 1 to it.
13	RW1C	0b	Received Master Abort Status (RMAS) This bit is set when the processor generates a DMI request that receives an Unsupported Request completion packet. Software clears this bit by writing a 1 to it.
12	RW1C	0b	Received Target Abort Status (RTAS) This bit is set when the processor generates a DMI request that receives a Completer Abort completion packet. Software clears this bit by writing a 1 to it.
11	RO	0b	Signaled Target Abort Status (STAS) The processor will not generate a Target Abort DMI completion packet or Special Cycle. This bit is not implemented in the processor and is hardwired to a 0. Writes to this bit position have no effect.
10:9	RO	00b	DEVSEL Timing (DEVT) These bits are hardwired to "00". Writes to these bit positions have no affect. Device 0 does not physically connect to PCI_A. These bits are set to "00" (fast decode) so that optimum DEVSEL timing for PCI_A is not limited by the processor.
8	RW1C	0b	Master Data Parity Error Detected (DPD) This bit is set when DMI received a Poisoned completion from PCH. This bit can only be set when the Parity Error Enable bit in the PCI Command register is set.
7	RO	1b	Fast Back-to-Back (FB2B) This bit is hardwired to 1. Writes to these bit positions have no effect. Device 0 does not physically connect to PCI_A. This bit is set to 1 (indicating fast back-to-back capability) so that the optimum setting for PCI_A is not limited by the processor.
6	RO	0b	Reserved
5	RO	0b	66 MHz Capable (66MC) Does not apply to PCI Express. Must be hardwired to 0.
4	RO	1b	Capability List (CLIST) This bit is hardwired to 1 to indicate to the configuration software that this device/function implements a list of new capabilities. A list of new capabilities is accessed using register CAPPTR at configuration address offset 34h. Register CAPPTR contains an offset pointing to the start address within configuration space of this device where the Capability Identification register resides.
3	RO	0b	Reserved
2:0	RO	000b	Reserved



2.7.5 RID—Revision Identification

This register contains the revision number of the processor. The Revision ID (RID) is a traditional 8-bit Read Only (RO) register located at offset 08h in the standard PCI header of every PCI/PCI Express compatible device and function.

B/D/F/Type:		0/0/0/PCI	
Address Offset:		8h	
Reset Value:		08h	
Access:		RO	
Bit	Attr	Reset Value	Description
7:0	RO	12h	Revision Identification Number (RID) This is an 8-bit value that indicates the revision identification number for the processor Device 0. Refer to the <i>Intel® Core™ i5-600 and i3-500 Desktop Processor Series and Intel® Pentium® Desktop Processor 6000 Series Specification Update</i> for the value of the Revision ID Register.

2.7.6 CC—Class Code Register

This register identifies the basic function of the device, a more specific sub-class, and a register-specific programming interface.

B/D/F/Type:		0/0/0/PCI	
Address Offset:		9–Bh	
Reset Value:		060000h	
Access:		RO	
Bit	Attr	Reset Value	Description
23:16	RO	06h	Base Class Code (BCC) This is an 8-bit value that indicates the base class code for the processor. This code has the value 06h, indicating a Bridge device.
15:8	RO	00h	Sub-Class Code (SUBCC) This is an 8-bit value that indicates the category of Bridge into which the processor falls. The code is 00h indicating a Host Bridge.
7:0	RO	00h	Programming Interface (PI) This is an 8-bit value that indicates the programming interface of this device. This value does not specify a particular register set layout and provides no practical use for this device.

2.7.7 MLT—Master Latency Timer Register

Device 0 in the processor is not a PCI master. Therefore, this register is not implemented.

B/D/F/Type:		0/0/0/PCI	
Address Offset:		Dh	
Reset Value:		00h	
Access:		RO	
Bit	Attr	Reset Value	Description
7:0	RO	00h	Reserved



2.7.8 HDR—Header Type Register

This register identifies the header layout of the configuration space. No physical register exists at this location.

B/D/F/Type:		0/0/0/PCI	
Address Offset:		Eh	
Reset Value:		00h	
Access:		RO	
Bit	Attr	Reset Value	Description
7:0	RO	00h	PCI Header (HDR) This field always returns 0 to indicate that the processor is a single function device with standard header layout. Reads and writes to this location have no effect.

2.7.9 SVID—Subsystem Vendor Identification Register

This value is used to identify the vendor of the subsystem.

B/D/F/Type:		0/0/0/PCI	
Address Offset:		2C–2Dh	
Reset Value:		0000h	
Access:		RW-O	
Bit	Attr	Reset Value	Description
15:0	RW-O	0000h	Subsystem Vendor ID (SUBVID) This field should be programmed during boot-up to indicate the vendor of the system board. After it has been written once, it becomes read only.



2.7.10 SID—Subsystem Identification Register

This value is used to identify a particular subsystem.

B/D/F/Type:		0/0/0/PCI	
Address Offset:		2E–2Fh	
Reset Value:		0000h	
Access:		RW-O	
Bit	Attr	Reset Value	Description
15:0	RW-O	0000h	Subsystem ID (SUBID) This field should be programmed during BIOS initialization. After it has been written once, it becomes read only.

2.7.11 PXPEPBAR—PCI Express Egress Port Base Address Register

This is the base address for the PCI Express Egress Port MMIO Configuration space. There is no physical memory within this 4 KB window that can be addressed. The 4 KB reserved by this register does not alias to any PCI 2.3 compliant memory mapped space. On reset, the EGRESS port MMIO configuration space is disabled and must be enabled by writing a 1 to PXPEPBAREN [Device 0, offset 40h, bit 0].

All the bits in this register are locked in Intel TXT mode.

B/D/F/Type:		0/0/0/PCI	
Address Offset:		40–47h	
Reset Value:		0000_0000_0000_0000h	
Access:		RW-L, RO	
Bit	Attr	Reset Value	Description
63:36	RO	0000000h	Reserved
35:12	RW-L	000000h	PCI Express Egress Port MMIO Base Address (PXPEPBAR) This field corresponds to bits 35:12 of the base address PCI Express Egress Port MMIO configuration space. BIOS will program this register resulting in a base address for a 4 KB block of contiguous memory address space. This register ensures that a naturally aligned 4 KB space is allocated within the first 64 GB of addressable memory space. System Software uses this base address to program the processor MMIO register set. All the bits in this register are locked in Intel TXT mode.
11:1	RO	000h	Reserved
0	RW-L	0b	PXPEPBAR Enable (PXPEPBAREN) 0 = Disable. PXPEPBAR is disabled and does not claim any memory 1 = Enable. PXPEPBAR memory mapped accesses are claimed and decoded appropriately This register is locked by Intel TXT.



2.7.12 MCHBAR—MCH Memory Mapped Register Range Base Register

This is the base address for the processor memory mapped configuration space. There is no physical memory within this 16 KB window that can be addressed. The 16 KB reserved by this register does not alias to any PCI 2.3 compliant memory mapped space. On reset, the processor MMIO memory mapped configuration space is disabled and must be enabled by writing a 1 to MCHBAREN [Device 0, offset 48h, bit 0].

All the bits in this register are locked in Intel TXT mode.

The register space contains memory control, initialization, timing, and buffer strength registers — clocking registers and power and thermal management registers. The 16 KB space reserved by the MCHBAR register is not accessible during Intel TXT mode of operation or if the ME security lock is asserted (MESMLCK.ME_SM_lock at PCI device 0, function 0, offset F4h) except for the following offset ranges.

02B8h to 02BFh: Channel 0 Throttle Counter Status Registers

06B8h to 06BFh: Channel 1 Throttle Counter Status Registers

0CD0h to 0CFFh: Thermal Sensor Control Registers

3000h to 3FFFh: Unlocked registers for future expansion

B/D/F/Type:		0/0/0/PCI	
Address Offset:		48–4Fh	
Reset Value:		0000_0000_0000_0000h	
Access:		RW-L, RO	
Bit	Attr	Reset Value	Description
63:36	RO	0000000h	Reserved
35:14	RW-L	000000h	MCH Memory Mapped Base Address (MCHBAR) This field corresponds to bits 35:4 of the base address processor memory mapped configuration space. BIOS will program this register resulting in a base address for a 16 KB block of contiguous memory address space. This register ensures that a naturally aligned 16 KB space is allocated within the first 64 GB of addressable memory space. System Software uses this base address to program the processor memory mapped register set. All the bits in this register are locked in Intel TXT mode.
13:1	RO	0000h	Reserved
0	RW-L	0b	MCHBAR Enable (MCHBAREN) 0 = Disable. MCHBAR is disabled and does not claim any memory 1 = Enable. MCHBAR memory mapped accesses are claimed and decoded appropriately This register is locked by Intel TXT.

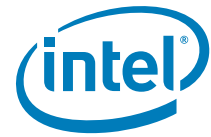

2.7.13 GGC—Graphics Control Register

All the bits in this register are Intel TXT lockable.

B/D/F/Type:		0/0/0/PCI	
Address Offset:		52–53h	
Reset Value:		0030h	
Access:		RW-L, RO	
Bit	Attr	Reset Value	Description
15:12	RO	0h	Reserved
11:8	RW-L	0h	<p>GTT Graphics Memory Size (GMS)</p> <p>This field is used to select the amount of main memory that is pre-allocated to support the Internal Graphics Translation Table. The BIOS ensures that memory is pre-allocated only when internal graphics is enabled. Memory pre-allocated for internal graphics is assumed to be a contiguous physical DRAM space with memory pre-allocated for data, and BIOS needs to allocate a contiguous memory chunk. Hardware will drive the base of memory pre-allocated for internal graphics from memory pre-allocated for data, only using the memory pre-allocated for graphics size programmed in the register.</p> <p>0h = No memory pre-allocated. GTT cycles (memory and I/O) are not claimed.</p> <p>1h =No VT mode, 1 MB of memory pre-allocated for GTT.</p> <p>3h =No VT mode, 2 MB of memory pre-allocated for GTT.</p> <p>9h =VT mode, 2 MB of memory pre-allocated for 1 MB of Global GTT and 1 MB for Shadow GTT.</p> <p>Ah =VT mode, 3 MB of memory pre-allocated for 1.5 MB of Global GTT and 1.5 MB for Shadow GTT.</p> <p>Bh =VT mode, 4 MB of memory pre-allocated for 2 MB of Global GTT and 2 MB for Shadow GTT.</p> <p>All unspecified encodings of this register field are reserved, hardware functionality is not ensured if used.</p> <p>This register is locked and becomes read only when CMD.LOCK.MEMCONFIG is received or when ME_SM_LOCK is set to 1.</p>
7:4	RW-L	3h	<p>Graphics Mode Select (GMS)</p> <p>This field is used to select the amount of Main Memory that is pre-allocated to support the Internal Graphics device in VGA (non-linear) and Native (linear) modes. The BIOS ensures that memory is pre-allocated only when Internal graphics is enabled.</p> <p>0h = No memory pre-allocated. Device 2 (IGD) does not claim VGA cycles (Memory and IO), and the Sub-Class Code field within Device 2, Function 0 Class Code register is 80h.</p> <p>1h-4h = Reserved.</p> <p>5h-Dh = DVMT (UMA) mode, memory pre-allocated for frame buffer, in quantities as shown in the Encoding table.</p> <p>Eh-Fh = Reserved.</p> <p>This register is locked and becomes read only when CMD.LOCK.MEMCONFIG is received or when ME_SM_LOCK is set to 1.</p> <p>Hardware does not clear or set any of these bits automatically based on IGD being disabled/enabled.</p> <p>BIOS Requirement: BIOS must not set this field to 0h if IVD (bit 1 of this register) is 0.</p> <p>0h = No memory pre-allocated</p> <p>5h = 32 MB</p> <p>6h = 48 MB</p> <p>7h = 64 MB</p> <p>8h = 128 MB</p> <p>9h = 256 MB</p> <p>Ah = 96 MB</p> <p>Bh = 160 MB</p> <p>Ch = 224 MB</p> <p>Dh = 352 MB</p>

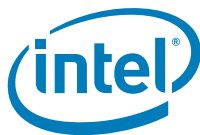

B/D/F/Type:		0/0/0/PCI	
Address Offset:		52–53h	
Reset Value:		0030h	
Access:		RW-L, RO	
Bit	Attr	Reset Value	Description
3:2	RO	00b	Reserved
1	RW-L	0b	<p>IGD VGA Disable (IVD): 0 = Enable. Device 2 (IGD) claims VGA memory and IO cycles, the Sub-Class Code within Device 2 Class Code register is 00. 1 = Disable. Device 2 (IGD) does not claim VGA cycles (Memory and IO), and the Sub- Class Code field within Device 2 function 0 Class Code register is 80.</p> <p>BIOS Requirement: BIOS must not set this bit to 0 if the GMS field (bits 6:4 of this register) pre-allocates no memory. This bit MUST be set to 1 if Device 2 is disabled either using a fuse or fuse override (CAPID0[46] = 1) or using a register (DEVEN[3] = 0).</p> <p>This register is locked and becomes Read Only when CMD.LOCK.MEMCONFIG is received or when ME_SM_LOCK is set to 1.</p>
0	RO	0b	Reserved

2.7.14 DEVEN—Device Enable Register

This register allows for enabling/disabling of PCI devices and functions that are within the processor. The table below describes the behavior of all combinations of transactions to devices controlled by this register. All the bits in this register are Intel TXT Lockable.

B/D/F/Type:		0/0/0/PCI	
Address Offset:		54–57h	
Reset Value:		0000_210Bh	
Access:		RW-L, RO	
BIOS Optimal Reset Value		000000h	
Bit	Attr	Reset Value	Description
31:4	RO	0h	Reserved
1	RW-L	1b	<p>PCI Express Port (D6EN) 0 = Bus 0, Device 1, Function 0 is disabled and hidden. 1 = Bus 0, Device 1, Function 0 is enabled and visible.</p>
12:4	RO	00h	Reserved
3	RW-L	1b	<p>Internal Graphics Engine Function 0 (D2FOEN) 0 = Bus 0, Device 2, Function 0 is disabled and hidden 1 = Bus 0, Device 2, Function 0 is enabled and visible If this processor does not have internal graphics capability, then Device 2, Function 0 is disabled and hidden independent of the state of this bit.</p>
2	RO	0h	Reserved
1	RW-L	1b	<p>PCI Express Port (D1EN) 0 = Bus 0, Device 1, Function 0 is disabled and hidden. 1 = Bus 0, Device 1, Function 0 is enabled and visible.</p>
0	RO	1b	<p>Host Bridge (DOEN) Bus 0: Device 0, Function 0 may not be disabled and is therefore hardwired to 1.</p>

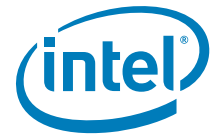

2.7.15 DMIBAR—Root Complex Register Range Base Address Register

This is the base address for the Root Complex configuration space. This window of addresses contains the Root Complex Register set for the PCI Express Hierarchy associated with the processor. There is no physical memory within this 4 KB window that can be addressed. The 4 KB reserved by this register does not alias to any PCI 2.3 compliant memory mapped space. On reset, the Root Complex configuration space is disabled and must be enabled by writing a 1 to DMIBAREN [Device 0, offset 68h, bit 0]. All the bits in this register are locked in Intel TXT mode.

B/D/F/Type:		0/0/0/PCI0000_0	
Address Offset:		68–6Fh	
Reset Value:		0000_0000_0000_0000h	
Access:		RW-L, RO	
Bit	Attr	Reset Value	Description
63:36	RO	0000000h	Reserved (DMIBAR_rsv)
35:12	RW-L	000000h	DMI Base Address (DMIBAR) This field corresponds to bits 35:12 of the base address DMI configuration space. BIOS will program this register resulting in a base address for a 4 KB block of contiguous memory address space. This register ensures that a naturally aligned 4 KB space is allocated within the first 64 GB of addressable memory space. System software uses this base address to program the DMI register set. All the bits in this register are locked in Intel TXT mode.
11:1	RO	000h	Reserved
0	RW-L	0b	DMIBAR Enable (DMIBAREN) 0 = Disable. DMIBAR is disabled and does not claim any memory 1 = Enable. DMIBAR memory mapped accesses are claimed and decoded appropriately This register is locked by Intel TXT.



2.7.16 LAC—Legacy Access Control Register

This 8-bit register controls steering of MDA cycles.

There can only be at most one MDA device in the system. BIOS must not program bits 1:0 to 11b.

B/D/F/Type:		0/0/0/PCI																
Address Offset:		97h																
Reset Value:		00h																
Access:		RW																
BIOS Optimal Reset Value		00h																
Bit	Attr	Reset Value	Description															
7:2	RO	0h	Reserved															
1	RW	0b	<p>PEG1 MDA Present (MDAP1)</p> <p>This bit works with the VGA Enable bits in the BCTRL register of Device 6 to control the routing of processor initiated transactions targeting MDA compatible I/O and memory address ranges. This bit should not be set if device 6's VGA Enable bit is not set.</p> <p>If device 6's VGA enable bit is not set, then accesses to IO address range x3BCh–x3BFh remain on the backbone.</p> <p>If the VGA enable bit is set and MDA is not present, then accesses to IO address range x3BCh–x3BFh are forwarded to PCI Express through device 6 if the address is within the corresponding IOBASE and IOLIMIT, otherwise they remain on the backbone.</p> <p>MDA resources are defined as the following:</p> <p>Memory: 0B0000h – 0B7FFFh</p> <p>I/O: 3B4h, 3B5h, 3B8h, 3B9h, 3BAh, 3BFh (including ISA address aliases, A[15:10] are not used in decode)</p> <p>Any I/O reference that includes the I/O locations listed above, or their aliases, will remain on the backbone even if the reference also includes I/O locations not listed above.</p> <p>The following table shows the behavior for all combinations of MDA and VGA:</p> <table border="1"> <thead> <tr> <th>VGAEN</th> <th>MDAP</th> <th>Description</th> </tr> </thead> <tbody> <tr> <td>0</td> <td>0</td> <td>All References to MDA and VGA space are not claimed by Device 6.</td> </tr> <tr> <td>0</td> <td>1</td> <td>Illegal combination</td> </tr> <tr> <td>1</td> <td>0</td> <td>All VGA and MDA references are routed to PCI Express Graphics Attach device 6.</td> </tr> <tr> <td>1</td> <td>1</td> <td>All VGA references are routed to PCI Express Graphics Attach device 6. MDA references are not claimed by device 6.</td> </tr> </tbody> </table> <p>VGA and MDA memory cycles can only be routed across PEG1 when MAE (PCICMD6[1]) is set. VGA and MDA I/O cycles can only be routed across PEG1 if IOAE (PCICMD6[0]) is set.</p> <p>0 = No MDA 1 = MDA Present</p>	VGAEN	MDAP	Description	0	0	All References to MDA and VGA space are not claimed by Device 6.	0	1	Illegal combination	1	0	All VGA and MDA references are routed to PCI Express Graphics Attach device 6.	1	1	All VGA references are routed to PCI Express Graphics Attach device 6. MDA references are not claimed by device 6.
VGAEN	MDAP	Description																
0	0	All References to MDA and VGA space are not claimed by Device 6.																
0	1	Illegal combination																
1	0	All VGA and MDA references are routed to PCI Express Graphics Attach device 6.																
1	1	All VGA references are routed to PCI Express Graphics Attach device 6. MDA references are not claimed by device 6.																

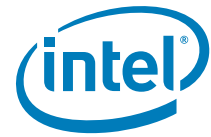

B/D/F/Type: 0/0/0/PCI Address Offset: 97h Reset Value: 00h Access: RW BIOS Optimal Reset Value 00h																		
Bit	Attr	Reset Value	Description															
0	RW	0b	<p>PEGO MDA Present (MDAPO)</p> <p>This bit works with the VGA Enable bits in the BCTRL register of Device 1 to control the routing of processor initiated transactions targeting MDA compatible I/O and memory address ranges. This bit should not be set if device 1's VGA Enable bit is not set.</p> <p>If device 1's VGA enable bit is not set, then accesses to I/O address range x3BCh–x3BFh remain on the backbone.</p> <p>If the VGA enable bit is set and MDA is not present, accesses to I/O address range x3BCh–x3BFh are forwarded to PCI Express through device 1 if the address is within the corresponding IOBASE and IOLIMIT; otherwise, they remain on the backbone.</p> <p>MDA resources are defined as the following: Memory: 0B0000h – 0B7FFFh I/O: 3B4h, 3B5h, 3B8h, 3B9h, 3BAh, 3BFh (including ISA address aliases, A[15:10] are not used in decode)</p> <p>Any I/O reference that includes the I/O locations listed above, or their aliases, will remain on the backbone even if the reference also includes I/O locations not listed above.</p> <p>The following table shows the behavior for all combinations of MDA and VGA:</p> <table border="1"> <thead> <tr> <th>VGAEN</th> <th>MDAP</th> <th>Description</th> </tr> </thead> <tbody> <tr> <td>0</td> <td>0</td> <td>All References to MDA and VGA space are not claimed by Device 1.</td> </tr> <tr> <td>0</td> <td>1</td> <td>Illegal combination</td> </tr> <tr> <td>1</td> <td>0</td> <td>All VGA and MDA references are routed to PCI Express Graphics Attach device 1.</td> </tr> <tr> <td>1</td> <td>1</td> <td>All VGA references are routed to PCI Express Graphics Attach device 1. MDA references are not claimed by device 1.</td> </tr> </tbody> </table> <p>VGA and MDA memory cycles can only be routed across PEGO when MAE (PCICMD1[1]) is set. VGA and MDA I/O cycles can only be routed across PEGO if IOAE (PCICMD1[0]) is set.</p> <p>0 = No MDA 1 = MDA Present</p>	VGAEN	MDAP	Description	0	0	All References to MDA and VGA space are not claimed by Device 1.	0	1	Illegal combination	1	0	All VGA and MDA references are routed to PCI Express Graphics Attach device 1.	1	1	All VGA references are routed to PCI Express Graphics Attach device 1. MDA references are not claimed by device 1.
VGAEN	MDAP	Description																
0	0	All References to MDA and VGA space are not claimed by Device 1.																
0	1	Illegal combination																
1	0	All VGA and MDA references are routed to PCI Express Graphics Attach device 1.																
1	1	All VGA references are routed to PCI Express Graphics Attach device 1. MDA references are not claimed by device 1.																



2.7.17 TOUUD—Top of Upper Usable DRAM Register

This 16 bit register defines the Top of Upper Usable DRAM.

Configuration software must set this value to TOM minus all EP pre-allocated memory if reclaim is disabled. If reclaim is enabled, this value must be set to reclaim limit + 1byte, 64 MB aligned, since reclaim limit is 64 MB aligned. Address bits 19:0 are assumed to be 000_0000h for the purposes of address comparison. The Host interface positively decodes an address towards DRAM if the incoming address is less than the value programmed in this register and greater than or equal to 4 GB.

These bits are Intel TXT lockable.

B/D/F/Type:		0/0/0/PCI	
Address Offset:		A2–A3h	
Reset Value:		0000h	
Access:		RW-L	
Bit	Attr	Reset Value	Description
15:0	RW-L	0000h	<p>TOUUD (TOUUD)</p> <p>This register contains bits 35:20 of an address one byte above the maximum DRAM memory above 4 GB that is usable by the operating system. Configuration software must set this value to TOM minus all EP pre-allocated memory if reclaim is disabled. If reclaim is enabled, this value must be set to reclaim limit 64 MB aligned since reclaim limit + 1byte is 64 MB aligned. Address bits 19:0 are assumed to be 000_0000h for the purposes of address comparison. The Host interface positively decodes an address towards DRAM if the incoming address is less than the value programmed in this register and greater than 4 GB.</p> <p>All the bits in this register are locked in Intel TXT mode.</p>

2.7.18 GBSM— Graphics Base of Pre-allocated Memory Register

This register contains the base address of DRAM memory pre-allocated for graphics data. BIOS determines the base of memory pre-allocated for graphics by subtracting the graphics data pre-allocated memory size (PCI Device 0, offset 52h, bits 7:4) from TOLUD (PCI Device 0, offset B0h, bits 15:4).

This register is locked and becomes read only when CMD.LOCK.MEMCONFIG is received or when ME_SM_LOCK is set to 1.

B/D/F/Type:		0/0/0/PCI	
Address Offset:		A4–A7h	
Reset Value:		0000_0000h	
Access:		RW-L, RO	
Bit	Attr	Reset Value	Description
31:20	RW-L	000h	<p>Graphics Base of Pre-allocated Memory (GBSM)</p> <p>This register contains bits 31:20 of the base address of DRAM memory pre-allocated for graphics. BIOS determines the base of memory pre-allocated for graphics by subtracting the pre-allocated memory size (PCI Device 0, offset 52h, bits 6:4) from TOLUD (PCI Device 0, offset B0h, bits 15:4).</p> <p>This register is locked and becomes Read Only when CMD.LOCK.MEMCONFIG is received or when ME_SM_LOCK is set to 1.</p>
19:0	RO	00000h	Reserved

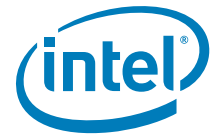

2.7.19 BGSM—Base of GTT Pre-allocated Memory Register

This register contains the base address of DRAM memory pre-allocated for the GTT. BIOS determines the base of pre-allocated GTT memory by subtracting the GTT graphics memory pre-allocated size (PCI Device 0, offset 52h, bits 11:8) from the Base of memory pre-allocated for graphics (PCI Device 0, offset A4h, bits 31:20).

This register is locked and becomes Read Only when CMD.LOCK.MEMCONFIG is received or when ME_SM_LOCK is set to 1.

B/D/F/Type:		0/0/0/PCI	
Address Offset:		A8-ABh	
Reset Value:		0000_0000h	
Access:		RW-L, RO	
Bit	Attr	Reset Value	Description
31:20	RW-L	000h	Memory Pre-allocated for graphics (MPG) This register contains bits 31:20 of the base address of pre-allocated DRAM memory. BIOS determines the base of memory pre-allocated for graphics by subtracting the graphics pre-allocated memory size (PCI Device 0, offset 52h, bits 9:8) from the graphics pre-allocated memory base (PCI Device 0, offset A4h, bits 31:20). This register is locked and becomes Read Only when CMD.LOCK.MEMCONFIG is received or when ME_SM_LOCK is set to 1.
19:0	RO	00000h	Reserved

2.7.20 TSEGMB—TSEG Memory Base Register

This register contains the base address of TSEG DRAM memory. BIOS determines the base of TSEG memory which must be at or below memory pre-allocated for graphics (PCI Device 0, offset A8h, bits 31:20).

This register is locked and becomes Read Only when CMD.LOCK.MEMCONFIG is received or when ME_SM_LOCK is set to 1.

B/D/F/Type:		0/0/0/PCI	
Address Offset:		AC-AFh	
Reset Value:		0000_0000h	
Access:		RO, RW-L	
Bit	Attr	Reset Value	Description
31:20	RW-L	000h	TSEG Memory base (TSEGMB) This register contains bits 31:20 of the base address of TSEG DRAM memory. BIOS determines the base of TSEG memory by subtracting the TSEG size (PCI Device 0, offset 9Eh, bits 2:1) from graphics GTT memory pre-allocated for graphics base (PCI Device 0, offset A8h, bits 31:20). This register is locked and becomes read only when CMD.LOCK.MEMCONFIG is received or when ME_SM_LOCK is set to 1.
19:0	RO	00000h	Reserved



2.7.21 TOLUD—Top of Low Usable DRAM Register

This 16-bit register defines the Top of Low Usable DRAM. TSEG, GTT Graphics memory, and Memory pre-allocated for graphics are within the usable DRAM space defined.

Programming Example:

C1DRB3 is set to 5 GB

BIOS knows the OS requires 1 GB of PCI space.

BIOS also knows the range from 0_FECO_0000h to 0_FFFF_FFFFh is not usable by the system. This 20 MB range at the very top of addressable memory space is lost to APIC and Intel TXT.

According to the above information, TOLUD is originally calculated to:
 4 GB = 1_0000_0000h

The system memory requirements are: 4 GB – 1 GB (PCI space) – 20 MB (lost memory)

Due to the minimum granularity of the REMAPBASE and REMAPLIMIT registers, this becomes 3 GB – 64 MB = 0_BC00_0000h

Since 0_BC00_0000h (PCI and other system requirements) is less than 1_0000_0000h, TOLUD should be programmed to BC0h.

These bits are Intel TXT lockable.

B/D/F/Type:		O/O/O/PCI	
Address Offset:		B0–B1h	
Reset Value:		0010h	
Access:		RW-L, RO	
Bit	Attr	Reset Value	Description
15:4	RW-L	001h	<p>Top of Low Usable DRAM (TOLUD)</p> <p>This register contains bits 31:20 of an address one byte above the maximum DRAM memory below 4 GB that is usable by the operating system. Address bits 31:20 programmed to 01h implies a minimum memory size of 1 MB. Configuration software must set this value to the smaller of the following 2 choices: maximum amount memory in the system minus memory pre-allocated for ME plus one byte or the minimum address allocated for PCI memory.</p> <p>Address bits 19:0 are assumed to be 0_0000h for the purposes of address comparison. The Host interface positively decodes an address towards DRAM if the incoming address is less than the value programmed in this register.</p> <p>The Top of Low Usable DRAM is the lowest address above both memory pre-allocated for graphics and TSEG. BIOS determines the base of memory pre-allocated for graphics by subtracting the memory pre-allocated for Graphics Size from TOLUD and further decrements by TSEG size to determine the base of TSEG. All the bits in this register are locked in Intel TXT mode.</p> <p>This register must be 64 MB aligned when reclaim is enabled.</p>
3:0	RO	0h	Reserved



2.7.22 PBFC—Primary Buffer Flush Control Register

B/D/F/Type:		0/0/0/PCI	
Address Offset:		C0–C3h	
Reset Value:		0000_0000h	
Access:		RO, W	
Bit	Attr	Reset Value	Description
31:1	RO	0h	Reserved
0	W	0b	Primary CWB Flush Control (PCWBFLSH) A processor write to this bit flushes the PCWB of all writes. The data associated with the write to this register is discarded.

2.7.23 SBFC—Secondary Buffer Flush Control Register

B/D/F/Type:		0/0/0/PCI	
Address Offset:		C4–C7h	
Reset Value:		0000_0000h	
Access:		RO, W	
Bit	Attr	Reset Value	Description
31:1	RO	0h	Reserved
0	W	0b	Secondary CWB Flush Control (SCWBFLSH) A processor write to this bit flushes the SCWB of all writes. The data associated with the write to this register is discarded.



2.7.24 ERRSTS—Error Status Register

This register is used to report various error conditions using the SERR DMI messaging mechanism. An SERR DMI message is generated on a zero to one transition of any of these flags (if enabled by the ERRCMD and PCICMD registers).

These bits are set regardless of whether or not the SERR is enabled and generated. After the error processing is complete, the error logging mechanism can be unlocked by clearing the appropriate status bit, by software writing a 1 to it.

B/D/F/Type:		0/0/0/PCI	
Address Offset:		C8–C9h	
Reset Value:		0000h	
Access:		RO, RW1C-S	
BIOS Optimal Reset Value		0h	
Bit	Attr	Reset Value	Description
15:13	RO	000b	Reserved
12	RW1C-S	0b	Processor Software Generated Event for SMI (GSGESMI) This bit indicates the source of the SMI was a Device 2 Software Event.
11	RW1C-S	0b	Processor Thermal Sensor Event for SMI/SCI/SERR (GTSE) This bit indicates that a processor Thermal Sensor trip has occurred and an SMI, SCI or SERR has been generated. The status bit is set only if a message is sent based on thermal event enables in Error command, SMI command and SCI command registers. A trip point can generate one of SMI, SCI, or SERR interrupts (two or more per event is illegal). Multiple trip points can generate the same interrupt, if software chooses this mode, subsequent trips may be lost. If this bit is already set, then an interrupt message will not be sent on a new thermal sensor event.
10	RO	0b	Reserved
9	RW1C-S	0b	LOCK to non-DRAM Memory Flag (LCKF) When this bit is set to 1, the processor has detected a lock operation to memory space that did not map into DRAM.
8:2	RO	0b	Reserved
1	RW1C-S	0b	Reserved
0	RW1C-S	0b	Reserved



2.7.25 ERRCMD—Error Command Register

This register controls the processor responses to various system errors. Since the processor does not have an SERR# signal, SERR messages are passed from the processor to the PCH over DMI.

When a bit in this register is set, a SERR message will be generated on DMI whenever the corresponding flag is set in the ERRSTS register. The actual generation of the SERR message is globally enabled for Device 0 using the PCI Command register.

B/D/F/Type: Address Offset: Reset Value: Access:		0/0/0/PCI CA-CBh 0000h RO, RW	
Bit	Attr	Reset Value	Description
15:12	RO	0h	Reserved
11	RW	0b	SERR on Processor Thermal Sensor Event (TSESERR) 1 = The processor generates a DMI SERR special cycle when bit 11 of the ERRSTS is set. The SERR must not be enabled at the same time as the SMI for the same thermal sensor event. 0 = Reporting of this condition using SERR messaging is disabled.
10	RO	0b	Reserved
9	RW	0b	SERR on LOCK to non-DRAM Memory (LCKERR) 1 = The processor will generate a DMI SERR special cycle whenever a processor lock cycle is detected that does not hit DRAM. 0 = Reporting of this condition using SERR messaging is disabled.
8	RW	0b	Reserved
7:2	RO	0h	Reserved
1	RW	0b	Reserved
0	RW	0b	Reserved



2.7.26 SMICMD—SMI Command Register

This register enables various errors to generate an SMI DMI special cycle. When an error flag is set in the ERRSTS register, it can generate an SERR, SMI, or SCI DMI special cycle when enabled in the ERRCMD, SMICMD, or SCICMD registers, respectively. Note that one and only one message type can be enabled.

B/D/F/Type:		0/0/0/PCI	
Address Offset:		CC-CDh	
Reset Value:		0000h	
Access:		RO, RW	
Bit	Attr	Reset Value	Description
15:12	RO	0h	Reserved
11	RW	0b	SMI on Processor Thermal Sensor Trip (TSTSMI) 1 = A SMI DMI special cycle is generated by the processor when the thermal sensor trip requires an SMI. A thermal sensor trip point cannot generate more than one special cycle. 0 = Reporting of this condition using SMI messaging is disabled.
10:2	RO	000h	Reserved
1	RW	0b	Reserved
0	RW	0b	Reserved

2.7.27 SKPD—Scratchpad Data Register

This register holds 32 writable bits with no functionality behind them. It is for the convenience of BIOS and graphics drivers.

B/D/F/Type:		0/0/0/PCI	
Address Offset:		DC-DFh	
Reset Value:		0000_0000h	
Access:		RW	
Bit	Attr	Reset Value	Description
31:0	RW	0000_0000h	Scratchpad Data (SKPD) 1 DWORD of data storage.

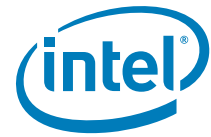

2.7.28 CAPIDO—Capability Identifier Register

This register is used to report various processor capabilities.

B/D/F/Type:		0/0/0/PCI	
Address Offset:		E0–EBh	
Reset Value:		SKU dependent	
Access:		RO	
Bit	Attr	Reset Value	Description
96:35	RO		Reserved
34:32	RO		DMFC: DDR3 Maximum Frequency Capability This field controls which values may be written to the Memory Frequency Select field 6:4 of the Clocking Configuration registers (MCHBAR Offset C00h). Any attempt to write an unsupported value will be ignored. 000 = GMCH capable of "All" memory frequencies 001 = Reserved 010 = Reserved 011 = Reserved 100 = Reserved 101 = GMCH capable of up to DDR3 1333 MHz 110 = GMCH capable of up to DDR3 1067 MHz 111 = Reserved
31:0	RO		Reserved

2.7.29 MCSAMPML—Memory Configuration, System Address Map and Pre-allocated Memory Lock Register

B/D/F/Type:		0/0/0/PCI	
Address Offset:		F4h	
Reset Value:		00h	
Access:		RW-O, RW-L, RW-L-K	
Bit	Attr	Reset Value	Description
7:5	RW-O	000b	Reserved
4	RW-L	0	Reserved
3	RW-L-K	0	Lock Mode (LOCKMODE) LOCKMODE and ME_SM_LOCK (bit 0) must always be programmed to the same value. See bit 0 for description details. 0 = Registers are not locked 1 = Registers are locked.
2	RW-L	0	Reserved
1	RO	0	Reserved
0	RW-L-K	0	ME Stolen Memory Lock (ME_SM_LOCK) When ME_SM_LOCK is set to 1, all registers related to MCH configuration become read only. BIOS will initialize configuration bits related to MCH configuration and then use ME_SM_lock to "lock down" the MCH configuration in the future so that no application software (or BIOS itself) can violate the integrity of DRAM - including ME stolen memory space. If BIOS writes this bit to 1, bit 3 "LOCKMODE" bit must also be written to 1 to ensure proper register lockdown. If BIOS writes this bit to 0, bit 3 "LOCKMODE" bit must also be written to 0. This bit and the LOCKMODE bit 3 should never be programmed differently. PCI device 0 and MCHBAR registers affected by this bit are detailed within the descriptions of the affected registers.



2.8 MCHBAR Registers

Table 2-5. MCHBAR Register Address Map (Sheet 1 of 2)

Address Offset	Register Symbol	Register Name	Reset Value	Access
111h	CHDECMISC	Channel Decode Misc	00h	RW-L, RO
200–201h	C0DRB0	Channel 0 DRAM Rank Boundary Address 0	0000h	RW-L, RO
202–203h	C0DRB1	Channel 0 DRAM Rank Boundary Address 1	0000h	RW-L, RO
204–205h	C0DRB2	Channel 0 DRAM Rank Boundary Address 2	0000h	RO, RW-L
206–207h	C0DRB3	Channel 0 DRAM Rank Boundary Address 3	0000h	RO, RW-L
208–209h	C0DRA01	Channel 0 DRAM Rank 0,1 Attribute	0000h	RW-L
20A–20Bh	C0DRA23	Channel 0 DRAM Rank 2,3 Attribute	0000h	RW-L
24D–24Fh	C0WRDATACTRL	Channel 0 Write Data Control	004111h	RW
250–251h	C0CYCTRKPCHG	Channel 0 CYCTRK PCHG	0000h	RO, RW
252–255h	C0CYCTRKACT	Channel 0 CYCTRK ACT	0000_0000h	RW, RO
256–257h	C0CYCTRKWR	Channel 0 CYCTRK WR	0000h	RW
258–25Ah	C0CYCTRKRD	Channel 0 CYCTRK READ	000000h	RO, RW
25B–25Ch	C0CYCTRKREFR	Channel 0 CYCTRK REFR	0000h	RO, RW
265–266h	C0PWLCTRL	Channel 0 PWLCTRL	0000h	RO, RW
269–26Eh	C0REFRCTRL	Channel 0 DRAM Refresh Control	241830000C30h	RW, RO
271h	COJEDEC	Channel 0 JEDEC CTRL	00h	RW, RO
298–29Bh	C0ODT	Channel 0 ODT Matrix	0000_0000h	RW, RO
29C–29Fh	C0ODTCTRL	Channel 0 ODT Control	0000_0000h	RW, RO
2B4–2B7h	C0DTC	Channel 0 DRAM Throttling Control	0000_0000h	RO, RW-L-K, RW-L
600–601h	C1DRB0	Channel 1 DRAM Rank Boundary Address 0	0000h	RW-L, RO
602–603h	C1DRB1	Channel 1 DRAM Rank Boundary Address 1	0000h	RO, RW-L
604–605h	C1DRB2	Channel 1 DRAM Rank Boundary Address 2	0000h	RW-L, RO
606–607h	C1DRB3	Channel 1 DRAM Rank Boundary Address 3	0000h	RW-L, RO
608–609h	C1DRA01	Channel 1 DRAM Rank 0,1 Attributes	0000h	RW-L
60A–60Bh	C1DRA23	Channel 1 DRAM Rank 2,3 Attributes	0000h	RW-L
64D–64Fh	C1WRDATACTRL	Channel 1 Write Data Control	004111h	RW
650–651h	C1CYCTRKPCHG	Channel 1 CYCTRK PCHG	0000h	RW, RO
652–655h	C1CYCTRKACT	Channel 1 CYCTRK ACT	0000_0000h	RW, RO
656–657h	C1CYCTRKWR	Channel 1 CYCTRK WR	0000h	RW
658–65Ah	C1CYCTRKRD	Channel 1 CYCTRK READ	000000h	RW, RO
660–663h	C1CKECTRL	Channel 1 CKE Control	0000_0800h	RW, RW-L, RO
69C–69Fh	C1ODTCTRL	Channel 1 ODT Control	0000_0000h	RO, RW
6A4–6A7h	C1GTC	Channel 1 Processor Throttling Control	0000_0000h	RW-L-K, RO, RW-L
6B4–6B7h	C1DTC	Channel 1 DRAM Throttling Control	0000_0000h	RO, RW-L-K, RW-L
C20–C27h	SSKPD	Sticky Scratchpad Data	0000_0000_0000_0000h	RW/P



Table 2-5. MCHBAR Register Address Map (Sheet 2 of 2)

Address Offset	Register Symbol	Register Name	Reset Value	Access
1001–1002h	TSC1	Thermal Sensor Control 1	0000h	RW-L, RO, RW, AF
1004–1005h	TSS1	Thermal Sensor Status 1	0000h	RO
1006h	TR1	Thermometer Read 1	FFh	RO
1007h	TOF1	Thermometer Offset 1	00h	RW
1008h	RTR1	Relative Thermometer Read 1	00h	RO
1010–1013h	TSTTPA1	Thermal Sensor Temperature Trip Point A1	0000_0000h	RW-L, RO
1014–1017h	TSTTPB1	Thermal Sensor Temperature Trip Point B1	0000_0000h	RW-L
1018–1019h	TS10BITMCTRL	Thermal Sensor 10-bit Mode Control	0000h	RW-L
101Ch	HWTHROTCTRL1	Hardware Throttle Control 1	00h	RW-L, RO, RW-O
101E–101Fh	TIS1	Thermal Interrupt Status 1	0000h	RO, RW1C
1070h	TERATE	Thermometer Mode Enable and Rate	00h	RO, RW
10E4h	TERRCMD	Thermal Error Command	00h	RO, RW
10E5h	TSMICMD	Thermal SMI Command	00h	RO, RW
10E6h	TSCICMD	Thermal SCI Command	00h	RW, RO
10E7h	TINTRCMD	Thermal INTR Command	00h	RO, RW
10EC–10EDh	EXTTSCS	External Thermal Sensor Control and Status	0000h	RO, RW-O, RW-L
1300–13FFh	RSVD	Reserved	0h	RO
2C20–2C22h	DDRMPLL1	DDR PLL BIOS	000000h	RO, RW



2.8.1 CSZMAP—Channel Size Mapping Register

This register indicates the total memory that is mapped to Interleaved and Asymmetric operation respectively (1 MB granularity) used for Channel address decode.

B/D/F/Type:		0/0/0/MCHBAR	
Address Offset:		100–107h	
Reset Value:		0000_0000_0000_0000h	
Access:		RW	
Bit	Attr	Reset Value	Description
63:48	RO	0h	Reserved
47:32	RW-L	0000h	2 Channel Size (2CHSZ) This register indicates the total memory that is mapped to 2-channel operation (1 MB granularity) This register is locked by ME pre-allocated Memory lock and may also be forced to 0000h by the Performance Dual Channel Disable fuse.
31:16	RW-L	0000h	1 Channel Size (1CHSZ) This register indicates the total memory that is mapped to 1-channel operation (1 MB granularity) This register is locked by ME pre-allocated Memory lock.
15:0	RW-L	0000h	Channel 0 Single Channel Size (C0SCSIZE) This register indicates the quantity of memory physically in channel 0 that is mapped to 1-channel operation (1 MB granularity).

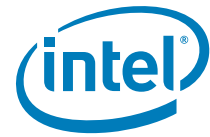

2.8.2 CHDECMISC—Channel Decode Miscellaneous Register

This register provides enhanced addressing configuration bits.

B/D/F/Type:		0/0/0/MCHBAR	
Address Offset:		111h	
Reset Value:		00h	
Access:		RW-L, RO	
BIOS Optimal Reset Value		0h	
Bit	Attr	Reset Value	Description
7	RW-L	0b	<p>Enhanced Address for DIMM Select (ENHDIMMSEL)</p> <p>This bit may only be set when enhanced mode of addressing for ranks is enabled (bit 6 is '0' and at least one of bit 3 or bit 2 are '1') and all four ranks are populated with equal amount of memory.</p> <p>0 = Use Standard methods for DIMM Select. 1 = Use Enhanced Address as DIMM Select.</p> <p>This register is locked by Memory pre-allocated for ME lock.</p>
6:5	RW-L	00b	<p>Enhanced Mode Select (ENHMODESEL)</p> <p>Enhanced Mode select applies only when enhanced addressing is enabled (at least one of bit 3 or bit 2 is '1').</p> <p>00 = Swap Enabled for Bank Selects and Rank Selects 01 = XOR Enabled for Bank Selects and Rank Selects 10 = Swap Enabled for Bank Selects only 11 = XOR Enabled for Bank Select only</p> <p>This register is locked by Memory pre allocated for MWlock.</p>
4	RO	0b	Reserved
3	RW-L	0b	<p>Channel 1 Enhanced Mode (CH1_ENHMODE)</p> <p>This bit indicates that enhanced addressing mode of operation is enabled for channel 1.</p> <p>Enhanced addressing mode of operation should be enabled only when both the channels are equally populated with same size and same type of DRAM memory.</p> <p>An added restriction is that the number of ranks/channel has to be 1, 2, or 4.</p> <p>Note: If any of the channels is in enhanced mode, the other channel should also be in enhanced mode.</p> <p>0 = Standard addressing 1 = Enhanced addressing</p> <p>This register is locked by Memory Pre-allocated for Graphics lock.</p>
2	RW-L	0b	<p>Channel 0 Enhanced Mode (CH0_ENHMODE)</p> <p>This bit indicates that enhanced addressing mode of operation is enabled for Channel 0.</p> <p>Enhanced addressing mode of operation should be enabled only when both the channels are equally populated with same size and same type of DRAM memory.</p> <p>An added restriction is that the number of ranks/channel has to be 1, 2 or 4.</p> <p>0 = Standard addressing 1 = Enhanced addressing</p> <p>Note: If any of the two channels is in enhanced mode, the other channel should also be in enhanced mode.</p> <p>This register is locked by Memory pre-allocated for MElock.</p>
1:0	RO	00b	Reserved



2.8.3 C0DRB0—Channel 0 DRAM Rank Boundary Address 0 Register

The DRAM Rank Boundary Registers define the upper boundary address of each DRAM rank with a granularity of 64 MB. Each rank has its own single-word DRB register. These registers are used to determine which chip select will be active for a given address. Channel and rank map:

ch0 rank0:	200h
ch0 rank1:	202h
ch0 rank2:	204h
ch0 rank3:	206h
ch1 rank0:	600h
ch1 rank1:	602h
ch1 rank2:	604h
ch1 rank3:	606h

Programming guide:

If Channel 0 is empty, all of the C0DRBs are programmed with 00h.

C0DRB0 = Total memory in ch0 rank0 (in 64 MB increments)

C0DRB1 = Total memory in ch0 rank0 + ch0 rank1 (in 64 MB increments)

and so on.

If Channel 1 is empty, all of the C1DRBs are programmed with 00h.

C1DRB0 = Total memory in ch1 rank0 (in 64 MB increments)

C1DRB1 = Total memory in ch1 rank0 + ch1 rank1 (in 64 MB increments) and so on.

B/D/F/Type:		0/0/0/MCHBAR	
Address Offset:		200–201h	
Reset Value:		0000h	
Access:		RW-L, RO	
Bit	Attr	Reset Value	Description
15:10	RO	00h	Reserved
9:0	RW-L	000h	Channel 0 DRAM Rank Boundary Address 0 (C0DRBA0) This register defines the DRAM rank boundary for rank0 of Channel 0 (64 MB granularity) =RO RO = Total rank0 memory size/64 MB R1 = Total rank1 memory size/64 MB R2 = Total rank2 memory size/64 MB R3 = Total rank3 memory size/64 MB This register is locked by Memory pre-allocated for ME lock.



2.8.4 CODRB1—Channel 0 DRAM Rank Boundary Address 1 Register

See CODRB0 register description for details.

B/D/F/Type:		0/0/0/MCHBAR	
Address Offset:		202–203h	
Reset Value:		0000h	
Access:		RW-L, RO	
Bit	Attr	Reset Value	Description
15:10	RO	00h	Reserved
9:0	RW-L	000h	Channel 0 DRAM Rank Boundary Address 1 (CODRBA1) This register defines the DRAM rank boundary for rank1 of Channel 0 (64 MB granularity) $= (R1 + R0)$ R0 = Total rank0 memory size/64 MB R1 = Total rank1 memory size/64 MB R2 = Total rank2 memory size/64 MB R3 = Total rank3 memory size/64 MB This register is locked by Memory pre-allocated for ME lock.

2.8.5 CODRB2—Channel 0 DRAM Rank Boundary Address 2 Register

See CODRB0 register description for details.

B/D/F/Type:		0/0/0/MCHBAR	
Address Offset:		204–205h	
Reset Value:		0000h	
Access:		RO, RW-L	
Bit	Attr	Reset Value	Description
15:10	RO	00h	Reserved
9:0	RW-L	000h	Channel 0 DRAM Rank Boundary Address 2 (CODRBA2) This register defines the DRAM rank boundary for rank2 of Channel 0 (64 MB granularity) $= (R2 + R1 + R0)$ R0 = Total rank0 memory size/64 MB R1 = Total rank1 memory size/64 MB R2 = Total rank2 memory size/64 MB R3 = Total rank3 memory size/64 MB This register is locked by Memory pre-allocated for ME lock.



2.8.6 C0DRB3—Channel 0 DRAM Rank Boundary Address 3 Register

See C0DRB0 register description for details.

B/D/F/Type:		0/0/0/MCHBAR	
Address Offset:		206–207h	
Reset Value:		0000h	
Access:		RO, RW-L	
Bit	Attr	Reset Value	Description
15:10	RO	00h	Reserved
9:0	RW-L	000h	Channel 0 DRAM Rank Boundary Address 3 (C0DRBA3) This register defines the DRAM rank boundary for rank3 of Channel 0 (64 MB granularity) $= (R3 + R2 + R1 + R0)$ R0 = Total rank0 memory size/64 MB R1 = Total rank1 memory size/64 MB R2 = Total rank2 memory size/64 MB R3 = Total rank3 memory size/64 MB This register is locked by Memory pre-allocated for MR lock.



2.8.7 CODRA01—Channel 0 DRAM Rank 0,1 Attribute Register

The DRAM Rank Attribute Registers define the page sizes/number of banks to be used when accessing different ranks. These registers should be left with their Reset Value (all zeros) for any rank that is unpopulated, as determined by the corresponding CxDRB registers. Each byte of information in the CxDRA registers describes the page size of a pair of ranks. Channel and rank map:

- Ch0 Rank0, 1: 208h–209h
- Ch0 Rank2, 3: 20Ah–20Bh
- Ch1 Rank0, 1: 608h–609h
- Ch1 Rank2, 3: 60Ah–60Bh

DRA[7:0] = "00" means cfg0, DRA[7:0] = "01" means cfg1....DRA[7:0] = "09" means cfg9 and so on.

Table 2-6. DRAM Rank Attribute Register Programming

DRA Config	Tech	Depth	Width	Row	Col	Bank	Rank Capacity	Page Size
00h through 83h	Reserved							
84h	512Mb	64M	8	13	10	3	512 MB	8K
85h	512Mb	32M	16	12	10	3	256 MB	8K
86h	1Gb	128M	8	14	10	3	1 GB	8K
87h	1Gb	64M	16	13	10	3	512MB	8K
88h	2Gb	256M	8	15	10	3	2 GB	8K
89h	2Gb	128M	16	14	10	3	1 GB	8K
8Ah	Reserved							
8Bh	4Gb	256M	16	15	10	3	2 GB	8K
8Ch through FFh	Reserved							

B/D/F/Type:		0/0/0/MCHBAR	
Address Offset:		208–209h	
Reset Value:		0000h	
Access:		RW-L	
Bit	Attr	Reset Value	Description
15:8	RW-L	00h	Channel 0 DRAM Rank-1 Attributes (CODRA1) This register defines DRAM page size/number-of-banks for rank 1 for given channel. See Table 2-6 for programming. This register is locked by Memory pre-allocated for MR lock.
7:0	RW-L	00h	Channel 0 DRAM Rank-0 Attributes (CODRA0) This register defines DRAM page size/number-of-banks for rank 0 for given channel. See Table 2-6 for programming. This register is locked by Memory pre-allocated for MRE lock.



2.8.8 CODRA23—Channel 0 DRAM Rank 2,3 Attribute Register

See CODRA01 register description for programming details.

B/D/F/Type:		0/0/0/MCHBAR	
Address Offset:		20A–20Bh	
Reset Value:		0000h	
Access:		RW-L	
Bit	Attr	Reset Value	Description
15:8	RW-L	00h	Channel 0 DRAM Rank-3 Attributes (CODRA3) This register defines DRAM page size/number-of-banks for rank 3 for given channel. This register is locked by Memory pre-allocated for ME lock.
7:0	RW-L	00h	Channel 0 DRAM Rank-2 Attributes (CODRA2) This register defines DRAM page size/number-of-banks for rank2 for given channel. This register is locked by Memory Pre-allocated for graphics lock.

2.8.9 COWRDATACTRL—Channel 0 Write Data Control Register

Channel 0 WR Data Control Registers.

B/D/F/Type:		0/0/0/MCHBAR	
Address Offset:		24D–24Fh	
Reset Value:		004111h	
Access:		RW	
BIOS Optimal Reset Value		00h	
Bit	Attr	Reset Value	Description
23:16	RW	00h	Reserved
15	RW	0b	Reserved
14:0	RW	4110h	Reserved

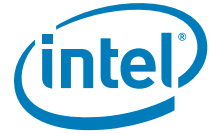

2.8.10 COCYCTRKPCHG—Channel 0 CYCTRK PCHG Register

B/D/F/Type:		0/0/0/MCHBAR	
Address Offset:		250-251h	
Reset Value:		0000h	
Access:		RO, RW	
Bit	Attr	Reset Value	Description
15:11	RO	00h	Reserved
10:6	RW	00h	Write To Precharge Delay (C0sd_cr_wr_pchg) This field indicates the minimum allowed spacing (in DRAM clocks) between the WRITE and PRE commands to the same rank-bank. This value corresponds to the tWR parameter in the DDR3 Specification.
5:2	RW	0h	Read To Precharge Delay (C0sd_cr_rd_pchg) This field indicates the minimum allowed spacing (in DRAM clocks) between the READ and PRE commands to the same rank-bank.
1:0	RW	00b	Precharge To Precharge Delay (C0sd_cr_pchg_pchg) This configuration register indicates the minimum allowed spacing (in DRAM clocks) between two PRE commands to the same rank.



2.8.11 COCYCTRKACT—Channel 0 CYCTRK ACT Register

B/D/F/Type:		0/0/0/MCHBAR	
Address Offset:		252–255h	
Reset Value:		0000_0000h	
Access:		RW, RO	
Bit	Attr	Reset Value	Description
31:30	RO	00b	Reserved
29	RW	0b	FAW Windowcnt Bug Fix Disable (FAWWBFD) This bit disables the CYCTRK FAW windowcnt bug fix. 1 = Disable CYCTRK FAW windowcnt bug fix 0 = Enable CYCTRK FAW windowcnt bug fix (C0sd_cr_cyctrk_faw_windowcnt_fix_disable)
28	RW	0b	FAW Phase Bug Fix Disable (FAWPBFD) This bit disables the CYCTRK FAW phase indicator bug fix. 1 = Disable CYCTRK FAW phase indicator bug fix 0 = Enable CYCTRK FAW phase indicator bug fix (C0sd_cr_cyctrk_faw_phase_fix_disable)
27:22	RW	00h	Activate Window Count (C0sd_cr_act_windowcnt) This field indicates the window duration (in DRAM clocks) during which the controller counts the number of activate commands which are launched to a particular rank. If the number of activate commands launched within this window is greater than 4, then a check is implemented to block launch of further activates to this rank for the rest of the duration of this window.
21	RW	0b	Max Activate Check (C0sd_cr_maxact_dischk) This bit enables the check which ensures that there are no more than four activates to a particular rank in a given window.
20:17	RW	0h	Activate to Activate Delay (C0sd_cr_act_act) This field indicates the minimum allowed spacing (in DRAM clocks) between two ACT commands to the same rank. This value corresponds to the tRRD parameter in the DDR3 specification.
16:13	RW	0h	Precharge to Activate Delay (C0sd_cr_pre_act) This configuration register indicates the minimum allowed spacing (in DRAM clocks) between the PRE and ACT commands to the same rank-bank. This value corresponds to the tRP parameter in the DDR3 specification.
12:9	RW	0h	Precharge All to Activate Delay (C0sd_cr_preall_act) From the launch of a precharge-all command wait for this many memory bus clocks before launching an activate command. This value corresponds to the tPALL_RP parameter.
8:0	RW	000h	Refresh to Activate Delay (C0sd_cr_rfsh_act) This configuration register indicates the minimum allowed spacing (in DRAM clocks) between REF and ACT commands to the same rank. This value corresponds to the tRFC parameter in the DDR3 specification.



2.8.12 COCYCTRKWR—Channel 0 CYCTRK WR Register

B/D/F/Type:		0/0/0/MCHBAR	
Address Offset:		256–257h	
Reset Value:		0000h	
Access:		RW	
Bit	Attr	Reset Value	Description
15:12	RW	0h	Activate To Write Delay (C0sd_cr_act_wr) This field indicates the minimum allowed spacing (in DRAM clocks) between the ACT and WRITE commands to the same rank-bank. This value corresponds to the tRCD_wr parameter in the DDR3 specification.
11:8	RW	0h	Same Rank Write To Write Delay (C0sd_cr_wrsr_wr) This field indicates the minimum allowed spacing (in DRAM clocks) between two WRITE commands to the same rank.
7:4	RW	0h	Different Rank Write to Write Delay (C0sd_cr_wrdr_wr) This field indicates the minimum allowed spacing (in DRAM clocks) between two WRITE commands to different ranks. This value corresponds to the tWR_WR parameter in the DDR3 specification.
3:0	RW	0h	Read To Write Delay (C0sd_cr_rd_wr) This field indicates the minimum allowed spacing (in DRAM clocks) between the READ and WRITE commands. This value corresponds to the tRD_WR parameter.

2.8.13 COCYCTRKR—Channel 0 CYCTRK READ Register

B/D/F/Type:		0/0/0/MCHBAR	
Address Offset:		258–25Ah	
Reset Value:		000000h	
Access:		RO, RW	
Bit	Attr	Reset Value	Description
23:21	RO	000b	Reserved
20:17	RW	0h	Minimum Activate To Read Delay (C0sd_cr_act_rd) This field indicates the minimum allowed spacing (in DRAM clocks) between the ACT and READ commands to the same rank-bank. This value corresponds to tRCD_rd parameter in the DDR3 specification.
16:12	RW	00h	Same Rank Write To Read Delayed (C0sd_cr_wrsr_rd) This field indicates the minimum allowed spacing (in DRAM clocks) between the WRITE and READ commands to the same rank. This value corresponds to the tWTR parameter in the DDR3 specification.
11:8	RW	0h	Different Ranks Write To Read Delayed (C0sd_cr_wrdr_rd) This field indicates the minimum allowed spacing (in DRAM clocks) between the WRITE and READ commands to different ranks. This value corresponds to the tWR_RD parameter in the DDR3 specification.
7:4	RW	0h	Same Rank Read To Read Delayed (C0sd_cr_rdsr_rd) This field indicates the minimum allowed spacing (in DRAM clocks) between two READ commands to the same rank.
3:0	RW	0h	Different Ranks Read To Read Delayed (C0sd_cr_rddr_rd) This field indicates the minimum allowed spacing (in DRAM clocks) between two READ commands to different ranks. This value corresponds to the tRD_RD parameter.



2.8.14 COCYCTRKREFR—Channel 0 CYCTRK REFR Register

This register provides Channel 0 CYCTRK Refresh control.

B/D/F/Type:		0/0/0/MCHBAR	
Address Offset:		25B–25Ch	
Reset Value:		0000h	
Access:		RO, RW	
Bit	Attr	Reset Value	Description
15:13	RO	000b	Reserved
12:9	RW	0h	Same Rank Precharge All to Refresh Delay (C0sd_cr_pchgall_rfsh) This field indicates the minimum allowed spacing (in DRAM clocks) between the PRE-ALL and REF commands to the same rank.
8:0	RW	000h	Same Rank Refresh to Refresh Delay (C0sd_cr_rfsh_rfsh) This field indicates the minimum allowed spacing (in DRAM clocks) between two REF commands to the same rank.

2.8.15 COPWLRCTRL—Channel 0 Partial Write Line Read Control Register

This register configures the DRAM controller partial write policies.

B/D/F/Type:		0/0/0/MCHBAR	
Address Offset:		265–266h	
Reset Value:		0000h	
Access:		RW, RO	
Bit	Attr	Reset Value	Description
15:14	RO	00b	Reserved
13:8	RW	00h	Read And Merging-write Window (C0sd_cr_rdmowr_window) This configuration setting defines the time period (in mclks) between the read and the merging-write commands on the DRAM bus. This window duration is a function of the tRD and write data latency through the chipset.
7:5	RO	000b	Reserved
4:0	RW	00h	Partial Write Trip Threshold (PWTRIP) This configuration setting indicates the threshold for number of partial writes which are blocked from arbitration before indicating a trip.



2.8.16 COREFRCTRL—Channel 0 DRAM Refresh Control Register

This register provides settings to configure the DRAM refresh controller.

B/D/F/Type:		0/0/0/MCHBAR	
Address Offset:		269–26Eh	
Reset Value:		24183000C30h	
Access:		RW, RO	
Bit	Attr	Reset Value	Description
47	RO	0b	Reserved
46:44	RW	010b	Initial Refresh Count (INITREFCNT) Initial Refresh Count Value.
43:38	RW	10h	Direct Rcomp Quiet Window (DIRQUIET) This configuration setting indicates the amount of refresh_tick events to wait before the service of rcomp request in non-default mode of independent rank refresh.
37:32	RW	18h	Indirect Rcomp Quiet Window (INDIRQUIET) This configuration setting indicates the amount of refresh_tick events to wait before the service of rcomp request in non-default mode of independent rank refresh.
31:27	RW	06h	Rcomp Wait (RCOMPWAIT) This configuration setting indicates the amount of refresh_tick events to wait before the service of rcomp request in non-default mode of independent rank refresh.
26	RW	0b	ZQCAL Enable (ZQCALEN) This bit enables the DRAM controller to issue ZQCAL commands periodically.
25	RW	0b	Refresh Counter Enable (REFCNTEN) This bit is used to enable the refresh counter to count during times that DRAM is not in self-refresh, but refreshes are not enabled. Such a condition may occur due to need to reprogram the DIMMs following a DRAM controller switch. This bit has no effect when Refresh is enabled (that is, there is no mode where Refresh is enabled but the counter does not run) so, in conjunction with bit 23 REFEN, the modes are: REFEN:REFCNTEN Description 0:0 Normal refresh disable 0:1 Refresh disabled, but counter is accumulating refreshes. 1:X Normal refresh enable
24	RW	0b	All Rank Refresh (ALLRKREF) This configuration bit enables (by default) that all the ranks are refreshed in a staggered/atomic fashion. If set, the ranks are refreshed in an independent fashion. 0 = Ranks are refreshed atomically staggered 1 = Ranks are refreshed independently
23	RW	0b	Refresh Enable (REFEN) 0 = Disabled 1 = Enabled
22	RW	0b	DDR Initialization Done (INITDONE) Indicates that DDR initialization is complete.



B/D/F/Type:		0/0/0/MCHBAR	
Address Offset:		269–26Eh	
Reset Value:		24183000C30h	
Access:		RW, RO	
Bit	Attr	Reset Value	Description
21:20	RW	00b	DRAM Refresh Hysterisis (REFHYSTERISIS) Hysterisis level — useful for dref_high watermark cases. The dref_high flag is set when the dref_high watermark level is exceeded, and is cleared when the refresh count is less than the hysterisis level. This bit should be set to a value less than the high watermark level. 00 = 3 01 = 4 10 = 5 11 = 6
19:18	RW	00b	DRAM Refresh Panic Watermark (REFPANICWM) When the refresh count exceeds this level, a refresh request is launched to the scheduler and the dref_panic flag is set. 00 = 5 01 = 6 10 = 7 11 = 8
17:16	RW	00b	DRAM Refresh High Watermark (REFHIGHWM) When the refresh count exceeds this level, a refresh request is launched to the scheduler and the dref_high flag is set. 00 = 3 01 = 4 10 = 5 11 = 6
15:14	RW	00b	DRAM Refresh Low Watermark (REFLOWWM) When the refresh count exceeds this level, a refresh request is launched to the scheduler and the dref_low flag is set. 00 = 1 01 = 2 10 = 3 11 = 4
13:0	RW	0C30h	Refresh Counter Time Out Value (REFTIMEOUT) Program this field with a value that will provide 7.8 us at mb4clk frequency. At various mb4clk frequencies this results in the following values: 266 MHz -> 820 hex 333 MHz -> A28 hex 400 MHz -> C30 hex 533 MHz -> 1040 hex 666 MHz -> 1450 hex



2.8.17 COJEDEC—Channel 0 JEDEC Control Register

This is the Channel 0 JEDEC Control Register.

B/D/F/Type:		0/0/0/MCHBAR	
Address Offset:		271h	
Reset Value:		00h	
Access:		RW, RO	
Bit	Attr	Reset Value	Description
7	RW	0b	Functional Loopback Mode Enable (FLME) This configuration setting indicates that the chip is placed in FME (Functional Loopback Mode Enable) mode.
6	RW	0b	Write Levelization Mode (WRLVLMDE) This configuration bit indicates that memory controller is in write levelization mode.
5:4	RW	00b	EMRS Mode (sd0_cr_emrs_mode) This configuration field indicates the type of the EMRS command being issued as a part of the JEDEC initialization. 00 = no EMRS command 01 = EMRS 10 = EMRS2 11 = EMRS3
3:1	RW	000b	Mode Select (sd0_cr_sms) This configuration setting indicates the mode in which the controller is operating. 000 = Post Reset state 001 = NOP Command Enable 010 = All Banks Pre-charge Enable 011 = Mode Register Set Enable 100 = Extended Mode Register Set Enable 101 = Reserved 110 = CBR Refresh Enable 111 = Normal mode of operation.
0	RO	0b	Reserved



2.8.18 C0ODT—Channel 0 ODT Matrix Register

This is an ODT related configuration register. It is BIOS responsibility to program these bits to turn on/off the DRAM ODT signals according to how the system is populated; that is, 2r/2r, 2r/1r, 1r/2r, 1r/1r, 2r/nc, nc/2r, 1r/nc, nc/1r. This software approach has the benefit of simplifying the hardware, helping PV and increasing greater flexibility in ODT choices (especially when multiple ODT are required to be turned on).

B/D/F/Type:		0/0/0/MCHBAR	
Address Offset:		298–29Bh	
Reset Value:		0000_0000h	
Access:		RW, RO	
Bit	Attr	Reset Value	Description
31:20	RO	000h	Reserved
19	RW	0b	DODTAO3 (sd0_cr_dodtao_r3) Force DRAM ODT Always ON for rank3. 1 = ON 0 = OFF (except during self refresh commands).
18	RW	0b	DODTAO2 (sd0_cr_dodtao_r2) Force DRAM ODT Always ON for rank2. 1 = ON 0 = OFF (except during self refresh commands).
17	RW	0b	DODTAO1 (sd0_cr_dodtao_r1) Force DRAM ODT Always ON for rank1. 1 = ON 0 = OFF (except during self refresh commands).
16	RW	0b	DODTAO0 (sd0_cr_dodtao_r0) Force DRAM ODT Always ON for rank0. 1 = ON 0 = OFF (except during self refresh commands).
15	RW	0b	DODTRD1R3 (sd0_cr_rdrank1_r3odt) Assert rank3 ODT during Reads from RANK1. 1 = ON 0 = OFF
14	RW	0b	DODTRD1R2 (sd0_cr_rdrank1_r2odt) Assert rank2 ODT during Reads from RANK1. 1 = ON 0 = OFF
13	RW	0b	DODTRD1R1 (sd0_cr_rdrank1_r1odt) Assert rank1 ODT during Reads from RANK1. 1 = ON 0 = OFF
12	RW	0b	DODTRD1R0 (sd0_cr_rdrank1_r0odt) Assert rank0 ODT during Reads from RANK1. 1 = ON 0 = OFF
11	RW	0b	DODTRDOR3 (sd0_cr_rdrank0_r3odt) Assert rank3 ODT during Reads from RANK0. 1 = ON 0 = OFF
10	RW	0b	DODTRDOR2 (sd0_cr_rdrank0_r2odt) Assert rank2 ODT during Reads from RANK0. 1 = ON 0 = OFF



B/D/F/Type:		0/0/0/MCHBAR	
Address Offset:		298–29Bh	
Reset Value:		0000_0000h	
Access:		RW, RO	
Bit	Attr	Reset Value	Description
9	RW	0b	DODTRDOR1 (sd0_cr_rdrank0_r1odt) Assert rank1 ODT during Reads from RANK0. 1 = ON 0 = OFF
8	RW	0b	DODTRDOR0 (sd0_cr_rdrank0_r0odt) Assert rank0 ODT during Reads from RANK0. 1 = ON 0 = OFF
7	RW	0b	DODTWR1R3 (sd0_cr_wrrank1_r3odt) Assert rank3 ODT during Writes to RANK1. 1 = ON 0 = OFF
6	RW	0b	DODTWR1R2 (sd0_cr_wrrank1_r2odt) Assert rank2 ODT during Writes to RANK1. 1 = ON 0 = OFF
5	RW	0b	DODTWR1R1 (sd0_cr_wrrank1_r1odt) Assert rank1 ODT during Writes to RANK1. 1 = ON 0 = OFF
4	RW	0b	DODTWR1R0 (sd0_cr_wrrank1_r0odt) Assert rank0 ODT during Writes to RANK1. 1 = ON 0 = OFF
3	RW	0b	DODTWR0R3 (sd0_cr_wrrank0_r3odt) Assert rank3 ODT during Writes to RANK0. 1 = ON 0 = OFF
2	RW	0b	DODTWR0R2 (sd0_cr_wrrank0_r2odt) Assert rank2 ODT during Writes to RANK0. 1 = ON 0 = OFF
1	RW	0b	DODTWR0R1 (sd0_cr_wrrank0_r1odt) Assert rank1 ODT during Writes to RANK0. 1 = ON
0	RW	0b	DODTWR0R0 (sd0_cr_wrrank0_r0odt) Assert rank0 ODT during Writes to RANK0. 1 = ON 0 = OFF



2.8.19 COODTCTRL—Channel 0 ODT Control Register

B/D/F/Type:		0/0/0/MCHBAR	
Address Offset:		29C–29Fh	
Reset Value:		0000_0000h	
Access:		RW, RO	
Bit	Attr	Reset Value	Description
31:12	RO	00000h	Reserved
11:8	RW	0h	DRAM ODT for Read Commands (sd0_cr_odt_duration_rd) Specifies the duration in mb2clks to assert DRAM ODT for Read Commands. The Async value should be used when the Dynamic Powerdown bit is set. Otherwise, use the Sync value.
7:4	RW	0h	DRAM ODT for Write Commands (sd0_cr_odt_duration_wr) Specifies the duration in mb2clks to assert DRAM ODT for Write Commands. The Async value should be used when the Dynamic Powerdown bit is set. Otherwise, use the Sync value.
3:0	RW	0h	MCH ODT for Read Commands (sd0_cr_mchodt_duration) This field specifies the duration in mb2clks to assert MCH ODT for Read Commands.

2.8.20 CODTC—Channel 0 DRAM Throttling Control Register

Programmable Event weights are input into the averaging filter. Each Event weight is a normalized 8 bit value that the BIOS must program. The BIOS must account for burst length and 1N/2N rule considerations. It is also possible for BIOS to take into account loading variations of memory caused as a function of memory types and population of ranks.

B/D/F/Type:		0/0/0/MCHBAR	
Address Offset:		2B4–2B7h	
Reset Value:		0000_0000h	
Access:		RO, RW-L-K, RW-L	
Bit	Attr	Reset Value	Description
31:24	RO	00h	Reserved
23	RW-L-K	0b	DRAM Throttle Lock (DTLOCK) This bit secures the DRAM throttling control registers DT*EW and DTC. Once a 1 is written to this bit, all of these configuration register bits become read-only.
22:22	RO	0h	Reserved
21	RW-L	0b	DRAM Bandwidth Based Throttling Enable (DBBTE) 0 = Bandwidth Threshold (WAB) is not used for throttling. 1 = Bandwidth Threshold (WAB) is used for throttling. If both Bandwidth based and thermal sensor based throttling modes are on and the thermal sensor trips, weighted average WAT is used for throttling.
20	RW-L	0b	DRAM Thermal Sensor Trip Enable (DTSTE) 0 = GMCH throttling is not initiated when the GMCH thermal sensor trips. 1 = GMCH throttling is initiated when the GMCH thermal sensor trips and the Filter output is equal to or exceeds thermal threshold WAT.
19	RO	0b	Reserved



B/D/F/Type:		0/0/0/MCHBAR	
Address Offset:		2B4–2B7h	
Reset Value:		0000_0000h	
Access:		RO, RW-L-K, RW-L	
Bit	Attr	Reset Value	Description
18:16	RW-L	000b	Time Constant (TC) 000 = 2 ²⁸ Clocks 001 = 2 ²⁹ Clocks 010 = 2 ³⁰ Clocks 011 = 2 ³¹ Clocks Others = Reserved
15:8	RW-L	00h	Weighted Average Bandwidth Limit (WAB) Average weighted bandwidth allowed per clock during bandwidth based throttling. The processor does not allow any transactions to proceed on the System Memory bus if the output of the filter equals or exceeds this value.
7:0	RW-L	00h	Weighted Average Thermal Limit (WAT) Average weighted bandwidth allowed per clock during for thermal sensor enabled throttling. The processor does not allow any transactions to proceed on the System Memory bus if the output of the filter equals or exceeds this value.

2.8.21 CORSTCTL—Channel 0 Reset Controls Register

This register contains all the reset controls for the DDR IO buffers.

B/D/F/Type:		0/0/0/MCHBAR	
Address Offset:		5D8h	
Reset Value:		0Eh	
Access:		RW/P, RO	
Bit	Attr	Reset Value	Description
7:1	RO	00h	Reserved
0	RW-S	0b	DRAM IO Buffers Activate (IOBUFACT) This bit controls BOTH channels. This bit is cleared to 0 during reset and remains inactive (even after reset de-asserts) until it is set to 1 by BIOS. If at any time this bit is cleared, both channels' IO buffers will be put into their reset state. 0 = All DDR IO buffers are put into reset state 1 = All DDR IO buffers are out of reset and in normal operation mode



2.8.22 C1DRB0—Channel 1 DRAM Rank Boundary Address 0 Register

The operation of this register is detailed in the description for register C0DRB0.

B/D/F/Type:		0/0/0/MCHBAR	
Address Offset:		600–601h	
Reset Value:		0000h	
Access:		RW-L, RO	
Bit	Attr	Reset Value	Description
15:10	RO	000000b	Reserved
9:0	RW-L	000h	Channel 1 DRAM Rank Boundary Address 0 (C1DRBA0) See C0DRB0 register description. This register is locked by Memory pre-allocated for ME lock.

2.8.23 C1DRB1—Channel 1 DRAM Rank Boundary Address 1 Register

The operation of this register is detailed in the description for register C0DRB0.

B/D/F/Type:		0/0/0/MCHBAR	
Address Offset:		602–603h	
Reset Value:		0000h	
Access:		RO, RW-L	
Bit	Attr	Reset Value	Description
15:10	RO	000000b	Reserved
9:0	RW-L	000h	Channel 1 DRAM Rank Boundary Address 1 (C1DRBA1) See C0DRB1 register description. This register is locked by Memory pre-allocated for ME lock.

2.8.24 C1DRB2—Channel 1 DRAM Rank Boundary Address 2 Register

The operation of this register is detailed in the description for register C0DRB0.

B/D/F/Type:		0/0/0/MCHBAR	
Address Offset:		604–605h	
Reset Value:		0000h	
Access:		RW-L, RO	
Bit	Attr	Reset Value	Description
15:10	RO	000000b	Reserved
9:0	RW-L	000h	Channel 1 DRAM Rank Boundary Address 2 (C1DRBA2) See C0DRB2 register description. This register is locked by Memory pre-allocated for ME lock.

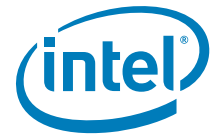

2.8.25 C1DRB3—Channel 1 DRAM Rank Boundary Address 3 Register

The operation of this register is detailed in the description for register CODRBO.

B/D/F/Type:		0/0/0/MCHBAR	
Address Offset:		606–607h	
Reset Value:		0000h	
Access:		RW-L, RO	
Bit	Attr	Reset Value	Description
15:10	RO	000000b	Reserved
9:0	RW-L	000h	Channel 1 DRAM Rank Boundary Address 3 (C1DRBA3) See CODRB3 register description. This register is locked by Memory pre-allocated for ME lock.

2.8.26 C1DRA01—Channel 1 DRAM Rank 0,1 Attributes Register

The operation of this register is detailed in the description for register CODRA01.

B/D/F/Type:		0/0/0/MCHBAR	
Address Offset:		608–609h	
Reset Value:		0000h	
Access:		RW-L	
Bit	Attr	Reset Value	Description
15:8	RW-L	00h	Channel 1 DRAM Rank-1 Attributes (C1DRA1) See CODRA1 register description. This register is locked by Memory pre-allocated for ME lock.
7:0	RW-L	00h	Channel 1 DRAM Rank-0 Attributes (C1DRA0) See CODRA0 register description. This register is locked by Memory pre-allocated for ME lock.

2.8.27 C1DRA23—Channel 1 DRAM Rank 2, 3 Attributes Register

The operation of this register is detailed in the description for register CODRA01.

B/D/F/Type:		0/0/0/MCHBAR	
Address Offset:		60A–60Bh	
Reset Value:		0000h	
Access:		RW-L	
Bit	Attr	Reset Value	Description
15:8	RW-L	00h	Channel 1 DRAM Rank-3 Attributes (C1DRA3) See CODRA3 register description. This register is locked by Memory pre-allocated for ME lock.
7:0	RW-L	00h	Channel 1 DRAM Rank-2 Attributes (C1DRA2) See CODRA2 register description. This register is locked by Memory pre-allocated for ME lock.



2.8.28 C1WRDATACTRL—Channel 1 Write Data Control Register

This register provides Channel 1 Write Data Control.

B/D/F/Type:		0/0/0/MCHBAR	
Address Offset:		64D–64Fh	
Reset Value:		004111h	
Access:		RW	
BIOS Optimal Reset Value		00h	
Bit	Attr	Reset Value	Description
23:16	RW	00h	Reserved
15	RW	0b	Reserved
14:0	RW	4110h	Reserved (sd1_cr_wrblk_wriodlldur) There is a legacy signal connected to this register that attaches to logic, but the output of that logic does not connect to any functionality.

2.8.29 C1CYCTRKPCHG—Channel 1 CYCTRK PCHG Register

This register provides Channel 1 CYCTRK Precharge control.

B/D/F/Type:		0/0/0/MCHBAR	
Address Offset:		650–651h	
Reset Value:		0000h	
Access:		RW, RO	
Bit	Attr	Reset Value	Description
15:11	RO	00000b	Reserved
10:6	RW	00000b	Write To PRE Delayed (C1sd_cr_wr_pchg) This field indicates the minimum allowed spacing (in DRAM clocks) between the WRITE and PRE commands to the same rank-bank. This field corresponds to tWR in the DDR Specification.
5:2	RW	0000b	READ To PRE Delayed (C1sd_cr_rd_pchg) This field indicates the minimum allowed spacing (in DRAM clocks) between the READ and PRE commands to the same rank-bank.
1:0	RW	00b	PRE To PRE Delayed (C1sd_cr_pchg_pchg) This field indicates the minimum allowed spacing (in DRAM clocks) between two PRE commands to the same rank.



2.8.30 C1CYCTRKACT—Channel 1 CYCTRK ACT Register

This register provides Channel 1 CYCTRK ACT control.

B/D/F/Type:		0/0/0/MCHBAR	
Address Offset:		652–655h	
Reset Value:		0000_0000h	
Access:		RW, RO	
Bit	Attr	Reset Value	Description
31:30	RO	0h	Reserved
29	RW	0b	FAW Windowcnt Bug Fix Disable (FAWWBFD) This bit disables the CYCTRK FAW windowcnt bug fix. 1 = Disable CYCTRK FAW windowcnt bug fix 0 = Enable CYCTRK FAW windowcnt bug fix (C1sd_cr_cyctrk_faw_windowcnt_fix_disable)
28	RW	0b	FAW Phase Bug Fix Disable (FAWPBFD) This bit disables the CYCTRK FAW phase indicator bug fix. 1 = Disable CYCTRK FAW phase indicator bug fix 0 = Enable CYCTRK FAW phase indicator bug fix (C1sd_cr_cyctrk_faw_phase_fix_disable)
27:22	RW	000000b	ACT Window Count (C1sd_cr_act_windowcnt) This field indicates the window duration (in DRAM clocks) during which the controller counts the number of activate commands which are launched to a particular rank. If the number of activate commands launched within this window is greater than 4, then a check is implemented to block launch of further activates to this rank for the rest of the duration of this window.
21	RW	0b	Max ACT Check (C1sd_cr_maxact_dischk) This bit enables the check which ensures that there are no more than four activates to a particular rank in a given window.
20:17	RW	0000b	ACT to ACT Delayed (C1sd_cr_act_act) This field indicates the minimum allowed spacing (in DRAM clocks) between two ACT commands to the same rank. This field corresponds to tRRD in the DDR specification.
16:13	RW	0000b	PRE to ACT Delayed (C1sd_cr_pre_act) This field indicates the minimum allowed spacing (in DRAM clocks) between the PRE and ACT commands to the same rank-bank: 12:9R/W0000bPRE-ALL to ACT Delayed (C1sd_cr_preall_act): This field indicates the minimum allowed spacing (in DRAM clocks) between the PRE-ALL and ACT commands to the same rank. This field corresponds to tRP in the DDR specification.
12:9	RW	0h	ALLPRE to ACT Delay (C1sd_cr_preall_act) From the launch of a prechargeall command wait for these many numbers of mclks before launching a activate command. Corresponds to tPALL_RP.
8:0	RW	00000000 0b	REF to ACT Delayed (C1sd_cr_rfsh_act) This field indicates the minimum allowed spacing (in DRAM clocks) between REF and ACT commands to the same rank. This field corresponds to tRFC in the DDR specification.



2.8.31 C1CYCTRKWR—Channel 1 CYCTRK WR Register

This register provides Channel 1 CYCTRK WR control.

B/D/F/Type:		0/0/0/MCHBAR	
Address Offset:		656–657h	
Reset Value:		0000h	
Access:		RW	
Bit	Attr	Reset Value	Description
15:12	RW	0h	ACT To Write Delay (C1sd_cr_act_wr) This field indicates the minimum allowed spacing (in DRAM clocks) between the ACT and WRITE commands to the same rank-bank. This field corresponds to tRCD_wr in the DDR specification.
11:8	RW	0h	Same Rank Write To Write Delayed (C1sd_cr_wrsr_wr) This field indicates the minimum allowed spacing (in DRAM clocks) between two WRITE commands to the same rank.
7:4	RW	0h	Different Rank Write to Write Delay (C1sd_cr_wrdr_wr) This field indicates the minimum allowed spacing (in DRAM clocks) between two WRITE commands to different ranks. This field corresponds to tWR_WR in the DDR specification.
3:0	RW	0h	READ To WRTE Delay (C1sd_cr_rd_wr) This field indicates the minimum allowed spacing (in DRAM clocks) between the READ and WRITE commands. This field corresponds to tRD_WR.

2.8.32 C1CYCTRKRd—Channel 1 CYCTRK READ Register

This register is for Channel 1 CYCTRK READ control.

B/D/F/Type:		0/0/0/MCHBAR	
Address Offset:		658–65Ah	
Reset Value:		000000h	
Access:		RW, RO	
Bit	Attr	Reset Value	Description
23:21	RO	0h	Reserved
20:17	RW	0h	Min ACT To READ Delayed (C1sd_cr_act_rd) This field indicates the minimum allowed spacing (in DRAM clocks) between the ACT and READ commands to the same rank-bank. This field corresponds to tRCD_rd in the DDR specification.
16:12	RW	00000b	Same Rank Write To READ Delayed (C1sd_cr_wrsr_rd) This field indicates the minimum allowed spacing (in DRAM clocks) between the WRITE and READ commands to the same rank. This field corresponds to tWTR in the DDR specification.
11:8	RW	0000b	Different Ranks Write To READ Delayed (C1sd_cr_wrdr_rd) This field indicates the minimum allowed spacing (in DRAM clocks) between the WRITE and READ commands to different ranks. This field corresponds to tWR_RD in the DDR specification.
7:4	RW	0000b	Same Rank Read To Read Delayed (C1sd_cr_rdsr_rd) This field indicates the minimum allowed spacing (in DRAM clocks) between two READ commands to the same rank.
3:0	RW	0000b	Different Ranks Read To Read Delayed (C1sd_cr_rddr_rd) This field indicates the minimum allowed spacing (in DRAM clocks) between two READ commands to different ranks. This field corresponds to tRD_RD.



2.8.33 C1CKECTRL—Channel 1 CKE Control Register

This register provides Channel 1 CKE Control.

B/D/F/Type:		0/0/0/MCHBAR	
Address Offset:		660–663h	
Reset Value:		0000_0800h	
Access:		RW, RW-L, RO	
Bit	Attr	Reset Value	Description
31:28	RO	0h	Reserved
27	RW	0b	start the self-refresh exit sequence (sd1_cr_srcstart) This bit indicates the request to start the self-refresh exit sequence.
26:24	RW	000b	CKE pulse width requirement in high phase (sd1_cr_cke_pw_hl_safe) This field indicates CKE pulse width requirement in high phase. The field corresponds to tCKE (high) in the DDR specification.
23	RW-L	0b	Rank 3 Population (sd1_cr_rankpop3) 1 = Rank 3 populated 0 = Rank 3 not populated. This register is locked by ME pre-allocated Memory lock.
22	RW-L	0b	Rank 2 Population (sd1_cr_rankpop2) 1 = Rank 2 populated 0 = Rank 2 not populated This register is locked by ME pre-allocated Memory lock.
21	RW-L	0b	Rank 1 Population (sd1_cr_rankpop1) 1 = Rank 1 populated 0 = Rank 1 not populated This register is locked by ME pre-allocated Memory lock.
20	RW-L	0b	Rank 0 Population (sd1_cr_rankpop0) 1 = Rank 0 populated 0 = Rank 0 not populated This register is locked by ME pre-allocated Memory lock.
19:17	RW	000b	CKE pulse width requirement in low phase (sd1_cr_cke_pw_lh_safe) This field indicates CKE pulse width requirement in low phase. The field corresponds to tCKE (low) in the DDR Specification.
16:14	RO	000b	Reserved
13:10	RW	0010b	Minimum Powerdown Exit to Non-Read command spacing (sd1_cr_txp) This field indicates the minimum number of clocks to wait following assertion of CKE before issuing a non-read command. 1010-1111 = Reserved 0010-1001 = 2-9 clocks 0000-0001 = Reserved.
9:1	RW	00000000 0b	Self refresh exit count (sd1_cr_slfrfsh_exit_cnt) This field indicates the Self refresh exit count. (Program to 255). This field corresponds to tXSNR/tXSRD in the DDR specification.
0	RW	0b	This bit indicates only 1 DIMM populated (sd1_cr_singledimmpop) This configuration register indicates that only 1 DIMM is populated.



2.8.34 C1PWLCTRL—Channel 1 Partial Write Line Read Control Register

This register is to configure the DRAM controller's partial write policies.

B/D/F/Type:		0/0/0/MCHBAR	
Address Offset:		665–666h	
Reset Value:		0000h	
Access:		RW, RO	
Bit	Attr	Reset Value	Description
15:14	RO	00b	Reserved
13:8	RW	000000b	Read And Merging-write Window (C1sd_cr_rdmowr_window) This configuration setting defines the time period (in mclks) between the read and the merging-write commands on the DRAM bus. This window duration is a function of the tRD and write data latency through the chipset.
7:5	RO	000b	Reserved
4:0	RW	00000b	Partial Write Trip Threshold (PWTRIP) This configuration setting indicates the threshold for number of partial writes which are blocked from arbitration before indicating a trip.

2.8.35 C1ODTCTRL—Channel 1 ODT Control Register

This register provides ODT controls.

B/D/F/Type:		0/0/0/MCHBAR	
Address Offset:		69C–69Fh	
Reset Value:		0000_0000h	
Access:		RO, RW	
Bit	Attr	Reset Value	Description
31:12	RO	00000h	Reserved
11:8	RW	0h	DRAM ODT for Read Commands (sd1_cr_odt_duration_rd) This field specifies the duration in DRAM bus clocks to assert DRAM ODT for Read Commands. The Async value should be used when the Dynamic Powerdown bit is set. Otherwise, use the Sync value.
7:4	RW	0h	DRAM ODT for Write Commands (sd1_cr_odt_duration_wr) This field specifies the duration in DRAM bus clocks to assert DRAM ODT for Write Commands. The Async value should be used when the Dynamic Powerdown bit is set. Otherwise, use the Sync value.
3:0	RW	0h	MCH ODT for Read Commands (sd1_cr_mchodt_duration) This field specifies the duration in DRAM bus clocks to assert MCH ODT for Read Commands.

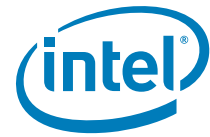

2.8.36 C1DTC—Channel 1 DRAM Throttling Control Register

Programmable Event weights are input into the averaging filter. Each Event weight is a normalized 8 bit value that the BIOS must program. The BIOS must account for burst length and 1N/2N rule considerations. It is also possible for BIOS to take into account loading variations of memory caused as a function of memory types and population of ranks.

B/D/F/Type:		0/0/0/MCHBAR	
Address Offset:		6B4–6B7h	
Reset Value:		0000_0000h	
Access:		RO, RW-L-K, RW-L	
Bit	Attr	Reset Value	Description
31:24	RO	00h	Reserved
23	RW-L-K	0b	DRAM Throttle Lock (DTLOCK) This bit secures the DRAM throttling control registers DT*EW and DTC. Once a 1 is written to this bit, all of these configuration register bits become read-only.
22	RO	0b	Reserved
21	RW-L	0b	DRAM Bandwidth Based Throttling Enable (DBBTE) 0 = Bandwidth Threshold (WAB) is not used for throttling. 1 = Bandwidth Threshold (WAB) is used for throttling. If both Bandwidth based and thermal sensor based throttling modes are on and the thermal sensor trips, weighted average WAT is used for throttling.
20	RW-L	0b	DRAM Thermal Sensor Trip Enable (DTSTE) 0 = GMCH throttling is not initiated when the processor thermal sensor trips. 1 = GMCH throttling is initiated when the processor thermal sensor trips and the Filter output is equal to or exceeds thermal threshold WAT.
19	RO	0b	Reserved
18:16	RW-L	000b	Time Constant (TC) 000 = 2 ²⁸ Clocks 001 = 2 ²⁹ Clocks 010 = 2 ³⁰ Clocks 011 = 2 ³¹ Clocks Others = Reserved.
15:8	RW-L	00h	Weighted Average Bandwidth Limit (WAB) Average weighted bandwidth allowed per clock during for bandwidth based throttling. The processor does not allow any transactions to proceed on the system memory bus if the output of the filter equals or exceeds this value.
7:0	RW-L	00h	Weighted Average Thermal Limit (WAT) Average weighted bandwidth allowed per clock during for thermal sensor enabled throttling. The processor does not allow any transactions to proceed on the system memory bus if the output of the filter equals or exceeds this value.



2.8.37 SSKPD—Sticky Scratchpad Data Register

This register holds 64 writable bits with no functionality behind them. It is for the convenience of BIOS and graphics drivers.

B/D/F/Type:		0/0/0/MCHBAR	
Address Offset:		C20–C27h	
Reset Value:		0000_0000_0000_0000h	
Access:		RW/P	
Bit	Attr	Reset Value	Description
63:0	RW-S	00..00b	Scratchpad Data (SKPD) 4 Words of data storage

2.8.38 TSC1—Thermal Sensor Control 1 Register

This register controls the operation of the internal thermal sensor located in the graphics region of the die.

B/D/F/Type:		0/0/0/MCHBAR	
Address Offset:		1001–1002h	
Reset Value:		0000h	
Access:		RW-L, RO, RW, AF	
Bit	Attr	Reset Value	Description
15:14	RO	00b	Reserved
13:10	RW	0h	Digital Hysteresis Amount (DHA) This bit enables the analog hysteresis control to the thermal sensor. When enabled, about 1 degree of hysteresis is applied. This bit should normally be off in thermometer mode since the thermometer mode of the thermal sensor defeats the usefulness of analog hysteresis. 0 = Hysteresis disabled 1 = Analog hysteresis enabled. This setting falls within the same byte as the In Use bit in bit 8. Therefore, if this setting is read, software must write a 1 to bit 8 if it does not intend to maintain ownership of the Thermal Sensor resource.
9:9	RO	0h	Reserved
8	AF	0b	In Use (IU) Software semaphore bit. After a full MCH RESET, a read to this bit returns a 0. After the first read, subsequent reads will return a 1. A write of a 1 to this bit will reset the next read value to 0. Writing a 0 to this bit has no effect. Software can poll this bit until it reads a 0, and will then own the usage of the thermal sensor. This bit has no other effect on the hardware, and is only used as a semaphore among various independent software threads that may need to use the thermal sensor. Software that reads this register but does not intend to claim exclusive access of the thermal sensor must write a one to this bit if it reads a 0, in order to allow other software threads to claim it. See also THERM bit 15, which is an independent additional semaphore bit.
7:1	RO	00h	Reserved
0	RW-L	0b	Thermal Sensor Enable (TSE) This bit enables the thermal sensor logic in the core. The thermal sensor circuit EBB is enabled on PWROK. Lockable using TSTTPA1 bit 30. 0 = Disabled 1 = Enabled

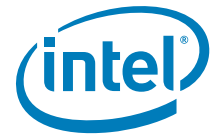

2.8.39 TSS1—Thermal Sensor Status 1 Register

This read only register provides trip point and other status of the thermal sensor.

B/D/F/Type:		0/0/0/MCHBAR	
Address Offset:		1004–1005h	
Reset Value:		0000h	
Access:		RO	
Bit	Attr	Reset Value	Description
15:11	RO	00h	Reserved
10	RO	0b	Thermometer Mode Output Valid (TMOV) 1 = The Thermometer mode is able to converge to a temperature and the TR register is reporting a reasonable estimate of the thermal sensor temperature. 0 = The Thermometer mode is off, or the temperature is out of range, or the TR register is being looked at before a temperature conversion has had time to complete.
9:9	RO	0h	Reserved
8	RO	0b	Reserved
7:6	RO	00b	Reserved
5	RO	0b	Catastrophic Trip Indicator (CTI) 1 = Internal thermal sensor temperature is above the catastrophic setting.
4	RO	0b	Hot Trip Indicator (HTI) 1 = Internal thermal sensor temperature is above the Hot setting.
3	RO	0b	Aux3 Trip Indicator (A3TI) 1 = Internal thermal sensor temperature is above the Aux3 setting.
2	RO	0b	Aux2 Trip Indicator (A2TI) 1 = Internal thermal sensor temperature is above the Aux2 setting.
1	RO	0b	Aux1 Trip Indicator (A1TI) 1 = Internal thermal sensor temperature is above the Aux1 setting.
0	RO	0b	Aux0 Trip Indicator (A0TI) 1 = Internal thermal sensor temperature is above the Aux0 setting.

2.8.40 TR1—Thermometer Read 1 Register

This register generally provides the uncalibrated counter value from the thermometer circuit when the Thermometer mode is enabled. See the temperature tables for the temperature calculations.

B/D/F/Type:		0/0/0/MCHBAR	
Address Offset:		1006h	
Reset Value:		FFh	
Access:		RO	
Bit	Attr	Reset Value	Description
7:0	RO	FFh	Thermometer Reading (TR) This field provides the current counter value. The current counter value corresponds to thermal sensor temperature if TSS[Thermometer mode Output Valid] = 1. This register has a straight binary encoding that will range from 00h to FFh. Note: When thermometer mode is disabled using TERATE register, TR will read FFh.



2.8.41 TOF1—Thermometer Offset 1 Register

This register is used for programming the thermometer offset.

B/D/F/Type:		0/0/0/MCHBAR	
Address Offset:		1007h	
Reset Value:		00h	
Access:		RW	
Bit	Attr	Reset Value	Description
7:0	RW	00h	Thermometer Offset (TOF) This value is used to adjust the current thermometer reading so that the TR value is not relative to a specific trip or calibration point, and is positive going for positive increases in temperature. The initial Reset Value is 00h and software must determine the correct temperature adjustment that corresponds to a zero reading by reading the fuses and referring to the temperature tables, and then programming the computed offset into this register.

2.8.42 RTR1—Relative Thermometer Read 1 Register

This register contains the relative temperature.

B/D/F/Type:		0/0/0/MCHBAR	
Address Offset:		1008h	
Reset Value:		00h	
Access:		RO	
Bit	Attr	Reset Value	Description
7:0	RO	00h	Relative Thermometer Reading (RTR1) In Thermometer mode, this register reports the relative temperature of the thermal sensor. This field provides a two's complement value of the thermal sensor relative to TOF. TR and HTPS can both vary between 0 and 255. $RTR1 = TR + TOF$ See also TSS [Thermometer mode Output Valid] In the Analog mode, the RTR field reports HTPS value.

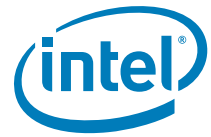

2.8.43 TSTTPA1—Thermal Sensor Temperature Trip Point A1 Register

This register sets the target values for some of the trip points in thermometer mode. See also TST [Direct DAC Connect Test Enable]. This register also reports the relative thermal sensor temperature. See also TSTTPB.

B/D/F/Type:		0/0/0/MCHBAR	
Address Offset:		1010–1013h	
Reset Value:		0000_0000h	
Access:		RW-L, RO	
Bit	Attr	Reset Value	Description
31	RW-L	0b	<p>Lock Bit for Aux0, Aux1, Aux2 and Aux3 Trip points (AUXLOCK)</p> <p>This bit, when written to a 1, locks the Aux x Trip point settings. This lock is reversible. The reversing procedure is the following sequence, which must be done in order, without any other configuration cycles in-between.</p> <pre>write testtpa1 04C1C202 write testtpa1 04C15202 write testtpa1 04C1C202</pre> <p>It is expected that the Aux x Trip point settings can be changed dynamically when this lock is not set.</p>
30	RW-L	0b	<p>Lock Bit for Catastrophic (LBC)</p> <p>This bit, when written to a 1, locks the Catastrophic programming interface, including bits 7:0 of TSTTPA[15-0], bits 15 and 9 of TSC, and bits 10 and 8 of TST1. This bit may only be set to a 0 by a hardware reset. Writing a 0 to this bit has no effect.</p>
29:16	RO	0000h	Reserved
15:8	RW-L	00h	<p>Hot Trip Point Setting (HTPS)</p> <p>Sets the target value for the Hot trip point. Lockable using TSTTPA1 bit 30.</p>
7:0	RW-L	00h	<p>Catastrophic Trip Point Setting (CTPS)</p> <p>This field sets the target for the Catastrophic trip point. See TST [Direct DAC Connect Test Enable]. Lockable using TSTTPA1 bit 30.</p>



2.8.44 TSTTPB1—Thermal Sensor Temperature Trip Point B1 Register

This register sets the target values for some of the trip points in the Thermometer mode. See also TSTTPA1.

B/D/F/Type:		0/0/0/MCHBAR	
Address Offset:		1014–1017h	
Reset Value:		0000_0000h	
Access:		RW-L	
Bit	Attr	Reset Value	Description
31:24	RW-L	00h	Aux 3 Trip Point Setting (A3TPS) Sets the target value for the Aux3 trip point Lockable by TSTTPA1[31].
23:16	RW-L	00h	Aux 2 Trip Point Setting (A2TPS) Sets the target value for the Aux2 trip point Lockable by TSTTPA1[31].
15:8	RW-L	00h	Aux 1 Trip Point Setting (A1TPS) Sets the target value for the Aux1 trip point Lockable by TSTTPA1[31].
7:0	RW-L	00h	Aux 0 Trip Point Setting (A0TPS) Sets the target value for the Aux0 trip point Lockable by TSTTPA1[31].

2.8.45 TS10BITMCTRL—Thermal Sensor 10-bit Mode Control Register

B/D/F/Type:		0/0/0/MCHBAR	
Address Offset:		1018–1019h	
Reset Value:		0000h	
Access:		RW-L	
BIOS Optimal Reset Value		00h	
Bit	Attr	Reset Value	Description
15	RW-L	0b	Thermal Sensor 10-bit Mode Enable (TS10BITEN) 0 = Normal operation (DTS 8-bit mode) 1 = DTS is operating in 10-bit mode. ROTS10BIT calculation is applied to TR1. Locked by LBC.
14:10	RO	0h	Reserved
9:0	RW-L	000h	Relative Offset when Thermal Sensor is Operating in 10-bit Mode (ROTS10BIT) Software needs to program this field such that the following equation is ensured to yield an 8-bit value. $TR = ROTS10BIT - \text{Raw Temp Code from DTS}$ TR[9:8] should always be 0. TR[7:0] is reported in the TR1 register. Locked by LBC.



2.8.46 HWTHROTCTRL1—Hardware Throttle Control 1 Register

B/D/F/Type:		0/0/0/MCHBAR	
Address Offset:		101Ch	
Reset Value:		00h	
Access:		RW-L, RO, RW-O	
Bit	Attr	Reset Value	Description
7	RW-L	0b	Internal Thermal Hardware Throttling Enable (ITHTE) This bit is a master enable for internal thermal sensor-based hardware throttling: 0 = Hardware actions using the internal thermal sensor are disabled. 1 = Hardware actions using the internal thermal sensor are enabled.
6	RO	0b	Reserved
5	RW-L	0b	Use Direct Catastrophic Trip for HOC (UDCTHOC) 1 = Catastrophic trip output of DTS circuit is used to control THRMTRIP#. 0 = Thermometer comparison to catastrophic trip value is used to control THRMTRIP#.
4	RW-L	0b	Throttle Zone Selection (TZS) This bit determines what temperature zones will enable autothrottling. This register applies to internal thermal sensor throttling. Lockable by bit 0 of this register. 0 = Hot, Aux2, and Catastrophic. 1 = Hot and Catastrophic.
3	RW-L	0b	Halt on Catastrophic (HOC) When this bit is set, THRMTRIP# is asserted on catastrophic trip to bring the platform down. A system reboot is required to bring the system out of a halt from the thermal sensor. Once the catastrophic trip point is reached, THRMTRIP# will stay asserted even if the catastrophic trip de-asserts before the platform is shut down.
2:1	RO	00b	Reserved
0	RW-O	0b	Hardware Throttling Lock Bit (HTL) This bit locks bits 7:1 of this register. When this bit is set to a one, the register bits are locked. It may only be set to a 0 by a hardware reset. Writing a 0 to this bit has no effect.



2.8.47 TIS1—Thermal Interrupt Status 1 Register

This register is used to report which specific error condition resulted in the D2F0 or D2F1 ERRSTS[Thermal Sensor event for SMI/SCI/SERR] or memory mapped IIR Thermal Event. Software can examine the current state of the thermal zones by examining the TSS. Software can distinguish internal or external Trip Event by examining TSS.

B/D/F/Type:		0/0/0/MCHBAR	
Address Offset:		101E–101Fh	
Reset Value:		0000h	
Access:		RO, RW1C	
Bit	Attr	Reset Value	Description
15:14	RO	00b	Reserved
13	RW1C	0b	Was Catastrophic Thermal Sensor Interrupt Event (WCTSIE) 1 = Indicates that a Catastrophic Thermal Sensor trip based on a higher to lower temperature transition thru the trip point. 0 = No trip for this event. Software must write a 1 to clear this status bit.
12	RW1C	0b	Was Hot Thermal Sensor Interrupt Event (WHTSIE) 1 = A Hot Thermal Sensor trip occurred based on a higher to lower temperature transition through the trip point. 0 = No trip for this event. Software must write a 1 to clear this status bit.
11	RW1C	0b	Was Aux 3 Thermal Sensor Interrupt Event (WA3TSIE) 1 = Aux 3 Thermal Sensor trip occurred based on a higher to lower temperature transition through the trip point. 0 = No trip for this event. Software must write a 1 to clear this status bit.
10	RW1C	0b	Was Aux 2 Thermal Sensor Interrupt Event (WA2TSIE) 1 = Aux 2 Thermal Sensor trip occurred based on a higher to lower temperature transition through the trip point. 0 = No trip for this event. Software must write a 1 to clear this status bit.
9	RW1C	0b	Was Aux 1 Thermal Sensor Interrupt Event (WA1TSIE) 1 = Aux 1 Thermal Sensor trip occurred based on a higher to lower temperature transition through the trip point. 0 = No trip for this event. Software must write a 1 to clear this status bit.
8	RW1C	0b	Was Aux 0 Thermal Sensor Interrupt Event (WA0TSIE) 1 = Aux 0 Thermal Sensor trip occurred based on a higher to lower temperature transition through the trip point. 0 = No trip for this event. Software must write a 1 to clear this status bit.
7:6	RO	00b	Reserved
5	RW1C	0b	Catastrophic Thermal Sensor Interrupt Event (CTSIE) 1 = A Catastrophic Thermal Sensor trip event occurred based on a lower to higher temperature transition through the trip point. 0 = No trip for this event. Software must write a 1 to clear this status bit.
4	RW1C	0b	Hot Thermal Sensor Interrupt Event (HTSIE) 1 = A Hot Thermal Sensor trip event occurred based on a lower to higher temperature transition through the trip point. 0 = No trip for this event. Software must write a 1 to clear this status bit.

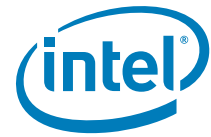

B/D/F/Type: Address Offset: Reset Value: Access:		O/O/O/MCHBAR 101E–101Fh 0000h RO, RW1C	
Bit	Attr	Reset Value	Description
3	RW1C	0b	Aux 3 Thermal Sensor Interrupt Event (A3TSIE) 1 = Aux 3 Thermal Sensor trip event occurred based on a lower to higher temperature transition through the trip point. 0 = No trip for this event. Software must write a 1 to clear this status bit.
2	RW1C	0b	Aux 2 Thermal Sensor Interrupt Event (A2TSIE) 1 = Aux 2 Thermal Sensor trip event occurred based on a lower to higher temperature transition thru the trip point. 0 = No trip for this event. Software must write a 1 to clear this status bit.
1	RW1C	0b	Aux 1 Thermal Sensor Interrupt Event (A1TSIE) 1 = Aux1 Thermal Sensor trip event occurred based on a lower to higher temperature transition thru the trip point. 0 = No trip for this event. Software must write a 1 to clear this status bit.
0	RW1C	0b	Aux 0 Thermal Sensor Interrupt Event (A0TSIE) 1 = Aux 0 Thermal Sensor trip event occurred based on a lower to higher temperature transition through the trip point. 0 = No trip for this event. Software must write a 1 to clear this status bit. The following scenario is possible. An interrupt is initiated on a rising temperature trip, the appropriate DMI cycles are generated, and eventually the software services the interrupt and sees a rising temperature trip as the cause in the status bits for the interrupts. Assume that the software then goes and clears the local interrupt status bit in the TIS register for that trip event. It is possible at this point that a falling temperature trip event occurs before the software has had the time to clear the global interrupts status bit. But since software has already looked at the status register before this event happened, software may not clear the local status flag for this event. Therefore, after the global interrupt is cleared by software, software must look at the instantaneous status in the TSS register.



2.8.48 TERENCE—Thermometer Mode Enable and Rate Register

This common register helps select between the analog and the thermometer mode and also helps select the DAC settling timer.

B/D/F/Type:		0/0/0/MCHBAR	
Address Offset:		1070h	
Reset Value:		00h	
Access:		RO, RW	
Bit	Attr	Reset Value	Description
7:4	RO	0h	Reserved
3:0	RW	0h	<p>Thermometer Mode Enable and Rate (TE)</p> <p>If analog thermal sensor mode is not enabled by setting these bits to 0000b, these bits enable the thermometer mode functions and set the Thermometer mode controller rate. When the Thermometer mode is disabled and TSC1[TSC] = enabled, the analog sensor mode should be fully functional.</p> <p>In the analog sensor mode, the Catastrophic trip is functional. The other trip points are not functional in this mode.</p> <p>When Thermometer mode is enabled, all the trip points (Catastrophic, Hot, Aux 0, Aux 1, Aux 2) will all operate using the programmed trip points and Thermometer mode rate.</p> <p>Note: When disabling the Thermometer mode while the thermometer is running, the Thermometer mode controller will finish the current cycle.</p> <p>Note: During boot, all other thermometer mode registers (except lock bits) should be programmed appropriately before enabling the Thermometer Mode.</p> <p>Thermometer rate select (that is, fast clock select)</p> <p>0000 = Thermometer mode disabled (that is, analog sensor mode)</p> <p>0001 = enabled, 2 usec</p> <p>0010 = enabled, 4 usec</p> <p>0011 = enabled, 6 usec</p> <p>0100 = enabled, 8 usec</p> <p>0101 = enabled, 10 usec</p> <p>0110 = enabled, 12 usec</p> <p>0111 = enabled, 14 usec</p> <p>all other permutations reserved;</p> <p>1111 = enabled, 8 clock mode (for testing digital logic)</p>

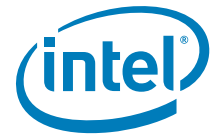

2.8.49 TERRCMD—Thermal Error Command Register

This register select which errors are generate a SERR DMI interface special cycle, as enabled by ERRCMD [SERR Thermal Sensor event]. The SERR and SCI must not be enabled at the same time for the thermal sensor event.

B/D/F/Type:		0/0/0/MCHBAR	
Address Offset:		10E4h	
Reset Value:		00h	
Access:		RO, RW	
Bit	Attr	Reset Value	Description
7:6	RO	00b	Reserved
5	RW	0b	SERR on Catastrophic Thermal Sensor Event (CATSERR) 1 = Does not mask the generation of a SERR DMI cycle on a catastrophic thermal sensor trip. 0 = Disable. Reporting of this condition using SERR messaging is disabled.
4	RW	0b	SERR on Hot Thermal Sensor Event (HOTSERR) 1 = Do not mask the generation of a SERR DMI cycle on a Hot thermal sensor trip. 0 = Disable. Reporting of this condition using SERR messaging is disabled.
3	RW	0b	SERR on Aux 3 Thermal Sensor Event (AUX3SERR) 1 = Do not mask the generation of a SERR DMI cycle on a Aux3 thermal sensor trip 0 = Disable. Reporting of this condition using SERR messaging is disabled.
2	RW	0b	SERR on Aux 2 Thermal Sensor Event (AUX2SERR) 1 = Do not mask the generation of a SERR DMI cycle on a Aux2 thermal sensor trip 0 = Disable. Reporting of this condition using SERR messaging is disabled.
1	RW	0b	SERR on Aux 1 Thermal Sensor Event (AUX1SERR) 1 = Do not mask the generation of a SERR DMI cycle on a Aux1 thermal sensor trip 0 = Disable. Reporting of this condition using SERR messaging is disabled.
0	RW	0b	SERR on Aux 0 Thermal Sensor Event (AUX0SERR) 1 = Do not mask the generation of a SERR DMI cycle on a Aux0 thermal sensor trip 0 = Disable. Reporting of this condition using SERR messaging is disabled.



2.8.50 TSMICMD—Thermal SMI Command Register

This register selects specific errors to generate a SMI DMI cycle, as enabled by the SMI Error Command Register[SMI on Thermal Sensor Trip].

B/D/F/Type:		0/0/0/MCHBAR	
Address Offset:		10E5h	
Reset Value:		00h	
Access:		RO, RW	
Bit	Attr	Reset Value	Description
7:6	RO	00b	Reserved
5	RW	0b	SMI on Catastrophic Thermal Sensor Trip (CATSMI) 1 = Does not mask the generation of an SMI DMI cycle on a catastrophic thermal sensor trip. 0 = Disable reporting of this condition using SMI messaging.
4	RW	0b	SMI on Hot Thermal Sensor Trip (HOTSMI) 1 = Does not mask the generation of an SMI DMI cycle on a Hot thermal sensor trip. 0 = Disable reporting of this condition using SMI messaging.
3	RW	0b	SMI on AUX3 Thermal Sensor Trip (AUX3SMI) 1 = Does not mask the generation of an SMI DMI cycle on an Aux3 thermal sensor trip. 0 = Disable reporting of this condition using SMI messaging.
2	RW	0b	SMI on AUX2 Thermal Sensor Trip (AUX2SMI) 1 = Does not mask the generation of an SMI DMI cycle on an Aux2 thermal sensor trip. 0 = Disable reporting of this condition using SMI messaging.
1	RW	0b	SMI on AUX1 Thermal Sensor Trip (AUX1SMI) 1 = Does not mask the generation of an SMI DMI cycle on an Aux1 thermal sensor trip. 0 = Disable reporting of this condition using SMI messaging.
0	RW	0b	SMI on AUX0 Thermal Sensor Trip (AUX0SMI) 1 = Does not mask the generation of an SMI DMI cycle on an Aux0 thermal sensor trip. 0 = Disable reporting of this condition using SMI messaging.

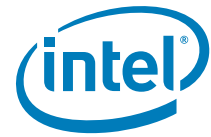

2.8.51 TSCICMD—Thermal SCI Command Register

This register selects specific errors to generate a SCI DMI cycle, as enabled by the SCI Error Command Register[SCI on Thermal Sensor Trip]. The SCI and SERR must not be enabled at the same time for the thermal sensor event.

B/D/F/Type:		0/0/0/MCHBAR	
Address Offset:		10E6h	
Reset Value:		00h	
Access:		RW, RO	
Bit	Attr	Reset Value	Description
7:6	RO	00b	Reserved
5	RW	0b	SCI on Catastrophic Thermal Sensor Trip (CATSCI) 1 = Does not mask the generation of an SCI DMI cycle on a catastrophic thermal sensor trip. 0 = Disable reporting of this condition using SCI messaging.
4	RW	0b	SCI on Hot Thermal Sensor Trip (HOTSCI) 1 = Does not mask the generation of an SCI DMI cycle on a Hot thermal sensor trip. 0 = Disable reporting of this condition using SCI messaging.
3	RW	0b	SCI on AUX 3 Thermal Sensor Trip (AUX3SCI) 1 = Does not mask the generation of an SCI DMI cycle on an Aux3 thermal sensor trip. 0 = Disable reporting of this condition using SCI messaging.
2	RW	0b	SCI on AUX 2 Thermal Sensor Trip (AUX2SCI) 1 = Does not mask the generation of an SCI DMI cycle on an Aux2 thermal sensor trip. 0 = Disable reporting of this condition using SCI messaging.
1	RW	0b	SCI on AUX 1 Thermal Sensor Trip (AUX1SCI) 1 = Does not mask the generation of an SCI DMI cycle on an Aux1 thermal sensor trip. 0 = Disable reporting of this condition using SCI messaging.
0	RW	0b	SCI on AUX 0 Thermal Sensor Trip (AUX0SCI) 1 = Does not mask the generation of an SCI DMI cycle on an Aux0 thermal sensor trip. 0 = Disable reporting of this condition using SCI messaging.



2.8.52 TINTRCMD—Thermal INTR Command Register

This register selects specific errors to generate a INT DMI cycle.

B/D/F/Type:		0/0/0/MCHBAR	
Address Offset:		10E7h	
Reset Value:		00h	
Access:		RO, RW	
Bit	Attr	Reset Value	Description
7:6	RO	00b	Reserved
5	RW	0b	INTR on Catastrophic Thermal Sensor Trip (CATINTR) 1 = A INTR DMI cycle is generated by the processor
4	RW	0b	INTR on Hot Thermal Sensor Trip (HOTINTR) 1 = A INTR DMI cycle is generated by the processor
3	RW	0b	INTR on AUX3 Thermal Sensor Trip (AUX3INTR) 1 = A INTR DMI cycle is generated by the processor
2	RW	0b	INTR on AUX2 Thermal Sensor Trip (AUX2INTR) 1 = A INTR DMI cycle is generated by the processor
1	RW	0b	INTR on AUX1 Thermal Sensor Trip (AUX1INTR) 1 = A INTR DMI cycle is generated by the processor
0	RW	0b	INTR on AUX0 Thermal Sensor Trip (AUX0INTR) 1 = A INTR DMI cycle is generated by the processor

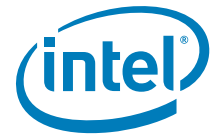

2.8.53 EXTTS0—External Thermal Sensor Control and Status Register

B/D/F/Type:		0/0/0/MCHBAR	
Address Offset:		10EC–10EDh	
Reset Value:		0000h	
Access:		RO, RW-O, RW-L	
Bit	Attr	Reset Value	Description
15	RW-O	0b	<p>External Sensor Enable (ESE)</p> <p>Setting this bit to 1 locks the lockable bits in this register. This bit may only be set to a zero by a hardware reset. Once locked, writing a 0 to bit has no effect. EXTTS0 and EXTTS1 input signal pins are dedicated for external thermal sensor use. An asserted External Thermal Sensor Trip signal can also cause a SCI, SMI, SERR or INTR interrupt in the same manner as the Internal Sensor can. A "0" on the pins can be used to trigger throttling. If both internal sensor throttling and external sensor throttling are enabled, either can initiate throttling. The AS0 and AS1 bits of this register allow control of what action is triggered by external sensor trips. The processor Throttling select bit controls the type of throttling action that will happen, and the {AS0, AS1} bits control what trip actions will result.</p> <p>0 = External Sensor input is disabled. 1 = External Sensor input is enabled.</p>
14	RO	0b	Reserved
13	RW-L	0b	<p>Select between EXTTS PIN 0 and 1 (EXTTPINSEL)</p> <p>0 = Use EXTTS Pin 0 for Thermal throttling, based of EXTTPMTRIP, EXTTFMX and SD2X. 1 = Use EXTTS Pin 1 for the above.</p>
12	RW-L	0b	<p>EXTTS Based Power Monitor Trip (EXTTPMTRIP)</p> <p>When this is set on extts, bit 0 can be programmed to look like a power-monitor trip</p> <ol style="list-style-type: none"> will be OR'ed with the Global monitor/Gfx monitor so that, when programmed for gfx throttle, when EXTTS# is asserted at the sample point, it will look like a monitor trip and force RP down by the programmed amount EXTTS# is only sampled on the sampling window for graphics throttling, so even if both the Gfx monitor and global monitor are disabled, the sampling window must be programmed in order to have EXTTS# work as a graphics throttle
11	RW-L	0b	<p>Force DDR on EXTTS bit (EXTTFMX)</p> <p>Enables forcing of DDR to specified MX state in registers EXTTSMXST when the selected EXTTS bit 0 or 1(from exttpinsel field) is asserted.</p> <p>Note: PMU looks at all enabled throttling and picks the highest value of Mx for EXTTS#, or from the global power M state, or any other throttling and passes it to the SD unit</p>
10:8	RW-L	000b	<p>EXTTSS Programmable MX state (EXTTSMXST)</p> <p>MX state to which DDR to be forced to if EXTTS bit 0 asserts and Force DDR on EXTTS bit (EXTTFMX) is enabled.</p> <p>Note: PMU looks at all enabled throttling and picks the highest value of Mx for EXTTS#, or from the global power M state, or any other throttling and passes it to the SD unit.</p>
7	RW-L	0b	<p>Force SD 2X Refresh Rate (SD2X)</p> <p>When enabled on EXTTS bit 0 getting asserted will force memory into 2X Refresh mode.</p>



B/D/F/Type: Address Offset: Reset Value: Access:		O/O/O/MCHBAR 10EC–10EDh 0000h RO, RW-O, RW-L	
Bit	Attr	Reset Value	Description
6	RW-L	0b	Throttling Type Select (TTS) Lockable by EXTTSCS [External Sensor Enable]. If External Thermal Sensor Enable = 1, then 0 = DRAM throttling based on the settings in the Device 0 MCHBAR DRAM Throttling Control register 1 = processor throttling, based on the settings in the Device 0 MCHBAR processor Throttling Control Register and the Device 2 Graphics Render Throttle Control Register [Catastrophic and Hot Hardware controlled Thermal Throttle Duty Cycle]; otherwise, (TTS) has no meaning. Software must keep this bit at 0.
5	RW-L	0b	EXTT51 Action Select (AS1) Lockable by EXTTSCS [External Sensor Enable]. If External Thermal Sensor Enable = 1, then 0 = The external sensor trip functions same as a Thermometer mode hot trip 1 = The external sensor trip functions same as a Thermometer mode aux0 trip
4	RW-L	0b	EXTT50 Action Select (AS0) Lockable by EXTTSCS [External Sensor Enable]. If External Thermal Sensor Enable = 1, then 0 = The external sensor trip functions same as a Thermometer mode catastrophic trip 1 = The external sensor trip functions same as a Thermometer mode hot trip
3	RO	0b	EXTT50 Trip Indicator (S0TI) 1 = An externally monitored temperature is exceeding the programmed setting of its external thermal sensor. 0 = This externally monitored temperature is not exceeding the programmed setting of its external thermal sensor.
2	RO	0b	EXTT51 Trip Indicator (S1TI) 1 = An externally monitored temperature is exceeding the programmed setting of its external thermal sensor. 0 = This externally monitored temperature is not exceeding the programmed setting of its external thermal sensor.
1	RO	0b	Reserved
0	RW-L	0b	External Thermal Sensor Signals Routing Control (EXTTSSRC) 0 = Route all external sensor signals to affect internal thermal sensor registers, as appropriate 1 = No affect of external sensor signals to internal thermal sensor registers

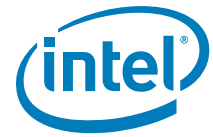

2.8.54 DDRMPLL1—DDR PLL BIOS Register

This register is for DDR PLL register programming.

B/D/F/Type:		0/0/0/MCHBAR	
Address Offset:		2C20–2C22h	
Reset Value:		00000Ch	
Access:		RO, RW, RW-S	
Bit	Attr	Reset Value	Description
23:12	RO	00b	Reserved
11	RW-S	0b	Alternative VCO Select (VCOSEL) 0 = Use VCO A 1 = Use VCO B VCO A is recommended Default value.
10	RW-S	0b	Post Divide For DDR 800 Mode (DIVSEL) Post Divider value 1 versus 2. 0 = Divide by 1 1 = Divide by 2 Only DRR 800 uses the additional divide by 2 due to the increased VCO speed used by DRR 800 mode.
9:8	RW-S	0b	Reserved
7	RO	0b	Reserved
6:1	RW	000110b	Feedback Divider Ratio[6:1] (FBRATIO) Encoding for bits 7:0 Data edge rate in MHz 0Ch = 800 MHz 10h = 1066 MHz 14h = 1333 MHz
0	RO	0b	Feedback Divider Ratio[0] (FBRATIONLSB) FB ratios are always even so the LSB is not needed. A write to this bit will be dropped; will have no effect.



2.9 EPBAR Registers

2.9.1 EPPVCCAP1—EP Port VC Capability Register 1

This register describes the configuration of PCI Express Virtual Channels associated with this port.

B/D/F/Type:		0/0/0/PXPEPBAR	
Address Offset:		4–7h	
Reset Value:		0000_0001h	
Access:		RO, RWO	
Bit	Attr	Reset Value	Description
31:12	RO	00000h	Reserved
11:10	RO	00b	Port Arbitration Table Entry Size (PATES) This field indicates that the size of the Port Arbitration table entry is 1 bit.
9:8	RO	00b	Reference Clock (RC) This field indicates the reference clock for Virtual Channels that support time-based WRR Port Arbitration. 00 = 100 ns
7	RO	0b	Reserved
6:4	RO	000b	Low Priority Extended VC Count (LPEVCC) This field indicates the number of (extended) Virtual Channels in addition to the default VC belonging to the low-priority VC (LPVC) group that has the lowest priority with respect to other VC resources in a strict-priority VC Arbitration. The value of 0 in this field implies strict VC arbitration.
3	RO	0b	Reserved
2:0	RW-O	001b	Extended VC Count (EVCC) This field indicates the number of (extended) Virtual Channels in addition to the default VC supported by the device.

2.9.2 EPPVCCTL—EP Port VC Control Register

B/D/F/Type:		0/0/0/PXPEPBAR	
Address Offset:		C–Dh	
Reset Value:		0000h	
Access:		RO, RW	
Bit	Attr	Reset Value	Description
15:4	RO	000h	Reserved
3:1	RW	000b	VC Arbitration Select (VCAS) This field will be programmed by software to the only possible value as indicated in the VC Arbitration Capability field. The value 000b when written to this field will indicate the VC arbitration scheme is hardware fixed (in the root complex). This field cannot be modified when more than one VC in the LPVC group is enabled.
0	RO	0b	Reserved for Load VC Arbitration Table

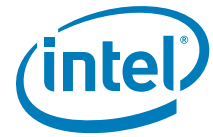

2.9.3 EPVCOCTL—EP VC 0 Resource Control Register

This register controls the resources associated with Egress Port Virtual Channel 0.

B/D/F/Type:		0/0/0/PXPEPBAR	
Address Offset:		14–17h	
Reset Value:		8000_00FFh	
Access:		RO, RW	
Bit	Attr	Reset Value	Description
31	RO	1b	VCO Enable (VCOE) For VCO, this is hardwired to 1 and read only as VCO can never be disabled.
30:27	RO	0h	Reserved
26:24	RO	000b	VCO ID (VCOID) Assigns a VC ID to the VC resource. For VCO this is hardwired to 0 and read only.
23:20	RO	0h	Reserved
19:17	RW	000b	Port Arbitration Select (PAS) This field configures the VC resource to provide a particular Port Arbitration service. The value of 0h corresponds to the bit position of the only asserted bit in the Port Arbitration Capability field.
16:8	RO	000h	Reserved
7:1	RW	7Fh	TC/VCO Map (TCVCOM) This field indicates the TCs (Traffic Classes) that are mapped to the VC resource. Bit locations within this field correspond to TC values. For example, when bit 7 is set in this field, TC7 is mapped to this VC resource. When more than one bit in this field is set, it indicates that multiple TCs are mapped to the VC resource. In order to remove one or more TCs from the TC/VC Map of an enabled VC, software must ensure that no new or outstanding transactions with the TC labels are targeted at the given Link.
0	RO	1b	TC0/VCO Map (TC0VCOM) Traffic Class 0 is always routed to VCO.



2.9.4 EPVCORCAP—EP VC 0 Resource Capability Register

B/D/F/Type:		0/0/0/PXPEPBAR	
Address Offset:		10–13h	
Reset Value:		0000_0001h	
Access:		RO	
Bit	Attr	Reset Value	Description
31:24	RO	00h	Reserved for Port Arbitration Table Offset No VC0 port arbitration necessary.
23	RO	0b	Reserved
22:16	RO	00h	Reserved for Maximum Time Slots No VC0 port arbitration necessary.
15	RO	0b	Reject Snoop Transactions (RSNPT) 0 = Transactions with or without the No Snoop bit set within the TLP header are allowed on this VC. 1 = When Set, any transaction for which the No Snoop attribute is applicable but is not Set within the TLP Header will be rejected as an Unsupported Request.
14:8	RO	00h	Reserved
7:0	RO	01h	Port Arbitration Capability (PAC) This field indicates types of Port Arbitration supported by this VC0 resource. The Reset Value of 01h indicates that the only port arbitration capability for VC0 is non-configurable, hardware-fixed arbitration scheme.



2.9.5 EPVC1RCTL—EP VC 1 Resource Control Register

This register controls the resources associated with PCI Express Virtual Channel 1.

B B/D/F/Type:		0/0/0/PXPEPBAR	
Address Offset:		20–23h	
Reset Value:		0100_0000h	
Access:		RW, RO	
Bit	Attr	Reset Value	Description
31	RW	0b	<p>VC1 Enable (VC1E)</p> <p>This bit will be ignored by the hardware. The bit is RW for specification compliance, but writing to it will result in no behavior change in the hardware (other than the bit value reflecting the written value).</p> <p>0 = Virtual Channel is disabled. 1 = Virtual Channel is enabled.</p> <p>See exceptions in notes below.</p> <p>Software must use the VC Negotiation Pending bit to check whether the VC negotiation is complete. When VC Negotiation Pending bit is cleared, a 1 read from this VC Enable bit indicates that the VC is enabled (Flow Control Initialization is completed for the PCI Express port). A 0 read from this bit indicates that the Virtual Channel is currently disabled.</p> <p>Notes:</p> <ol style="list-style-type: none"> To enable a Virtual Channel, the VC Enable bits for that Virtual Channel must be set in both Components on a Link. To disable a Virtual Channel, the VC Enable bits for that Virtual Channel must be cleared in both Components on a Link. Software must ensure that no traffic is using a Virtual Channel at the time it is disabled. Software must fully disable a Virtual Channel in both Components on a Link before re-enabling the Virtual Channel.
30:27	RO	0h	Reserved
26:24	RW	001b	<p>VC1 ID (VC1ID)</p> <p>Assigns a VC ID to the VC resource. Assigned value must be non-zero. This field can not be modified when the VC is already enabled.</p>
23:20	RO	0h	Reserved
19:17	RW	000b	<p>Port Arbitration Select (PAS)</p> <p>This field configures the VC resource to provide a particular Port Arbitration service. The Reset Value of 0h corresponds to bit position of the only asserted bit in the Port Arbitration Capability field.</p>
16	RO	0b	Reserved
15:8	RO	00h	Reserved
7:1	RW	00h	<p>TC/VC1 Map (TCVC1M)</p> <p>This field indicates the TCs (Traffic Classes) that are mapped to the VC resource. Bit locations within this field correspond to TC values. For example, when bit 7 is set in this field, TC7 is mapped to this VC resource.</p> <p>When more than one bit in this field is set, it indicates that multiple TCs are mapped to the VC resource. In order to remove one or more TCs from the TC/VC Map of an enabled VC, software must ensure that no new or outstanding transactions with the TC labels are targeted at the given Link.</p>
0	RO	0b	<p>TC0/VC1 Map (TC0/VC1M)</p> <p>Traffic Class 0 is always routed to VC0.</p>



2.9.6 EPVC1RSTS—EP VC 1 Resource Status Register

B/D/F/Type:		0/0/0/PXPEPBAR	
Address Offset:		26–27h	
Reset Value:		0000h	
Access:		RO	
Bit	Attr	Reset Value	Description
15:2	RO	0000h	Reserved and zero
1	RO	0b	VC1 Negotiation Pending (VC1NP) 0 = The VC negotiation is complete. 1 = The VC resource is still in the process of negotiation (initialization or disabling). For this non-default Virtual Channel, software may use this bit when enabling or disabling the VC. Before using a Virtual Channel, software must check whether the VC Negotiation Pending fields for that Virtual Channel are cleared in both Components on a Link.
0	RO	0b	Reserved for Port Arbitration Table Status (PATS)



2.10 PCI Device 1 Registers

Table 2-7. PCI Express* Device 1 Register Address Map

Address Offset	Register Symbol	Register Name	Reset Value	Access
0–1h	VID1	Vendor Identification	8086h	RO
2–3h	DID1	Device Identification	0041h	RO
4–5h	PCICMD1	PCI Command	0000h	RO, RW
6–7h	PCISTS1	PCI Status	0010h	RO, RW1C
8h	RID1	Revision Identification	12h	RO
9–Bh	CC1	Class Code	060400h	RO
Ch	CL1	Cache Line Size	00h	RW
Eh	HDR1	Header Type	01h	RO
18h	PBUSN1	Primary Bus Number	00h	RO
19h	SBUSN1	Secondary Bus Number	00h	RW
1Ah	SUBUSN1	Subordinate Bus Number	00h	RW
1Ch	IOBASE1	I/O Base Address	F0h	RW, RO
1Dh	IOLIMIT1	I/O Limit Address	00h	RW, RO
1E–1Fh	SSTS1	Secondary Status	0000h	RW1C, RO
20–21h	MBASE1	Memory Base Address	FFF0h	RW, RO
22–23h	MLIMIT1	Memory Limit Address	0000h	RW, RO
24–25h	PMBASE1	Prefetchable Memory Base Address	FFF1h	RW, RO
26–27h	PMLIMIT1	Prefetchable Memory Limit Address	0001h	RW, RO
28–2Bh	PMBASEU1	Prefetchable Memory Base Address Upper	0000_0000h	RW
2C–2Fh	PMLIMITU1	Prefetchable Memory Limit Address Upper	0000_0000h	RW
34h	CAPPTR1	Capabilities Pointer	88h	RO
3Ch	INTRLINE1	Interrupt Line	00h	RW
3Dh	INTRPIN1	Interrupt Pin	01h	RO
3E–3Fh	BCTRL1	Bridge Control	0000h	RO, RW
40–7Eh	RSVD	Reserved	0h	RO
7Fh	CAPL	Capabilities List Control	02h	RO, RW
80–83h	PM_CAPID1	Power Management Capabilities	C8039001h	RO
84–87h	PM_CS1	Power Management Control/Status	0000_0008h	RO, RW-S, RW
88–8Bh	SS_CAPID	Subsystem ID and Vendor ID Capabilities	0000800Dh	RO
8C–8Fh	SS	Subsystem ID and Subsystem Vendor ID	00008086h	RW-O
90–91h	MSI_CAPID	Message Signaled Interrupts Capability ID	A005h	RO
92–93h	MC	Message Control	0000h	RO, RW
94–97h	MA	Message Address	0000_0000h	RW, RO
98–99h	MD	Message Data	0000h	RW
A0–A1h	PEG_CAPL	PCI Express-G Capability List	0010h	RO
A2–A3h	PEG_CAP	PCI Express-G Capabilities	0142h	RO, RW-O
A4–A7h	DCAP	Device Capabilities	00008000h	RO



Table 2-7. PCI Express* Device 1 Register Address Map

Address Offset	Register Symbol	Register Name	Reset Value	Access
A8–A9h	DCTL	Device Control	0000h	RO, RW
AA–ABh	DSTS	Device Status	0000h	RO, RW1C
AC–AFh	LCAP	Link Capabilities	02214D02h	RO, RW-O
B0–B1h	LCTL	Link Control	0000h	RO, RW, RW-SC
B2–B3h	LSTS	Link Status	1000h	RW1C, RO
B4–B7h	SLOTCAP	Slot Capabilities	00040000h	RW-O, RO
B8–B9h	SLOTCTL	Slot Control	0000h	RO, RW
BA–BBh	SLOTSTS	Slot Status	0000h	RO, RW1C
BC–BDh	RCTL	Root Control	0000h	RW, RO
BE–BFh	RSVD	Reserved	0h	RO
C0–C3h	RSTS	Root Status	0000_0000h	RO, RW1C
D0–D1h	LCTL2	Link Control 2	0002h	RO, RW-S, RW
D2–D3h	LSTS2	Link Status 2	0000h	RO
EC–EFh	PEGLC	PCI Express-G Legacy Control	0000_0000h	RO, RW



2.10.1 VID1—Vendor Identification Register

This register combined with the Device Identification register uniquely identify any PCI device.

B/D/F/Type:		0/1/0/PCI	
Address Offset:		0–1h	
Reset Value:		8086h	
Access:		RO	
Bit	Attr	Reset Value	Description
15:0	RO	8086h	Vendor Identification (VID1) PCI standard identification for Intel.

2.10.2 DID1—Device Identification Register

This register combined with the Vendor Identification register uniquely identifies any PCI device.

B/D/F/Type:		0/1/0/PCI	
Address Offset:		2–3h	
Reset Value:		0041h	
Access:		RO	
Bit	Attr	Reset Value	Description
15:4	RO	004h	Device Identification Number (DID1(UB)) Identifier assigned to the processor device 1 (virtual PCI-to-PCI bridge, PCI Express Graphics port).
3:2	RO	00b	Device Identification Number (DID1(HW)) Identifier assigned to the processor device 1 (virtual PCI-to-PCI bridge, PCI Express Graphics port).
1:0	RO	01b	Device Identification Number (DID1(LB)) Identifier assigned to the processor device 1 (virtual PCI-to-PCI bridge, PCI Express Graphics port).

2.10.3 PCICMD1—PCI Command Register

B/D/F/Type:		0/1/0/PCI	
Address Offset:		4–5h	
Reset Value:		0000h	
Access:		RO, RW	
Bit	Attr	Reset Value	Description
15:11	RO	00h	Reserved
10	RW	0b	INTA Assertion Disable (INTAAD) 0 = This device is permitted to generate INTA interrupt messages. 1 = This device is prevented from generating interrupt messages. Any INTA emulation interrupts already asserted must be de-asserted when this bit is set. Only affects interrupts generated by the device (PCI INTA from a PME or Hot Plug event) controlled by this command register. It does not affect upstream MSIs, upstream PCI INTA-INTD assert and de-assert messages.
9	RO	0b	Fast Back-to-Back Enable (FB2B) Not Applicable or Implemented. Hardwired to 0.



B/D/F/Type: Address Offset: Reset Value: Access:		0/1/0/PCI 4–5h 0000h RO, RW	
Bit	Attr	Reset Value	Description
8	RW	0b	<p>SERR# Message Enable (SERRE1) This bit controls Device 1 SERR# messaging. The processor communicates the SERR# condition by sending an SERR message to the PCH. This bit, when set, enables reporting of non-fatal and fatal errors detected by the device to the Root Complex. Note that errors are reported if enabled either through this bit or through the PCI-Express specific bits in the Device Control Register.</p> <p>In addition, for Type 1 configuration space header devices, this bit, when set, enables transmission by the primary interface of ERR_NONFATAL and ERR_FATAL error messages forwarded from the secondary interface. This bit does not affect the transmission of forwarded ERR_COR messages.</p> <p>0 = The SERR message is generated by the processor for Device 1 only under conditions enabled individually through the Device Control Register. 1 = The processor is enabled to generate SERR messages which will be sent to the PCH for specific Device 1 error conditions generated/detected on the primary side of the virtual PCI to PCI bridge (not those received by the secondary side). The status of SERRs generated is reported in the PCISTS1 register.</p>
7	RO	0b	<p>Reserved Not Applicable or Implemented. Hardwired to 0.</p>
6	RW	0b	<p>Parity Error Response Enable (PERRE) Controls whether or not the Master Data Parity Error bit in the PCI Status register can be set.</p> <p>0 = Master Data Parity Error bit in PCI Status register can NOT be set. 1 = Master Data Parity Error bit in PCI Status register CAN be set.</p>
5	RO	0b	<p>VGA Palette Snoop (VGAPS) Not Applicable or Implemented. Hardwired to 0.</p>
4	RO	0b	<p>Memory Write and Invalidate Enable (MWIE) Not Applicable or Implemented. Hardwired to 0.</p>
3	RO	0b	<p>Special Cycle Enable (SCE) Not Applicable or Implemented. Hardwired to 0.</p>
2	RW	0b	<p>Bus Master Enable (BME) This bit controls the ability of the PEG port to forward Memory and IO Read/Write Requests in the upstream direction.</p> <p>0 = This device is prevented from making memory or IO requests to its primary bus. Note that according to PCI Specification, as MSI interrupt messages are in-band memory writes, disabling the bus master enable bit prevents this device from generating MSI interrupt messages or passing them from its secondary bus to its primary bus. Upstream memory writes/reads, IO writes/reads, peer writes/reads, and MSIs will all be treated as illegal cycles. Writes are forwarded to memory address C0000h with byte enables de-asserted. Reads will be forwarded to memory address C0000h and will return Unsupported Request status (or Master abort) in its completion packet.</p> <p>1 = This device is allowed to issue requests to its primary bus. Completions for previously issued memory read requests on the primary bus will be issued when the data is available. This bit does not affect forwarding of Completions from the primary interface to the secondary interface.</p>
1	RW	0b	<p>Memory Access Enable (MAE) 0 = All of device 1's memory space is disabled. 1 = Enable the Memory and Pre-fetchable memory address ranges defined in the MBASE1, MLIMIT1, PMBASE1, and PMLIMIT1 registers.</p>
0	RW	0b	<p>IO Access Enable (IOAE) 0 = All of device 1's I/O space is disabled. 1 = Enable the I/O address range defined in the IOBASE1, and IOLIMIT1 registers.</p>



2.10.4 PCISTS1—PCI Status Register

This register reports the occurrence of error conditions associated with primary side of the "virtual" Host-PCI Express bridge embedded within the processor.

B/D/F/Type:		0/1/0/PCI	
Address Offset:		6–7h	
Reset Value:		0010h	
Access:		RO, RW1C	
Bit	Attr	Reset Value	Description
15	RO	0b	Detected Parity Error (DPE) Not Applicable or Implemented. Hardwired to 0. Parity (generating poisoned TLPs) is not supported on the primary side of this device (we don't do error forwarding).
14	RW1C	0b	Signaled System Error (SSE) This bit is set when this Device sends an SERR due to detecting an ERR_FATAL or ERR_NONFATAL condition and the SERR Enable bit in the Command register is '1'. Both received (if enabled by BCTRL1[1]) and internally detected error messages do not affect this field.
13	RO	0b	Received Master Abort Status (RMAS) Not Applicable or Implemented. Hardwired to 0. The concept of a master abort does not exist on primary side of this device.
12	RO	0b	Received Target Abort Status (RTAS) Not Applicable or Implemented. Hardwired to 0. The concept of a target abort does not exist on primary side of this device.
11	RO	0b	Signaled Target Abort Status (STAS) Not Applicable or Implemented. Hardwired to 0. The concept of a target abort does not exist on primary side of this device.
10:9	RO	00b	DEVSELB Timing (DEVT) This device is not the subtractively decoded device on bus 0. This bit field is therefore hardwired to 00 to indicate that the device uses the fastest possible decode.
8	RO	0b	Master Data Parity Error (PMDPE) Because the primary side of the PEG's virtual P2P bridge is integrated with the MCH functionality there is no scenario where this bit will get set. Because hardware will never set this bit, it is impossible for software to have an opportunity to clear this bit or otherwise test that it is implemented. The PCI specification defines it as a R/WC, but for our implementation an RO definition behaves the same way and will meet all Microsoft testing requirements. This bit can only be set when the Parity Error Enable bit in the PCI Command register is set.
7	RO	0b	Fast Back-to-Back (FB2B) Not Applicable or Implemented. Hardwired to 0.
6	RO	0b	Reserved
5	RO	0b	66/60MHz capability (CAP66) Not Applicable or Implemented. Hardwired to 0.
4	RO	1b	Capabilities List (CAPL) Indicates that a capabilities list is present. Hardwired to 1.
3	RO	0b	INTA Status (INTAS) Indicates that an interrupt message is pending internally to the device. Only PME and Hot Plug sources feed into this status bit (not PCI INTA-INTD assert and de-assert messages). The INTA Assertion Disable bit, PCICMD1[10], has no effect on this bit. Note that INTA emulation interrupts received across the link are not reflected in this bit.
2:0	RO	000b	Reserved



2.10.5 RID1—Revision Identification Register

This register contains the revision number of the processor device 1. These bits are read only and writes to this register have no effect.

This register contains the revision number of the processor. The Revision ID (RID) is a traditional 8-bit Read Only (RO) register located at offset 08h in the standard PCI header of every PCI/PCI Express compatible device and function.

B/D/F/Type:		0/1/0/PCI	
Address Offset:		8h	
Reset Value:		08h	
Access:		RO	
Bit	Attr	Reset Value	Description
7:0	RO	08h	Revision Identification Number (RID1) This is an 8-bit value that indicates the revision identification number for the processor Device 0. Refer to the <i>Intel® Core™ i5-600 and i3-500 Desktop Processor Series and Intel® Pentium® Desktop Processor 6000 Series Specification Update</i> for the value of the Revision ID Register.

2.10.6 CC1—Class Code Register

This register identifies the basic function of the device, a more specific sub-class, and a register- specific programming interface.

B/D/F/Type:		0/1/0/PCI	
Address Offset:		9–Bh	
Reset Value:		060400h	
Access:		RO	
Bit	Attr	Reset Value	Description
23:16	RO	06h	Base Class Code (BCC) Indicates the base class code for this device. This code has the value 06h, indicating a Bridge device.
15:8	RO	04h	Sub-Class Code (SUBCC) Indicates the sub-class code for this device. The code is 04h indicating a PCI to PCI Bridge.
7:0	RO	00h	Programming Interface (PI) Indicates the programming interface of this device. This value does not specify a particular register set layout and provides no practical use for this device.

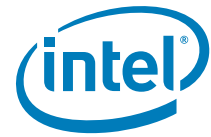

2.10.7 CL1—Cache Line Size Register

B/D/F/Type:		0/1/0/PCI	
Address Offset:		Ch	
Reset Value:		00h	
Access:		RW	
Bit	Attr	Reset Value	Description
7:0	RW	00h	Cache Line Size (Scratch pad) Implemented by PCI Express devices as a read-write field for legacy compatibility purposes but has no impact on any PCI Express device functionality.

2.10.8 HDR1—Header Type Register

This register identifies the header layout of the configuration space. No physical register exists at this location.

B/D/F/Type:		0/1/0/PCI	
Address Offset:		Eh	
Reset Value:		01h	
Access:		RO	
Bit	Attr	Reset Value	Description
7:0	RO	01h	Header Type Register (HDR) Returns 01 to indicate that this is a single function device with bridge header layout.

2.10.9 PBUSN1—Primary Bus Number Register

This register identifies that this "virtual" Host-PCI Express bridge is connected to PCI bus 0.

B/D/F/Type:		0/1/0/PCI	
Address Offset:		18h	
Reset Value:		00h	
Access:		RO	
Bit	Attr	Reset Value	Description
7:0	RO	00h	Primary Bus Number (BUSN) Configuration software typically programs this field with the number of the bus on the primary side of the bridge. Since device 1 is an internal device and its primary bus is always 0, these bits are read only and are hardwired to 0.



2.10.10 SBUSN1—Secondary Bus Number Register

This register identifies the bus number assigned to the second bus side of the "virtual" bridge (that is, to PCI Express-G). This number is programmed by the PCI configuration software to allow mapping of configuration cycles to PCI Express-G.

B/D/F/Type:		0/1/0/PCI	
Address Offset:		19h	
Reset Value:		00h	
Access:		RW	
Bit	Attr	Reset Value	Description
7:0	RW	00h	Secondary Bus Number (BUSN) This field is programmed by configuration software with the bus number assigned to PCI Express* G.

2.10.11 SUBUSN1—Subordinate Bus Number Register

This register identifies the subordinate bus (if any) that resides at the level below PCI Express-G. This number is programmed by the PCI configuration software to allow mapping of configuration cycles to PCI Express-G.

B/D/F/Type:		0/1/0/PCI	
Address Offset:		1Ah	
Reset Value:		00h	
Access:		RW	
Bit	Attr	Reset Value	Description
7:0	RW	00h	Subordinate Bus Number (BUSN) This register is programmed by configuration software with the number of the highest subordinate bus that lies behind the device 1 bridge. When only a single PCI device resides on the PCI Express-G segment, this register will contain the same value as the SBUSN1 register.



2.10.12 IOBASE1—I/O Base Address Register

This register controls the processor to PCI Express-G I/O access routing based on the following formula:

$$IO_BASE \leq address \leq IO_LIMIT$$

Only the upper 4 bits are programmable. For the purpose of address decode, address bits A[11:0] are treated as 0. Thus, the bottom of the defined I/O address range will be aligned to a 4 KB boundary.

B/D/F/Type: 0/1/0/PCI Address Offset: 1Ch Reset Value: F0h Access: RW, RO			
Bit	Attr	Reset Value	Description
7:4	RW	Fh	I/O Address Base (IOBASE) This field corresponds to A[15:12] of the I/O addresses passed by bridge 1 to PCI Express-G. BIOS must not set this register to 00h; otherwise, 0CF8h/0CFCh accesses will be forwarded to the PCI Express hierarchy associated with this device.
3:0	RO	0h	Reserved

2.10.13 IOLIMIT1—I/O Limit Address Register

This register controls the processor to PCI Express-G I/O access routing based on the following formula:

$$IO_BASE \leq address \leq IO_LIMIT$$

Only the upper 4 bits are programmable. For the purpose of address decode, address bits A[11:0] are assumed to be FFFh. Thus, the top of the defined I/O address range will be at the top of a 4 KB aligned address block.

B/D/F/Type: 0/1/0/PCI Address Offset: 1Dh Reset Value: 00h Access: RW, RO			
Bit	Attr	Reset Value	Description
7:4	RW	0h	I/O Address Limit (IOLIMIT) This field corresponds to A[15:12] of the I/O address limit of device 1. Devices between this upper limit and IOBASE1 will be passed to the PCI Express hierarchy associated with this device.
3:0	RO	0h	Reserved



2.10.14 SSTS1—Secondary Status Register

SSTS1 is a 16-bit status register that reports the occurrence of error conditions associated with secondary side (that is, PCI Express-G side) of the "virtual" PCI-PCI bridge embedded within processor.

B/D/F/Type:		0/1/0/PCI	
Address Offset:		1E–1Fh	
Reset Value:		0000h	
Access:		RW1C, RO	
Bit	Attr	Reset Value	Description
15	RW1C	0b	Detected Parity Error (DPE) This bit is set by the Secondary Side for a Type 1 Configuration Space header device whenever it receives a Poisoned TLP, regardless of the state of the Parity Error Response Enable bit in the Bridge Control Register.
14	RW1C	0b	Received System Error (RSE) This bit is set when the Secondary Side for a Type 1 configuration space header device receives an ERR_FATAL or ERR_NONFATAL.
13	RW1C	0b	Received Master Abort (RMA) This bit is set when the Secondary Side for Type 1 Configuration Space Header Device (for requests initiated by the Type 1 Header Device itself) receives a Completion with Unsupported Request Completion Status.
12	RW1C	0b	Received Target Abort (RTA) This bit is set when the Secondary Side for Type 1 Configuration Space Header Device (for requests initiated by the Type 1 Header Device itself) receives a Completion with Completer Abort Completion Status.
11	RO	0b	Signaled Target Abort (STA) Not Applicable or Implemented. Hardwired to 0. The processor does not generate Target Aborts (the processor will never complete a request using the Completer Abort Completion status).
10:9	RO	00b	DEVSELB Timing (DEVT) Not Applicable or Implemented. Hardwired to 0.
8	RW1C	0b	Master Data Parity Error (SMDPE) When set indicates that the MCH received across the link (upstream) a Read Data Completion Poisoned TLP (EP=1). This bit can only be set when the Parity Error Enable bit in the Bridge Control register is set.
7	RO	0b	Fast Back-to-Back (FB2B) Not Applicable or Implemented. Hardwired to 0.
6	RO	0b	Reserved
5	RO	0b	66/60 MHz capability (CAP66) Not Applicable or Implemented. Hardwired to 0.
4:0	RO	00h	Reserved



2.10.15 MBASE1—Memory Base Address Register

This register controls the processor to PCI Express-G non-prefetchable memory access routing based on the following formula:

$$\text{MEMORY_BASE} \leq \text{address} \leq \text{MEMORY_LIMIT}$$

The upper 12 bits of the register are read/write and correspond to the upper 12 address bits A[31:20] of the 32 bit address. The bottom 4 bits of this register are read-only and return zeroes when read. This register must be initialized by the configuration software. For the purpose of address decode, address bits A[19:0] are assumed to be 0. Thus, the bottom of the defined memory address range will be aligned to a 1 MB boundary.

B/D/F/Type:		0/1/0/PCI	
Address Offset:		20–21h	
Reset Value:		FFF0h	
Access:		RW, RO	
Bit	Attr	Reset Value	Description
15:4	RW	FFFh	Memory Address Base (MBASE) This field corresponds to A[31:20] of the lower limit of the memory range that will be passed to PCI Express-G.
3:0	RO	0h	Reserved



2.10.16 MLIMIT1—Memory Limit Address Register

This register controls the processor to PCI Express-G non-prefetchable memory access routing based on the following formula:

$$\text{MEMORY_BASE} \leq \text{address} \leq \text{MEMORY_LIMIT}$$

The upper 12 bits of the register are read/write and correspond to the upper 12 address bits A[31:20] of the 32 bit address. The bottom 4 bits of this register are read-only and return zeroes when read. This register must be initialized by the configuration software. For the purpose of address decode, address bits A[19:0] are assumed to be FFFFh. Thus, the top of the defined memory address range will be at the top of a 1 MB aligned memory block.

Note: Memory range covered by MBASE and MLIMIT registers are used to map non-prefetchable PCI Express-G address ranges (typically where control/status memory-mapped I/O data structures of the graphics controller will reside) and PMBASE and PMLIMIT are used to map prefetchable address ranges (typically graphics local memory). This segregation allows application of USWC space attribute to be performed in a true plug-and-play manner to the prefetchable address range for improved processor — PCI Express memory access performance.

Note: Configuration software is responsible for programming all address range registers (prefetchable, non-prefetchable) with the values that provide exclusive address ranges (that is, prevent overlap with each other and/or with the ranges covered with the main memory). There is no provision in the processor hardware to enforce prevention of overlap and operations of the system in the case of overlap are not ensured.

B/D/F/Type:		0/1/0/PCI	
Address Offset:		22–23h	
Reset Value:		0000h	
Access:		RW, RO	
Bit	Attr	Reset Value	Description
15:4	RW	000h	Memory Address Limit (MLIMIT) This field corresponds to A[31:20] of the upper limit of the address range passed to PCI Express-G.
3:0	RO	0h	Reserved

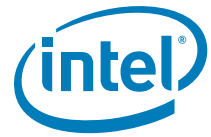

2.10.17 PMBASE1—Prefetchable Memory Base Address Register

This register in conjunction with the corresponding Upper Base Address register controls the processor to PCI Express-G prefetchable memory access routing based on the following formula:

$$\text{PREFETCHABLE_MEMORY_BASE} \leq \text{address} \leq \text{PREFETCHABLE_MEMORY_LIMIT}$$

The upper 12 bits of this register are read/write and correspond to address bits A[31:20] of the 40-bit address. The lower 8 bits of the Upper Base Address register are read/write and correspond to address bits A[39:32] of the 40-bit address. This register must be initialized by the configuration software. For the purpose of address decode, address bits A[19:0] are assumed to be 0. Thus, the bottom of the defined memory address range will be aligned to a 1 MB boundary.

B/D/F/Type:		0/1/0/PCI	
Address Offset:		24–25h	
Reset Value:		FFF1h	
Access:		RW, RO	
Bit	Attr	Reset Value	Description
15:4	RW	FFFh	Prefetchable Memory Base Address (MBASE) This field corresponds to A[31:20] of the lower limit of the memory range that will be passed to PCI Express-G.
3:0	RO	1h	64-bit Address Support (64-bit Address Support) This field indicates that the upper 32 bits of the prefetchable memory region base address are contained in the Prefetchable Memory base Upper Address register at 28h.



2.10.18 PMLIMIT1—Prefetchable Memory Limit Address Register

This register in conjunction with the corresponding Upper Limit Address register controls the processor to PCI Express-G prefetchable memory access routing based on the following formula:

$$\text{PREFETCHABLE_MEMORY_BASE} \leq \text{address} \leq \text{PREFETCHABLE_MEMORY_LIMIT}$$

The upper 12 bits of this register are read/write and correspond to address bits A[31:20] of the 40-bit address. The lower 8 bits of the Upper Limit Address register are read/write and correspond to address bits A[39:32] of the 40-bit address. This register must be initialized by the configuration software. For the purpose of address decode, address bits A[19:0] are assumed to be FFFFh. Thus, the top of the defined memory address range will be at the top of a 1 MB aligned memory block. Note that prefetchable memory range is supported to allow segregation by the configuration software between the memory ranges that must be defined as UC and the ones that can be designated as a USWC (that is, prefetchable) from the processor perspective.

B/D/F/Type:		0/1/0/PCI	
Address Offset:		26–27h	
Reset Value:		0001h	
Access:		RW, RO	
Bit	Attr	Reset Value	Description
15:4	RW	000h	Prefetchable Memory Address Limit (PMLIMIT) This field corresponds to A[31:20] of the upper limit of the address range passed to PCI Express-G.
3:0	RO	1h	64-bit Address Support This field indicates that the upper 32 bits of the prefetchable memory region limit address are contained in the Prefetchable Memory Base Limit Address register at 2Ch

2.10.19 PMBASEU1—Prefetchable Memory Base Address Upper Register

The functionality associated with this register is present in the PEG design implementation.

This register in conjunction with the corresponding Upper Base Address register controls the processor to PCI Express-G prefetchable memory access routing based on the following formula:

$$\text{PREFETCHABLE_MEMORY_BASE} \leq \text{address} \leq \text{PREFETCHABLE_MEMORY_LIMIT}$$

The upper 12 bits of this register are read/write and correspond to address bits A[31:20] of the 40-bit address. The lower 8 bits of the Upper Base Address register are read/write and correspond to address bits A[39:32] of the 40-bit address. This register must be initialized by the configuration software. For the purpose of address decode, address bits A[19:0] are assumed to be 0. Thus, the bottom of the defined memory address range will be aligned to a 1 MB boundary.

B/D/F/Type:		0/1/0/PCI	
Address Offset:		28–2Bh	
Reset Value:		0000_0000h	
Access:		RW	
Bit	Attr	Reset Value	Description
31:0	RW	0000_0000h	Prefetchable Memory Base Address (MBASEU) This field corresponds to A[63:32] of the lower limit of the prefetchable memory range that will be passed to PCI Express-G.



2.10.20 PMLIMITU1—Prefetchable Memory Limit Address Upper Register

The functionality associated with this register is present in the PEG design implementation.

This register in conjunction with the corresponding Upper Limit Address register controls the processor to PCI Express-G prefetchable memory access routing based on the following formula:

$$\text{PREFETCHABLE_MEMORY_BASE} \leq \text{address} \leq \text{PREFETCHABLE_MEMORY_LIMIT}$$

The upper 12 bits of this register are read/write and correspond to address bits A[31:20] of the 40-bit address. The lower 8 bits of the Upper Limit Address register are read/write and correspond to address bits A[39:32] of the 40-bit address. This register must be initialized by the configuration software. For the purpose of address decode, address bits A[19:0] are assumed to be FFFFh. Thus, the top of the defined memory address range will be at the top of a 1 MB aligned memory block.

Note that prefetchable memory range is supported to allow segregation by the configuration software between the memory ranges that must be defined as UC and the ones that can be designated as a USWC (that is, prefetchable) from the processor perspective.

B/D/F/Type:		0/1/0/PCI	
Address Offset:		2C–2Fh	
Reset Value:		0000_0000h	
Access:		RW	
Bit	Attr	Reset Value	Description
31:0	RW	0000_0000h	Prefetchable Memory Address Limit (MLIMITU) This field corresponds to A[63:32] of the upper limit of the prefetchable Memory range that will be passed to PCI Express-G.

2.10.21 CAPPTR1—Capabilities Pointer Register

The capabilities pointer provides the address offset to the location of the first entry in this device's linked list of capabilities.

B/D/F/Type:		0/1/0/PCI	
Address Offset:		34h	
Reset Value:		88h	
Access:		RO	
Bit	Attr	Reset Value	Description
7:0	RO	88h	First Capability (CAPPTR1) The first capability in the list is the Subsystem ID and Subsystem Vendor ID Capability.

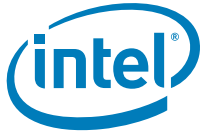

2.10.22 INTRLINE1—Interrupt Line Register

This register contains interrupt line routing information. The device itself does not use this value, rather it is used by device drivers and operating systems to determine priority and vector information.

B/D/F/Type:		0/1/0/PCI	
Address Offset:		3Ch	
Reset Value:		00h	
Access:		RW	
Bit	Attr	Reset Value	Description
7:0	RW	00h	Interrupt Connection (INTCON) This field is used to communicate interrupt line routing information. BIOS Requirement: POST software writes the routing information into this register as it initializes and configures the system. The value indicates to which input of the system interrupt controller this device's interrupt pin is connected.

2.10.23 INTRPIN1—Interrupt Pin Register

This register specifies which interrupt pin this device uses.

B/D/F/Type:		0/1/0/PCI	
Address Offset:		3Dh	
Reset Value:		01h	
Access:		RO	
Bit	Attr	Reset Value	Description
7:0	RO	01h	Interrupt Pin (INTPIN) As a single function device, the PCI Express device specifies INTA as its interrupt pin. 01h=INTA.

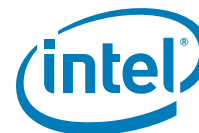

2.10.24 BCTRL1—Bridge Control Register

This register provides extensions to the PCICMD1 register that are specific to PCI-PCI bridges. The BCTRL provides additional control for the secondary interface (that is, PCI Express-G) as well as some bits that affect the overall behavior of the "virtual" Host-PCI Express bridge embedded within the processor, such as, VGA compatible address ranges mapping.

B/D/F/Type:		0/1/0/PCI	
Address Offset:		3E–3Fh	
Reset Value:		0000h	
Access:		RO, RW	
Bit	Attr	Reset Value	Description
15:12	RO	0h	Reserved
11	RO	0b	Discard Timer SERR# Enable (DTSERRE) Not Applicable or Implemented. Hardwired to 0.
10	RO	0b	Discard Timer Status (DTSTS) Not Applicable or Implemented. Hardwired to 0.
9	RO	0b	Secondary Discard Timer (SDT) Not Applicable or Implemented. Hardwired to 0.
8	RO	0b	Primary Discard Timer (PDT) Not Applicable or Implemented. Hardwired to 0.
7	RO	0b	Fast Back-to-Back Enable (FB2BEN) Not Applicable or Implemented. Hardwired to 0.
6	RW	0b	Secondary Bus Reset (SRESET) Setting this bit triggers a hot reset on the corresponding PCI Express Port. This will force the LTSSM to transition to the Hot Reset state (using Recovery) from L0, L0s, or L1 states.
5	RO	0b	Master Abort Mode (MAMODE) Does not apply to PCI Express. Hardwired to 0.
4	RW	0b	VGA 16-bit Decode (VGA16D) Enables the PCI-to-PCI bridge to provide 16-bit decoding of VGA I/O address precluding the decoding of alias addresses every 1 KB. This bit only has meaning if bit 3 (VGA Enable) of this register is also set to 1, enabling VGA I/O decoding and forwarding by the bridge. 0 = Execute 10-bit address decodes on VGA I/O accesses. 1 = Execute 16-bit address decodes on VGA I/O accesses.
3	RW	0b	VGA Enable (VGAEN) Controls the routing of processor initiated transactions targeting VGA compatible I/O and memory address ranges. See the VGAEN/MDAP table in device 0, offset 97h[0].
2	RW	0b	ISA Enable (ISAEN) Needed to exclude legacy resource decode to route ISA resources to legacy decode path. Modifies the response by the processor to an I/O access issued by the processor that target ISA I/O addresses. This applies only to I/O addresses that are enabled by the IOBASE and IOLIMIT registers. 0 = All addresses defined by the IOBASE and IOLIMIT for processor I/O transactions will be mapped to PCI Express-G. 1 = GMCH will not forward to PCI Express-G any I/O transactions addressing the last 768 bytes in each 1 KB block even if the addresses are within the range defined by the IOBASE and IOLIMIT registers.



B/D/F/Type:		0/1/0/PCI	
Address Offset:		3E–3Fh	
Reset Value:		0000h	
Access:		RO, RW	
Bit	Attr	Reset Value	Description
1	RW	0b	SERR Enable (SERREN) 0 = No forwarding of error messages from secondary side to primary side that could result in an SERR. 1 = ERR_COR, ERR_NONFATAL, and ERR_FATAL messages result in SERR message when individually enabled by the Root Control register.
0	RW	0b	Parity Error Response Enable (PEREN) Controls whether or not the Master Data Parity Error bit in the Secondary Status register is set when the MCH receives across the link (upstream) a Read Data Completion Poisoned TLP 0 = Master Data Parity Error bit in Secondary Status register can NOT be set. 1 = Master Data Parity Error bit in Secondary Status register CAN be set.

2.10.25 MSAC—Multi Size Aperture Control Register

This register determines the size of the graphics memory aperture in function 0 and in the trusted space. Only the system BIOS will write this register based on pre- boot address allocation efforts, but the graphics may read this register to determine the correct aperture size. System BIOS needs to save this value on boot so that it can reset it correctly during S3 resume.

B/D/F/Type:		0/2/0/PCI	
Address Offset:		62h	
Reset Value:		02h	
Access:		RO, RW, RW-K	
Bit	Attr	Reset Value	Description
7:4	RW	0h	Reserved: These RW bits are Scratch Bits Only. They have no physical effect on hardware.
3	RO	0b	Reserved
2:1	RW-K	01b	Untrusted Aperture Size (LHSAS) 11 = bits [28:27] of GMADR register are made Read only and forced to zero, allowing only 512 MB of GMADR 01 = bit [28] of GMADR is made R/W and bit [27] of GMADR is forced to zero allowing 256 MB of GMADR 00 = bits [28:27] of GMADR register are made RW allowing 128 MB of GMADR 10 = Invalid programming.
0	RO	0h	Reserved

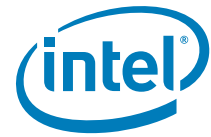

2.10.26 PM_CAPID1—Power Management Capabilities Register

B/D/F/Type:		0/1/0/PCI	
Address Offset:		80–83h	
Reset Value:		C8039001h	
Access:		RO	
Bit	Attr	Reset Value	Description
31:27	RO	19h	PME Support (PMES) This field indicates the power states in which this device may indicate PME wake using PCI Express messaging. D0, D3hot, and D3cold. This device is not required to do anything to support D3hot and D3cold, it simply must report that those states are supported. Refer to the PCI Power Management 1.1 specification for encoding explanation and other power management details.
26	RO	0b	D2 Power State Support (D2PSS) Hardwired to 0 to indicate that the D2 power management state is NOT supported.
25	RO	0b	D1 Power State Support (D1PSS) Hardwired to 0 to indicate that the D1 power management state is NOT supported.
24:22	RO	000b	Auxiliary Current (AUXC) Hardwired to 0 to indicate that there are no 3.3Vaux auxiliary current requirements.
21	RO	0b	Device Specific Initialization (DSI) Hardwired to 0 to indicate that special initialization of this device is NOT required before generic class device driver is to use it.
20	RO	0b	Auxiliary Power Source (APS) Hardwired to 0.
19	RO	0b	PME Clock (PMECLK) Hardwired to 0 to indicate this device does NOT support PMEB generation.
18:16	RO	011b	PCI PM CAP Version (PCI PMCV) Version — A value of 011b indicates that this function complies with revision 1.2 of the PCI Power Management Interface Specification.
15:8	RO	90h	Pointer to Next Capability (PNC) This contains a pointer to the next item in the capabilities list. If MSICH (CAPL[0] @ 7Fh) is 0, the next item in the capabilities list is the Message Signaled Interrupts (MSI) capability at 90h. If MSICH (CAPL[0] @ 7Fh) is 1, then the next item in the capabilities list is the PCI Express capability at A0h.
7:0	RO	01h	Capability ID (CID) Value of 01h identifies this linked list item (capability structure) as being for PCI Power Management registers.



2.10.27 PM_CS1—Power Management Control/Status Register

B/D/F/Type:		0/1/0/PCI	
Address Offset:		84–87h	
Reset Value:		0000_0008h	
Access:		RO, RW-S, RW	
Bit	Attr	Reset Value	Description
31:16	RO	0000h	Reserved Not Applicable or Implemented. Hardwired to 0.
15	RO	0b	PME Status (PMESTS) Indicates that this device does not support PMEB generation from D3cold.
14:13	RO	00b	Data Scale (DSCALE) Indicates that this device does not support the power management data register.
12:9	RO	0h	Data Select (DSEL) Indicates that this device does not support the power management data register.
8	RW-S	0b	PME Enable (PMEE) Indicates that this device does not generate PMEB assertion from any D-state. 0 = PMEB generation not possible from any D State 1 = PMEB generation enabled from any D State The setting of this bit has no effect on hardware. See PM_CAP[15:11]
7:4	RO	0000b	Reserved
3	RO	1b	No Soft Reset (NSR) When set to 1 this bit indicates that the device is transitioning from D3hot to D0 because the power state commands do not perform an internal reset. Config context is preserved. Upon transition no additional operating system intervention is required to preserve configuration context beyond writing the power state bits. When clear the devices do not perform an internal reset upon transitioning from D3hot to D0 using software control of the power state bits. Regardless of this bit, the devices that transition from a D3hot to D0 by a system or bus segment reset will return to the device state D0 uninitialized with only PME context preserved if PME is supported and enabled.
2	RO	0b	Reserved
1:0	RW	00b	Power State (PS) This field indicates the current power state of this device and can be used to set the device into a new power state. If software attempts to write an unsupported state to this field, write operation must complete normally on the bus, but the data is discarded and no state change occurs. 00 = D0 01 = D1 (Not supported in this device.) 10 = D2 (Not supported in this device.) 11 = D3 Support of D3cold does not require any special action. While in the D3hot state, this device can only act as the target of PCI configuration transactions (for power management control). This device also cannot generate interrupts or respond to MMR cycles in the D3 state. The device must return to the D0 state in order to be fully-functional. When the Power State is other than D0, the bridge will Master Abort (that is, not claim) any downstream cycles (with exception of type 0 config cycles). Consequently, these unclaimed cycles will go down DMI and come back up as Unsupported Requests, which the MCH logs as Master Aborts in Device 0 PCISTS[13]. There is no additional hardware functionality required to support these Power States.



2.10.28 SS_CAPID—Subsystem ID and Vendor ID Capabilities Register

This capability is used to uniquely identify the subsystem where the PCI device resides. Because this device is an integrated part of the system and not an add-in device, it is anticipated that this capability will never be used. However, it is necessary because Microsoft will test for its presence.

B/D/F/Type:		0/1/0/PCI	
Address Offset:		88–8Bh	
Reset Value:		0000800Dh	
Access:		RO	
Bit	Attr	Reset Value	Description
31:16	RO	0000h	Reserved
15:8	RO	80h	Pointer to Next Capability (PNC) This contains a pointer to the next item in the capabilities list which is the PCI Power Management capability.
7:0	RO	0Dh	Capability ID (CID) Value of 0Dh identifies this linked list item (capability structure) as being for SSID/SSVID registers in a PCI-to-PCI Bridge.

2.10.29 SS—Subsystem ID and Subsystem Vendor ID Register

System BIOS can be used as the mechanism for loading the SSID/SVID values. These values must be preserved through power management transitions and a hardware reset.

B/D/F/Type:		0/1/0/PCI	
Address Offset:		8C–8Fh	
Reset Value:		00008086h	
Access:		RW-O	
Bit	Attr	Reset Value	Description
31:16	RW-O	0000h	Subsystem ID (SSID) This field identifies the particular subsystem and is assigned by the vendor.
15:0	RW-O	8086h	Subsystem Vendor ID (SSVID) This field identifies the manufacturer of the subsystem and is the same as the vendor ID which is assigned by the PCI Special Interest Group.



2.10.30 MSI_CAPID—Message Signaled Interrupts Capability ID Register

When a device supports MSI, it can generate an interrupt request to the processor by writing a predefined data item (a message) to a predefined memory address.

The reporting of the existence of this capability can be disabled by setting MSICH (CAPL[0] @ 7Fh). In that case walking this linked list will skip this capability and instead go directly from the PCI PM capability to the PCI Express capability.

B/D/F/Type:		0/1/0/PCI	
Address Offset:		90–91h	
Reset Value:		A005h	
Access:		RO	
Bit	Attr	Reset Value	Description
15:8	RO	A0h	Pointer to Next Capability (PNC) This contains a pointer to the next item in the capabilities list which is the PCI Express capability.
7:0	RO	05h	Capability ID (CID) Value of 05h identifies this linked list item (capability structure) as being for MSI registers.

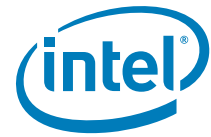

2.10.31 MC—Message Control Register

System software can modify bits in this register, but the device is prohibited from doing so.

If the device writes the same message multiple times, only one of those messages is ensured to be serviced. If all of them must be serviced, the device must not generate the same message again until the driver services the earlier one.

B/D/F/Type:		0/1/0/PCI	
Address Offset:		92–93h	
Reset Value:		0000h	
Access:		RO, RW	
Bit	Attr	Reset Value	Description
15:8	RO	00h	Reserved
7	RO	0b	64-bit Address Capable (64AC) Hardwired to 0 to indicate that the function does not implement the upper 32 bits of the Message Address register and is incapable of generating a 64-bit memory address. This may need to change in future implementations when addressable system memory exceeds the 32b/4 GB limit.
6:4	RW	000b	Multiple Message Enable (MME) System software programs this field to indicate the actual number of messages allocated to this device. This number will be equal to or less than the number actually requested. The encoding is the same as for the MMC field below.
3:1	RO	000b	Multiple Message Capable (MMC) System software reads this field to determine the number of messages being requested by this device. 000 = 1 All of the following are reserved in this implementation: 001 = 2 010 = 4 011 = 8 100 = 16 101 = 32 110 = Reserved 111 = Reserved
0	RW	0b	MSI Enable (MSIEN) This bit controls the ability of this device to generate MSIs. 0 = MSI will not be generated. 1 = MSI will be generated when we receive PME or HotPlug messages. INTA will not be generated and INTA Status (PCISTS1[3]) will not be set.



2.10.32 MA—Message Address Register

B/D/F/Type:		0/1/0/PCI	
Address Offset:		94–97h	
Reset Value:		0000_0000h	
Access:		RW, RO	
Bit	Attr	Reset Value	Description
31:2	RW	0000_0000h	Message Address (MA) This field is used by system software to assign an MSI address to the device. The device handles an MSI by writing the padded contents of the MD register to this address.
1:0	RO	00b	Force DWord Align (FDWA) Hardwired to 0 so that addresses assigned by system software are always aligned on a dword address boundary.

2.10.33 MD—Message Data Register

B/D/F/Type:		0/1/0/PCI	
Address Offset:		98–99h	
Reset Value:		0000h	
Access:		RW	
Bit	Attr	Reset Value	Description
15:0	RW	0000h	Message Data (MD) Base message data pattern assigned by system software and used to handle an MSI from the device. When the device must generate an interrupt request, it writes a 32-bit value to the memory address specified in the MA register. The upper 16 bits are always set to 0. The lower 16 bits are supplied by this register.

2.10.34 PEG_CAPL—PCI Express-G Capability List Register

This register enumerates the PCI Express capability structure.

B/D/F/Type:		0/1/0/PCI	
Address Offset:		A0–A1h	
Reset Value:		0010h	
Access:		RO	
Bit	Attr	Reset Value	Description
15:8	RO	00h	Pointer to Next Capability (PNC) This value terminates the capabilities list. The Virtual Channel capability and any other PCI Express specific capabilities that are reported using this mechanism are in a separate capabilities list located entirely within PCI Express Extended Configuration Space.
7:0	RO	10h	Capability ID (CID) Identifies this linked list item (capability structure) as being for PCI Express registers.

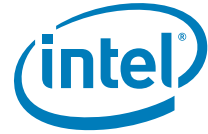

2.10.35 PEG_CAP—PCI Express-G Capabilities Register

This register indicates PCI Express device capabilities.

B/D/F/Type:		0/1/0/PCI	
Address Offset:		A2–A3h	
Reset Value:		0142h	
Access:		RO, RW-O	
Bit	Attr	Reset Value	Description
15	RO	0b	Reserved
14	RO	0b	Reserved: Reserved for TCS Routing Supported.
13:9	RO	00h	Interrupt Message Number (IMN) Not Applicable or Implemented. Hardwired to 0.
8	RW-O	1b	Slot Implemented (SI) 0 = The PCI Express Link associated with this port is connected to an integrated component or is disabled. 1 = The PCI Express Link associated with this port is connected to a slot. BIOS Requirement: This field must be initialized appropriately if a slot connection is not implemented.
7:4	RO	4h	Device/Port Type (DPT) Hardwired to 4h to indicate root port of PCI Express Root Complex.
3:0	RO	2h	PCI Express Capability Version (PCIECV) Hardwired to 2h to indicate compliance to the PCI Express Capabilities Register Expansion ECN.

2.10.36 DCAP—Device Capabilities Register

This register indicates PCI Express device capabilities.

B/D/F/Type:		0/1/0/PCI	
Address Offset:		A4–A7h	
Reset Value:		00008000h	
Access:		RO	
Bit	Attr	Reset Value	Description
31:16	RO	0000h	Reserved: Not Applicable or Implemented. Hardwired to 0.
15	RO	1b	Role Based Error Reporting (RBER) This bit indicates that this device implements the functionality defined in the Error Reporting ECN as required by the PCI Express 1.1 specification.
14:6	RO	000h	Reserved: Not Applicable or Implemented. Hardwired to 0.
5	RO	0b	Extended Tag Field Supported (ETFS) Hardwired to indicate support for 5-bit Tags as a Requestor.
4:3	RO	00b	Phantom Functions Supported (PFS) Not Applicable or Implemented. Hardwired to 0.
2:0	RO	000b	Max Payload Size (MPS) Hardwired to indicate 128B max supported payload for Transaction Layer Packets (TLP).



2.10.37 DCTL—Device Control Register

This register provides control for PCI Express device specific capabilities.

The error reporting enable bits are in reference to errors detected by this device, not error messages received across the link. The reporting of error messages (ERR_CORR, ERR_NONFATAL, ERR_FATAL) received by Root Port is controlled exclusively by Root Port Command Register.

B/D/F/Type:		0/1/0/PCI	
Address Offset:		A8–A9h	
Reset Value:		0000h	
Access:		RO, RW	
Bit	Attr	Reset Value	Description
15	RO	0h	Reserved
14:12	RO	000b	Reserved for Max Read Request Size (MRRS)
11	RO	0b	Reserved for Enable No Snoop
10	RO	0b	Reserved: Reserved for Auxiliary (AUX) PM Enable
9	RO	0b	Reserved: Reserved for Phantom Functions Enable
8	RO	0b	Reserved: Reserved for Extended Tag Field Enable
7:5	RW	000b	<p>Max Payload Size (MPS) 000 = 128B max supported payload for Transaction Layer Packets (TLP). As a receiver, the Device must handle TLPs as large as the set value; as transmitter, the Device must not generate TLPs exceeding the set value. All other encodings are reserved. Hardware will actually ignore this field. It is writeable only to support compliance testing.</p>
4	RO	0b	Reserved for Enable Relaxed Ordering
3	RW	0b	<p>Unsupported Request Reporting Enable (URRE) When set, this bit allows signaling ERR_NONFATAL, ERR_FATAL, or ERR_CORR to the Root Control register when detecting an unmasked Unsupported Request (UR). An ERR_CORR is signaled when an unmasked Advisory Non-Fatal UR is received. An ERR_FATAL or ERR_NONFATAL is sent to the Root Control register when an uncorrectable non-Advisory UR is received with the severity bit set in the Uncorrectable Error Severity register.</p>
2	RW	0b	<p>Fatal Error Reporting Enable (FERE) When set, this bit enables signaling of ERR_FATAL to the Root Control register due to internally detected errors or error messages received across the link. Other bits also control the full scope of related error reporting.</p>
1	RW	0b	<p>Non-Fatal Error Reporting Enable (NERE) When set, this bit enables signaling of ERR_NONFATAL to the Root Control register due to internally detected errors or error messages received across the link. Other bits also control the full scope of related error reporting.</p>
0	RW	0b	<p>Correctable Error Reporting Enable (CERE) When set, this bit enables signaling of ERR_CORR to the Root Control register due to internally detected errors or error messages received across the link. Other bits also control the full scope of related error reporting.</p>



2.10.38 DSTS—Device Status Register

This register reflects status corresponding to controls in the Device Control register. The error reporting bits are in reference to errors detected by this device, not errors messages received across the link.

B/D/F/Type:		0/1/0/PCI	
Address Offset:		AA–ABh	
Reset Value:		0000h	
Access:		RO, RW1C	
Bit	Attr	Reset Value	Description
15:6	RO	000h	Reserved and Zero: Reserved for future R/WC/S implementations; software must use 0 for writes to bits.
5	RO	0b	Transactions Pending (TP) 0 = All pending transactions (including completions for any outstanding non-posted requests on any used virtual channel) have been completed. 1 = Indicates that the device has transaction(s) pending (including completions for any outstanding non-posted requests for all used Traffic Classes).
4	RO	0b	Reserved
3	RW1C	0b	Unsupported Request Detected (URD) When set, this bit indicates that the Device received an Unsupported Request. Errors are logged in this register regardless of whether error reporting is enabled or not in the Device Control Register. Additionally, the Non-Fatal Error Detected bit or the Fatal Error Detected bit is set according to the setting of the Unsupported Request Error Severity bit. In production systems setting the Fatal Error Detected bit is not an option as support for AER will not be reported.
2	RW1C	0b	Fatal Error Detected (FED) When set, this bit indicates that fatal error(s) were detected. Errors are logged in this register regardless of whether error reporting is enabled or not in the Device Control register. When Advanced Error Handling is enabled, errors are logged in this register regardless of the settings of the uncorrectable error mask register.
1	RW1C	0b	Non-Fatal Error Detected (NFED) When set, this bit indicates that non-fatal error(s) were detected. Errors are logged in this register regardless of whether error reporting is enabled or not in the Device Control register. When Advanced Error Handling is enabled, errors are logged in this register regardless of the settings of the uncorrectable error mask register.
0	RW1C	0b	Correctable Error Detected (CED) When set, this bit indicates that correctable error(s) were detected. Errors are logged in this register regardless of whether error reporting is enabled or not in the Device Control register. When Advanced Error Handling is enabled, errors are logged in this register regardless of the settings of the correctable error mask register.



2.10.39 LCAP—Link Capabilities Register

This register indicates PCI Express device specific capabilities.

B/D/F/Type:		0/1/0/PCI	
Address Offset:		AC-AFh	
Reset Value:		02214D02h	
Access:		RO, RW-O	
Bit	Attr	Reset Value	Description
31:24	RO	02h	Port Number (PN) This bit indicates the PCI Express port number for the given PCI Express link. Matches the value in Element Self Description[31:24].
23:22	RO	00b	Reserved
21	RO	1b	Reserved Link Bandwidth Notification Capability – A value of 1b indicates support for the Link Bandwidth Notification status and interrupt mechanisms. This capability is required for all Root Ports and Switch downstream ports supporting Links wider than x1 and/or multiple Link speeds. This field is not applicable and is reserved for Endpoint devices, PCI Express to PCI/PCI-X bridges, and Upstream Ports of Switches. Devices that do not implement the Link Bandwidth Notification capability must hardwire this bit to 0b.
20	RO	0b	Data Link Layer Link Active Reporting Capable (DLLARC) For a Downstream Port, this bit must be set to 1b if the component supports the optional capability of reporting the DL_Active state of the Data Link Control and Management State Machine. For a hot-plug capable Downstream Port (as indicated by the Hot-Plug Capable field of the Slot Capabilities register), this bit must be set to 1b. For Upstream Ports and components that do not support this optional capability, this bit must be hardwired to 0b.
19	RO	0b	Surprise Down Error Reporting Capable (SDERC) For a Downstream Port, this bit must be set to 1b if the component supports the optional capability of detecting and reporting a Surprise Down error condition. For Upstream Ports and components that do not support this optional capability, this bit must be hardwired to 0b.
18	RO	0b	Clock Power Management (CPM) A value of 1b in this bit indicates that the component tolerates the removal of any reference clock(s) when the link is in the L1 and L2/3 Ready link states. A value of 0b indicates the component does not have this capability and that reference clock(s) must not be removed in these link states. This capability is applicable only in form factors that support "clock request" (CLKREQ#) capability. For a multi-function device, each function indicates its capability independently. Power Management configuration software must only permit reference clock removal if all functions of the multifunction device indicate a 1b in this bit.
17:15	RW-O	010b	L1 Exit Latency (L1ELAT) This field indicates the length of time this Port requires to complete the transition from L1 to L0. The value 010 b indicates the range of 2 us to less than 4 us. BIOS Requirement: If this field is required to be any value other than the default, BIOS must initialize it accordingly. Both bytes of this register that contain a portion of this field must be written simultaneously in order to prevent an intermediate (and undesired) value from ever existing.

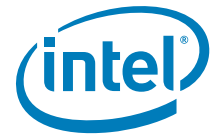

B/D/F/Type: 0/1/0/PCI Address Offset: AC-AFh Reset Value: 02214D02h Access: RO, RW-O			
Bit	Attr	Reset Value	Description
14:12	RO	100b	LOs Exit Latency (LOSELAT) This field indicates the length of time this Port requires to complete the transition from LOs to LO. 000 = Less than 64 ns 001 = 64ns to less than 128ns 010 = 128ns to less than 256 ns 011 = 256ns to less than 512ns 100 = 512ns to less than 1us 101 = 1 us to less than 2 us 110 = 2 us – 4 us 111 = More than 4 us The actual value of this field depends on the common Clock Configuration bit (LCTL[6]) and the Common and Non-Common clock LOs Exit Latency values in PEGLOSLAT (Offset 22Ch)
11:10	RW-O	11b	Active State Link PM Support (ASLPMS) Graphics Processing Engine supports ASPM L0s and L1.
9:4	RW-O	10h	Max Link Width (MLW) This field indicates the maximum number of lanes supported for this link.
3:0	RW-O	2h	Max Link Speed (MLS) Supported Link Speed – This field indicates the supported Link speed(s) of the associated Port. Defined encodings are: 0001b = 2.5GT/s Link speed supported 0010b = 5.0GT/s and 2.5GT/s Link speeds supported All other encodings are reserved.



2.10.40 CTL—Link Control Register

This register allows control of PCI Express link.

B/D/F/Type:		0/1/0/PCI	
Address Offset:		B0–B1h	
Reset Value:		0000h	
Access:		RO, RW, RW-SC	
Bit	Attr	Reset Value	Description
15:12	RO	0000b	Reserved
11	RW	0b	<p>Link Autonomous Bandwidth Interrupt Enable (LABIE) Link Autonomous Bandwidth Interrupt Enable – When Set, this bit enables the generation of an interrupt to indicate that the Link Autonomous Bandwidth Status bit has been Set. This bit is not applicable and is reserved for Endpoint devices, PCI Express to PCI/PCI-X bridges, and Upstream Ports of Switches. Devices that do not implement the Link Bandwidth Notification capability must hardwire this bit to 0b.</p>
10	RW	0b	<p>Link Bandwidth Management Interrupt Enable (LBMIE) Link Bandwidth Management Interrupt Enable – When Set, this bit enables the generation of an interrupt to indicate that the Link Bandwidth Management Status bit has been Set. This bit is not applicable and is reserved for Endpoint devices, PCI Express to PCI/PCI-X bridges, and Upstream Ports of Switches.</p>
9	RW	0b	<p>Hardware Autonomous Width Disable (HAWD) Hardware Autonomous Width Disable - When Set, this bit disables hardware from changing the Link width for reasons other than attempting to correct unreliable Link operation by reducing Link width. Devices that do not implement the ability autonomously to change Link width are permitted to hardwire this bit to 0b.</p>
8	RO	0b	<p>Enable Clock Power Management (ECPM) Applicable only for form factors that support a "Clock Request" (CLKREQ#) mechanism, this enable functions as follows: 0 = Clock power management is disabled and device must hold CLKREQ# signal low 1 = When this bit is set to 1 the device is permitted to use CLKREQ# signal to power manage link clock according to protocol defined in appropriate form factor specification. The Reset Value of this field is 0b. Components that do not support Clock Power Management (as indicated by a 0b value in the Clock Power Management bit of the Link Capabilities Register) must hardwire this bit to 0b.</p>
7	RW	0b	<p>Extended Synch (ES) 0 = Standard Fast Training Sequence (FTS). 1 = Forces the transmission of additional ordered sets when exiting the L0s state and when in the Recovery state. This mode provides external devices (such as, logic analyzers) monitoring the Link time to achieve bit and symbol lock before the link enters L0 and resumes communication. This is a test mode only and may cause other undesired side effects such as buffer overflows or underruns.</p>
6	RW	0b	<p>Common Clock Configuration (CCC) 0 = Indicates that this component and the component at the opposite end of this Link are operating with asynchronous reference clock. 1 = Indicates that this component and the component at the opposite end of this Link are operating with a distributed common reference clock. The state of this bit affects the L0s Exit Latency reported in LCAP[14:12] and the N_FTS value advertised during link training. See PEGLOSLAT at offset 22Ch.</p>

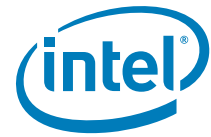

B/D/F/Type: Address Offset: Reset Value: Access:		0/1/0/PCI B0–B1h 0000h RO, RW, RW-SC	
Bit	Attr	Reset Value	Description
5	RW-SC	0b	Retrain Link (RL) 0 = Normal operation. 1 = Full Link retraining is initiated by directing the Physical Layer LTSSM from L0, L0s, or L1 states to the Recovery state. This bit always returns 0 when read. This bit is cleared automatically (no need to write a 0).
4	RW	0b	Link Disable (LD) 0 = Normal operation 1 = Link is disabled. Forces the LTSSM to transition to the Disabled state (using Recovery) from L0, L0s, or L1 states. Link retraining happens automatically on 0 to 1 transition, just like when coming out of reset. Writes to this bit are immediately reflected in the value read from the bit, regardless of actual Link state.
3	RO	0b	Read Completion Boundary (RCB) Hardwired to 0 to indicate 64 byte.
2	RO	0b	Reserved (FEDLB):
1:0	RW	00b	Active State PM (ASPM) This field controls the level of active state power management supported on the given link. 00 = Disabled 01 = L0s Entry Supported 10 = L1 Entry Enabled 11 = L0s and L1 Entry Supported Note: "L0s Entry Enabled" indicates the Transmitter entering L0s is supported. The Receiver must be capable of entering L0s even when the field is disabled (00b). ASPM L1 must be enabled by software in the Upstream component on a Link prior to enabling ASPM L1 in the Downstream component on that Link. When disabling ASPM L1, software must disable ASPM L1 in the Downstream component on a Link prior to disabling ASPM L1 in the Upstream component on that Link. ASPM L1 must only be enabled on the Downstream component if both components on a Link support ASPM L1.



2.10.41 LSTS—Link Status Register

This register indicates PCI Express link status.

B/D/F/Type:		0/1/0/PCI	
Address Offset:		B2–B3h	
Reset Value:		1000h	
Access:		RW1C, RO	
Bit	Attr	Reset Value	Description
15	RW1C	0b	<p>Link Autonomous Bandwidth Status (LABWS)</p> <p>This bit is set to 1b by hardware to indicate that hardware has autonomously changed link speed or width, without the port transitioning through DL_Down status, for reasons other than to attempt to correct unreliable link operation. This bit must be set if the Physical Layer reports a speed or width change was initiated by the downstream component that was indicated as an autonomous change.</p> <p>This bit must be set when the upstream component receives eight consecutive TS1 or TS2 ordered sets with the Autonomous Change bit set.</p>
14	RW1C	0b	<p>Link Bandwidth Management Status (LBWMS)</p> <p>This bit is set to 1b by hardware to indicate that either of the following has occurred without the port transitioning through DL_Down status:</p> <ul style="list-style-type: none"> A link retraining initiated by a write of 1b to the Retrain Link bit has completed. <p>Note: This bit is Set following any write of 1b to the Retrain Link bit, including when the Link is in the process of retraining for some other reason.</p> <ul style="list-style-type: none"> Hardware has autonomously changed link speed or width to attempt to correct unreliable link operation, either through an LTSSM time-out or a higher level process. <p>This bit must be set if the Physical Layer reports a speed or width change was initiated by the downstream component that was not indicated as an autonomous change.</p>
13	RO	0b	<p>Data Link Layer Link Active (Optional) (DLLLA)</p> <p>This bit indicates the status of the Data Link Control and Management State Machine. It returns a 1b to indicate the DL_Active state, 0b otherwise.</p> <p>This bit must be implemented if the corresponding Data Link Layer Active Capability bit is implemented. Otherwise, this bit must be hardwired to 0b.</p>
12	RO	1b	<p>Slot Clock Configuration (SCC)</p> <p>0 = The device uses an independent clock irrespective of the presence of a reference on the connector. 1 = The device uses the same physical reference clock that the platform provides on the connector.</p>
11	RO	0b	<p>Link Training (LTRN)</p> <p>This bit indicates that the Physical Layer LTSSM is in the Configuration or Recovery state, or that 1b was written to the Retrain Link bit but Link training has not yet begun. Hardware clears this bit when the LTSSM exits the Configuration/Recovery state once Link training is complete.</p>
10	RO	0b	<p>Undefined (Undefined)</p> <p>The value read from this bit is undefined. In previous versions of this specification, this bit was used to indicate a Link Training Error. System software must ignore the value read from this bit. System software is permitted to write any value to this bit.</p>



B/D/F/Type: 0/1/0/PCI Address Offset: B2–B3h Reset Value: 1000h Access: RW1C, RO			
Bit	Attr	Reset Value	Description
9:4	RO	00h	Negotiated Link Width (NLW) This field indicates negotiated link width. This field is valid only when the link is in the L0, L0s, or L1 states (after link width negotiation is successfully completed). 00h = Reserved 01h = X1 02h = X2 04h = X4 08h = X8 10h = X16 All other encodings are reserved.
3:0	RO	0h	Current Link Speed (CLS) This field indicates the negotiated Link speed of the given PCI Express Link. Defined encodings are: 0001b = 2.5 GT/s PCI Express Link 0010b = 5 GT/s PCI Express Link All other encodings are reserved. The value in this field is undefined when the Link is not up.



2.10.42 SLOTCAP—Slot Capabilities Register

Note: Hot Plug is not supported on the platform.

B/D/F/Type:		0/1/0/PCI	
Address Offset:		B4–B7h	
Reset Value:		00040000h	
Access:		RW-O, RO	
Bit	Attr	Reset Value	Description
31:19	RW-O	0000h	Physical Slot Number (PSN) Indicates the physical slot number attached to this Port. BIOS Requirement: This field must be initialized by BIOS to a value that assigns a slot number that is globally unique within the chassis.
18	RW-O	1b	No Command Completed Support (NCCS) When set to 1b, this bit indicates that this slot does not generate software notification when an issued command is completed by the Hot-Plug Controller. This bit is only permitted to be set to 1b if the hotplug capable port is able to accept writes to all fields of the Slot Control register without delay between successive writes.
17	RO	0b	Reserved for Electromechanical Interlock Present (EIP) When set to 1b, this bit indicates that an Electromechanical Interlock is implemented on the chassis for this slot.
16:15	RW-O	00b	Slot Power Limit Scale (SPLS) Specifies the scale used for the Slot Power Limit Value. 00 = 1.0x 01 = 0.1x 10 = 0.01x 11 = 0.001x If this field is written, the link sends a Set_Slot_Power_Limit message.
14:7	RW-O	00h	Slot Power Limit Value (SPLV) In combination with the Slot Power Limit Scale value, specifies the upper limit on power supplied by slot. Power limit (in Watts) is calculated by multiplying the value in this field by the value in the Slot Power Limit Scale field. If this field is written, the link sends a Set_Slot_Power_Limit message.
6	RO	0b	Reserved for Hot-plug Capable (HPC) When set to 1b, this bit indicates that this slot is capable of supporting hot-plug operations.
5	RO	0b	Reserved for Hot-plug Surprise (HPS) When set to 1b, this bit indicates that an adapter present in this slot might be removed from the system without any prior notification. This is a form factor specific capability. This bit is an indication to the operating system to allow for such removal without impacting continued software operation.
4	RO	0b	Reserved for Power Indicator Present (PIP) When set to 1b, this bit indicates that a Power Indicator is electrically controlled by the chassis for this slot.
3	RO	0b	Reserved for Attention Indicator Present (AIP) When set to 1b, this bit indicates that an Attention Indicator is electrically controlled by the chassis.
2	RO	0b	Reserved for MRL Sensor Present (MSP) When set to 1b, this bit indicates that an MRL Sensor is implemented on the chassis for this slot.
1	RO	0b	Reserved for Power Controller Present (PCP) When set to 1b, this bit indicates that a software programmable Power Controller is implemented for this slot/adaptor (depending on form factor).
0	RO	0b	Reserved for Attention Button Present (ABP) When set to 1b, this bit indicates that an Attention Button for this slot is electrically controlled by the chassis.



2.10.43 SLOTCTL—Slot Control Register

Note: Hot Plug is not supported on the platform.

B/D/F/Type:		0/1/0/PCI	
Address Offset:		B8–B9h	
Reset Value:		0000h	
Access:		RO, RW	
Bit	Attr	Reset Value	Description
15:13	RO	000b	Reserved
12	RO	0b	<p>Reserved for Data Link Layer State Changed Enable (DLLSCE)</p> <p>If the Data Link Layer Link Active capability is implemented, when set to 1b, this field enables software notification when Data Link Layer Link Active field is changed.</p> <p>If the Data Link Layer Link Active capability is not implemented, this bit is permitted to be read-only with a value of 0b.</p>
11	RO	0b	<p>Reserved for Electromechanical Interlock Control (EIC)</p> <p>If an Electromechanical Interlock is implemented, a write of 1b to this field causes the state of the interlock to toggle. A write of 0b to this field has no effect. A read to this register always returns a 0.</p>
10	RO	0b	<p>Reserved for Power Controller Control (PCC)</p> <p>If a Power Controller is implemented, this field when written sets the power state of the slot per the defined encodings. Reads of this field must reflect the value from the latest write, even if the corresponding hotplug command is not complete, unless software issues a write without waiting for the previous command to complete in which case the read value is undefined.</p> <p>Depending on the form factor, the power is turned on/off either to the slot or within the adapter. Note that in some cases the power controller may autonomously remove slot power or not respond to a power-up request based on a detected fault condition, independent of the Power Controller Control setting.</p> <p>The defined encodings are: 0b = Power On 1b = Power Off</p> <p>If the Power Controller Implemented field in the Slot Capabilities register is set to 0b, then writes to this field have no effect and the read value of this field is undefined.</p>
9:8	RO	00b	<p>Reserved Power Indicator Control (PIC)</p> <p>If a Power Indicator is implemented, writes to this field set the Power Indicator to the written state. Reads of this field must reflect the value from the latest write, even if the corresponding hot-plug command is not complete, unless software issues a write without waiting for the previous command to complete in which case the read value is undefined.</p> <p>00 = Reserved 01 = On 10 = Blink 11 = Off</p> <p>If the Power Indicator Present bit in the Slot Capabilities register is 0b, this field is permitted to be read-only with a value of 00b.</p>

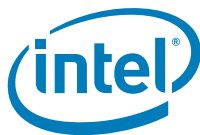

B/D/F/Type:		0/1/0/PCI	
Address Offset:		B8–B9h	
Reset Value:		0000h	
Access:		RO, RW	
Bit	Attr	Reset Value	Description
7:6	RO	00b	<p>Reserved for Attention Indicator Control (AIC) If an Attention Indicator is implemented, writes to this field set the Attention Indicator to the written state. Reads of this field must reflect the value from the latest write, even if the corresponding hot-plug command is not complete, unless software issues a write without waiting for the previous command to complete in which case the read value is undefined. If the indicator is electrically controlled by chassis, the indicator is controlled directly by the downstream port through implementation specific mechanisms. 00 = Reserved 01 = On 10 = Blink 11 = Off If the Attention Indicator Present bit in the Slot Capabilities register is 0b, this field is permitted to be read only with a value of 00b.</p>
5	RO	0b	<p>Reserved for Hot-plug Interrupt Enable (HPIE) When set to 1b, this bit enables generation of an interrupt on enabled hot-plug events The Reset Value of this field is 0b. If the Hot Plug Capable field in the Slot Capabilities register is set to 0b, this bit is permitted to be read-only with a value of 0b.</p>
4	RO	0b	<p>Reserved for Command Completed Interrupt Enable (CCI) If Command Completed notification is supported (as indicated by No Command Completed Support field of Slot Capabilities Register), when set to 1b, this bit enables software notification when a hot-plug command is completed by the Hot-Plug Controller. Reset Value of this field is 0b. If Command Completed notification is not supported, this bit must be hardwired to 0b.</p>
3	RW	0b	<p>Presence Detect Changed Enable (PDCE) When set to 1b, this bit enables software notification on a presence detect changed event.</p>
2	RO	0b	<p>Reserved for MRL Sensor Changed Enable (MSCE) When set to 1b, this bit enables software notification on a MRL sensor changed event. Reset Value of this field is 0b. If the MRL Sensor Present field in the Slot Capabilities register is set to 0b, this bit is permitted to be read-only with a value of 0b.</p>
1	RO	0b	<p>Reserved for Power Fault Detected Enable (PFDE) When set to 1b, this bit enables software notification on a power fault event. Reset Value of this field is 0b. If Power Fault detection is not supported, this bit is permitted to be read-only with a value of 0b</p>
0	RO	0b	<p>Reserved for Attention Button Pressed Enable (ABPE) When set to 1b, this bit enables software notification on an attention button pressed event.</p>



2.10.44 SLOTSTS—Slot Status Register

Note: Hot Plug is not supported on the platform.

B/D/F/Type:		O/1/O/PCI	
Address Offset:		BA–BBh	
Reset Value:		0000h	
Access:		RO, RW1C	
Bit	Attr	Reset Value	Description
15:9	RO	0000000b	Reserved and Zero: Reserved for future R/WC/S implementations; software must use 0 for writes to bits.
8	RO	0b	Reserved for Data Link Layer State Changed (DLLSC) This bit is set when the value reported in the Data Link Layer Link Active field of the Link Status register is changed. In response to a Data Link Layer State Changed event, software must read the Data Link Layer Link Active field of the Link Status register to determine if the link is active before initiating configuration cycles to the hot plugged device.
7	RO	0b	Reserved for Electromechanical Interlock Status (EIS) If an Electromechanical Interlock is implemented, this bit indicates the current status of the Electromechanical Interlock. Defined encodings are: 0 = Electromechanical Interlock Disengaged 1 = Electromechanical Interlock Engaged
6	RO	0b	Presence Detect State (PDS) This bit indicates the presence of an adapter in the slot, reflected by the logical "OR" of the Physical Layer in-band presence detect mechanism and, if present, any out-of-band presence detect mechanism defined for the slot's corresponding form factor. Note that the in-band presence detect mechanism requires that power be applied to an adapter for its presence to be detected. Consequently, form factors that require a power controller for hot-plug must implement a physical pin presence detect mechanism. Defined encodings are: 0b = Slot Empty 1b = Card Present in slot This register must be implemented on all Downstream Ports that implement slots. For Downstream Ports not connected to slots (where the Slot Implemented bit of the PCI Express Capabilities Register is 0b), this bit must return 1b.
5	RO	0b	Reserved for MRL Sensor State (MSS) This register reports the status of the MRL sensor if it is implemented. 0b = MRL Closed 1b = MRL Open
4	RO	0b	Reserved for Command Completed (CC) If Command Completed notification is supported (as indicated by No Command Completed Support field of Slot Capabilities Register), this bit is set when a hot-plug command has completed and the Hot-Plug Controller is ready to accept a subsequent command. The Command Completed status bit is set as an indication to host software that the Hot-Plug Controller has processed the previous command and is ready to receive the next command; it provides no assurance that the action corresponding to the command is complete. If Command Completed notification is not supported, this bit must be hardwired to 0b.
3	RW1C	0b	Presence Detect Changed (PDC) A pulse indication that the inband presence detect state has changed. This bit is set when the value reported in Presence Detect State is changed.



B/D/F/Type:		0/1/0/PCI	
Address Offset:		BA–BBh	
Reset Value:		0000h	
Access:		RO, RW1C	
Bit	Attr	Reset Value	Description
2	RO	0b	Reserved for MRL Sensor Changed (MSC) If an MRL sensor is implemented, this bit is set when a MRL Sensor state change is detected. If an MRL sensor is not implemented, this bit must not be set.
1	RO	0b	Reserved for Power Fault Detected (PFD) If a Power Controller that supports power fault detection is implemented, this bit is set when the Power Controller detects a power fault at this slot. Note that, depending on hardware capability, it is possible that a power fault can be detected at any time, independent of the Power Controller Control setting or the occupancy of the slot. If power fault detection is not supported, this bit must not be set.
0	RO	0b	Reserved for Attention Button Pressed (ABP) If an Attention Button is implemented, this bit is set when the attention button is pressed. If an Attention Button is not supported, this bit must not be set.

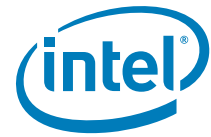

2.10.45 RCTL—Root Control Register

Allows control of PCI Express Root Complex specific parameters. The system error control bits in this register determine if corresponding SERRs are generated when our device detects an error (reported in this device's Device Status register) or when an error message is received across the link. Reporting of SERR as controlled by these bits takes precedence over the SERR Enable in the PCI Command Register.

B/D/F/Type:		0/1/0/PCI	
Address Offset:		BC–BDh	
Reset Value:		0000h	
Access:		RW, RO	
Bit	Attr	Reset Value	Description
15:5	RO	000h	Reserved
4	RO	0b	Reserved for CRS Software Visibility Enable (CSVE) This bit, when set, enables the Root Port to return Configuration Request Retry Status (CRS) Completion Status to software. Root Ports that do not implement this capability must hardwire this bit to 0b.
3	RW	0b	PME Interrupt Enable (PMEIE) 0 = No interrupts are generated as a result of receiving PME messages. 1 = Enables interrupt generation upon receipt of a PME message as reflected in the PME Status bit of the Root Status Register. A PME interrupt is also generated if the PME Status bit of the Root Status Register is set when this bit is set from a cleared state.
2	RW	0b	System Error on Fatal Error Enable (SEFEE) This bit controls the Root Complex's response to fatal errors. 0 = No SERR generated on receipt of fatal error. 1 = Indicates that an SERR should be generated if a fatal error is reported by any of the devices in the hierarchy associated with this Root Port, or by the Root Port itself.
1	RW	0b	System Error on Non-Fatal Uncorrectable Error Enable (SENFUEE) This bit controls the Root Complex's response to non-fatal errors. 0 = No SERR generated on receipt of non-fatal error. 1 = Indicates that an SERR should be generated if a non-fatal error is reported by any of the devices in the hierarchy associated with this Root Port, or by the Root Port itself.
0	RW	0b	System Error on Correctable Error Enable (SECEE) This bit controls the Root Complex's response to correctable errors. 0 = No SERR generated on receipt of correctable error. 1 = Indicates that an SERR should be generated if a correctable error is reported by any of the devices in the hierarchy associated with this Root Port, or by the Root Port itself.



2.10.46 RSTS—Root Status Register

This register provides information about PCI Express Root Complex specific parameters.

B/D/F/Type:		0/1/0/PCI	
Address Offset:		C0–C3h	
Reset Value:		0000_0000h	
Access:		RO, RW1C	
Bit	Attr	Reset Value	Description
31:18	RO	0000h	Reserved and Zero: Reserved for future R/WC/S implementations; software must use 0 for writes to bits.
17	RO	0b	PME Pending (PMEP) Indicates that another PME is pending when the PME Status bit is set. When the PME Status bit is cleared by software; the PME is delivered by hardware by setting the PME Status bit again and updating the Requestor ID appropriately. The PME pending bit is cleared by hardware if no more PMEs are pending.
16	RW1C	0b	PME Status (PMES) Indicates that PME was asserted by the requestor ID indicated in the PME Requestor ID field. Subsequent PMEs are kept pending until the status register is cleared by writing a 1 to this field.
15:0	RO	0000h	PME Requestor ID (PMERID) Indicates the PCI requestor ID of the last PME requestor.

2.10.47 LCTL2—Link Control 2 Register

B/D/F/Type:		0/1/0/PCI	
Address Offset:		D0–D1h	
Reset Value:		0002h	
Access:		RO, RW-S	
Bit	Attr	Reset Value	Description
15:13	RO	000	Reserved
12	RW-S	0b	Compliance De-emphasis (ComplianceDeemphasis) This bit sets the de-emphasis level in Polling.Compliance state if the entry occurred due to the Enter Compliance bit being 1b. 1 = 3.5 dB 0 = 6 dB When the link is operating at 2.5 GT/s, the setting of this bit has no effect. Components that support only 2.5 GT/s speed are permitted to hardwire this bit to 0b. For a multi-function device associated with an upstream port, the bit in Function 0 is of type RWS, and only Function 0 controls the component's link behavior. In all other functions of that device, this bit is of type RsvdP. The default value of this bit is 0b. This bit is intended for debug, compliance testing purposes. System firmware and software are allowed to modify this bit only during debug or compliance testing.
11:0	RO	002h	Reserved



2.10.48 LSTS2—Link Status 2 Register

B/D/F/Type:		0/1/0/PCI	
Address Offset:		D2–D3h	
Reset Value:		0000h	
Access:		RO	
Bit	Attr	Reset Value	Description
15:1	RO	0000h	Reserved
0	RO	0b	Current De-emphasis Level (CURDELVL) 1 = 3.5 dB 0 = 6 dB When the link is operating at 2.5 GT/s speed, this bit is 0b.

2.10.49 PEGLC—PCI Express* Legacy Control Register

This register controls functionality that is needed by Legacy (non-PCI Express aware) OS's during run time.

B/D/F/Type:		0/1/0/PCI	
Address Offset:		EC–EFh	
Reset Value:		0000_0000h	
Access:		RO, RW	
Bit	Attr	Reset Value	Description
31:3	RO	00000000h	Reserved
2	RW	0b	PME GPE Enable (PMEGPE) 0 = Do not generate GPE PME message when PME is received. 1 = Generate a GPE PME message when PME is received (Assert_PMEGPE and Deassert_PMEGPE messages on DMI). This enables the MCH to support PMEs on the PEG port under legacy OSs.
1	RW	0b	Hot-Plug GPE Enable (HPGPE) 0 = Do not generate GPE Hot-Plug message when Hot-Plug event is received. 1 = Generate a GPE Hot-Plug message when Hot-Plug Event is received (Assert_HPGPE and Deassert_HPGPE messages on DMI). This enables the MCH to support Hot-Plug on the PEG port under legacy OSs.
0	RW	0b	General Message GPE Enable (GENGPE) 0 = Do not forward received GPE assert/de-assert messages. 1 = Forward received GPE assert/de-assert messages. These general GPE message can be received using the PEG port from an external Intel device (that is, PxH) and will be subsequently forwarded to the PCH (using Assert_GPE and Deassert_GPE messages on DMI). For example, PxH might send this message if a PCI Express device is hot plugged into a PxH downstream port.



2.11 Device 1 Extended Configuration Registers

Table 2-8. Device 1 Extended Configuration Register Address Map

Address Offset	Register Symbol	Register Name	Reset Value	Access
100–103h	VCECH	Virtual Channel Enhanced Capability Header	00010002h	RW-O, RO
104–107h	PVCCAP1	Port VC Capability Register 1	0000_0000h	RO
108–10Bh	PVCCAP2	Port VC Capability Register 2	0000_0000h	RO
10C–10Dh	PVCCCTL	Port VC Control	0000h	RO, RW
110–113h	VCORCAP	VC0 Resource Capability	0000_0001h	RO
114–117h	VCORCTL	VC0 Resource Control	8000_00FFh	RO, RW
11A–11Bh	VCORSTS	VC0 Resource Status	0002h	RO,
204–207h	PEG_TC	PCI Express Completion Timeout	0000_0000h	RW

2.11.1 PVCCAP1—Port VC Capability Register 1

This register describes the configuration of PCI Express Virtual Channels associated with this port.

B/D/F/Type:		0/1/0/MMR	
Address Offset:		104–107h	
Reset Value:		0000_0000h	
Access:		RO	
Bit	Attr	Reset Value	Description
31:12	RO	00000h	Reserved
11:10	RO	00b	Reserved: Reserved for Port Arbitration Table Entry Size
9:8	RO	00b	Reserved: Reserved for Reference Clock
7	RO	0b	Reserved
6:4	RO	000b	Low Priority Extended VC Count (LPEVCC) This field indicates the number of (extended) Virtual Channels in addition to the default VC belonging to the low-priority VC (LPVC) group that has the lowest priority with respect to other VC resources in a strict-priority VC Arbitration. The value of 0 in this field implies strict VC arbitration.
3	RO	0b	Reserved
2:0	RO	000b	Extended VC Count (EVCC) This field indicates the number of (extended) Virtual Channels in addition to the default VC supported by the device.

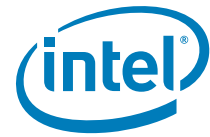

2.11.2 PVCCAP2—Port VC Capability Register 2

This register describes the configuration of PCI Express Virtual Channels associated with this port.

B/D/F/Type:		0/1/0/MMR	
Address Offset:		108–10Bh	
Reset Value:		0000_0000h	
Access:		RO	
Bit	Attr	Reset Value	Description
31:24	RO	00h	VC Arbitration Table Offset (VCATO) This field indicates the location of the VC Arbitration Table. This field contains the zero-based offset of the table in DQWORDS (16 bytes) from the base address of the Virtual Channel Capability Structure. A value of 0 indicates that the table is not present (due to fixed VC priority).
23:8	RO	0000h	Reserved
7:0	RO	00h	Reserved for VC Arbitration Capability (VCAC)

2.11.3 PVCCTL—Port VC Control Register

B/D/F/Type:		0/1/0/MMR	
Address Offset:		10C–10Dh	
Reset Value:		0000h	
Access:		RO, RW	
Bit	Attr	Reset Value	Description
15:4	RO	000h	Reserved
3:1	RW	000b	VC Arbitration Select (VCAS) This field will be programmed by software to the only possible value as indicated in the VC Arbitration Capability field. Since there is no other VC supported than the default, this field is reserved.
0	RO	0b	Reserved for Load VC Arbitration Table This bit is used for software to update the VC Arbitration Table when VC arbitration uses the VC Arbitration Table. As a VC Arbitration Table is never used by this component this field will never be used.



2.11.4 VCORCAP—VCO Resource Capability Register

B/D/F/Type:		0/1/0/MMR	
Address Offset:		110–113h	
Reset Value:		0000_0001h	
Access:		RO	
Bit	Attr	Reset Value	Description
31:24	RO	00h	Reserved for Port Arbitration Table Offset
23	RO	0b	Reserved
22:16	RO	00h	Reserved for Maximum Time Slots
15	RO	0b	Reject Snoop Transactions (RSNPT) 0 = Transactions with or without the No Snoop bit set within the TLP header are allowed on this VC. 1 = When Set, any transaction for which the No Snoop attribute is applicable but is not Set within the TLP Header will be rejected as an Unsupported Request
14:8	RO	00h	Reserved

2.11.5 VCORCTL—VCO Resource Control Register

This register controls the resources associated with PCI Express Virtual Channel 0.

B/D/F/Type:		0/1/0/MMR	
Address Offset:		114–117h	
Reset Value:		8000_00FFh	
Access:		RO, RW	
Bit	Attr	Reset Value	Description
31	RO	1b	VCO Enable (VCOE) For VCO, this is hardwired to 1 and read only as VCO can never be disabled.
30:27	RO	0h	Reserved
26:24	RO	000b	VCO ID (VCOID) This field assigns a VC ID to the VC resource. For VCO this is hardwired to 0 and read only.
23:20	RO	0h	Reserved
19:17	RW	000b	Port Arbitration Select (PAS) This field configures the VC resource to provide a particular Port Arbitration service. This field is valid for RCRBs, Root Ports that support peer to peer traffic, and Switch Ports, but not for PCI Express Endpoint devices or Root Ports that do not support peer to peer traffic. The permissible value of this field is a number corresponding to one of the asserted bits in the Port Arbitration Capability field of the VC resource.
16	RO	0b	Reserved: Reserved for Load Port Arbitration Table

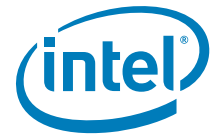

B/D/F/Type:		0/1/0/MMR	
Address Offset:		114–117h	
Reset Value:		8000_00FFh	
Access:		RO, RW	
Bit	Attr	Reset Value	Description
15:8	RO	00h	Reserved
7:1	RW	7Fh	TC/VCO Map (TCVCOM) This field indicates the TCs (Traffic Classes) that are mapped to the VC resource. Bit locations within this field correspond to TC values. For example, when bit 7 is set in this field, TC7 is mapped to this VC resource. When more than one bit in this field is set, it indicates that multiple TCs are mapped to the VC resource. In order to remove one or more TCs from the TC/VC Map of an enabled VC, software must ensure that no new or outstanding transactions with the TC labels are targeted at the given Link.
0	RO	1b	TC0/VCO Map (TC0VCOM) Traffic Class 0 is always routed to VCO.

2.11.6 VCORSTS—VCO Resource Status Register

This register reports the Virtual Channel specific status.

B/D/F/Type:		0/1/0/MMR	
Address Offset:		11A–11Bh	
Reset Value:		0002h	
Access:		RO	
Bit	Attr	Reset Value	Description
15:2	RO	0000h	Reserved and Zero
1	RO	1b	VCO Negotiation Pending (VCONP) 0 = The VC negotiation is complete. 1 = The VC resource is still in the process of negotiation (initialization or disabling). This bit indicates the status of the process of Flow Control initialization. It is set by default on Reset, as well as whenever the corresponding Virtual Channel is Disabled or the Link is in the DL_Down state. It is cleared when the link successfully exits the FC_INIT2 state. Before using a Virtual Channel, software must check whether the VC Negotiation Pending fields for that Virtual Channel are cleared in both Components on a Link.
0	RO	0b	Reserved for Port Arbitration Table Status



2.11.7 PEG_TC—PCI Express Completion Timeout Register

This register reports PCI Express configuration control of PCI Express Completion Timeout related parameters that are not required by the PCI Express specification.

B/D/F/Type:		0/1/0/MMR	
Address Offset:		204h	
Reset Value:		0000_0C00h	
Access:		RW	
Bit	Attr	Reset Value	Description
31:12	RW	0000_0h	Reserved
11:12	RW	11b	PCI Express Completion Timeout (PEG_TC) This field determines the number of milliseconds the Transaction Layer will wait to receive an expected completion. To avoid hang conditions, the Transaction Layer will generate a dummy completion to the requestor if it does not receive the completion within this time period. 00 = Disable 01 = Reserved 10 = Reserved 11 = 48 ms - for normal operation (default)
9:0	RW	0_0000_0000b	Reserved

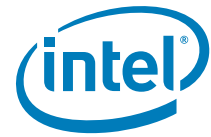

2.12 DMI BAR Registers

Table 2-9. DMI Register Address Map

Offset Address	Register Symbol	Register Name	Reset Value	Access
0–3h	DMIVCECH	DMI Virtual Channel Enhanced Capability	00010002h	RW-O, RO
4–7h	DMIPVCCAP1	DMI Port VC Capability Register 1	0000_0000h	RO, RW-O
8– Bh	DMIPVCCAP2	DMI Port VC Capability Register 2	0000_0000h	RO
C– Dh	DMIPVCCCTL	DMI Port VC Control	0000h	RO, RW
E– Fh	RSVD	Reserved	0h	RO
10–13h	DMIVC0RCAP	DMI VC0 Resource Capability	0000_0001h	RO
14–17h	DMIVC0RCTLO	DMI VC0 Resource Control	8000_00FFh	RW, RO
18–19h	RSVD	Reserved	0h	RO
1A–1Bh	DMIVC0RSTS	DMI VC0 Resource Status	0002h	RO
1C–1Fh	DMIVC1RCAP	DMI VC1 Resource Capability	00008001h	RO
20–23h	DMIVC1RCTL1	DMI VC1 Resource Control	0100_0000h	RO, RW
24–25h	RSVD	Reserved	0h	RO
26–27h	DMIVC1RSTS	DMI VC1 Resource Status	0002h	RO
84–87h	DMILCAP	DMI Link Capabilities	00012C41h	RO, RW-O
88–89h	DMILCTL	DMI Link Control	0000h	RO, RW
8A–8Bh	DMILSTS	DMI Link Status	0001h	RO

2.12.1 DMIVCECH—DMI Virtual Channel Enhanced Capability Register

This register indicates DMI Virtual Channel capabilities.

B/D/F/Type:		0/0/0/DMIBAR	
Address Offset:		0–3h	
Reset Value:		00010002h	
Access:		RW-O, RO	
Bit	Attr	Reset Value	Description
31:20	RW-O	000h	Pointer to Next Capability (PNC) This field contains the offset to the next PCI Express capability structure in the linked list of capabilities (Link Declaration Capability).
19:16	RO	1h	PCI Express Virtual Channel Capability Version (PCIEVCCV) Hardwired to 1 to indicate compliances with the 1.1 version of the PCI Express specification. Note: This version does not change for 2.0 compliance.
15:0	RO	0002h	Extended Capability ID (ECID) Value of 0002h identifies this linked list item (capability structure) as being for PCI Express Virtual Channel registers.



2.12.2 DMIPVCCAP1—DMI Port VC Capability Register 1

Describes the configuration of PCI Express Virtual Channels associated with this port.

B/D/F/Type:		0/0/0/DMIBAR	
Address Offset:		4–7h	
Reset Value:		0000_0000h	
Access:		RO, RW-O	
Bit	Attr	Reset Value	Description
31:7	RO	0000000h	Reserved
6:4	RO	000b	Low Priority Extended VC Count (LPEVCC) This field indicates the number of (extended) Virtual Channels in addition to the default VC belonging to the low-priority VC (LPVC) group that has the lowest priority with respect to other VC resources in a strict-priority VC Arbitration. The value of 0 in this field implies strict VC arbitration.
3	RO	0b	Reserved
2:0	RW-O	000b	Extended VC Count (EVCC) This field indicates the number of (extended) Virtual Channels in addition to the default VC supported by the device. For DMI, only the default Virtual Channel (VC0) is advertised in the Extended VC Capability structure.

2.12.3 DMIPVCCAP2—DMI Port VC Capability Register 2

This register describes the configuration of PCI Express Virtual Channels associated with this port.

B/D/F/Type:		0/0/0/DMIBAR	
Address Offset:		8–Bh	
Reset Value:		0000_0000h	
Access:		RO	
Bit	Attr	Reset Value	Description
31:24	RO	00h	Reserved for VC Arbitration Table Offset
23:8	RO	0000h	Reserved
7:0	RO	00h	Reserved for VC Arbitration Capability (VCAC)

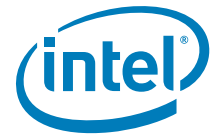

2.12.4 DMIPVCCTL—DMI Port VC Control Register

B/D/F/Type:		0/0/0/DMIBAR	
Address Offset:		C–Dh	
Reset Value:		0000h	
Access:		RO, RW	
Bit	Attr	Reset Value	Description
15:4	RO	000h	Reserved
3:1	RW	000b	VC Arbitration Select (VCAS) This field will be programmed by software to the only possible value as indicated in the VC Arbitration Capability field. The value 000b when written to this field will indicate the VC arbitration scheme is hardware fixed (in the root complex). This field cannot be modified when more than one VC in the LPVC group is enabled. 000 = Hardware fixed arbitration scheme. (such as, Round Robin) Others = Reserved See the PCI express specification for more details.
0	RO	0b	Reserved for Load VC Arbitration Table

2.12.5 DMIVCORCAP—DMI VCO Resource Capability Register

B/D/F/Type:		0/0/0/DMIBAR	
Address Offset:		10–13h	
Reset Value:		0000_0001h	
Access:		RO	
Bit	Attr	Reset Value	Description
31:24	RO	00h	Reserved for Port Arbitration Table Offset
23	RO	0b	Reserved
22:16	RO	00h	Reserved for Maximum Time Slots
15	RO	0b	Reject Snoop Transactions (REJSNPT) 0 = Transactions with or without the No Snoop bit set within the TLP header are allowed on this VC. 1 = Any transaction for which the No Snoop attribute is applicable but is not set within the TLP Header will be rejected as an Unsupported Request.
14:8	RO	00h	Reserved
7:0	RO	01h	Port Arbitration Capability (PAC) Having only bit 0 set indicates that the only supported arbitration scheme for this VC is non-configurable hardware-fixed.



2.12.6 DMI VCORCTLO—DMI VCO Resource Control Register

This register controls the resources associated with PCI Express Virtual Channel 0.

B/D/F/Type:		0/0/0/DMIBAR	
Address Offset:		14–17h	
Reset Value:		8000_00FFh	
Access:		RW, RO	
Bit	Attr	Reset Value	Description
31	RO	1b	Virtual Channel 0 Enable (VCOE) For VCO, this is hardwired to 1 and read only as VCO can never be disabled.
30:27	RO	0h	Reserved
26:24	RO	000b	Virtual Channel 0 ID (VCOID) Assigns a VC ID to the VC resource. For VCO this is hardwired to 0 and read only.
23:20	RO	0h	Reserved
19:17	RW	000b	Port Arbitration Select (PAS) This field configures the VC resource to provide a particular Port Arbitration service. Valid value for this field is a number corresponding to one of the asserted bits in the Port Arbitration Capability field of the VC resource. Because only bit 0 of that field is asserted. This field will always be programmed to 1.
16:8	RO	000h	Reserved
7:1	RW	7Fh	Traffic Class / Virtual Channel 0 Map (TCVCOM) This field indicates the TCs (Traffic Classes) that are mapped to the VC resource. Bit locations within this field correspond to TC values. For example, when bit 7 is set in this field, TC7 is mapped to this VC resource. When more than one bit in this field is set, it indicates that multiple TCs are mapped to the VC resource. In order to remove one or more TCs from the TC/VC Map of an enabled VC, software must ensure that no new or outstanding transactions with the TC labels are targeted at the given Link.
0	RO	1b	Traffic Class 0 / Virtual Channel 0 Map (TCOVCOM) Traffic Class 0 is always routed to VCO.



2.12.7 DMIVCORSTS—DMI VCO Resource Status Register

This register reports the Virtual Channel specific status.

B/D/F/Type:		0/0/0/DMIBAR	
Address Offset:		1A–1Bh	
Reset Value:		0002h	
Access:		RO	
Bit	Attr	Reset Value	Description
15:2	RO	0000h	Reserved: Reserved and Zero for future R/WC/S implementations. Software must use 0 for writes to these bits.
1	RO	1b	<p>Virtual Channel 0 Negotiation Pending (VCONP)</p> <p>0 = The VC negotiation is complete. 1 = The VC resource is still in the process of negotiation (initialization or disabling).</p> <p>This bit indicates the status of the process of Flow Control initialization. It is set by default on Reset, as well as whenever the corresponding Virtual Channel is Disabled or the Link is in the DL_Down state. It is cleared when the link successfully exits the FC_INIT2 state.</p> <p>BIOS Requirement: Before using a Virtual Channel, software must check whether the VC Negotiation Pending fields for that Virtual Channel are cleared in both Components on a Link.</p>
0	RO	0b	Reserved

2.12.8 DMIVC1RCAP—DMI VC1 Resource Capability Register

B/D/F/Type:		0/0/0/DMIBAR	
Address Offset:		1C–1Fh	
Reset Value:		00008001h	
Access:		RO	
Bit	Attr	Reset Value	Description
31:24	RO	00h	Reserved for Port Arbitration Table Offset
23	RO	0b	Reserved
22:16	RO	00h	Reserved for Maximum Time Slots
15	RO	1b	<p>Reject Snoop Transactions (REJSNPT)</p> <p>0 = Transactions with or without the No Snoop bit set within the TLP header are allowed on this VC. 1 = When Set, any transaction for which the No Snoop attribute is applicable but is not Set within the TLP Header will be rejected as an Unsupported Request.</p>
14:8	RO	00h	Reserved
7:0	RO	01h	<p>Port Arbitration Capability (PAC)</p> <p>Having only bit 0 set indicates that the only supported arbitration scheme for this VC is non-configurable hardware-fixed.</p>



2.12.9 DMI VC1RCTL1—DMI VC1 Resource Control Register

This register controls the resources associated with PCI Express Virtual Channel 1.

B/D/F/Type:		0/0/0/DMIBAR	
Address Offset:		20–23h	
Reset Value:		0100_0000h	
Access:		RO, RW	
Bit	Attr	Reset Value	Description
31	RW	0b	<p>Virtual Channel Enable (VCE) 0 = Virtual Channel is disabled. 1 = Virtual Channel is enabled. See exceptions below. Software must use the VC Negotiation Pending bit to check whether the VC negotiation is complete. When VC Negotiation Pending bit is cleared, a 1 read from this VC Enable bit indicates that the VC is enabled (Flow Control Initialization is completed for the PCI Express port). A 0 read from this bit indicates that the Virtual Channel is currently disabled.</p> <p>BIOS Requirement:</p> <ol style="list-style-type: none"> To enable a Virtual Channel, the VC Enable bits for that Virtual Channel must be set in both Components on a Link. To disable a Virtual Channel, the VC Enable bits for that Virtual Channel must be cleared in both Components on a Link. Software must ensure that no traffic is using a Virtual Channel at the time it is disabled. Software must fully disable a Virtual Channel in both Components on a Link before re-enabling the Virtual Channel.
30:27	RO	0h	Reserved
26:24	RW	001b	<p>Virtual Channel ID (VCID) Assigns a VC ID to the VC resource. Assigned value must be non-zero. This field can not be modified when the VC is already enabled.</p>
23:20	RO	0h	Reserved
19:17	RW	000b	<p>Port Arbitration Select (PAS) This field configures the VC resource to provide a particular Port Arbitration service. Valid value for this field is a number corresponding to one of the asserted bits in the Port Arbitration Capability field of the VC resource.</p>
16:8	RO	000h	Reserved
7:1	RW	00h	<p>Traffic Class / Virtual Channel Map (TCVCM) Indicates the TCs (Traffic Classes) that are mapped to the VC resource. Bit locations within this field correspond to TC values. For example, when bit 7 is set in this field, TC7 is mapped to this VC resource. When more than one bit in this field is set, it indicates that multiple TCs are mapped to the VC resource. In order to remove one or more TCs from the TC/VC Map of an enabled VC, software must ensure that no new or outstanding transactions with the TC labels are targeted at the given Link.</p> <p>BIOS Requirement: Program this field, including bit 0, with the value 00100010b (22h), which maps TC1 and TC5 to VC1.</p>
0	RO	0b	<p>Traffic Class 0 / Virtual Channel 1 Map (TC0VC1M) Traffic Class 0 is always routed to VC0.</p>



2.12.10 DMIVC1RSTS—DMI VC1 Resource Status Register

This register reports the Virtual Channel specific status.

B/D/F/Type:		0/0/0/DMIBAR	
Address Offset:		26–27h	
Reset Value:		0002h	
Access:		RO	
Bit	Attr	Reset Value	Description
15:2	RO	0000h	Reserved
1	RO	1b	<p>Virtual Channel 1 Negotiation Pending (VC1NP)</p> <p>0 = The VC negotiation is complete. 1 = The VC resource is still in the process of negotiation (initialization or disabling).</p> <p>Software may use this bit when enabling or disabling the VC. This bit indicates the status of the process of Flow Control initialization. It is set by default on Reset, as well as whenever the corresponding Virtual Channel is Disabled or the Link is in the DL_Down state. It is cleared when the link successfully exits the FC_INIT2 state.</p> <p>Before using a Virtual Channel, software must check whether the VC Negotiation Pending fields for that Virtual Channel are cleared in both Components on a Link.</p>
0	RO	0b	Reserved



2.12.11 DMI VCPCTL—DMI VCp Resource Control Register

This register controls the resources associated with the DMI Private Channel.

B/D/F/Type:		0/0/0/DMIBAR	
Address Offset:		2C–2Fh	
Reset Value:		0000_0000h	
Access:		RW, RO	
Bit	Attr	Reset Value	Description
31	RW	0b	<p>Virtual Channel Enable (VCE) 0 = Virtual Channel is disabled. 1 = Virtual Channel is enabled. See exceptions below.</p> <p>Software must use the VC Negotiation Pending bit to check whether the VC negotiation is complete. When VC Negotiation Pending bit is cleared, a 1 read from this VC Enable bit indicates that the VC is enabled (Flow Control Initialization is completed for the PCI Express port). A 0 read from this bit indicates that the Virtual Channel is currently disabled.</p> <p>BIOS Requirement:</p> <ol style="list-style-type: none"> To enable a Virtual Channel, the VC Enable bits for that Virtual Channel must be set in both Components on a Link. To disable a Virtual Channel, the VC Enable bits for that Virtual Channel must be cleared in both Components on a Link. Software must ensure that no traffic is using a Virtual Channel at the time it is disabled. Software must fully disable a Virtual Channel in both Components on a Link before re-enabling the Virtual Channel.
30:27	RO	0h	Reserved
26:24	RW	010b	<p>Virtual Channel ID (VCID) Assigns a VC ID to the VC resource. This field can not be modified when the VC is already enabled.</p>
23:8	RO	0000h	Reserved
7:1	RW	00h	<p>Traffic Class / Virtual Channel Map (TCVCM) This field indicates the TCs that are mapped to the VC resource. This field is valid for all Functions.</p> <p>Bit locations within this field correspond to TC values. For example, when bit 7 is Set in this field, TC7 is mapped to this VC resource. When more than 1 bit in this field is set, it indicates that multiple TCs are mapped to the VC resource.</p> <p>To remove one or more TCs from the TC/VC Map of an enabled VC, software must ensure that no new or outstanding transactions with the TC labels are targeted at the given Link.</p> <p>BIOS Requirement: Program this field, including bit 0, with the value 01000100b, which maps TC2 and TC6 to VCp.</p>
0	RO	0b	<p>Traffic Class 0 / Virtual Channel Map (TCOVCM) Traffic Class 0 is always routed to VC0.</p>



2.12.12 DMIVCPRSTS—DMI VCp Resource Status Register

This register reports the Virtual Channel specific status.

B/D/F/Type:		0/0/0/DMIBAR	
Address Offset:		32–33h	
Reset Value:		0002h	
Access:		RO	
Bit	Attr	Reset Value	Description
15:2	RO	0000h	Reserved: Reserved and Zero for future R/WC/S implementations. Software must use 0 for writes to these bits.
1	RO	1b	<p>Virtual Channel private Negotiation Pending (VCPNP)</p> <p>0 = The VC negotiation is complete. 1 = The VC resource is still in the process of negotiation (initialization or disabling).</p> <p>Software may use this bit when enabling or disabling the VC. This bit indicates the status of the process of Flow Control initialization. It is set by default on Reset, as well as whenever the corresponding Virtual Channel is Disabled or the Link is in the DL_Down state. It is cleared when the link successfully exits the FC_INIT2 state.</p> <p>Before using a Virtual Channel, software must check whether the VC Negotiation Pending fields for that Virtual Channel are cleared in both Components on a Link.</p>
0	RO	0b	Reserved

2.12.13 DMIESD—DMI Element Self Description Register

This register provides information about the root complex element containing this Link Declaration Capability.

B/D/F/Type:		0/0/0/DMIBAR	
Address Offset:		44–47h	
Reset Value:		01000202h	
Access:		RO, RWO	
Bit	Attr	Reset Value	Description
31:24	RO	01h	<p>Port Number (PORTNUM)</p> <p>This field specifies the port number associated with this element with respect to the component that contains this element. This port number value is utilized by the egress port of the component to provide arbitration to this Root Complex Element.</p>
23:16	RW-O	00h	<p>Component ID (CID)</p> <p>This field identifies the physical component that contains this Root Complex Element.</p> <p>BIOS Requirement: Must be initialized according to guidelines in the PCI Express* Isochronous/Virtual Channel Support Hardware Programming Specification (HPS).</p>
15:8	RO	02h	<p>Number of Link Entries (NLE)</p> <p>This field indicates the number of link entries following the Element Self Description. This field reports 2 (one for the processor egress port to main memory and one to egress port belonging to PCH on other side of internal link).</p>
7:4	RO	0h	Reserved
3:0	RO	2h	<p>Element Type (ETYP)</p> <p>This field indicates the type of the Root Complex Element. Value of 2h represents an Internal Root Complex Link (DMI).</p>



2.12.14 DMILE1D—DMI Link Entry 1 Description Register

This register provides the first part of a Link Entry which declares an internal link to another Root Complex Element.

B/D/F/Type:		0/0/0/DMIBAR	
Address Offset:		50–53h	
Reset Value:		0000_0000h	
Access:		RWO, RO	
Bit	Attr	Reset Value	Description
31:24	RW-O	00h	Target Port Number (TPN) This field specifies the port number associated with the element targeted by this link entry (egress port of the PCH). The target port number is with respect to the component that contains this element as specified by the target component ID. This can be programmed by BIOS, but the Reset Value will likely be correct because the DMI RCRB in the PCH will likely be associated with the default egress port for the PCH meaning it will be assigned port number 0.
23:16	RW-O	00h	Target Component ID (TCID) This field identifies the physical component that is targeted by this link entry. BIOS Requirement: Must be initialized according to guidelines in the PCI Express* Isochronous/Virtual Channel Support Hardware Programming Specification (HPS).
15:2	RO	0000h	Reserved
1	RO	0b	Link Type (LTYP) This field indicates that the link points to memory-mapped space (for RCRB). The link address specifies the 64-bit base address of the target RCRB.
0	RW-O	0b	Link Valid (LV) 0 = Link Entry is not valid and will be ignored. 1 = Link Entry specifies a valid link.

2.12.15 DMILE1A—DMI Link Entry 1 Address Register

This field provides the second part of a Link Entry which declares an internal link to another Root Complex Element.

B/D/F/Type:		0/0/0/DMIBAR	
Address Offset:		58–5Fh	
Reset Value:		0000_0000_0000_0000h	
Access:		RO, RWO	
Bit	Attr	Reset Value	Description
63:36	RO	0000000h	Reserved: Reserved for Link Address high order bits.
35:12	RW-O	000000h	Link Address (LA) This field provides the memory mapped base address of the RCRB that is the target element (egress port of the PCH) for this link entry.
11:0	RO	000h	Reserved



2.12.16 DMILE2D—DMI Link Entry 2 Description Register

This register provides the first part of a Link Entry which declares an internal link to another Root Complex Element.

B/D/F/Type:		0/0/0/DMIBAR	
Address Offset:		60–63h	
Reset Value:		0000_0000h	
Access:		RO, RWO	
Bit	Attr	Reset Value	Description
31:24	RO	00h	Target Port Number (TPN) This field specifies the port number associated with the element targeted by this link entry (Egress Port). The target port number is with respect to the component that contains this element as specified by the target component ID.
23:16	RW-O	00h	Target Component ID (TCID) This field identifies the physical or logical component that is targeted by this link entry. BIOS Requirement: Must be initialized according to guidelines in the PCI Express* Isochronous/Virtual Channel Support Hardware Programming Specification (HPS).
15:2	RO	0000h	Reserved
1	RO	0b	Link Type (LTYP) This field indicates that the link points to memory-mapped space (for RCRB). The link address specifies the 64-bit base address of the target RCRB.
0	RW-O	0b	Link Valid (LV) 0 = Link Entry is not valid and will be ignored. 1 = Link Entry specifies a valid link.

2.12.17 DMILE2A—DMI Link Entry 2 Address Register

This register provides the second part of a Link Entry which declares an internal link to another Root Complex Element.

B/D/F/Type:		0/0/0/DMIBAR	
Address Offset:		68–6Fh	
Reset Value:		0000_0000_0000_0000h	
Access:		RO, RWO	
Bit	Attr	Reset Value	Description
63:36	RO	0000000h	Reserved: Reserved for Link Address high order bits.
35:12	RW-O	000000h	Link Address (LA) This field provides the memory mapped base address of the RCRB that is the target element (Egress Port) for this link entry.
11:0	RO	000h	Reserved



2.12.18 DMILCAP—DMI Link Capabilities Register

This field indicates DMI specific capabilities.

B/D/F/Type:		0/0/0/DMIBAR	
Address Offset:		84–87h	
Reset Value:		00012C41h	
Access:		RO, RW-O	
Bit	Attr	Reset Value	Description
31:18	RO	0000h	Reserved
17:15	RW-O	010b	<p>L1 Exit Latency (L1SELAT) This field indicates the length of time this Port requires to complete the transition from L1 to L0. The value 010b indicates the range of 2 μs to less than 4 μs. 000 = Less than 1 μs 001 = 1 μs to less than 2 μs 010 = 2 μs to less than 4 μs 011 = 4 μs to less than 8 μs 100 = 8 μs to less than 16 μs 101 = 16 μs to less than 32 μs 110 = 32 μs–64 μs 111 = More than 64 μs Both bytes of this register that contain a portion of this field must be written simultaneously in order to prevent an intermediate (and undesired) value from ever existing.</p>
14:12	RW-O	010b	<p>LOs Exit Latency (LOSELAT) This field indicates the length of time this Port requires to complete the transition from LOs to L0. 000 = Less than 64 ns 001 = 64 ns to less than 128 ns 010 = 128 ns to less than 256 ns 011 = 256 ns to less than 512 ns 100 = 512 ns to less than 1 μs 101 = 1 μs to less than 2 μs 110 = 2 μs–4 μs 111 = More than 4 μs</p>
11:10	RO	11b	<p>Active State Link PM Support (ASLPMS) L0s and L1 entry supported.</p>
9:4	RO	04h	<p>Max Link Width (MLW) This field indicates the maximum number of lanes supported for this link.</p>
3:0	RO	1h	<p>Max Link Speed (MLS) Hardwired to indicate 2.5 Gb/s.</p>



2.12.19 DMILCTL—DMI Link Control Register

This register allows control of DMI.

B/D/F/Type:		0/0/0/DMIBAR	
Address Offset:		88–89h	
Reset Value:		0000h	
Access:		RO, RW	
Bit	Attr	Reset Value	Description
15:8	RO	00h	Reserved
7	RW	0b	Extended Synch (EXTSYNC) 0 = Standard Fast Training Sequence (FTS). 1 = Forces the transmission of additional ordered sets when exiting the L0s state and when in the Recovery state. This mode provides external devices (such as, logic analyzers) monitoring the Link time to achieve bit and symbol lock before the link enters L0 and resumes communication. This is a test mode only and may cause other undesired side effects such as buffer overflows or underruns.
6:3	RO	0h	Reserved
2	RO	0b	Reserved
1:0	RW	00b	Active State Power Management Support (ASPMS) This field controls the level of active state power management supported on the given link. 00 = Disabled 01 = L0s Entry Supported 10 = L1 Entry Enabled 11 = L0s and L1 Entry Supported

2.12.20 DMILSTS—DMI Link Status Register

B/D/F/Type:		0/0/0/DMIBAR	
Address Offset:		8A–8Bh	
Reset Value:		0001h	
Access:		RO	
Bit	Attr	Reset Value	Description
15:10	RO	00h	Reserved
9:4	RO	00h	Negotiated Width (NWID) This field indicates negotiated link width. This field is valid only when the link is in the L0, L0s, or L1 states (after link width negotiation is successfully completed). 00h = Reserved 01h = X1 02h = X2 04h = X4 All other encodings are reserved.
3:0	RO	1h	Negotiated Speed (NSPD) This field indicates negotiated link speed. 1h = 2.5 Gb/s All other encodings are reserved.



2.13 PCI Device 2, Function 0 Registers

Table 2-10. PCI (Device 2, Function 0) Register Address Map

Address Offset	Register Symbol	Register Name	Reset Value	Access
0–1h	VID2	Vendor Identification	8086h	RO
2–3h	DID2	Device Identification	0042h	RO
4–5h	PCICMD2	PCI Command	0000h	RO, RW
6–7h	PCISTS2	PCI Status	0090h	RO
8h	RID2	Revision Identification	12h	RO
9–Bh	CC	Class Code	030000h	RO
Ch	CLS	Cache Line Size	00h	RO
Dh	MLT2	Master Latency Timer	00h	RO
Eh	HDR2	Header Type	00h	RO
10–17h	GTTMMADR	Graphics Translation Table, Memory Mapped Range Address	0000_0000_0000_0004h	RW, RO
18–1Fh	GMADR	Graphics Memory Range Address	0000_0000_0000_000Ch	RO, RW-L, RW
20–23h	IOBAR	I/O Base Address	0000_0001h	RO, RW
2C–2Dh	SVID2	Subsystem Vendor Identification	0000h	RW-O
2E–2Fh	SID2	Subsystem Identification	0000h	RW-O
30–33h	ROMADR	Video BIOS ROM Base Address	0000_0000h	RO
34h	CAPPOINT	Capabilities Pointer	90h	RO
3Dh	INTRPIN	Interrupt Pin	01h	RO
3Eh	MINGNT	Minimum Grant	00h	RO
3Fh	MAXLAT	Maximum Latency	00h	RO

2.13.1 VID2—Vendor Identification Register

This register combined with the Device Identification register uniquely identifies any PCI device.

B/D/F/Type: 0/2/0/PCI Address Offset: 0–1h Reset Value: 8086h Access: RO			
Bit	Attr	Reset Value	Description
15:0	RO	8086h	Vendor Identification Number (VID) PCI standard identification for Intel.



2.13.2 DID2—Device Identification Register

This register combined with the Vendor Identification register uniquely identifies any PCI device.

B/D/F/Type:		0/2/0/PCI	
Address Offset:		2–3h	
Reset Value:		0042h	
Access:		RO	
Bit	Attr	Reset Value	Description
15:0	RO	0042h	Device Identification Number (DID) This is a 16 bit value assigned to the processor Graphics device.

2.13.3 PCICMD2—PCI Command Register

This 16-bit register provides basic control over the IGD ability to respond to PCI cycles. The PCICMD Register in the IGD disables the IGD PCI compliant master accesses to main memory.

B/D/F/Type:		0/2/0/PCI	
Address Offset:		4–5h	
Reset Value:		0000h	
Access:		RO, RW	
Bit	Attr	Reset Value	Description
15:11	RO	00h	Reserved
10:10	RO	0h	Reserved
9	RO	0b	Fast Back-to-Back (FB2B) Not Implemented. Hardwired to 0.
8	RO	0b	SERR Enable (SERRE) Not Implemented. Hardwired to 0.
7	RO	0b	Address/Data Stepping Enable (ADSTEP) Not Implemented. Hardwired to 0.
6	RO	0b	Parity Error Enable (PERRE) Not Implemented. Hardwired to 0. Since the IGD belongs to the category of devices that does not corrupt programs or data in system memory or hard drives, the IGD ignores any parity error that it detects and continues with normal operation.
5	RO	0b	Video Palette Snooping (VPS) This bit is hardwired to 0 to disable snooping.
4	RO	0b	Memory Write and Invalidate Enable (MWIE) Hardwired to 0. The IGD does not support memory write and invalidate commands.
3	RO	0b	Special Cycle Enable (SCE) This bit is hardwired to 0. The IGD ignores Special cycles.
2	RW	0b	Bus Master Enable (BME) 0 = Disable IGD bus mastering. 1 = Enable the IGD to function as a PCI compliant master.
1	RW	0b	Memory Access Enable (MAE) This bit controls the IGD response to memory space accesses. 0 = Disable 1 = Enable
0	RW	0b	I/O Access Enable (IOAE) This bit controls the IGD response to I/O space accesses. 0 = Disable 1 = Enable



2.13.4 PCISTS2—PCI Status Register

PCISTS is a 16-bit status register that reports the occurrence of a PCI compliant master abort and PCI compliant target abort.

PCISTS also indicates the DEVSEL# timing that has been set by the IGD.

B/D/F/Type:		0/2/0/PCI	
Address Offset:		6–7h	
Reset Value:		0090h	
Access:		RO	
Bit	Attr	Reset Value	Description
15	RO	0b	Detected Parity Error (DPE) Since the IGD does not detect parity, this bit is always hardwired to 0.
14	RO	0b	Signaled System Error (SSE) The IGD never asserts SERR#, therefore this bit is hardwired to 0.
13	RO	0b	Received Master Abort Status (RMAS) The IGD never gets a Master Abort, therefore this bit is hardwired to 0.
12	RO	0b	Received Target Abort Status (RTAS) The IGD never gets a Target Abort, therefore this bit is hardwired to 0.
11	RO	0b	Signaled Target Abort Status (STAS) Hardwired to 0. The IGD does not use target abort semantics.
10:9	RO	00b	DEVSEL Timing (DEVT) Not applicable. These bits are hardwired to 00.
8	RO	0b	Master Data Parity Error Detected (DPD) Since Parity Error Response is hardwired to disabled (and the IGD does not do any parity detection), this bit is hardwired to 0.
7	RO	1b	Fast Back-to-Back (FB2B) Hardwired to 1. The IGD accepts fast back-to-back when the transactions are not to the same agent.
6	RO	0b	User Defined Format (UDF) Hardwired to 0.
5	RO	0b	66 MHz PCI Capable (66C) Not applicable. Hardwired to 0.
4	RO	1b	Capability List (CLIST) This bit is set to 1 to indicate that the register at 34h provides an offset into the function's PCI Configuration Space containing a pointer to the location of the first item in the list.
3	RO	0b	Interrupt Status (INTSTS) This bit reflects the state of the interrupt in the device. Only when the Interrupt Disable bit in the command register is a 0 and this Interrupt Status bit is a 1, will the devices INTx# signal be asserted.
2:0	RO	000b	Reserved



2.13.5 RID2—Revision Identification Register

This register contains the revision number for Device 2, Functions 0 and 1.

This register contains the revision number of the processor. The Revision ID (RID) is a traditional 8-bit Read Only (RO) register located at offset 08h in the standard PCI header of every PCI/PCI Express compatible device and function.

B/D/F/Type:		0/2/0/PCI	
Address Offset:		8h	
Reset Value:		08h	
Access:		RO	
Bit	Attr	Reset Value	Description
7:0	RO	08h	Revision Identification Number (RID) This is an 8-bit value that indicates the revision identification number for the processor Device 0. Refer to the <i>Intel® Core™ i5-600 and i3-500 Desktop Processor Series and Intel® Pentium® Desktop Processor 6000 Series Specification Update</i> for the value of the Revision ID Register.

2.13.6 CC—Class Code Register

This register contains the device programming interface information related to the Sub-Class Code and Base Class Code definition for the IGD. This register also contains the Base Class Code and the function sub-class in relation to the Base Class Code.

B/D/F/Type:		0/2/0/PCI	
Address Offset:		9-Bh	
Reset Value:		030000h	
Access:		RO	
Bit	Attr	Reset Value	Description
23:16	RO	03h	Base Class Code (BCC) This is an 8-bit value that indicates the base class code for the processor. This code has the value 03h, indicating a Display Controller. When MCHBAR offset 44 bit 31 is 0 this code has the value 03h, indicating a Display Controller. When MCHBAR offset 44 bit 31 is 1 this code has the value 04h, indicating a Multimedia Device.
15:8	RO	00h	Sub-Class Code (SUBCC) When MCHBAR offset 44 bit 31 is 0 this value will be determined based on Device 0 GGC register, GMS and IVD fields. 00h = VGA compatible 80h = Non VGA (GMS = "0000" or IVD = "1") When MCHBAR offset 44 bit 31 is 1 this value is 80h, indicating other multimedia device.
7:0	RO	00h	Programming Interface (PI) When MCHBAR offset 44 bit 31 is 0 this value is 00h, indicating a Display Controller. When MCHBAR offset 44 bit 31 is 1 this value is 00h, indicating a NOP.



2.13.7 CLS—Cache Line Size Register

The IGD does not support this register as a PCI slave.

B/D/F/Type:		0/2/0/PCI	
Address Offset:		Ch	
Reset Value:		00h	
Access:		RO	
Bit	Attr	Reset Value	Description
7:0	RO	00h	Cache Line Size (CLS) This field is hardwired to 0s. The IGD as a PCI compliant master does not use the Memory Write and Invalidate command and, in general, does not perform operations based on cache line size.

2.13.8 MLT2—Master Latency Timer Register

The IGD does not support the programmability of the master latency timer because it does not perform bursts.

B/D/F/Type:		0/2/0/PCI	
Address Offset:		Dh	
Reset Value:		00h	
Access:		RO	
Bit	Attr	Reset Value	Description
7:0	RO	00h	Master Latency Timer Count Value (MLTCV) Hardwired to 0s.

2.13.9 HDR2—Header Type Register

This register contains the Header Type of the IGD.

B/D/F/Type:		0/2/0/PCI	
Address Offset:		Eh	
Reset Value:		00h	
Access:		RO	
Bit	Attr	Reset Value	Description
7	RO	0b	Multi Function Status (MFUNC) Indicates if the device is a Multi-Function Device. The value is hardwired to 0 to indicate that this Internal Graphics Device is a single-function device.
6:0	RO	00h	Header Code (H) This is a 7-bit value that indicates the Header Code for the IGD. This code has the value 00h, indicating a type 0 configuration space format.

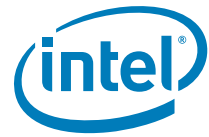

2.13.10 GTTMMADR—Graphics Translation Table, Memory Mapped Range Address Register

This register requests allocation for the combined Graphics Translation Table Modification Range and Memory Mapped Range. The range requires 4 MB combined for MMIO and Global GTT aperture, with 512K of that used by MMIO and 2MB used by GTT. GTTADR will begin at (GTTMMADR + 2 MB) while the MMIO base address will be the same as GTTMMADR.

For the Global GTT, this range is defined as a memory BAR in graphics device config space. It is an alias into which software is required to write Page Table Entry values (PTEs). Software may read PTE values from the global Graphics Translation Table (GTT). PTEs cannot be written directly into the global GTT memory area.

The device snoops writes to this region in order to invalidate any cached translations within the various TLBs implemented on-chip.

The allocation is for 4 MB and the base address is defined by bits [35:22].

B/D/F/Type:		0/2/0/PCI	
Address Offset:		10–17h	
Reset Value:		0000_0000_0000_0004h	
Access:		RW, RO	
Bit	Attr	Reset Value	Description
63:36	RW	0000000h	Reserved: Reserved for Memory Base Address Must be set to 0 since addressing above 64 GB is not supported.
35:22	RW	0000h	Memory Base Address (MBA) Set by the OS, these bits correspond to address signals [35:22]. 4 MB combined for MMIO and Global GTT table aperture (512 KB for MMIO and 2 MB for GTT).
21:4	RO	00000h	Reserved Hardwired to 0s to indicate at least 4 MB address range.
3	RO	0b	Prefetchable Memory (PREFMEM) Hardwired to 0 to prevent prefetching.
2:1	RO	10b	Memory Type (MENTYP) 00 = To indicate 32 bit base address 01 = Reserved 10 = To indicate 64 bit base address 11 = Reserved
0	RO	0b	Memory/IO Space (MIOS) Hardwired to 0 to indicate memory space.



2.13.11 GMADR—Graphics Memory Range Address Register

The IGD graphics memory base address is specified in this register.

Software must not change the value in MSAC[1:0] (offset 62h) after writing to the GMADR register.

B/D/F/Type:		0/2/0/PCI	
Address Offset:		18–1Fh	
Reset Value:		0000_0000_0000_000Ch	
Access:		RO, RW-L, RW	
Bit	Attr	Reset Value	Description
63:36	RW	0000000h	Memory Base Address (MBA2) Memory Base Address (MBA): Set by the OS, these bits correspond to address signals [63:36].
35:29	RW	0000000b	Memory Base Address (MBA) Memory Base Address (MBA): Set by the OS, these bits correspond to address signals [35:29].
28	RW-L	0b	512MB Address Mask (512ADMSK) This bit is either part of the Memory Base Address (R/W) or part of the Address Mask (RO), depending on the value of MSAC[2:1]. See MSAC (Dev2, Function 0, offset 62h) for details.
27	RW-L	0b	256 MB Address Mask (256ADMSK) This bit is either part of the Memory Base Address (R/W) or part of the Address Mask (RO), depending on the value of MSAC[2:1]. See MSAC (Device 2, Function 0, offset 62h) for details.
26:4	RO	000000h	Address Mask (ADM) Hardwired to 0s to indicate at least 128MB address range.
3	RO	1b	Prefetchable Memory (PREFMEM) Hardwired to 1 to enable prefetching.
2:1	RO	10b	Memory Type (MEMTYP) 00 = 32-bit address. 10 = 64-bit address
0	RO	0b	Memory/IO Space (MIOS) Hardwired to 0 to indicate memory space.



2.13.12 IOBAR—I/O Base Address Register

This register provides the Base offset of the I/O registers within Device 2. Bits 15:3 are programmable allowing the I/O Base to be located anywhere in 16bit I/O Address Space. Bits 2:1 are fixed and return zero, bit 0 is hardwired to a one indicating that 8 bytes of I/O space are decoded. Access to the 8Bs of IO space is allowed in PM state D0 when IO Enable (PCICMD bit 0) set. Access is disallowed in PM states D1–D3 or if IO Enable is clear or if Device 2 is turned off or if Internal graphics is disabled thru the fuse or fuse override mechanisms.

Note that access to this IO BAR is independent of VGA functionality within Device 2. Also note that this mechanism is available only through function 0 of Device 2 and is not duplicated in function 1.

If accesses to this IO bar are allowed, the processor claims all 8, 16, or 32 bit IO cycles from the processor that falls within the 8B claimed.

B/D/F/Type:		0/2/0/PCI	
Address Offset:		20–23h	
Reset Value:		0000_0001h	
Access:		RO, RW	
Bit	Attr	Reset Value	Description
31:16	RO	0000h	Reserved
15:3	RW	0000h	I/O Base Address (IOBASE) This field is set by the OS. The bits correspond to address signals [15:3].
2:1	RO	00b	Memory Type (MEMTYPE) Hardwired to 0s to indicate 32-bit address.
0	RO	1b	Memory/IO Space (MIOS) Hardwired to 1 to indicate I/O space.

2.13.13 SVID2—Subsystem Vendor Identification Register

B/D/F/Type:		0/2/0/PCI	
Address Offset:		2C–2Dh	
Reset Value:		0000h	
Access:		RW-O	
Bit	Attr	Reset Value	Description
15:0	RW-O	0000h	Subsystem Vendor ID (SUBVID) This value is used to identify the vendor of the subsystem. This register should be programmed by BIOS during boot-up. Once written, this register becomes Read Only. This register can only be cleared by a Reset.



2.13.14 SID2—Subsystem Identification Register

B/D/F/Type:		0/2/0/PCI	
Address Offset:		2E–2Fh	
Reset Value:		0000h	
Access:		RW-O	
Bit	Attr	Reset Value	Description
15:0	RW-O	0000h	Subsystem Identification (SUBID) This value is used to identify a particular subsystem. This field should be programmed by BIOS during boot-up. Once written, this register becomes Read Only. This register can only be cleared by a Reset.

2.13.15 ROMADR—Video BIOS ROM Base Address Register

The IGD does not use a separate BIOS ROM, therefore this register is hardwired to 0s.

B/D/F/Type:		0/2/0/PCI	
Address Offset:		30–33h	
Reset Value:		0000_0000h	
Access:		RO	
Bit	Attr	Reset Value	Description
31:18	RO	0000h	ROM Base Address (RBA) Hardwired to 0s.
17:11	RO	00h	Address Mask (ADMSK) Hardwired to 0s to indicate 256 KB address range.
10:1	RO	000h	Reserved Hardwired to 0s.
0	RO	0b	ROM BIOS Enable (RBE) 0 = ROM not accessible.

2.13.16 INTRPIN—Interrupt Pin Register

B/D/F/Type:		0/2/0/PCI	
Address Offset:		3Dh	
Reset Value:		01h	
Access:		RO	
Bit	Attr	Reset Value	Description
7:0	RO	01h	Interrupt Pin (INTPIN) As a single function device, the IGD specifies INTA# as its interrupt pin. 01h = INTA#.



2.13.17 MINGNT—Minimum Grant Register

B/D/F/Type:		0/2/0/PCI	
Address Offset:		3Eh	
Reset Value:		00h	
Access:		RO	
Bit	Attr	Reset Value	Description
7:0	RO	00h	Minimum Grant Value (MGV) The IGD does not burst as a PCI compliant master.

2.13.18 MAXLAT—Maximum Latency Register

B/D/F/Type:		0/2/0/PCI	
Address Offset:		3Fh	
Reset Value:		00h	
Access:		RO	
Bit	Attr	Reset Value	Description
7:0	RO	00h	Maximum Latency Value (MLV) The IGD has no specific requirements for how often it needs to access the PCI bus.

2.14 Device 2 I/O Registers

Address Offset	Register Symbol	Register Name	Reset Value	Access
0–3h	Index	MMIO Address Register	0000_0000h	RW
4–7h	Data	MMIO Data Register	0000_0000h	RW



2.14.1 Index—MMIO Address Register

A 32 bit I/O write to this port loads the offset of the MMIO register or offset into the GTT that needs to be accessed. An I/O Read returns the current value of this register. An 8/16 bit I/O write to this register is completed by the processor but does not update this register.

This mechanism to access internal graphics MMIO registers must not be used to access VGA IO registers which are mapped through the MMIO space. VGA registers must be accessed directly through the dedicated VGA I/O ports.

B/D/F/Type:		0/2/0/PCI IO	
Address Offset:		0–3h	
Reset Value:		0000_0000h	
Access:		RW	
Bit	Attr	Reset Value	Description
31:2	RW	00000000h	Register/GTT Offset (REGGTO) This field selects any one of the DWORD registers within the MMIO register space of Device 2 if the target is MMIO Registers. This field selects a GTT offset if the target is the GTT.
1:0	RO	0h	Reserved

2.14.2 Data—MMIO Data Register

A 32 bit IO write to this port is re-directed to the MMIO register/GTT location pointed to by the MMIO-index register. A 32 bit IO read to this port is re-directed to the MMIO register address pointed to by the MMIO-index register regardless of the target selection in MMIO_INDEX(1:0). 8 or 16 bit IO writes are completed by the processor and may have un-intended side effects, hence must not be used to access the data port. 8 or 16 bit IO reads are completed normally.

Note that if the target field in MMIO Index selects "GTT", reads to MMIO data return is undefined.

B/D/F/Type:		0/2/0/PCI IO	
Address Offset:		4–7h	
Reset Value:		0000_0000h	
Access:		RW	
Bit	Attr	Reset Value	Description
31:0	RW	00000000h	MMIO Data Window (DATA)



2.15 DMI and PEG VC0/VCp Remap Registers

Table 2-11. MMI and PEG VC0/VCp Remap Register Address Map (Sheet 1 of 2)

Address Offset	Register Symbol	Register Name	Reset Value	Access
0–3h	VER_REG	Version	0000_0010h	RO
8–Fh	CAP_REG	Capability	00C9008020630272h	RO
10–17h	ECAP_REG	Extended Capability	0000_0000_0000_1000h	RO
18–1Bh	GCMD_REG	Global Command	0000_0000h	W, WO, RO
1C–1Fh	GSTS_REG	Global Status	0000_0000h	RO
20–27h	RTADDR_REG	Root-Entry Table Address	00000_0000_0000_0_0000_0000h	RW, RO
28–2Fh	CCMD_REG	Context Command	0000_0000_0000_0000h	W, RW, RO,
34–37h	FSTS_REG	Fault Status	0000_0000h	RO, RO-V-S, RW1C-S
38–3Bh	FECTL_REG	Fault Event Control	8000_0000h	RW, RO
3C–3Fh	FEDATA_REG	Fault Event Data	0000_0000h	RO, RW
40–43h	FEADDR_REG	Fault Event Address	0000_0000h	RW, RO
44–47h	FEUADDR_REG	Fault Event Upper Address	0000_0000h	RO
58–5Fh	AFLOG_REG	Advanced Fault Log	0000_0000_0000_0000h	RO
64–67h	PMEM_REG	Protected Memory Enable	0000_0000h	RW, RO
68–6Bh	PLMBASE_REG	Protected Low-Memory Base	0000_0000h	RW, RO
6C–6Fh	PLMLIMIT_REG	Protected Low-Memory Limit	0000_0000h	RW, RO
70–77h	PHMBASE_REG	Protected High-Memory Base	0000_0000_0000_0000h	RW, RO
78–7Fh	PHMLIMIT_REG	Protected High-Memory Limit	0000_0000_0000_0000h	RW, RO
80–87h	IQH_REG	Invalidation Queue Head	0000_0000_0000_0000h	RO
88–8Fh	IQT_REG	Invalidation Queue Tail	0000_0000_0000_0000h	RO
90–97h	IQA_REG	Invalidation Queue Address	0000_0000_0000_0000h	RW, RO
9C–9Fh	ICS_REG	Invalidation Completion Status	0000_0000h	RO, RW1C-S
A0–A3h	IECTL_REG	Invalidation Event Control	0000_0000h	RW, RO
A4–A7h	IEDATA_REG	Invalidation Event Data	0000_0000h	RW
A8–ABh	IEADDR_REG	Invalidation Event Address	0000_0000h	RW, RO
AC–AFh	IEUADDR_REG	Invalidation Event Upper Address	0000_0000h	RW
B8–BFh	IRTA_REG	Interrupt Remapping Table Address	0000_0000_0000_0000h	RW, RO
100–107h	IVA_REG	Invalidate Address	0000_0000_0000_0000h	W, RO
108–10Fh	IOTLB_REG	IOTLB Invalidate	0000_0000_0000_0000h	RW, RO



Table 2-11. MMI and PEG VCO/VCp Remap Register Address Map (Sheet 2 of 2)

Address Offset	Register Symbol	Register Name	Reset Value	Access
200–20Fh	FRCD_REG	Fault Recording	0000_0000_0000_0000_0000_0000_0000_0000h	RW1C-S, RO-V-S, RO
F00–F03h	VTCMPRESR	VT Completion Resource Dedication	0006_0000h	RW-L, RO
F04–F07h	VTFTCHARBCTL	VCO/VCp VTd Fetch Arbiter Control	0000_FFFFh	RW-L
F08–F0Bh	PEGVTCP-PLRESR	PEG VT Completion Resource Dedication	2000_4000h	RW-L, RO
FFC–FFFh	VTPOLICY	DMA Remap Engine Policy Control	0000_0000h	RW-L

2.15.1 VER_REG—Version Register

This register reports the architecture version supported. Backward compatibility for the architecture is maintained with new revision numbers, allowing software to load DMA-remapping drivers written for prior architecture versions.

B/D/F/Type:		0/0/0/VCOPREMAP	
Address Offset:		0–3h	
Reset Value:		0000_0010h	
Access:		RO	
Bit	Attr	Reset Value	Description
31:8	RO	000000h	Reserved
7:4	RO	1h	Major Version number (MAX) Indicates supported architecture version.
3:0	RO	0h	Minor Version number (MIN) Indicates supported architecture minor version.



2.15.2 CAP_REG—Capability Register

This register reports general DMA remapping hardware capabilities.

B/D/F/Type:		0/0/0/VCOPREMAP	
Address Offset:		8–Fh	
Reset Value:		00C9008020630272h	
Access:		RO	
Bit	Attr	Reset Value	Description
63:56	RO	00h	Reserved
55	RO	1b	DMA Read Draining (DRD) 0 = On IOTLB invalidations, hardware does not support draining of translated DMA read requests queued within the root complex. 1 = On IOTLB invalidations, hardware supports draining of translated DMA read requests queued within the root complex. Indicates supported architecture version.
54	RO	1b	DMA Write Draining (DWD) 0 = On IOTLB invalidations, hardware does not support draining of translated DMA writes queued within the root complex. 1 = On IOTLB invalidations, hardware supports draining of translated DMA writes queued within the root complex.
53:48	RO	001001b	Maximum Address Mask Value (MAMV) The value in this field indicates the maximum supported value for the Address Mask (AM) field in the Invalidation Address (IVA_REG) register.
47:40	RO	00000000b	Number of Fault Recording Registers (NFR) This field indicates a value of N-1, where N is the number of fault recording registers supported by hardware. Implementations must support at least one fault recording register (NFR = 0) for each DMA-remapping hardware unit in the platform. The maximum number of fault recording registers per DMA-remapping hardware unit is 256. Bit 40 in the capability register is the least significant bit of the NFR field (47:40).
39	RO	1b	Page Selective Invalidation Support (PSI) 0 = DMAR engine does not support page selective invalidations 1 = DMAR engine does support page-selective IOTLB invalidations. The MAMV field indicates the maximum number of contiguous translations that may be invalidated in a single request.
38	RO	0b	Reserved
37:34	RO	0000b	Super Page Support (SPS) This field indicates the super page sizes supported by hardware. A value of 1 in any of these bits indicates the corresponding super-page size is supported. The super-page sizes corresponding to various bit positions within this field are: 0 = 21-bit offset to page frame 1 = 30-bit offset to page frame 2 = 39-bit offset to page frame 3 = 48-bit offset to page frame
33:24	RO	020h	Fault-recording Register offset (FRO) This field specifies the location to the first fault recording register relative to the register base address of this DMA-remapping hardware unit. If the register base address is X, and the value reported in this field is Y, the address for the first fault recording register is calculated as X+(16*Y).



B/D/F/Type: Address Offset: Reset Value: Access:		0/0/0/VCOPREMAP 8–Fh 00C9008020630272h RO	
Bit	Attr	Reset Value	Description
23	RO	0b	<p>Isynchrony (Isoch)</p> <p>0 = Indicates this DMA-remapping hardware unit has no critical isochronous requesters in its scope.</p> <p>1 = Indicates this DMA-remapping hardware unit has one or more critical isochronous requesters in its scope. To ensure isochronous performance, software must ensure invalidation operations do not impact active DMA streams. This implies that when DMA is active, software perform page-selective invalidations (instead of coarser invalidations).</p>
22	RO	1b	<p>Zero Length Read (ZLR)</p> <p>0 = Indicates the remapping hardware unit blocks (and treats as fault) zero length DMA read requests to write-only pages.</p> <p>1 = Indicates the remapping hardware unit supports zero length DMA read requests to write-only pages.</p>
21:16	RO	100011b	<p>Maximum Guest Address Width (MGAW)</p> <p>This field indicates the maximum DMA virtual addressability supported by remapping hardware.</p> <p>The Maximum Guest Address Width (MGAW) is computed as $(N+1)$, where N is the value reported in this field.</p> <p>For example, a hardware implementation supporting 48-bit MGAW reports a value of 47 (101111b) in this field.</p> <p>If the value in this field is X, DMA requests to addresses above $2(x+1)-1$ are always blocked by hardware. Guest addressability for a given DMA request is limited to the minimum of the value reported through this field and the adjusted guest address width of the corresponding page-table structure. (Adjusted guest address widths supported by hardware are reported through the SAGAW field).</p>
15:13	RO	000b	Reserved
12:8	RO	00010b	<p>Supported Adjusted Guest Address Widths (SAGAW)</p> <p>This 5-bit field indicates the supported adjusted guest address widths (which in turn represents the levels of page-table walks) supported by the hardware implementation.</p> <p>A value of 1 in any of these bits indicates the corresponding adjusted guest address width is supported. The adjusted guest address widths corresponding to various bit positions within this field are:</p> <p>0 = 30-bit AGAW (2-level page table) 1 = 39-bit AGAW (3-level page table) 2 = 48-bit AGAW (4-level page table) 3 = 57-bit AGAW (5-level page table) 4 = 64-bit AGAW (6-level page table)</p> <p>Software must ensure that the adjusted guest address width used to setup the page tables is one of the supported guest address widths reported in this field.</p>
7	RO	0b	<p>Caching Mode (CM)</p> <p>0 = Hardware does not cache not present and erroneous entries in the context-cache and IOTLB. Invalidations are not required for modifications to individual not present or invalid entries. However, any modifications that result in decreasing the effective permissions or partial permission increases require invalidations for them to be effective.</p> <p>1 = Hardware may cache not present and erroneous mappings in the context-cache or IOTLB. Any software updates to the DMA-remapping structures (including updates to not-present or erroneous entries) require explicit invalidation.</p> <p>Refer to the VTd specification for more details on caching mode.</p> <p>Hardware implementations are recommended to support operation corresponding to CM=0.</p>

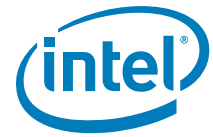

B/D/F/Type:		0/0/0/VCOPREMAP	
Address Offset:		8–Fh	
Reset Value:		00C9008020630272h	
Access:		RO	
Bit	Attr	Reset Value	Description
6	RO	1b	<p>Protected High-Memory Region (PHMR)</p> <p>0 = Indicates protected high-memory region not supported. 1 = Indicates protected high-memory region is supported.</p> <p>DMA-remapping hardware implementations on Intel TXT platforms supporting main memory above 4 GB are required to support protected high-memory region.</p>
5	RO	1b	<p>Protected Low-Memory Region (PLMR)</p> <p>0 = Indicates protected low-memory region not supported. 1 = Indicates protected low-memory region is supported.</p> <p>DMA-remapping hardware implementations on Intel TXT platforms are required to support protected low-memory region.</p>
4	RO	1b	<p>Required Write-Buffer Flushing (RWBF)</p> <p>0 = Indicates no write-buffer flushing needed to ensure changes to memory-resident structures are visible to hardware. 1 = Indicates software must explicitly flush the write buffers (through the Global Command register) to ensure updates made to memory-resident DMA-remapping structures are visible to hardware.</p> <p>Refer to the VTd specification for more details on write buffer flushing requirements.</p>
3	RO	0b	<p>Advanced Fault Logging (AFL)</p> <p>0 = Indicates advanced fault logging not supported. Only primary fault logging is supported. 1 = Indicates advanced fault logging is supported.</p>
2:0	RO	010b	<p>Number of domains supported (ND)</p> <p>000b = Hardware supports 4-bit domain-ids with support for up to 16 domains. 001b = Hardware supports 6-bit domain-ids with support for up to 64 domains. 010b = Hardware supports 8-bit domain-ids with support for up to 256 domains. 011b = Hardware supports 10-bit domain-ids with support for up to 1024 domains. 100b = Hardware supports 12-bit domain-ids with support for up to 4K domains. 101b = Hardware supports 14-bit domain-ids with support for up to 16K domains. 110b = Hardware supports 16-bit domain-ids with support for up to 64K domains. 111b = Reserved.</p>



2.15.3 ECAP_REG—Extended Capability Register

This register reports DMA-remapping hardware extended capabilities.

B/D/F/Type:		0/0/0/VCOPREMAP	
Address Offset:		10–17h	
Reset Value:		0000000000001000h	
Access:		RO	
Bit	Attr	Reset Value	Description
63:32	RO	00000000h	Reserved
31:24	RO	00h	Number of IOTLB Invalidation Units (NIU) This field indicates a value of N-1, where N is the number of IOTLB invalidation units supported by hardware. Each IOTLB invalidation unit consists of two registers: A 64-bit IOTLB Invalidation Register (IOTLB_REG), followed by a 64-bit Invalidation Address Register (IVA_REG). Implementations must support at least one IOTLB invalidation unit (NIVU = 0) for each DMA-remapping hardware unit in the platform. The maximum number of IOTLB invalidation register units per DMA-remapping hardware unit is 256.
23:20	RO	0000b	Maximum Handle Mask Value (MHMV) The value in this field indicates the maximum supported value for the Handle Mask (HM) field in the interrupt entry cache invalidation descriptor (iec_inv_dsc). This field is valid only when the IR field is reported as Set.
19:18	RO	00b	Reserved
17:8	RO	010h	Invalidation Unit Offset (IVO) This field specifies the location to the first IOTLB invalidation unit relative to the register base address of this DMA-remapping hardware unit. If the register base address is X, and the value reported in this field is Y, the address for the first IOTLB invalidation unit is calculated as X+(16*Y). If N is the value reported in NIU field, the address for the last IOTLB invalidation unit is calculated as X+(16*Y)+(16*N).
7	RO	0b	Snoop Control (SC) 0 = Hardware does not support 1-setting of the SNP field in the page-table entries. 1 = Hardware supports the 1-setting of the SNP field in the page-table entries.
6	RO	0b	Pass Through (PT) 0 = Hardware does not support pass through translation type in context entries. 1 = Hardware supports pass-through translation type in context entries.
5	RO	0b	Caching Hints (CH) 0 = Hardware does not support IOTLB caching hints (ALH and EH fields in context-entries are treated as reserved). 1 = Hardware supports IOTLB caching hints through the ALH and EH fields in context-entries.
4	RO	0b	Extended Interrupt Mode (EIM) 0 = Hardware supports only 8-bit APICIDs (Legacy Interrupt Mode) on Intel 64 and IA-32 architecture and 16-bit APIC-IDs. 1 = Hardware supports Extended Interrupt Mode (32-bit APIC-IDs) on Intel 64 platforms. This field is valid only when the IR field is reported as Set.
3	RO	0b	Interrupt Remapping Support (IR) 0 = Hardware does not support interrupt remapping. 1 = Hardware supports interrupt remapping. Implementations reporting this field as Set must also support Queued Invalidation (QI = 1b).



B/D/F/Type: Address Offset: Reset Value: Access:		0/0/0/VCOPREMAP 10–17h 000000000001000h RO	
Bit	Attr	Reset Value	Description
2	RO	0b	Device IOTLB Support (DI) 0 = Hardware does not support device- IOTLBs. 1 = Hardware supports Device-IOTLBs. Implementations reporting this field as Set must also support Queued Invalidation (QI = 1b).
1	RO	0b	Queued Invalidation Support (QI) 0 = Hardware does not support queued invalidations. 1 = Hardware supports queued invalidations.
0	RO	0b	Coherency (C) 0 = Indicates that hardware accesses to the root, context, and page table structures are non-coherent (non-snoop). 1 = Indicates that hardware accesses to the root, context, and page table structures are coherent (snoop). Hardware writes to the advanced fault log is required to be coherent

2.15.4 GCMD_REG—Global Command Register

This register controls DMA-remapping hardware. If multiple control fields in this register need to be modified, software must serialize through multiple writes to this register.

B/D/F/Type: Address Offset: Reset Value: Access:		0/0/0/VCOPREMAP 18–1Bh 00000000h W, WO, RO	
Bit	Attr	Reset Value	Description
31	W	0b	Translation Enable (TE) Software writes to this field to request hardware to enable/disable DMA-remapping hardware. 0 = Disable DMA-remapping hardware 1 = Enable DMA-remapping hardware Hardware reports the status of the translation enable operation through the TES field in the Global Status register. Before enabling (or re-enabling) DMA-remapping hardware through this field, software must: <ul style="list-style-type: none"> • Setup the DMA-remapping structures in memory • Flush the write buffers (through WBF field), if write buffer flushing is reported as required. • Set the root-entry table pointer in hardware (through SRTP field). • Perform global invalidation of the context-cache and global invalidation of IOTLB • If advanced fault logging supported, setup fault log pointer (through SFL field) and enable advanced fault logging (through EAFL field). Refer to the VTd specification for detailed software requirements. There may be active DMA requests in the platform when software updates this field. Hardware must enable or disable remapping logic only at deterministic transaction boundaries, so that any in-flight transaction is either subject to remapping or not at all. Hardware implementations supporting DMA draining must drain any in-flight translated DMA read/write requests queued within the root complex before completing the translation enable command and reflecting the status of the command through the TES field in the GSTS_REG. Value returned on read of this field is undefined.



B/D/F/Type:		O/O/O/VCOPREMAP	
Address Offset:		18–1Bh	
Reset Value:		00000000h	
Access:		W, WO, RO	
Bit	Attr	Reset Value	Description
30	WO	0b	<p>Set Root Table Pointer (SRTP)</p> <p>Software sets this field to set/update the root-entry table pointer used by hardware. The root-entry table pointer is specified through the Root-entry Table Address register. Hardware reports the status of the root table pointer set operation through the RTPS field in the Global Status register.</p> <p>The root table pointer set operation must be performed before enabling or re-enabling (after disabling) DMA-remapping hardware.</p> <p>After a root table pointer set operation, software must globally invalidate the context cache followed by global invalidate of IOTLB. This is required to ensure hardware uses only the remapping structures referenced by the new root table pointer, and not any stale cached entries.</p> <p>While DMA-remapping hardware is active, software may update the root table pointer through this field. However, to ensure valid in-flight DMA requests are deterministically remapped, software must ensure that the structures referenced by the new root table pointer are programmed to provide the same remapping results as the structures referenced by the previous root table pointer.</p> <p>Clearing this bit has no effect. The value returned on read of this field is undefined.</p>
29	W	0b	<p>Set Fault Log (SFL)</p> <p>This field is valid only for implementations supporting advanced fault logging. If advanced fault logging is not supported, writes to this field are ignored.</p> <p>Software sets this field to request hardware to set/update the fault-log pointer used by hardware. The fault-log pointer is specified through Advanced Fault Log register.</p> <p>Hardware reports the status of the fault log set operation through the FLS field in the Global Status register.</p> <p>The fault log pointer must be set before enabling advanced fault logging (through EAFL field). Once advanced fault logging is enabled, the fault log pointer may be updated through this field while DMA-remapping hardware is active.</p> <p>Clearing this bit has no effect. The value returned on read of this field is undefined.</p>
28	W	0b	<p>Enable Advanced Fault Logging (EAFL)</p> <p>This field is valid only for implementations supporting advanced fault logging. If advanced fault logging is not supported, writes to this field are ignored.</p> <p>Software writes to this field to request hardware to enable or disable advanced fault logging.</p> <p>0 = Disable advanced fault logging. In this case, translation faults are reported through the Fault Recording registers.</p> <p>1 = Enable use of memory-resident fault log.</p> <p>When enabled, translation faults are recorded in the memory-resident log. The fault log pointer must be set in hardware (through SFL field) before enabling advanced fault logging.</p> <p>Hardware reports the status of the advanced fault logging enable operation through the AFLS field in the Global Status register. Value returned on read of this field is undefined.</p>
27	WO	0b	<p>Write Buffer Flush (WBF)</p> <p>This bit is valid only for implementations requiring write buffer flushing. If write buffer flushing is not required, writes to this field are ignored.</p> <p>Software sets this field to request hardware to flush the root-complex internal write buffers. This is done to ensure any updates to the memory-resident DMA-remapping structures are not held in any internal write posting buffers. Refer to the VTd specification for details on write-buffer flushing requirements.</p> <p>Hardware reports the status of the write buffer flushing operation through the WBFS field in the Global Status register.</p> <p>Clearing this bit has no effect.</p> <p>Value returned on read of this field is undefined.</p>



B/D/F/Type: Address Offset: Reset Value: Access:		0/0/0/VCOPREMAP 18-1Bh 00000000h W, WO, RO	
Bit	Attr	Reset Value	Description
26	W	0b	Queued Invalidation Enable (QIE) This field is valid only for implementations supporting queued invalidations. Software writes to this field to enable or disable queued invalidations. 0 = Disable queued invalidations. 1 = Enable use of queued invalidations. Hardware reports the status of queued invalidation enable operation through QIES field in the Global Status register. Refer to the VTd specification for software requirements for enabling/disabling queued invalidations. The value returned on a read of this field is undefined.
25	W	0b	Interrupt Remapping Enable (IRE) This field is valid only for implementations supporting interrupt remapping. 0 = Disable interrupt-remapping hardware 1 = Enable interrupt-remapping hardware. Hardware reports the status of the interrupt remapping enable operation through the IRES field in the Global Status register. There may be active interrupt requests in the platform when software updates this field. Hardware must enable or disable interrupt-remapping logic only at deterministic transaction boundaries, so that any in-flight interrupts are either subject to remapping or not at all. Hardware implementations must drain any in-flight interrupts requests queued in the Root-Complex before completing the interrupt-remapping enable command and reflecting the status of the command through the IRES field in the Global Status register. The value returned on a read of this field is undefined.
24	W	0b	Set Interrupt Remap Table Pointer (SIRTP) This field is valid only for implementations supporting interrupt-remapping. Software sets this field to set/update the interrupt remapping table pointer used by hardware. The interrupt remapping table pointer is specified through the Interrupt Remapping Table Address register. Hardware reports the status of the interrupt remapping table pointer set operation through the IRTPS field in the Global Status register. The interrupt remap table pointer set operation must be performed before enabling or re-enabling (after disabling) interrupt-remapping hardware through the IRE field. After an interrupt remap table pointer set operation, software must globally invalidate the interrupt entry cache. This is required to ensure hardware uses only the interrupt-remapping entries referenced by the new interrupt remap table pointer, and not any stale cached entries. While interrupt remapping is active, software may update the interrupt remapping table pointer through this field. However, to ensure valid in-flight interrupt requests are deterministically remapped, software must ensure that the structures referenced by the new interrupt remap table pointer are programmed to provide the same remapping results as the structures referenced by the previous interrupt remap table pointer. Clearing this bit has no effect. The value returned on a read of this field is undefined.
23	W	0b	Compatibility Format Interrupt (CFI) This field is valid only for Intel 64 implementations supporting interrupt-remapping. Software writes to this field to enable or disable Compatibility Format interrupts on Intel 64 platforms. The value in this field is effective only when interrupt-remapping is enabled and Legacy Interrupt Mode is active. 0 = Block Compatibility format interrupts. 1 = Process Compatibility format interrupts as pass-through (bypass interrupt remapping). Hardware reports the status of updating this field through the CFIS field in the Global Status register. Refer to the VTd specification for details on Compatibility Format interrupt requests. The value returned on a read of this field is undefined. This field is not implemented.
22:0	RO	000000h	Reserved



2.15.5 GSTS_REG—Global Status Register

This register reports general DMA-remapping hardware status.

B/D/F/Type:		0/0/0/VCOPREMAP	
Address Offset:		1C–1Fh	
Reset Value:		00000000h	
Access:		RO	
Bit	Attr	Reset Value	Description
31	RO	0b	Translation Enable Status (TES) This field indicates the status of DMA-remapping hardware. 0 = DMA-remapping hardware is not enabled 1 = DMA-remapping hardware is enabled
30	RO	0b	Root Table Pointer Status (RTPS) This field indicates the status of the root-table pointer in hardware. This field is cleared by hardware when software sets the SRTP field in the Global Command register. This field is set by hardware when hardware completes the set root-table pointer operation using the value provided in the Root-Entry Table Address register.
29	RO	0b	Fault Log Status (FLS) This field is valid only for implementations supporting advanced fault logging. This field indicates the status of the fault-log pointer in hardware. This field is cleared by hardware when software sets the SFL field in the Global Command register. This field is set by hardware when hardware completes the set fault-log pointer operation using the value provided in the Advanced Fault Log register.
28	RO	0b	Advanced Fault Logging Status (AFLS) This field is valid only for implementations supporting advanced fault logging. This field indicates advanced fault logging status. 0 = Advanced Fault Logging is not enabled 1 = Advanced Fault Logging is enabled
27	RO	0b	Write Buffer Flush Status (WBFS) This bit is valid only for implementations requiring write buffer flushing. This field indicates the status of the write buffer flush operation. This field is set by hardware when software sets the WBF field in the Global Command register. This field is cleared by hardware when hardware completes the write buffer flushing operation.
26	RO	0b	Queued Invalidation Enable Status (QIES) This field indicates queued invalidation enable status. 0 = queued invalidation is not enabled 1 = queued invalidation is enabled
25	RO	0b	Interrupt Remapping Enable Status (IRES) This field indicates the status of Interrupt-remapping hardware. 0 = Interrupt-remapping hardware is not enabled 1 = Interrupt-remapping hardware is enabled
24	RO	0b	Interrupt Remapping Table Pointer Status (IRTPS) This field indicates the status of the interrupt remapping table pointer in hardware. This field is cleared by hardware when software sets the SIRTP field in the Global Command register. This field is Set by hardware when hardware completes the set interrupt remap table pointer operation using the value provided in the Interrupt Remapping Table Address register.



B/D/F/Type:		0/0/0/VCOPREMAP	
Address Offset:		1C–1Fh	
Reset Value:		00000000h	
Access:		RO	
Bit	Attr	Reset Value	Description
23	RO	0b	Compatibility Format Interrupt Status (CFIS) This field indicates the status of Compatibility format interrupts on Intel 64 implementations supporting interrupt-remapping. The value reported in this field is applicable only when interrupt-remapping is enabled and Legacy interrupt mode is active. 0 = Compatibility format interrupts are blocked. 1 = Compatibility format interrupts are processed as pass-through (bypassing interrupt remapping).
22:0	RO	000000h	Reserved

2.15.6 RTADDR_REG—Root-Entry Table Address Register

This register provides the base address of root-entry table.

B/D/F/Type:		0/0/0/VCOPREMAP	
Address Offset:		20–27h	
Reset Value:		0000000000000000h	
Access:		RW, RO	
Bit	Attr	Reset Value	Description
63:12	RW	00000000 00000h	Root table address (RTA) This register points to base of page aligned, 4 KB-sized root-entry table in system memory. Hardware may ignore and not implement bits 63:HAW, where HAW is the host address width. Software specifies the base address of the root-entry table through this register, and programs it in hardware through the SRTP field in the Global Command register. Reads of this register returns value that was last programmed to it.
11:0	RO	000h	Reserved



2.15.7 CCMD_REG—Context Command Register

Register to manage context cache. The act of writing the uppermost byte of the CCMD_REG with ICC field set causes the hardware to perform the context-cache invalidation.

B/D/F/Type: 0/0/0/VCOPREMAP Address Offset: 28–2Fh Reset Value: 0000000000000000h Access: W, RW, RO			
Bit	Attr	Reset Value	Description
63	RW	0b	<p>Invalidate Context-Cache (ICC)</p> <p>Software requests invalidation of context-cache by setting this field. Software must also set the requested invalidation granularity by programming the CIRG field.</p> <p>Software must read back and check the ICC field to be clear to confirm the invalidation is complete. Software must not update this register when this field is set.</p> <p>Hardware clears the ICC field to indicate the invalidation request is complete. Hardware also indicates the granularity at which the invalidation operation was performed through the CAIG field. Software must not submit another invalidation request through this register while the ICC field is set.</p> <p>Software must submit a context cache invalidation request through this field only when there are no invalidation requests pending at this DMA-remapping hardware unit. Refer to the VTd specification for software programming requirements.</p> <p>Since information from the context-cache may be used by hardware to tag IOTLB entries, software must perform domain-selective (or global) invalidation of IOTLB after the context cache invalidation has completed.</p> <p>Hardware implementations reporting write-buffer flushing requirement (RWBF=1 in Capability register) must implicitly perform a write buffer flushing before reporting invalidation complete to software through the ICC field.</p> <p>Refer to the VTd specification for write buffer flushing requirements.</p>
62:61	RW	0h	<p>Context Invalidation Request Granularity (CIRG)</p> <p>Software provides the requested invalidation granularity through this field when setting the ICC field. Following are the encodings for the CIRG field:</p> <ul style="list-style-type: none"> 00 = Reserved 01 = Global Invalidation request 10 = Domain-selective invalidation request. The target domain-id must be specified in the DID field. 11 = Device-selective invalidation request. The target source-id(s) must be specified through the SID and FM fields, and the domain-id (that was programmed in the context-entry for these device(s)) must be provided in the DID field. <p>Hardware implementations may process an invalidation request by performing invalidation at a coarser granularity than requested.</p> <p>Hardware indicates completion of the invalidation request by clearing the ICC field. At this time, hardware also indicates the granularity at which the actual invalidation was performed through the CAIG field.</p>



B/D/F/Type: Address Offset: Reset Value: Access:		0/0/0/VCOPREMAP 28–2Fh 0000000000000000h W, RW, RO	
Bit	Attr	Reset Value	Description
60:59	RO	0h	Context Actual Invalidation Granularity (CAIG) Hardware reports the granularity at which an invalidation request was processed through the CAIG field at the time of reporting invalidation completion (by clearing the ICC field). The following are the encodings for the CAIG field: 00 = Reserved 01 = Global Invalidation performed. This could be in response to a global, domain-selective or device-selective invalidation request. 10 = Domain-selective invalidation performed using the domain-id specified by software in the DID field. This could be in response to a domain-selective or device-selective invalidation request. 11 = Device-selective invalidation performed using the source-id and domain-id specified by software in the SID and FM fields. This can only be in response to a device-selective invalidation request.
58:34	RO	00..00b	Reserved
33:32	W	0h	Function Mask (FM) This field specifies which bits of the function number portion (least significant three bits) of the SID field to mask when performing device-selective invalidations. The following encodings are defined for this field: 00 = No bits in the SID field masked. 01 = Mask most significant bit of function number in the SID field. 10 =Mask two most significant bit of function number in the SID field. 11 =Mask all three bits of function number in the SID field. The device(s) specified through the FM and SID fields must correspond to the domain-id specified in the DID field. Value returned on read of this field is undefined.
31:16	W	0000h	Source ID (SID) This field indicates the source-id of the device whose corresponding context-entry needs to be selectively invalidated. This field along with the FM field must be programmed by software for device-selective invalidation requests. Value returned on read of this field is undefined.
15:0	RW	0000h	Domain-ID (DID) This field indicates the ID of the domain whose context-entries needs to be selectively invalidated. This field must be programmed by software for both domain-selective and device-selective invalidation requests. The Capability register reports the domain-id width supported by hardware. Software must ensure that the value written to this field is within this limit. Hardware may ignore and not implement bits 15:N where N is the supported domain-id width reported in the capability register.



2.15.8 FSTS_REG—Fault Status Register

This register indicates the primary fault logging status. The VTd specification describes hardware behavior for primary fault logging.

B/D/F/Type:		0/0/0/VCOPREMAP	
Address Offset:		34–37h	
Reset Value:		00000000h	
Access:		RO, RO-V-S, RW1C-S	
Bit	Attr	Reset Value	Description
31:16	RO	0000h	Reserved
15:8	RO-V-S	00h	<p>Fault Record Index (FRI)</p> <p>This field is valid only when the PPF field is set. The FRI field indicates the index (from base) of the fault recording register to which the first pending fault was recorded when the PPF field was set by hardware.</p> <p>Valid values for this field are from 0 to N, where N is the value reported through NFR field in the Capability register. The value read from this field is undefined when the PPF field is clear.</p>
7	RO	0b	Reserved
6	RW1C-S	0b	<p>Invalidation Time-out Error (ITE)</p> <p>Hardware detected a Device-IOTLB invalidation completion time-out. At this time, a fault event may be generated based on the programming of the Fault Event Control register. Hardware implementations not supporting Device-IOTLBs implement this bit as reserved.</p>
5	RW1C-S	0b	<p>Invalidation Completion Error (ICE)</p> <p>Hardware received an unexpected or invalid Device-IOTLB invalidation completion. This could be due to either an invalid ITag or invalid source-id in an invalidation completion response. At this time, a fault event may be generated based on the programming of the Fault Event Control register. Hardware implementations not supporting Device-IOTLBs implement this bit as reserved.</p>
4	RW1C-S	0b	<p>Invalidation Queue Error (IQE)</p> <p>Hardware detected an error associated with the invalidation queue. This could be due to either a hardware error while fetching a descriptor from the invalidation queue, or hardware detecting an erroneous or invalid descriptor in the invalidation queue. At this time, a fault event may be generated based on the programming of the Fault Event Control register. Hardware implementations not supporting queued invalidations implement this bit as reserved.</p>
3	RW1C-S	0b	<p>Advanced Pending Fault (APF)</p> <p>When this field is Clear, hardware sets this field when the first fault record (at index 0) is written to a fault log. At this time, a fault event is generated based on the programming of the Fault Event Control register. Software writing 1 to this field clears it. Hardware implementations not supporting advanced fault logging implement this bit as reserved.</p>
2	RW1C-S	0b	<p>Advanced Fault Overflow (AFO)</p> <p>Hardware sets this field to indicate advanced fault log overflow condition. At this time, a fault event is generated based on the programming of the Fault Event Control register. Software writing 1 to this field clears it. Hardware implementations not supporting advanced fault logging implement this bit as reserved.</p>
1	RO-V-S	0h	<p>Primary Pending Fault (PPF)</p> <p>This field indicates if there are one or more pending faults logged in the fault recording registers. Hardware computes this field as the logical OR of Fault (F) fields across all the fault recording registers of this DMA-remapping hardware unit.</p> <p>0 = No pending faults in any of the fault recording registers 1 = One or more fault recording registers has pending faults. The FRI field is updated by hardware whenever the PPF field is set by hardware. Also, depending on the programming of the Fault Event Control register, a fault event is generated when hardware sets this field.</p>
0	RW1C-S	0h	<p>Primary Fault Overflow (PFO)</p> <p>Hardware sets this field to indicate overflow of fault recording registers. Software writing 1 clears this field.</p>

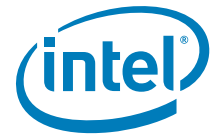

2.15.9 FECTL_REG—Fault Event Control Register

This register specifies the fault event interrupt message control bits. The VTd specification describes hardware handling of fault events.

B/D/F/Type:		0/0/0/VCOPREMAP	
Address Offset:		38–3Bh	
Reset Value:		8000000h	
Access:		RW, RO	
Bit	Attr	Reset Value	Description
31	RW	1b	<p>Interrupt Mask (IM)</p> <p>0 = No masking of interrupt. When a interrupt condition is detected, hardware issues an interrupt message (using the Fault Event Data & Fault Event Address register values).</p> <p>1 = This is the value on reset. Software may mask interrupt message generation by setting this field. Hardware is prohibited from sending the interrupt message when this field is set.</p>
30	RO	0b	<p>Interrupt Pending (IP)</p> <p>Hardware sets the IP field whenever it detects an interrupt condition. An interrupt condition is defined as:</p> <ul style="list-style-type: none"> When primary fault logging is active, an interrupt condition occurs when hardware records a fault through one of the Fault Recording registers and sets the PPF field in Fault Status register. If the PPF field was already set at the time of recording a fault, it is not treated as a new interrupt condition. When advanced fault logging is active, an interrupt condition occurs when hardware records a fault in the first fault record (at index 0) of the current fault log and sets the APF field in the Advanced Fault Log register. If the APF field was already set at the time of detecting/recording a fault, it is not treated as a new interrupt condition. <p>The IP field is kept set by hardware while the interrupt message is held pending. The interrupt message could be held pending due to interrupt mask (IM field) being set, or due to other transient hardware conditions.</p> <p>The IP field is cleared by hardware as soon as the interrupt message pending condition is serviced.</p> <p>This could be due to either:</p> <ul style="list-style-type: none"> Hardware issuing the interrupt message due to either change in the transient hardware condition that caused interrupt message to be held pending or due to software clearing the IM field. Software servicing the interrupting condition through one of the following ways: <ul style="list-style-type: none"> When primary fault logging is active, software clearing the Fault (F) field in all the Fault Recording registers with faults, causing the PPF field in Fault Status register to be evaluated as clear. When advanced fault logging is active, software clearing the APF field in Advanced Fault Log register.
29:0	RO	00..00b	Reserved



2.15.10 FEDATA_REG—Fault Event Data Register

This register specifies the interrupt message data.

B/D/F/Type:		0/0/0/VCOPREMAP	
Address Offset:		3C–3Fh	
Reset Value:		00000000h	
Access:		RO, RW	
Bit	Attr	Reset Value	Description
31:16	RO	0000h	Extended Interrupt Message Data (EIMD) This field is valid only for implementations supporting 32-bit MSI data fields. Hardware implementations supporting only 16-bit MSI data may treat this field as read-only (0).
15:0	RW	0000h	Interrupt message data (ID) Data value in the fault-event interrupt message.

2.15.11 FEADDR_REG—Fault Event Address Register

This register specifies the interrupt message address.

B/D/F/Type:		0/0/0/VCOPREMAP	
Address Offset:		40–43h	
Reset Value:		00000000h	
Access:		RW, RO	
Bit	Attr	Reset Value	Description
31:2	RW	00000000h	Message Address (MA) When fault events are enabled, the contents of this register specify the DWORD aligned address (bits 31:2) for the MSI memory write transaction.
1:0	RO	0h	Reserved

2.15.12 FEUADDR_REG—Fault Event Upper Address Register

This register specifies the interrupt message address. For platforms supporting only interrupt messages in the 32-bit address range, this register is treated as read-only (0).

B/D/F/Type:		0/0/0/VCOPREMAP	
Address Offset:		44–47h	
Reset Value:		00000000h	
Access:		RO	
Bit	Attr	Reset Value	Description
31:0	RO	00000000h	Message upper address (MUA) This register need to be implemented only if hardware supports 64-bit message address. If implemented, the contents of this register specify the upper 32-bits of a 64-bit MSI write transaction. If hardware does not support 64-bit messages, the register is treated as read-only (0).



2.15.13 AFLOG_REG—Advanced Fault Log Register

This register specifies the base address of memory-resident fault-log region.

This register is treated as read-only (0) for implementations not supporting advanced translation fault logging (AFL field reported as 0 in the Capability register).

This register is sticky and can be cleared only through a powergood reset or using software clearing the RW1C fields by writing a 1.

B/D/F/Type:		0/0/0/VCOPREMAP	
Address Offset:		58–5Fh	
Reset Value:		0000000000000000h	
Access:		RO	
Bit	Attr	Reset Value	Description
63:12	RO	00000000 00000h	Fault Log Address (FLA) This field specifies the base of size-aligned fault-log region in system memory. Hardware may ignore and not implement bits 63:HAW, where HAW is the host address width. Software specifies the base address and size of the fault log region through this register, and programs it in hardware through the SFL field in the Global Command register. When implemented, reads of this field returns value that was last programmed to it.
11:9	RO	0h	Fault Log Size (FLS) This field specifies the size of the fault log region pointed by the FLA field. The size of the fault log region is 2X * 4KB, where X is the value programmed in this register. When implemented, reads of this field returns value that was last programmed to it.
8:2	RO	00h	Reserved
1	RO	0h	Advanced Pending Fault (APF) When this field is clear, hardware sets this field When the first fault record (at index 0) is written to a fault log. At this time, a fault event is generated based on the programming of the Fault Event Control register. Software writing 1 to this field clears it.
0	RO	0h	Advanced Fault Overflow (AFO) Hardware sets this field to indicate advanced fault log overflow condition. Software writing 1 to this field clears it.

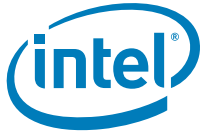

2.15.14 PMEM_REG—Protected Memory Enable Register

This register enables the DMA protected memory regions setup through the PLMBASE, PLMLIMIT, PHMBASE, PHMLIMIT registers. When LT.CMD.LOCK.PMRC command is invoked, this register is locked (treated RO). When LT.CMD.UNLOCK.PMRC command is invoked, this register is unlocked (treated RW). This register is always treated as RO (0) for implementations not supporting protected memory regions (PLMR and PHMR fields reported as 0 in the Capability register).

B/D/F/Type:		0/0/0/VCOPREMAP	
Address Offset:		64–67h	
Reset Value:		00000000h	
Access:		RW, RO	
Bit	Attr	Reset Value	Description
31	RW	0h	<p>Enable Protected Memory (EPM)</p> <p>This field controls DMA accesses to the protected low-memory and protected high-memory regions.</p> <p>0 = DMA accesses to protected memory regions are handled as follows:</p> <ul style="list-style-type: none"> — If DMA-remapping hardware is not enabled, DMA requests (including those to protected regions) are not blocked. — If DMA-remapping hardware is enabled, DMA requests are translated per the programming of the DMA-remapping structures. Software may program the DMA-remapping structures to allow or block DMA to the protected memory regions. <p>1 = DMA accesses to protected memory regions are handled as follows:</p> <ul style="list-style-type: none"> — If DMA-remapping hardware is not enabled, DMA to protected memory regions are blocked. These DMA requests are not recorded or reported as DMA-remapping faults. — If DMA-remapping hardware is enabled, hardware may or may not block DMA to the protected memory region(s). Software must not depend on hardware protection of the protected memory regions, and must ensure the DMA-remapping structures are properly programmed to not allow DMA to the protected memory regions. Hardware reports the status of the protected memory enable/disable operation through the PRS field in this register. Hardware implementations supporting DMA draining must drain any in-flight translated DMA requests queued within the root complex before indicating the protected memory region as enabled through the PRS field.
30:1	RO	00000000h	Reserved
0	RO	0h	<p>Protected Region Status (PRS)</p> <p>This field indicates the status of protected memory region.</p> <p>0 = Protected memory region(s) not enabled. 1 = Protected memory region(s) enabled.</p>



2.15.15 PLMBASE_REG—Protected Low-Memory Base Register

This register is used to setup the base address of DMA protected low-memory region. The register must be setup before enabling protected memory through PMEN_REG, and must not be updated when protected memory regions are enabled. When LT.CMD.LOCK.PMRC command is invoked, this register is locked (treated RO). When LT.CMD.UNLOCK.PMRC command is invoked, this register is unlocked (treated RW). This register is always treated as RO for implementations not supporting protected low memory region (PLMR field reported as 0 in the Capability register). The alignment of the protected low memory region base depends on the number of reserved bits (N) of this register. Software may determine the value of N by writing all 1s to this register, and finding most significant zero bit position with 0 in the value read back from the register. Bits N:0 of this register is decoded by hardware as all 0s.

B/D/F/Type: 0/0/0/VCOPREMAP Address Offset: 68–6Bh Reset Value: 00000000h Access: RW, RO			
Bit	Attr	Reset Value	Description
31:21	RW	000h	Protected Low-Memory Base (PLMB) This register specifies the base of size aligned, protected low-memory region in system memory. The protected low-memory region has a minimum size of 2 MB and must be size aligned.
20:0	RO	000000h	Reserved



2.15.16 PLMLIMIT_REG—Protected Low-Memory Limit Register

Register to setup the limit address of DMA protected low-memory region. This register must be setup before enabling protected memory through PMEN_REG, and must not be updated when protected memory regions are enabled. When LT.CMD.LOCK.PMRC command is invoked, this register is locked (treated RO). When LT.CMD.UNLOCK.PMRC command is invoked, this register is unlocked (treated RW). This register is always treated as RO for implementations not supporting protected low memory region (PLMR field reported as 0 in the Capability register). The alignment of the protected low memory region limit depends on the number of reserved bits (N) of this register. Software may determine the value of N by writing all 1s to this register, and finding most significant zero bit position with 0 in the value read back from the register. Bits N:0 of the limit register is decoded by hardware as all 1s. The Protected low-memory base & limit registers functions as follows.

- Programming the protected low-memory base and limit registers with the same value in bits 31:(N+1) specifies a protected low-memory region of size 2(N+1) bytes.
- Programming the protected low-memory limit register with a value less than the protected low-memory base register disables the protected low-memory region.

B/D/F/Type:		0/0/0/VCOPREMAP	
Address Offset:		6C–6Fh	
Reset Value:		0000000h	
Access:		RW, RO	
Bit	Attr	Reset Value	Description
31:21	RW	000h	Protected Low-Memory Limit (PLML) This register specifies the last host physical address of the DMA protected low-memory region in system memory.
20:0	RO	000000h	Reserved

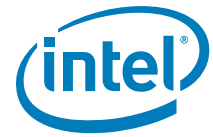

2.15.17 PHMBASE_REG—Protected High-Memory Base Register

This register is used to setup the base address of DMA protected high-memory region. This register must be setup before enabling protected memory through PMEN_REG, and must not be updated when protected memory regions are enabled. When LT.CMD.LOCK.PMRC command is invoked, this register is locked (treated RO). When LT.CMD.UNLOCK.PMRC command is invoked, this register is unlocked (treated RW). This register is always treated as RO for implementations not supporting protected high memory region (PHMR field reported as 0 in the Capability register). The alignment of the protected high memory region base depends on the number of reserved bits (N) of this register. Software may determine the value of N by writing all 1s to this register, and finding most significant zero bit position below host address width (HAW) in the value read back from the register. Bits N:0 of the limit register is decoded by hardware as all 0s.

B/D/F/Type:		0/0/0/VCOPREMAP	
Address Offset:		70–77h	
Reset Value:		0000000000000000h	
Access:		RW, RO	
Bit	Attr	Reset Value	Description
63:21	RW	00000000 000h	Protected High-Memory Base (PHMB) This register specifies the base of size aligned, protected memory region in system memory. Hardware may not utilize bits 63:HAW, where HAW is the host address width. The protected high-memory region has a minimum size of 2 MB and must be size aligned.
20:0	RO	000000h	Reserved



2.15.18 PHMLIMIT_REG—Protected High-Memory Limit Register

Register to setup the limit address of DMA protected high-memory region. This register must be setup before enabling protected memory through PMEN_REG, and must not be updated when protected memory regions are enabled. When LT.CMD.LOCK.PMRC command is invoked, this register is locked (treated RO). When LT.CMD.UNLOCK.PMRC command is invoked, this register is unlocked (treated RW). This register is always treated as RO for implementations not supporting protected high memory region (PHMR field reported as 0 in the Capability register). The alignment of the protected high memory region limit depends on the number of reserved bits (N) of this register. Software may determine the value of N by writing all 1's to this register, and finding most significant zero bit position below host address width (HAW) in the value read back from the register. Bits N:0 of the limit register is decoded by hardware as all 1s. The protected high-memory base and limit registers functions as follows:

- Programming the protected low-memory base and limit registers with the same value in bits HAW: (N+1) specifies a protected low-memory region of size 2(N+1) bytes.
- Programming the protected high-memory limit register with a value less than the protected high-memory base register disables the protected high-memory region.

B/D/F/Type:		0/0/0/VCOPREMAP	
Address Offset:		78–7Fh	
Reset Value:		0000000000000000h	
Access:		RW, RO	
Bit	Attr	Reset Value	Description
63:21	RW	00000000 000h	Protected High-Memory Limit (PHML) This register specifies the last host physical address of the DMA protected high-memory region in system memory. Hardware may not use bits 63:HAW, where HAW is the host address width.
20:0	RO	000000h	Reserved

2.15.19 IQH_REG—Invalidation Queue Head Register

This register indicates the invalidation queue head. This register is treated as reserved by implementations reporting Queued Invalidation (QI) as not supported in the Extended Capability register.

B/D/F/Type:		0/0/0/VCOPREMAP	
Address Offset:		80–87h	
Reset Value:		0000000000000000h	
Access:		RO	
Bit	Attr	Reset Value	Description
63:19	RO	00000000 0000h	Reserved
18:4	RO	0000h	Queue Head (QH) This field specifies the offset (128-bit aligned) to the invalidation queue for the command that will be fetched next by hardware. Hardware resets this field to 0 whenever the queued invalidation is disabled (QIES field Clear in the Global Status register).
3:0	RO	0h	Reserved



2.15.20 IQT_REG—Invalidation Queue Tail Register

Register indicating the invalidation tail head. This register is treated as reserved by implementations reporting Queued Invalidation (QI) as not supported in the Extended Capability register.

B/D/F/Type:		0/0/0/VCOPREMAP	
Address Offset:		88–8Fh	
Reset Value:		0000000000000000h	
Access:		RO	
Bit	Attr	Reset Value	Description
63:19	RO	00000000 0000h	Reserved
18:4	RO	0000h	Queue Tail (QT) This field specifies the offset (128-bit aligned) to the invalidation queue for the command that will be written next by software.
3:0	RO	0h	Reserved

2.15.21 IQA_REG—Invalidation Queue Address Register

Register to configure the base address and size of the invalidation queue. This register is treated as reserved by implementations reporting Queued Invalidation (QI) as not supported in the Extended Capability register. When supported, writing to this register causes the Invalidation Queue Head and Invalidation Queue Tail registers to be reset to 0h.

B/D/F/Type:		0/0/0/VCOPREMAP	
Address Offset:		90–97h	
Reset Value:		0000000000000000h	
Access:		RW, RO	
Bit	Attr	Reset Value	Description
63:12	RW	00000000 0000h	Invalidation Queue Base Address (IQA) This field points to the base of 4 KB aligned invalidation request queue. Hardware ignores and not implement bits 63:HAW, where HAW is the host address width. Reads of this field return the value that was last programmed to it.
11:3	RO	000h	Reserved
2:0	RW	0h	Queue Size (QS) This field specifies the size of the invalidation request queue. A value of X in this field indicates an invalidation request queue of (X+1) 4 KB pages. The number of entries in the invalidation queue is 2(X + 8).



2.15.22 ICS_REG—Invalidation Completion Status Register

This register reports the completion status of invalidation wait descriptor with Interrupt Flag (IF) Set. This register is treated as reserved by implementations reporting Queued Invalidation (QI) as not supported in the Extended Capability register.

B/D/F/Type:		0/0/0/VCOPREMAP	
Address Offset:		9C–9Fh	
Reset Value:		00000000h	
Access:		RO, RW1C-S	
Bit	Attr	Reset Value	Description
31:1	RO	00000000h	Reserved
0	RW1C-S	0b	Invalidation Wait Descriptor Complete (IWC) This bit indicates completion of Invalidation Wait Descriptor with Interrupt Flag (IF) field Set. Hardware implementations not supporting queued invalidations implement this field as reserved.

2.15.23 IECTL_REG—Invalidation Event Control Register

This register specifies the invalidation event interrupt control bits. This register is treated as reserved by implementations reporting Queued Invalidation (QI) as not supported in the Extended Capability register.

B/D/F/Type:		0/0/0/VCOPREMAP	
Address Offset:		A0–A3h	
Reset Value:		00000000h	
Access:		RW, RO	
Bit	Attr	Reset Value	Description
31	RW	0b	Interrupt Mask (IM) 0 = No masking of interrupt. When a invalidation event condition is detected, hardware issues an interrupt message (using the Invalidation Event Data & Invalidation Event Address register values). 1 = This is the value on reset. Software may mask interrupt message generation by setting this field. Hardware is prohibited from sending the interrupt message when this field is Set.
30	RO	0b	Interrupt Pending (IP) Hardware sets the IP field whenever it detects an interrupt condition. Interrupt condition is defined as: <ul style="list-style-type: none"> An Invalidation Wait Descriptor with Interrupt Flag (IF) field Set completed, setting the IWC field in the Invalidation Completion Status register. If the IWC field in the Invalidation Completion Status register was already set at the time of setting this field, it is not treated as a new interrupt condition. The IP field is kept set by hardware while the interrupt message is held pending. The interrupt message could be held pending due to interrupt mask (IM field) being set, or due to other transient hardware conditions. The IP field is cleared by hardware as soon as the interrupt message pending condition is serviced. This could be due to either: <ul style="list-style-type: none"> Hardware issuing the interrupt message due to either change in the transient hardware condition that caused interrupt message to be held pending or due to software clearing the IM field. Software servicing the IWC field in the Invalidation Completion Status register.
29:0	RO	00000000h	Reserved

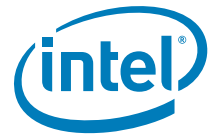

2.15.24 IEDATA_REG—Invalidation Event Data Register

Register specifying the Invalidation Event interrupt message data. This register is treated as reserved by implementations reporting Queued Invalidation (QI) as not supported in the Extended Capability register.

B/D/F/Type:		0/0/0/VCOPREMAP	
Address Offset:		A4–A7h	
Reset Value:		00000000h	
Access:		RW	
Bit	Attr	Reset Value	Description
31:16	RW	0000h	Extended Interrupt Message Data (EIMD) This field is valid only for implementations supporting 32-bit interrupt data fields. Hardware implementations supporting only 16-bit interrupt data treat this field as reserved.
15:0	RW	0000h	Interrupt Message Data (IMD) Data value in the interrupt request. Software requirements for programming this register are described in the VTd specification.

2.15.25 IEADDR_REG—Invalidation Event Address Register

This register specifies the Invalidation Event Interrupt message address. This register is treated as reserved by implementations reporting Queued Invalidation (QI) as not supported in the Extended Capability register.

B/D/F/Type:		0/0/0/VCOPREMAP	
Address Offset:		A8–ABh	
Reset Value:		00000000h	
Access:		RW, RO	
Bit	Attr	Reset Value	Description
31:2	RW	00000000h	Message address (MA) When fault events are enabled, the contents of this register specify the DWORD-aligned address (bits 31:2) for the interrupt request. Software requirements for programming this register are described in the VTd specification.
1:0	RO	00b	Reserved



2.15.26 IEUADDR_REG—Invalidation Event Upper Address Register

This register specifies the Invalidation Event interrupt message upper address. This register is treated as reserved by implementations reporting both Queued Invalidation (QI) and Extended Interrupt Mode (EIM) as not supported in the Extended Capability register.

B/D/F/Type: 0/0/0/VCOPREMAP Address Offset: AC–AFh Reset Value: 00000000h Access: RW			
Bit	Attr	Reset Value	Description
31:0	RW	00000000h	Message Upper Address (MUA) Hardware implementations supporting Queued Invalidation and Extended Interrupt Mode are required to implement this register. Software requirements for programming this register are described in the VTd specification. Hardware implementations not supporting Queued Invalidation and Extended Interrupt Mode may treat this field as reserved.

2.15.27 IRTA_REG—Interrupt Remapping Table Address Register

Register providing the base address of Interrupt remapping table. This register is treated as reserved by implementations reporting Interrupt Remapping (IR) as not supported in the Extended Capability register.

B/D/F/Type: 0/0/0/VCOPREMAP Address Offset: B8–BFh Reset Value: 0000000000000000h Access: RW, RO			
Bit	Attr	Reset Value	Description
63:12	RW	0000000000000h	Interrupt Remapping Table Address (IRTA) This field points to the base interrupt remapping table. Hardware ignores and not 63:HAW, where HAW is the width. Reads of this field returns last programmed to it.

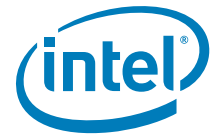

2.15.28 IVA_REG—Invalidate Address Register

This register provides the DMA address whose corresponding IOTLB entry needs to be invalidated through the corresponding IOTLB Invalidate register. This register is a write-only register. Value returned on reads of this register is undefined. There is an IVA_REG for each IOTLB Invalidation unit supported by hardware.

B/D/F/Type:		0/0/0/VCOPREMAP																															
Address Offset:		100–107h																															
Reset Value:		0000000000000000h																															
Access:		W, RO																															
Bit	Attr	Reset Value	Description																														
63:12	W	00000000 00000h	Address (Addr) Software provides the DMA address that needs to be page-selectively invalidated. To request a page-selective invalidation request to hardware, software must first write the appropriate fields in this register, and then issue appropriate page-selective invalidate command through the IOTLB_REG. Hardware ignores bits 63:N, where N is the maximum guest address width (MGAW) supported. Value returned on read of this field is undefined.																														
11:7	RO	00h	Reserved																														
6	W	0h	Invalidation Hint (IH) The field provides hint to hardware to preserve or flush the non-leaf (page-directory) entries that may be cached in hardware. 0 = Software may have modified both leaf and non-leaf page-table entries corresponding to mappings specified in the ADDR and AM fields. On a page selective invalidation request, hardware must flush both the cached leaf and non-leaf page-table Value returned on a read of this field is undefined. Entries corresponding to mappings specified by ADDR and AM fields. 1 = Software has not modified any non-leaf page-table entries corresponding to mappings specified in the ADDR and AM fields. On a page-selective invalidation request, hardware may preserve the cached non-leaf page-table entries corresponding to mappings specified by ADDR and AM fields.																														
5:0	W	00h	Address Mask (AM) The value in this field specifies the number of low order bits of the ADDR field that must be masked for the invalidation operation. The Mask field enables software to request invalidation of contiguous mappings for size-aligned regions. For example: Mask Value ADDR bits masked Pages invalidated <table border="1"> <thead> <tr> <th>Mask Value</th> <th>Addr bits masked</th> <th>Pg inval</th> </tr> </thead> <tbody> <tr><td>0</td><td>Nil</td><td>1</td></tr> <tr><td>1</td><td>12</td><td>2</td></tr> <tr><td>2</td><td>13:12</td><td>4</td></tr> <tr><td>3</td><td>14:12</td><td>8</td></tr> <tr><td>4</td><td>15:12</td><td>16</td></tr> <tr><td>5</td><td>16:12</td><td>32</td></tr> <tr><td>6</td><td>17:12</td><td>64</td></tr> <tr><td>7</td><td>18:12</td><td>128</td></tr> <tr><td>8</td><td>19:12</td><td>256</td></tr> </tbody> </table> Hardware implementations report the maximum supported mask value through the Capability register. Value returned on read of this field is undefined.	Mask Value	Addr bits masked	Pg inval	0	Nil	1	1	12	2	2	13:12	4	3	14:12	8	4	15:12	16	5	16:12	32	6	17:12	64	7	18:12	128	8	19:12	256
Mask Value	Addr bits masked	Pg inval																															
0	Nil	1																															
1	12	2																															
2	13:12	4																															
3	14:12	8																															
4	15:12	16																															
5	16:12	32																															
6	17:12	64																															
7	18:12	128																															
8	19:12	256																															



2.15.29 IOTLB_REG—IOTLB Invalidate Register

Register to control page-table entry caching. The act of writing the upper byte of the IOTLB_REG with IVT field set causes the hardware to perform the IOTLB invalidation.

There is an IOTLB_REG for each IOTLB Invalidation unit supported by hardware.

B/D/F/Type:		0/0/0/VCOPREMAP	
Address Offset:		108–10Fh	
Reset Value:		0000000000000000h	
Access:		RW, RO	
Bit	Attr	Reset Value	Description
63	RW	0b	<p>Invalidate IOTLB (IVT)</p> <p>Software requests IOTLB invalidation by setting this field. Software must also set the requested invalidation granularity by programming the IIRG field.</p> <p>Hardware clears the IVT field to indicate the invalidation request is complete. Hardware also indicates the granularity at which the invalidation operation was performed through the IAIG field. Software must not submit another invalidation request through this register while the IVT field is set, nor update the associated Invalidate Address register.</p> <p>Software must not submit IOTLB invalidation requests through any of the IOTLB invalidation units when there is a context-cache invalidation request pending at this DMA-remapping hardware unit.</p> <p>When more than one IOTLB invalidation units are supported by a DMA-remapping hardware unit, software may submit IOTLB invalidation request through any of the currently free units while there are pending requests on other units.</p> <p>Refer to the VTd specification for software programming requirements.</p> <p>Hardware implementations reporting write-buffer flushing requirement (RWBF=1 in Capability register) must implicitly perform a write buffer flushing before reporting invalidation complete to software through the IVT field.</p> <p>Refer to the VTd specification for write buffer flushing requirements.</p>
62:60	RW	0h	<p>IOTLB Invalidation Request Granularity (IIRG)</p> <p>When requesting hardware to invalidate the IOTLB (by setting the IVT field), software writes the requested invalidation granularity through this IIRG field. Following are the encodings for the IIRG field.</p> <p>000 = Reserved.</p> <p>001 = Global invalidation request.</p> <p>010 = Domain-selective invalidation request. The target domain-id must be specified in the DID field.</p> <p>011 = Domain-page-selective invalidation request. The target address, mask and invalidation hint must be specified in the Invalidate Address register, and the domain-id must be provided in the DID field.</p> <p>100–111 = Reserved.</p> <p>Hardware implementations may process an invalidation request by performing invalidation at a coarser granularity than requested. Hardware indicates completion of the invalidation request by clearing the IVT field. At this time, the granularity at which actual invalidation was performed is reported through the IAIG field.</p>



B/D/F/Type:		0/0/0/VCOPREMAP	
Address Offset:		108–10Fh	
Reset Value:		0000000000000000h	
Access:		RW, RO	
Bit	Attr	Reset Value	Description
59:57	RO	0h	<p>IOTLB Actual Invalidation Granularity (IAIG)</p> <p>Hardware reports the granularity at which an invalidation request was processed through this field at the time of reporting invalidation completion (by clearing the IVT field).</p> <p>The following are the encodings for the IAIG field.</p> <p>000 = Reserved. This indicates hardware detected an incorrect invalidation request and ignored the request. Examples of incorrect invalidation requests include detecting an unsupported address mask value in Invalidate Address register for page-selective invalidation requests.</p> <p>001 = Global Invalidation performed. This could be in response to a global, domain-selective, domain-page-selective, or device-page-selective invalidation request.</p> <p>010 = Domain-selective invalidation performed using the domain-id specified by software in the DID field. This could be in response to a domain-selective, domain-page-selective, or device-page-selective invalidation request.</p> <p>011 = Domain-page-selective invalidation performed using the address, mask and hint specified by software in the Invalidate Address register and domain-id specified in DID field. This can be in response to a domain-page-selective or device-page-selective invalidation request.</p> <p>100– 111 = Reserved.</p>
56:50	RO	00h	Reserved
49	RW	000000h	<p>Drain Reads (DR)</p> <p>This field is ignored by hardware if the DRD field is reported as clear in the Capability register. When the DRD field is reported as set in the Capability register, the following encodings are supported for this field:</p> <p>0 = Hardware may complete the IOTLB invalidation without draining any translated DMA reads that are queued in the root-complex and yet to be processed.</p> <p>1 = Hardware must drain all/relevant translated DMA reads that are queued in the root-complex before indicating IOTLB invalidation completion to software. A DMA read request to system memory is defined as drained when root-complex has finished fetching all of its read response data from memory.</p>
48	RW	00h	<p>Drain Writes (DW)</p> <p>This field is ignored by hardware if the DWD field is reported as clear in the Capability register. When DWD field is reported as set in the Capability register, the following encodings are supported for this field:</p> <p>0 = Hardware may complete the IOTLB invalidation without draining any translated DMA writes that are queued in the root-complex for processing.</p> <p>1 = Hardware must drain all/relevant translated DMA writes that are queued in the root-complex before indicating IOTLB invalidation completion to software. A DMA write request to system memory is defined as drained when the effects of the write is visible to the processor accesses to all addresses targeted by the DMA write.</p>
47:32	RW	0000h	<p>Domain-ID (DID)</p> <p>This field indicates the ID of the domain whose IOTLB entries needs to be selectively invalidated. This field must be programmed by software for domain-selective, domainpage-selective, and device-page-selective invalidation requests. The Capability register reports the domain-id width supported by hardware. Software must ensure that the value written to this field is within this limit. Hardware may ignore and not implement bits 47: (32+N) where N is the supported domain-id width reported in the capability register.</p>
31:0	RO	00000000h	Reserved



2.15.30 FRCD_REG—Fault Recording Registers

This registers records DMA-remapping fault information when primary fault logging is active. Hardware reports the number and location of fault recording registers through the Capability register.

This register is relevant only for primary fault logging.

These registers are sticky and can be cleared only through powergood reset or using software clearing the RW1C fields by writing a 1.

B/D/F/Type:		0/0/0/VCOPREMAP	
Address Offset:		200–20Fh	
Reset Value:		00000000000000000000000000000000h	
Access:		RW1C-S, RO-V-S, RO	
Bit	Attr	Reset Value	Description
127	RW1C-S	0b	Fault (F) Hardware sets this field to indicate a fault is logged in this Fault Recording register. The F field is set by hardware after the details of the fault is recorded in the PADDR, SID, FR, and T fields. When this field is set, hardware may collapse additional faults from the same requestor (SID). Software writes the value read from this field to clear it. Refer to the VTd specification for hardware details of primary fault logging.
126	RO-V-S	0b	Type (T) Type of the faulted DMA request 0 = DMA write 1 = DMA read request This field is relevant only when the F field is set.
125:124	RO-V-S	00b	Address Type (AT) This field captures the AT field from the faulted DMA request. Hardware implementations not supporting Device- IOTLBs (DI field Clear in Extended Capability register) treat this field as reserved. When supported, this field is valid only when the F field is Set, and when the fault reason (FR) indicates one of the DMA-remapping fault conditions.
123:104	RO	00000h	Reserved
103:96	RO-V-S	00h	Fault Reason (FR) This field contains the reason for the fault. The VT specification 1.2 Appendix enumerates the various translation fault reason encodings. This field is relevant only when the F field is set.
95:80	RO	0000h	Reserved
79:64	RO-V-S	0000h	Source Identifier (SID) This field contains the Requester-id of the faulted DMA request. This field is relevant only when the F field is set.
63:12	RO-V-S	00000000 00000h	Page Address (PADDR) This field contains the address (page-granular) in the faulted DMA request. Hardware may treat bits 63:N as reserved (0), where N is the maximum guest address width (MGAW) supported. This field is relevant only when the F field is set.
11:0	RO	000h	Reserved



2.15.31 VTCMPLRESR—VT Completion Resource Dedication

This register provides a programmable interface to dedicate the DMI Completion Tracking Queue resources to DMI VC0 Read, DMI VC0 Write, DMI VC1 and DMI VCp VT fetch and PEG Completion Tracking Queue resources to PEG VC0 read and PEG VC0 write VT fetch.

B/D/F/Type:		0/0/0/VCOPREMAP	
Address Offset:		F00–F03h	
Reset Value:		00060000h	
Access:		RW-L, RO	
Bit	Attr	Reset Value	Description
31:20	RW-L	000h	Reserved
19:16	RO	6h	DMI VT Completion Tracking Queue Resource Available (DMIVTCTRA) Number of entries available in DMI VT Completion Tracking Queue. 1-based. The values programmed in the fields below must not be greater than the value advertised in this field.
15:12	RW-L	0h	DMI VC1 VT Completion Tracking Queue Resource Threshold (DMIVC1CTQRT) This field provides a 1-based minimum threshold value used to throttle DMI VC1 VT fetch. When the number of free DMI VT Completion Tracking Queue entries equals or falls below the value programmed in this field, DMI VC1 VT fetch is throttled until the number of free DMI Completion Tracking Queue entries rise above this threshold. For example: 0000 = Throttle DMI VC1 VT Fetch when there is no entry left. 0001 = Throttle DMI VC1 VT Fetch when there is 1 or less entry left. 0010 = Throttle DMI VC1 VT Fetch when there is 2 or less entry left. 0011 = Throttle DMI VC1 VT Fetch when there is 3 or less entry left. 0100 = Throttle DMI VC1 VT Fetch when there is 4 or less entry left. 0101–1111 = Reserved.
11:8	RW-L	0h	DMI VCp VT Completion Tracking Queue Resource Threshold (DMIVCPCTQRT) This field provides a 1-based minimum threshold value used to throttle DMI VCp VT fetch. When the number of free DMI VT Completion Tracking Queue entries equals or falls below the value programmed in this field, DMI VCp VT fetch is throttled until the number of free DMI Completion Tracking Queue entries rise above this threshold. For example: 0000 = Throttle DMI VCp VT Fetch when there is no entry left. 0001 = Throttle DMI VCp VT Fetch when there is 1 or less entry left. 0010 = Throttle DMI VCp VT Fetch when there is 2 or less entry left. 0011 = Throttle DMI VCp VT Fetch when there is 3 or less entry left. 0100 = Throttle DMI VCp VT Fetch when there is 4 or less entry left. 0101–1111 = Reserved.
7:4	RW-L	0h	DMI VC0 Write VT Completion Tracking Queue Resource Threshold (DMIVC0WRCTQRT) This field provides a 1-based minimum threshold value used to throttle DMI VC0 Write VT fetch. When the number of free DMI VT Completion Tracking Queue entries equals or falls below the value programmed in this field, DMI VC0 Write VT fetch is throttled until the number of free DMI Completion Tracking Queue entries rise above this threshold. For example: 0000 = Throttle DMI VC0 Write VT Fetch when there is no entry left. 0001 = Throttle DMI VC0 Write VT Fetch when there is 1 or less entry left. 0010 = Throttle DMI VC0 Write VT Fetch when there is 2 or less entry left. 0011 = Throttle DMI VC0 Write VT Fetch when there is 3 or less entry left. 0100 = Throttle DMI VC0 Write VT Fetch when there is 4 or less entry left. 0101–1111 = Reserved.



B/D/F/Type:		0/0/0/VCOPREMAP	
Address Offset:		F00–F03h	
Reset Value:		00060000h	
Access:		RW-L, RO	
Bit	Attr	Reset Value	Description
3:0	RW-L	0h	<p>DMI VCO Read VT Completion Tracking Queue Resource Threshold (DMIVCORDCTQRT)</p> <p>This field provides a 1-based minimum threshold value used to throttle DMI VCO Read VT fetch. When the number of free DMI VT Completion Tracking Queue entries equals or falls below the value programmed in this field, DMI VCO Read VT fetch is throttled until the number of free DMI Completion Tracking Queue entries rise above this threshold. For example:</p> <p>0000 = Throttle DMI VCO Read VT Fetch when there is no entry left. 0001 = Throttle DMI VCO Read VT Fetch when there is 1 or less entry left. 0010 = Throttle DMI VCO Read VT Fetch when there is 2 or less entry left. 0011 = Throttle DMI VCO Read VT Fetch when there is 3 or less entry left. 0100 = Throttle DMI VCO Read VT Fetch when there is 4 or less entry left. 0101–1111 = Reserved.</p>

2.15.32 VTFTCHARBCTL—VCO/VCp VTd Fetch Arbiter Control

This register controls the relative grant count given to each of the DMI VCO, DMI VC1, and PEG VCO VT fetch requests.

B/D/F/Type:		0/0/0/VCOPREMAP	
Address Offset:		F04–F07h	
Reset Value:		0000_FFFFh	
Access:		RW-L	
Bit	Attr	Reset Value	Description
31:16	RW-L	0000h	Reserved
15:12	RW-L	Fh	<p>PEG1 VCO VT Fetch Grant Count (PEG1VCOGNTCNT)</p> <p>The arbiter will continue to grant PEG1 VCO VT fetch as long as the grant count value in this field is greater than zero.</p>
11:8	RW-L	Fh	<p>PEG VCO VT Fetch Grant Count (PEGVCOGNTCNT)</p> <p>The arbiter will continue to grant PEG VCO VT fetch as long as the grant count value in this field is greater than zero.</p>
7:4	RW-L	Fh	<p>DMI VCp VT Fetch Grant Count (DMIVCPGNTCNT)</p> <p>The arbiter will continue to grant DMI VCp VT fetch as long as the grant count value in this field is greater than zero and there is no higher priority VT fetch request. Arbitration will switch to PEG VCO VT fetch request if the grant count corresponding to PEG VCO VT fetch is greater than zero and the VT fetch request corresponding to PEG VCO stream is available.</p>
3:0	RW-L	Fh	<p>DMI VCO VT Fetch Grant Count. (DMIVCOGNTCNT)</p> <p>The arbiter will continue to grant DMI VCO VT fetch as long as the grant count value in this field is greater than zero and there is no higher priority VT fetch requests. Arbitration will switch to DMI VCp or PEG VCO VT fetch requests if the grant count corresponding to those VT fetch is greater than zero and the VT fetch requests corresponding to those streams are available.</p>



2.15.33 PEGVTCMPLRESR—PEG VT Completion Resource Dedication

This register provides a programmable interface to dedicate the PEG0 and PEG1 Completion Tracking Queue resources to PEG0 VCO read, PEG0 VCO write, PEG1 VCO read and PEG1 VCO write VT fetch.

B/D/F/Type:		0/0/0/VCOPREMAP	
Address Offset:		F08–F0Bh	
Reset Value:		20004000h	
Access:		RW-L, RO	
Bit	Attr	Reset Value	Description
31:30	RW-L	00b	<p>PEG Completion Tracking Queue Resource Sharing Mode (PCTQRSM)</p> <p>11 = PEG1 and PEG0 will each be assigned half of the resources in the Completion Tracking Queue.</p> <p>10 = PEG1 will be assigned all of the resources in the Completion Tracking Queue.</p> <p>01 = PEG0 will be assigned all of the resources in the Completion Tracking Queue.</p> <p>00 = See below for more description for this encoding: If both Device 1 and Device 6 are enabled, PEG1 and PEG0 will each be assigned half of the resources in the Completion Tracking Queue. If Device 6 is enabled and Device 1 is disabled, PEG1 will be assigned all of the resources in the Completion Tracking Queue. If Device 1 is enabled and Device 6 is disabled, PEG0 will be assigned all of the resources in the Completion Tracking Queue. If both Device 1 and Device 6 are disabled, PEG1 and PEG0 will each be assigned half of the resources in the Completion Tracking Queue.</p>
29:25	RO	10000b	<p>PEG1 VT Completion Tracking Queue Resource Available (PEG1VTCTRA)</p> <p>Number of entries available in PEG1 VT Completion Tracking Queue. 1-based. The values programmed in the fields below must not be greater than the value advertised in this field.</p> <p>Note: If device 1 is disabled, the default is 10000b; otherwise, it is 01000b. This is a status bit.</p>
24:20	RW-L	00000b	<p>PEG1 VCO Write VT Completion Tracking Queue Resource Threshold (PEG1VCOWRCTQRT)</p> <p>This field provides a 1-based minimum threshold value used to throttle PEG1 VCO Write VT fetch. When the number of free PEG1 VT Completion Tracking Queue entries equals or falls below the value programmed in this field, PEG1 VCO Write VT fetch is throttled until the number of free PEG1 Completion Tracking Queue entries rise above this threshold. For example:</p> <p>00000 = Throttle PEG1 VCO Write VT Fetch when there is no entry left. 00001 = Throttle PEG1 VCO Write VT Fetch when there is 1 or less entry left. 00010 = Throttle PEG1 VCO Write VT Fetch when there is 2 or less entry left. 00011 = Throttle PEG1 VCO Write VT Fetch when there is 3 or less entry left. 00100 = Throttle PEG1 VCO Write VT Fetch when there is 4 or less entry left.</p>
19:15	RW-L	00000b	<p>PEG1 VCO Read VT Completion Tracking Queue Resource Threshold (PEG1VCORDCTQRTCT)</p> <p>This field provides a 1-based minimum threshold value used to throttle PEG1 VCO Read VT fetch. When the number of free PEG1 VT Completion Tracking Queue entries equals or falls below the value programmed in this field, PEG1 VCO Read VT fetch is throttled until the number of free PEG1 Completion Tracking Queue entries rise above this threshold. For example:</p> <p>00000 = Throttle PEG1 VCO Read VT Fetch when there is no entry left. 00001 = Throttle PEG1 VCO Read VT Fetch when there is 1 or less entry left. 00010 = Throttle PEG1 VCO Read VT Fetch when there is 2 or less entry left. 00011 = Throttle PEG1 VCO Read VT Fetch when there is 3 or less entry left. 00100 = Throttle PEG1 VCO Read VT Fetch when there is 4 or less entry left.</p>



B/D/F/Type: Address Offset: Reset Value: Access:		0/0/0/VCOPREMAP F08–F0Bh 20004000h RW-L, RO	
Bit	Attr	Reset Value	Description
14:10	RO	10000b	PEGO VT Completion Tracking Queue Resource Available (PEGOVTCTRA) Number of entries available in PEGO VT Completion Tracking Queue. 1-based. The values programmed in the fields below must not be greater than the value advertised in this field. Note: If device 6 is also enabled, the default is 01000b; otherwise, it is 10000b.
9:5	RW-L	00000b	PEGO VCO Write VT Completion Tracking Queue Resource Threshold (PEGOVCOWRCTQRT) This field provides a 1-based minimum threshold value used to throttle PEGO VCO Write VT fetch. When the number of free PEGO VT Completion Tracking Queue entries equals or falls below the value programmed in this field, PEGO VCO Write VT fetch is throttled until the number of free PEGO Completion Tracking Queue entries rise above this threshold. For example: 00000 = Throttle PEGO VCO Write VT Fetch when there is no entry left. 00001 = Throttle PEGO VCO Write VT Fetch when there is 1 or less entry left. 00010 = Throttle PEGO VCO Write VT Fetch when there is 2 or less entry left. 00011 = Throttle PEGO VCO Write VT Fetch when there is 3 or less entry left. 00100 = Throttle PEGO VCO Write VT Fetch when there is 4 or less entry left.
4:0	RW-L	00000b	PEGO VCO Read VT Completion Tracking Queue Resource Threshold (PEGOVCORDCTQRTCT) This field provides a 1-based minimum threshold value used to throttle PEGO VCO Read VT fetch. When the number of free PEGO VT Completion Tracking Queue entries equals or falls below the value programmed in this field, PEGO VCO Read VT fetch is throttled until the number of free PEGO Completion Tracking Queue entries rise above this threshold. For example: 00000 = Throttle PEGO VCO Read VT Fetch when there is no entry left. 00001 = Throttle PEGO VCO Read VT Fetch when there is 1 or less entry left. 00010 = Throttle PEGO VCO Read VT Fetch when there is 2 or less entry left. 00011 = Throttle PEGO VCO Read VT Fetch when there is 3 or less entry left. 00100 = Throttle PEGO VCO Read VT Fetch when there is 4 or less entry left.



2.15.34 VTPOLICY—DMA Remap Engine Policy Control

This registers contains all the policy bits related to the DMA remap engine.

B/D/F/Type:		0/0/0/VCOPREMAP	
Address Offset:		FFC—FFFh	
Reset Value:		0000000h	
Access:		RW-L	
Bit	Attr	Reset Value	Description
31	RW-L	0b	DMA Remap Engine Policy Lock-Down (DMAR_LCKDN) This register bit protects all the DMA remap engine specific policy configuration registers. Once this bit is set by software all the DMA remap engine registers within the range F00h to FFCh will be read-only. This bit can only be clear through platform reset.
30	RW-L	0b	DMA Remap Engine Policy Control (DMAR_CTL) It_gv_vt_scr_reserved_fault_en. 0 = "Default" Hardware support's reserved field programming faults in root, context and page translation structure (that is, fault code of Ah, Bh, Ch). 1 = Hardware ignores reserved field programming faults in the root, context and page translation structure.
29:23	RW-L	00h	Reserved
22	RW-L	0b	Lookup Policy TLB Invalidation (LKUPPOLTLBINVL) VC0/VCp Remap Engine TLB Lookup Policy On TLB Invalidation. 1 = Mask all TLB Lookup to VC0/VCp remap engine during TLB Invalidation Window. 0 = Continue to perform TLB lookup to VC0/VCp remap engine during TLB Invalidation Window. TLB Invalidation Window refers to the period from when the TLB Invalidation is initiated until all the outstanding DMA read and write cycles at the point of TLB Invalidation are initiated are Globally Ordered.
21	RW-L	0b	PEG1 VC0 Read Hit Queue Throttling (PEG1VCORDHTQT) 1 = Throttle the outlet PEG0 VC1 Read Hit Queue to fill up the queue. 0 = No throttling at the outlet of the PEG1 VC0 Read Hit Queue.
20	RW-L	0b	PEG1 VC0 Write Queue Throttling (PEG1VCOWRHTQT) 1 = Throttle the outlet PEG1 VC0 Write Hit Queue to fill up the queue. 0 = No throttling at the outlet of the PEG1 VC0 Write Hit Queue.
19	RW-L	0b	PEG0 VC0 Read Hit Queue Throttling (PEGVCORDHTQT) 1 = Throttle the outlet PEG0 VC0 Read Hit Queue to fill up the queue. 0 = No throttling at the outlet of the PEG0 VC0 Read Hit Queue.
18	RW-L	0b	PEG0 VC0 Write Queue Throttling (PEGVCOWRHTQT) 1 = Throttle the outlet PEG0 VC0 Write Hit Queue to fill up the queue. 0 = No throttling at the outlet of the PEG0 VC0 Write Hit Queue.
17	RW-L	0b	DMI VCp Hit Queue Throttling (DMIVCPHTQT) 1 = Throttle the outlet DMI VCp Hit Queue to fill up the queue. 0 = No throttling at the outlet of the DMI VCp Hit Queue.
16	RW-L	0b	DMI VC0 Read Hit Queue Throttling (DMIVCORDHTQT) 1 = Throttle the outlet DMI VC0 Read Hit Queue to fill up the queue. 0 = No throttling at the outlet of the DMI VC0 Read Hit Queue.
15	RW-L	0b	DMI VC0 Write Queue Throttling (DMIVCOWRHTQT) 1 = Throttle the outlet DMI VC0 Write Hit Queue to fill up the queue. 0 = No throttling at the outlet of the DMI VC0 Write Hit Queue.
14	RW-L	0b	PEG1 Context Cache TLBR (PEG1CTXTLBR) This is a TLBR policy bit for PEG1VC0 Context Cache
13	RW-L	0b	PEG1 L1 TLBR (PEG1L1TLBR) This is a TLBR policy bit for PEG1VC0 L1 Cache



B/D/F/Type: Address Offset: Reset Value: Access:		O/O/O/VCOPREMAP FFC-FFFh 00000000h RW-L	
Bit	Attr	Reset Value	Description
12	RW-L	0b	PEG1 L3 TLBR (PEG1L3TLBR) This is a TLBR policy bit for PEG1VC0 L3 Cache
11	RW-L	0b	PEG1 TLB Disable (PEG1TLBDIS) 1 = PEG1VC0 TLBs are disabled and each GPA request will result in a miss and a root walk will be requested from VTd Dispatcher 0 = Normal mode (default), PEG1VC0 TLBs are enabled and normal hit/miss flows are followed
10	RW-L	0b	DMIVC0TLBDisable (DMIVC0 TLB Disable) 1 = DMIVCOP TLBs are disabled and each GPA request will result in a miss and a root walk will be requested from VTd Dispatcher 0 = Normal mode (default), DMIVCOP TLBs are enabled and normal hit/miss flows are followed
9	RW-L	0b	PEG TLB Disable (PEGTLBDIS) 1 = PEGVC0 TLBs are disabled and each GPA request will result in a miss and a root walk will be requested from VTd Dispatcher 0 = Normal mode (default), PEGVC0 TLBs are enabled and normal hit/miss flows are followed
8	RW-L	0b	PEG Context Cache TLBR (PEGCTXTLBR) This is a TLBR policy bit for PEGVC0 Context Cache
7	RW-L	0b	PEG L1 TLBR (PEGL1TLBR) This is a TLBR policy bit for PEGVC0 L1 Cache
6	RW-L	0b	PEG L3 TLBR (PEGL3TLBR) This is a TLBR policy bit for PEGVC0 L3 Cache
5	RW-L	0b	DMI Context Cache TLBR (DMICTXTLBR) This is a TLBR policy bit for DMIVC0p Context Cache.
4	RW-L	0b	DMI L1 TLBR (DMIL1TLBR) This is a TLBR policy bit for DMIVC0p L1 Cache.
3	RW-L	0b	DMI L3 TLBR (DMIL3TLBR) This is a TLBR policy bit for DMIVC0p L3 Cache.
2	RW-L	0b	Maximum Guest Physical Address Mode (GPAMODE) Maximum Guest Physical Address Mode. This bit is static and will be modified by BIOS only. 1 = 48 bit AGAW mode 0 = 39 bit AGAW mode
1	RW-L	0b	Global IOTLB Invalidation Promotion (GLBIOTLBINV) This bit controls the IOTLB Invalidation behavior of the DMA remap engine. When this bit is set, any type of IOTLB Invalidation (valid or invalid) will be promoted to Global IOTLB Invalidation.
0	RW-L	0b	Global Context Invalidation Promotion (GLBCTXINV) This bit controls the Context Invalidation behavior of the DMA remap engine. When this bit is set, any type of Context Invalidation (valid or invalid) will be promoted to Global Context Invalidation.



2.16 DMI VC1 REMAP Registers

Table 2-12. DMI VC1 Remap Register Address Map

Address Offset	Register Symbol	Register Name	Reset Value	Access
0–3h	VER_REG	Version Register	00000010h	RO
8–Fh	CAP_REG	Capability Register	00C9008020E30272h	RO
10–17h	ECAP_REG	Extended Capability Register	0000000000001000h	RO
18–1Bh	GCMD_REG	Global Command Register	00000000h	W, RO
1C–1Fh	GSTS_REG	Global Status Register	00000000h	RO
20–27h	RTADDR_REG	Root-Entry Table Address Register	0000000000000000h	RW, RO
28–2Fh	CCMD_REG	Context Command Register	0000000000000000h	RW-SC, RW, RO, W
34–37h	FSTS_REG	Fault Status Register	00000000h	RW1C-S, RO-V-S, RO
38–3Bh	FECTL_REG	Fault Event Control Register	80000000h	RW, RO
3C–3Fh	FEDATA_REG	Fault Event Data Register	00000000h	RO, RW
40–43h	FEADDR_REG	Fault Event Address Register	00000000h	RW, RO
44–47h	FEUADDR_REG	Fault Event Upper Address Register	00000000h	RO
58–5Fh	AFLOG_REG	Advanced Fault Log Register	0000000000000000h	RO
64–67h	PMEN_REG	Protected Memory Enable Register	00000000h	RW, RO
68–6Bh	PLMBASE_REG	Protected Low-Memory Base Register	00000000h	RW, RO
6C–6Fh	PLMLIMIT_REG	Protected Low-Memory Limit Register	00000000h	RW, RO
70–77h	PHMBASE_REG	Protected High-Memory Base Register	0000000000000000h	RW, RO
78–7Fh	PHMLIMIT_REG	Protected High-Memory Limit Register	0000000000000000h	RW, RO
80–87h	IQH_REG	Invalidation Queue Head Register	0000000000000000h	RO
88–8Fh	IQT_REG	Invalidation Queue Tail Register	0000000000000000h	RO
90–97h	IQA_REG	Invalidation Queue Address Register	0000000000000000h	RO
9C–9Fh	ICS_REG	Invalidation Completion Status Register	00000000h	RO
A0–A3h	IECTL_REG	Invalidation Event Control Register	00000000h	RO
A4–A7h	IEDATA_REG	Invalidation Event Data Register	00000000h	RO
A8–ABh	IEADDR_REG	Invalidation Event Address Register	00000000h	RO
AC–AFh	IEUADDR_REG	Invalidation Event Upper Address Register	00000000h	RO
B8–BFh	IRTA_REG	Interrupt Remapping Table Address Register	0000000000000000h	RO
100–107h	IVA_REG	Invalidate Address Register	0000000000000000h	W, RO
108–10Fh	IOTLB_REG	IOTLB Invalidate Register	0000000000000000h	RO, RW, RW-SC
200–20Fh	FRCD_REG	Fault Recording Registers	0000000000000000 0000000000000000h	RW1C-S, RO-V-S, RO
FFC–FFFh	VTPOLICY	DMA Remap Engine Policy Control	00000000h	RO, RW-L-K, RW-L



2.16.1 VER_REG—Version Register

This register reports the architecture version supported. Backward compatibility for the architecture is maintained with new revision numbers, allowing software to load DMA-remapping drivers written for prior architecture versions.

B/D/F/Type:		0/0/0/DMIVC1REMAP	
Address Offset:		0–3h	
Reset Value:		00000010h	
Access:		RO	
Bit	Attr	Reset Value	Description
31:8	RO	000000h	Reserved
7:4	RO	1h	Major Version number (MAX) Indicates supported architecture version.
3:0	RO	0h	Minor Version number (MIN) Indicates supported architecture minor version.



2.16.2 CAP_REG—Capability Register

This register reports general DMA remapping hardware capabilities.

B/D/F/Type:		0/0/0/DMIVC1REMAP	
Address Offset:		8–Fh	
Reset Value:		00C9008020E30272h	
Access:		RO	
Bit	Attr	Reset Value	Description
63:56	RO	00h	Reserved
55	RO	1b	DMA Read Draining (DRD) 0 = On IOTLB invalidations, hardware does not support draining of DMA read requests. 1 = On IOTLB invalidations, hardware supports draining of DMA read requests. Refer to VTd specification Section 6.3 for description of DMA draining.
54	RO	1b	DMA Write Draining (DWD) 0 = On IOTLB invalidations, hardware does not support draining of DMA writes. 1 = On IOTLB invalidations, hardware supports draining of DMA writes. Refer to VTd specification Section 6.3 for description of DMA draining.
53:48	RO	09h	Maximum Address Mask Value (MAMV) The value in this field indicates the maximum supported value for the Address Mask (AM) field in the Invalidation Address (IVA_REG) register. This field is valid only when the PSI field is reported as Set.
47:40	RO	00h	Number of Fault Recording Registers (NFR) This field indicates a value of N-1, where N is the number of fault recording registers supported by hardware. Implementations must support at least one fault recording register (NFR = 0) for each DMA-remapping hardware unit in the platform. The maximum number of fault recording registers per DMA-remapping hardware unit is 256.
39	RO	1b	Page Selective Invalidation Support (PSI) 0 = Hardware supports only domain and global invalidates for IOTLB. 1 = Hardware supports page selective, domain, and global invalidates for IOTLB and hardware must support a minimum MAMV value of 9.
38	RO	0b	Reserved
37:34	RO	0h	Super Page Support (SPS) This field indicates the super page sizes supported by hardware. A value of 1 in any of these bits indicates the corresponding super-page size is supported. The super-page sizes corresponding to various bit positions within this field are: 0 = 21-bit offset to page frame 1 = 30-bit offset to page frame 2 = 39-bit offset to page frame 3 = 48-bit offset to page frame Hardware implementations supporting a specific super-page size must support all smaller superpage sizes. That is, the only valid values for this field are 0001b, 0011b, 0111b, 1111b.
33:24	RO	020h	Fault-recording Register Offset (FRO) This field specifies the location to the first fault recording register relative to the register base address of this DMA-remapping hardware unit. If the register base address is X, and the value reported in this field is Y, the address for the first fault recording register is calculated as X+(16*Y).



B/D/F/Type: Address Offset: Reset Value: Access:		0/0/0/DMIVC1REMAP 8–Fh 00C9008020E30272h RO	
Bit	Attr	Reset Value	Description
23	RO	1b	<p>Isochrony (Isoch)</p> <p>0 = Indicates this DMA-remapping hardware unit has no critical isochronous requesters in its scope.</p> <p>1 = Indicates this DMA-remapping hardware unit has one or more critical isochronous requesters in its scope. To ensure isochronous performance, software must ensure invalidation operations do not impact active DMA streams from such requesters. This implies that when DMA is active, software perform page-selective invalidations (instead of coarser invalidations).</p>
22	RO	1b	<p>Zero Length Read (ZLR)</p> <p>0 = Indicates the remapping hardware unit blocks (and treats as fault) zero length DMA read requests to write-only pages.</p> <p>1 = Indicates the remapping hardware unit supports zero length DMA read requests to write-only pages.</p>
21:16	RO	23h	<p>Maximum Guest Address Width (MGAW)</p> <p>This field indicates the maximum DMA virtual addressability supported by remapping hardware.</p> <p>The Maximum Guest Address Width (MGAW) is computed as $(N+1)$, where N is the value reported in this field. For example, a hardware implementation supporting 48-bit MGAW reports a value of 47 (101111b = 2Fh) in this field. If the value in this field is X, DMA requests to addresses above $2^{(x+1)}-1$ are always blocked by hardware.</p> <p>Guest addressability for a given DMA request is limited to the minimum of the value reported through this field and the adjusted guest address width of the corresponding page-table structure. (Adjusted guest address widths supported by hardware are reported through the SAGAW field).</p> <p>Implementations are recommended to support MGAW at least equal to the physical addressability (host address width) of the platform.</p>
15:13	RO	000b	Reserved
12:8	RO	02h	<p>Supported Adjusted Guest Address Widths (SAGAW)</p> <p>This 5-bit field indicates the supported adjusted guest address widths (which in turn represents the levels of page-table walks for the 4 KB page size) supported by the hardware implementation.</p> <p>A value of 1 in any of these bits indicates the corresponding adjusted guest address width is supported. The adjusted guest address widths corresponding to various bit positions within this field are:</p> <p>0 = 30-bit AGAW (2-level page table) 1 = 39-bit AGAW (3-level page table) 2 = 48-bit AGAW (4-level page table) 3 = 57-bit AGAW (5-level page table) 4 = 64-bit AGAW (6-level page table)</p> <p>Software must ensure that the adjusted guest address width used to setup the page tables is one of the supported guest address widths reported in this field.</p>
7	RO	0b	<p>Caching Mode (CM)</p> <p>0 = Hardware does not cache not present and erroneous entries in any of the remapping caches. Invalidations are not required for modifications to individual not present or invalid entries. However, any modifications that result in decreasing the effective permissions or partial permission increases require invalidations for them to be effective.</p> <p>1 = Hardware may cache not present and erroneous mappings in the remapping caches. Any software updates to the DMA-remapping structures (including updates to not-present or erroneous entries) require explicit invalidation.</p> <p>Refer to the VTd specification for more details on caching mode. Hardware implementations are required to support operation corresponding to CM=0.</p>



B/D/F/Type:		0/0/0/DMIVC1REMAP	
Address Offset:		8–Fh	
Reset Value:		00C9008020E30272h	
Access:		RO	
Bit	Attr	Reset Value	Description
6	RO	1b	Protected High-Memory Region (PHMR) 0 = Protected high-memory region not supported. 1 = Protected high-memory region is supported.
5	RO	1b	Protected Low-Memory Region (PLMR) 0 = Protected low-memory region not supported. 1 = Protected low-memory region is supported.
4	RO	1b	Required Write-Buffer Flushing (RWBF) 0 = No write-buffer flushing needed to ensure changes to memory-resident structures are visible to hardware. 1 = Software must explicitly flush the write buffers to ensure updates made to memory-resident DMA-remapping structures are visible to hardware. Refer to the VTd specification for more details on write buffer flushing requirements.
3	RO	0b	Advanced Fault Logging (AFL) 0 = Advanced fault logging not supported. Only primary fault logging is supported. 1 = Advanced fault logging is supported.
2:0	RO	010b	Number of domains supported (ND) 000b = Hardware supports 4-bit domain-ids with support for up to 16 domains. 001b = Hardware supports 6-bit domain-ids with support for up to 64 domains. 010b = Hardware supports 8-bit domain-ids with support for up to 256 domains. 011b = Hardware supports 10-bit domain-ids with support for up to 1024 domains. 100b = Hardware supports 12-bit domain-ids with support for up to 4K domains. 100b = Hardware supports 14-bit domain-ids with support for up to 16K domains. 110b = Hardware supports 16-bit domain-ids with support for up to 64K domains. 111b =Reserved.

2.16.3 ECAP_REG—Extended Capability Register

This register reports DMA-remapping hardware extended capabilities.

B/D/F/Type:		0/0/0/DMIVC1REMAP	
Address Offset:		10–17h	
Reset Value:		0000000000001000h	
Access:		RO	
Bit	Attr	Reset Value	Description
63:24	RO	00000000 00h	Reserved
23:20	RO	0h	Maximum Handle Mask Value (MHMV) The value in this field indicates the maximum supported value for the Handle Mask (HM) field in the interrupt entry cache invalidation descriptor (iec_inv_dsc). This field is valid only when the IR field is reported as set to 1.
19:18	RO	00b	Reserved



B/D/F/Type:		O/O/O/DMIVC1REMAP	
Address Offset:		10–17h	
Reset Value:		000000000001000h	
Access:		RO	
Bit	Attr	Reset Value	Description
17:8	RO	010h	Invalidation Unit Offset (IVO) This field specifies the location to the first IOTLB registers relative to the register base address of this DMA-remapping hardware unit. If the register base address is X, and the value reported in this field is Y, the address for the first IOTLB register is calculated as X+(16*Y).
7	RO	0b	Snoop Control (SC) 0 = Hardware does not support setting the SNP field to '1' in the page-table entries. 1 = Hardware supports setting the SNP field to '1' in the page-table entries.
6	RO	0b	Pass Through (PT) 0 = Hardware does not support pass-through translation type in context entries. 1 = Hardware supports pass-through translation type in context entries.
5	RO	0b	Caching Hints (CH) 0 = Hardware does not support IOTLB caching hints (ALH and EH fields in context-entries are treated as reserved). 1 = Hardware supports IOTLB caching hints through the ALH and EH fields in context-entries.
4	RO	0b	Extended Interrupt Mode (EIM) 0 = On Intel 64 platforms, hardware supports only 8-bit APIC-IDs (xAPIC Mode). 1 = On Intel 64 platforms, hardware supports 32-bit APIC-IDs (x2APIC mode). The processor supports 16-bit APICIDs and always report this field as 0. This field is valid only when the IR field is reported as Set.
3	RO	0b	Interrupt Remapping Support (IR) 0 = Hardware does not support interrupt remapping. 1 = Hardware supports interrupt remapping. Implementations reporting this field as Set must also support Queued Invalidation (QI = 1b).
2	RO	0b	Device IOTLB Support (DI) 0 = Hardware does not support device-IOTLBs. 1 = Hardware supports Device-IOTLBs. Implementations reporting this field as Set must also support Queued Invalidation (QI = 1b).
1	RO	0b	Queued Invalidation Support (QI) 0 = Hardware does not support queued invalidations. 1 = Hardware supports queued invalidations.
0	RO	0b	Coherency (C) This field indicates if hardware access to the root, context, page-table and interrupt remap structures are coherent (snooped) or not. 0 = Indicates hardware accesses to remapping structures are noncoherent. 1 = Indicates hardware accesses to remapping structures are coherent. Hardware access to advanced fault log and invalidation queue are always coherent.

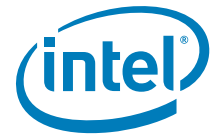

2.16.4 GCMD_REG—Global Command Register

This register controls DMA-remapping hardware. If multiple control fields in this register need to be modified, software must serialize the modifications through multiple writes to this register.

B/D/F/Type:		0/0/0/DMIVC1REMAP	
Address Offset:		18–1Bh	
Reset Value:		0000000h	
Access:		W, RO	
Bit	Attr	Reset Value	Description
31	W	0b	<p>Translation Enable (TE)</p> <p>Software writes to this field to request hardware to enable/disable DMA-remapping hardware.</p> <p>0 = Disable DMA-remapping 1 = Enable DMA-remapping</p> <p>Hardware reports the status of the translation enable operation through the TES field in the Global Status register.</p> <p>There may be active DMA requests in the platform when software updates this field. Hardware must enable or disable remapping logic only at deterministic transaction boundaries, so that any in-flight transaction is either subject to remapping or not at all.</p> <p>Hardware implementations supporting DMA draining must drain any in-flight DMA read/write requests queued within the root complex before completing the translation enable command and reflecting the status of the command through the TES field in the GSTS_REG.</p> <p>Value returned on read of this field is undefined.</p>
30	W	0b	<p>Set Root Table Pointer (SRTP)</p> <p>Software sets this field to set/update the root-entry table pointer used by hardware. The root-entry table pointer is specified through the Root-entry Table Address register.</p> <p>Hardware reports the status of the root table pointer set operation through the RTPS field in the Global Status register.</p> <p>The root table pointer set operation must be performed before enabling or re-enabling (after disabling) DMA-remapping through the TE field.</p> <p>After a root table pointer set operation, software must globally invalidate the context cache followed by global invalidate of IOTLB. This is required to ensure hardware uses only the remapping structures referenced by the new root table pointer, and not any stale cached entries.</p> <p>While DMA-remapping hardware is active, software may update the root table pointer through this field.</p> <p>However, to ensure valid in-flight DMA requests are deterministically remapped, software must ensure that the structures referenced by the new root table pointer are programmed to provide the same remapping results as the structures referenced by the previous root table pointer.</p> <p>Clearing this bit has no effect.</p> <p>Value returned on read of this field is undefined.</p>
29	W	0b	<p>Set Fault Log (SFL)</p> <p>This field is valid only for implementations supporting advanced fault logging. Software sets this field to request hardware to set/update the fault-log pointer used by hardware. The fault-log pointer is specified through Advanced Fault Log register.</p> <p>Hardware reports the status of the fault log set operation through the FLS field in the Global Status register.</p> <p>The fault log pointer must be set before enabling advanced fault logging (through EAFL field). Once advanced fault logging is enabled, the fault log pointer may be updated through this field while DMA-remapping is active. Clearing this bit has no effect.</p> <p>Value returned on read of this field is undefined.</p>

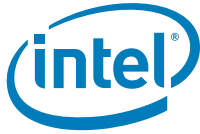

B/D/F/Type: Address Offset: Reset Value: Access:		0/0/0/DMIVC1REMAP 18–1Bh 00000000h W, RO	
Bit	Attr	Reset Value	Description
28	W	0b	<p>Enable Advanced Fault Logging (EAFL)</p> <p>This field is valid only for implementations supporting advanced fault logging. Software writes to this field to request hardware to enable or disable advanced fault logging.</p> <p>0 = Disable advanced fault logging. In this case, translation faults are reported through the Fault Recording registers. 1 = Enable use of memory-resident fault log. When enabled, translation faults are recorded in the memory-resident log. The fault log pointer must be set in hardware (through SFL field) before enabling advanced fault logging.</p> <p>Hardware reports the status of the advanced fault logging enable operation through the AFLS field in the Global Status register. Value returned on read of this field is undefined.</p>
27	W	0b	<p>Write Buffer Flush (WBF)</p> <p>This bit is valid only for implementations requiring write buffer flushing. Software sets this field to request hardware to flush the root-complex internal write buffers. This is done to ensure any updates to the memory-resident DMA-remapping structures are not held in any internal write posting buffers. Refer to the VTd specification for details on write-buffer flushing requirements.</p> <p>Hardware reports the status of the write buffer flushing operation through the WBFS field in the Global Status register. Clearing this bit has no effect. Value returned on read of this field is undefined.</p>
26	RO	0b	<p>Queued Invalidation Enable (QIE)</p> <p>This field is valid only for implementations supporting queued invalidations. Software writes to this field to enable or disable queued invalidations.</p> <p>0 = Disable queued invalidations. 1 = Enable use of queued invalidations.</p> <p>Hardware reports the status of queued invalidation enable operation through QIES field in the Global Status register. Refer to the VTd specification for software requirements for enabling/disabling queued invalidations. The value returned on a read of this field is undefined.</p>
25	RO	0b	<p>Interrupt Remapping Enable (IRE)</p> <p>This field is valid only for implementations supporting interrupt remapping.</p> <p>0 = Disable interrupt-remapping hardware 1 = Enable interrupt-remapping hardware</p> <p>Hardware reports the status of the interrupt remapping enable operation through the IRES field in the Global Status register.</p> <p>There may be active interrupt requests in the platform when software updates this field. Hardware must enable or disable interrupt-remapping logic only at deterministic transaction boundaries, so that any in-flight interrupts are either subject to remapping or not at all.</p> <p>Hardware implementations must drain any in-flight interrupts requests queued in the Root-Complex before completing the interrupt-remapping enable command and reflecting the status of the command through the IRES field in the Global Status register. The value returned on a read of this field is undefined.</p>

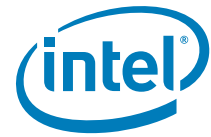

B/D/F/Type: Address Offset: Reset Value: Access:		0/0/0/DMIVC1REMAP 18–1Bh 00000000h W, RO	
Bit	Attr	Reset Value	Description
24	RO	0b	<p>Set Interrupt Remap Table Pointer (SIRTP)</p> <p>This field is valid only for implementations supporting interrupt-remapping. Software sets this field to set/update the interrupt remapping table pointer used by hardware. The interrupt remapping table pointer is specified through the Interrupt Remapping Table Address register.</p> <p>Hardware reports the status of the interrupt remapping table pointer set operation through the IRTPS field in the Global Status register. The interrupt remap table pointer set operation must be performed before enabling or re-enabling (after disabling) interrupt-remapping hardware through the IRE field.</p> <p>After an interrupt remap table pointer set operation, software must globally invalidate the interrupt entry cache. This is required to ensure hardware uses only the interrupt-remapping entries referenced by the new interrupt remap table pointer, and not any stale cached entries.</p> <p>While interrupt remapping is active, software may update the interrupt remapping table pointer through this field. However, to ensure valid in-flight interrupt requests are deterministically remapped, software must ensure that the structures referenced by the new interrupt remap table pointer are programmed to provide the same remapping results as the structures referenced by the previous interrupt remap table pointer.</p> <p>Clearing this bit has no effect. The value returned on a read of this field is undefined.</p>
23	RO	0b	<p>Compatibility Format Interrupt (CFI)</p> <p>This field is valid only for Intel 64 implementations supporting interrupt-remapping. Software writes to this field to enable or disable Compatibility Format interrupts on Intel 64 platforms. The value in this field is effective only when interrupt-remapping is enabled and Extended Interrupt Mode (x2APIC mode) is disabled.</p> <p>0 = Block Compatibility format interrupts. 1 = Process Compatibility format interrupts as pass-through (bypass interrupt remapping).</p> <p>Hardware reports the status of updating this field through the CFIS field in the Global Status register.</p> <p>Refer to the VTd specification for details on Compatibility Format interrupt requests.</p> <p>The value returned on a read of this field is undefined. This field is not implemented.</p>
22:0	RO	000000h	Reserved



2.16.5 GSTS_REG—Global Status Register

This register reports general DMA-remapping hardware status.

B/D/F/Type:		0/0/0/DMIVC1REMAP	
Address Offset:		1C–1Fh	
Reset Value:		0000000h	
Access:		RO	
Bit	Attr	Reset Value	Description
31	RO	0b	Translation Enable Status (TES) This field indicates the status of DMA-remapping hardware. 0 = DMA-remapping hardware is not enabled 1 = DMA-remapping hardware is enabled
30	RO	0b	Root Table Pointer Status (RTPS) This field indicates the status of the root-table pointer in hardware. This field is cleared by hardware when software sets the SRTP field in the Global Command register. This field is set by hardware when hardware completes the set root-table pointer operation using the value provided in the Root-Entry Table Address register.
29	RO	0b	Fault Log Status (FLS) This field is cleared by hardware when software sets the SFL field in the Global Command register. This field is set by hardware when hardware completes the set fault-log pointer operation using the value provided in the Advanced Fault Log register.
28	RO	0b	Advanced Fault Logging Status (AFLS) This field is valid only for implementations supporting advanced fault logging. This field indicates advanced fault logging status. 0 = Advanced Fault Logging is not enabled 1 = Advanced Fault Logging is enabled
27	RO	0b	Write Buffer Flush Status (WBFS) This bit is valid only for implementations requiring write buffer flushing. This field indicates the status of the write buffer flush operation. This field is set by hardware when software sets the WBF field in the Global Command register. This field is cleared by hardware when hardware completes the write buffer flushing operation.
26	RO	0b	Queued Invalidation Enable Status (QIES) This field indicates queued invalidation enable status. 0 = queued invalidation is not enabled 1 = queued invalidation is enabled
25	RO	0b	Interrupt Remapping Enable Status (IRES) This field indicates the status of Interrupt-remapping hardware. 0 = Interrupt-remapping hardware is not enabled 1 = Interrupt-remapping hardware is enabled
24	RO	0b	Interrupt Remapping Table Pointer Status (IRTPS) This field indicates the status of the interrupt remapping table pointer in hardware. This field is cleared by hardware when software sets the SIRTP field in the Global Command register. This field is Set by hardware when hardware completes the set interrupt remap table pointer operation using the value provided in the Interrupt Remapping Table Address register.
23	RO	0b	Compatibility Format Interrupt Status (CFIS) This field indicates the status of Compatibility format interrupts on Intel 64 implementations supporting interrupt-remapping. The value reported in this field is applicable only when interrupt-remapping is enabled and extended interrupt mode (x2APIC mode) is disabled. 0 = Compatibility format interrupts are blocked. 1 = Compatibility format interrupts are processed as pass-through (bypassing interrupt remapping).
22:0	RO	000000h	Reserved

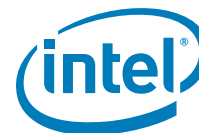

2.16.6 RTADDR_REG—Root-Entry Table Address Register

This register provides the base address of the root-entry table.

B/D/F/Type:		0/0/0/DMIVC1REMAP	
Address Offset:		20–27h	
Reset Value:		0000000000000000h	
Access:		RW, RO	
Bit	Attr	Reset Value	Description
63:12	RW	00000000 00000h	<p>Root Table Address (RTA)</p> <p>This register points to base of page aligned, 4 KB-sized root-entry table in system memory. Hardware may ignore and not implement bits 63:HAW, where HAW is the host address width.</p> <p>Software specifies the base address of the root-entry table through this register, and programs it in hardware through the SRTF field in the Global Command register.</p> <p>Reads of this register returns value that was last programmed to it.</p>
11:0	RO	000h	Reserved



2.16.7 CCMD_REG—Context Command Register

This register manages context cache. The act of writing the uppermost byte of the CCMD_REG with ICC field set causes the hardware to perform the context-cache invalidation.

B/D/F/Type: 0/0/0/DMIVC1REMAP Address Offset: 28–2Fh Reset Value: 0000000000000000h Access: RW-SC, RW, RO, W			
Bit	Attr	Reset Value	Description
63	RW-SC	0b	<p>Invalidate Context-Cache (ICC)</p> <p>Software requests invalidation of context-cache by setting this field. Software must also set the requested invalidation granularity by programming the CIRG field.</p> <p>Software must read back and check the ICC field to be clear to confirm the invalidation is complete. Software must not update this register when this field is set.</p> <p>Hardware clears the ICC field to indicate the invalidation request is complete. Hardware also indicates the granularity at which the invalidation operation was performed through the CAIG field. Software must not submit another invalidation request through this register while the ICC field is set.</p> <p>Software must submit a context cache invalidation request through this field only when there are no invalidation requests pending at this DMA-remapping hardware unit. Refer to the VTd specification for software programming requirements.</p> <p>Since information from the context-cache may be used by hardware to tag IOTLB entries, software must perform domain-selective (or global) invalidation of IOTLB after the context cache invalidation has completed.</p> <p>Hardware implementations reporting write-buffer flushing requirement (RWBF=1 in Capability register) must implicitly perform a write buffer flush before invalidating the context-cache.</p> <p>Refer to the VTd specification for write buffer flushing requirements.</p>
62:61	RW	00b	<p>Context Invalidation Request Granularity (CIRG)</p> <p>Software provides the requested invalidation granularity through this field when setting the ICC field.</p> <p>Following are the encodings for the CIRG field:</p> <p>00 = Reserved.</p> <p>01 = Global Invalidation request.</p> <p>10 = Domain-selective invalidation request. The target domain-id must be specified in the DID field.</p> <p>11 = Device-selective invalidation request. The target source-id(s) must be specified through the SID and FM fields, and the domain-id (that was programmed in the context-entry for these device(s)) must be provided in the DID field.</p> <p>Hardware implementations may process an invalidation request by performing invalidation at a coarser granularity than requested. Hardware indicates completion of the invalidation request by clearing the ICC field. At this time, hardware also indicates the granularity at which the actual invalidation was performed through the CAIG field.</p>

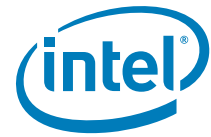

B/D/F/Type: Address Offset: Reset Value: Access:		0/0/0/DMI VC1REMAP 28–2Fh 0000000000000000h RW-SC, RW, RO, W	
Bit	Attr	Reset Value	Description
60:59	RO	00b	Context Actual Invalidation Granularity (CAIG) Hardware reports the granularity at which an invalidation request was processed through the CAIG field at the time of reporting invalidation completion (by clearing the ICC field). The following are the encodings for the CAIG field: 00 = Reserved. 01 = Global Invalidation performed. This could be in response to a global, domain-selective or device-selective invalidation request. 10 = Domain-selective invalidation performed using the domain-id specified by software in the DID field. This could be in response to a domain-selective or device-selective invalidation request. 11 = Device-selective invalidation performed using the source-id and domain-id specified by software in the SID and FM fields. This can only be in response to a device-selective invalidation request.
58:34	RO	0000000h	Reserved
33:32	W	00b	Function Mask (FM) Software may use the Function Mask to perform device-selective invalidations on behalf of devices supporting PCI Express Phantom Functions. This field specifies which bits of the function number portion (least significant three bits) of the SID field to mask when performing device-selective invalidations. The following encodings are defined for this field: 00 = No bits in the SID field masked. 01 = Mask most significant bit of function number in the SID field. 10 = Mask two most significant bit of function number in the SID field. 11 = Mask all three bits of function number in the SID field. The context-entries corresponding to all the source-ids specified through the FM and SID fields must have the domain-id specified in the DID field. Value returned on read of this field is undefined.
31:16	W	0000h	Source ID (SID) Indicates the source-id of the device whose corresponding context-entry needs to be selectively invalidated. This field along with the FM field must be programmed by software for device-selective invalidation requests. Value returned on read of this field is undefined.
15:0	RW	0000h	Domain-ID (DID) Indicates the ID of the domain whose context-entries needs to be selectively invalidated. This field must be programmed by software for both domain-selective and device-selective invalidation requests. The Capability register reports the domain-id width supported by hardware. Software must ensure that the value written to this field is within this limit. Hardware may ignore and not implement bits 15:N where N is the supported domain-id width reported in the capability register.



2.16.8 FSTS_REG—Fault Status Register

This register indicates the various error status.

B/D/F/Type:		0/0/0/DMIVC1REMAP	
Address Offset:		34–37h	
Reset Value:		0000000h	
Access:		RW1C-S, RO-V-S, RO	
Bit	Attr	Reset Value	Description
31:16	RO	0000h	Reserved
15:8	RO-V-S	00h	<p>Fault Record Index (FRI)</p> <p>This field is valid only when the PPF field is set.</p> <p>The FRI field indicates the index (from base) of the fault recording register to which the first pending fault was recorded when the PPF field was set by hardware.</p> <p>The value read from this field is undefined when the PPF field is clear.</p>
7	RO	0b	Reserved
6	RW1C-S	0b	<p>Invalidation Time-out Error (ITE)</p> <p>Hardware detected a Device-IOTLB invalidation completion time-out. At this time, a fault event may be generated based on the programming of the Fault Event Control register.</p> <p>Hardware implementations not supporting Device-IOTLBs implement this bit as reserved.</p>
5	RW1C-S	0b	<p>Invalidation Completion Error (ICE)</p> <p>Hardware received an unexpected or invalid Device-IOTLB invalidation completion. This could be due to either an invalid ITag or invalid source-id in an invalidation completion response. At this time, a fault event may be generated based on the programming of the Fault Event Control register.</p> <p>Hardware implementations not supporting Device-IOTLBs implement this bit as reserved.</p>
4	RO	0b	<p>Invalidation Queue Error (IQE)</p> <p>Hardware detected an error associated with the invalidation queue. This could be due to either a hardware error while fetching a descriptor from the invalidation queue, or hardware detecting an erroneous or invalid descriptor in the invalidation queue. At this time, a fault event may be generated based on the programming of the Fault Event Control register.</p> <p>Hardware implementations not supporting queued invalidations implement this bit as reserved.</p>
3	RW1C-S	0b	<p>Advanced Pending Fault (APF)</p> <p>When this field is Clear, hardware sets this field when the first fault record (at index 0) is written to a fault log. At this time, a fault event is generated based on the programming of the Fault Event Control register.</p> <p>Software writing 1 to this field clears it. Hardware implementations not supporting advanced fault logging implement this bit as reserved.</p>
2	RW1C-S	0b	<p>Advanced Fault Overflow (AFO)</p> <p>Hardware sets this field to indicate advanced fault log overflow condition. At this time, a fault event is generated based on the programming of the Fault Event Control register.</p> <p>Software writing 1 to this field clears it. Hardware implementations not supporting advanced fault logging implement this bit as reserved.</p>
1	RO-V-S	0b	<p>Primary Pending Fault (PPF)</p> <p>This field indicates if there are one or more pending faults logged in the fault recording registers. Hardware computes this field as the logical OR of Fault (F) fields across all the fault recording registers of this DMA-remapping HW unit.</p> <p>0 = No pending faults in any of the fault recording registers. 1 = One or more fault recording registers has pending faults.</p> <p>The FRI field is updated by hardware whenever the PPF field is set by hardware. Also, depending on the programming of Fault Event Control register, a fault event is generated when hardware sets this field.</p>
0	RW1C-S	0b	<p>Primary Fault Overflow (PFO)</p> <p>Hardware sets this field to indicate overflow of fault recording registers. Software writing 1 clears this field. When this field is set, hardware does not record any new faults until software clears this field.</p>

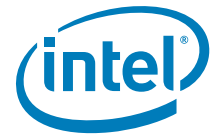

2.16.9 FECTL_REG—Fault Event Control Register

This register specifies the fault event interrupt message control bits. The VTd specification describes hardware handling of fault events.

B/D/F/Type:		0/0/0/DMIVC1REMAP	
Address Offset:		38-3Bh	
Reset Value:		8000000h	
Access:		RW, RO	
Bit	Attr	Reset Value	Description
31	RW	1b	<p>Interrupt Mask (IM)</p> <p>0 = No masking of interrupt. When a interrupt condition is detected, hardware issues an interrupt message (using the Fault Event Data & Fault Event Address register values).</p> <p>1 = This is the value on reset. Software may mask interrupt message generation by setting this field. Hardware is prohibited from sending the interrupt message when this field is set.</p>
30	RO	0b	<p>Interrupt Pending (IP)</p> <p>Hardware sets the IP field whenever it detects an interrupt condition, which is defined as:</p> <ul style="list-style-type: none"> When primary fault logging is active, an interrupt condition occurs when hardware records a fault through one of the Fault Recording registers and sets the PPF field in the Fault Status register. When advanced fault logging is active, an interrupt condition occurs when hardware records a fault in the first fault record (at index 0) of the current fault log and sets the APF field in the Fault Status register. Hardware detected error associated with the Invalidation Queue, setting the IQE field in the Fault Status register. Hardware detected invalid Device-IOTLB invalidation completion, setting the ICE field in the Fault Status register. Hardware detected Device-IOTLB invalidation completion time-out, setting the ITE field in the Fault Status register. <p>If any of the status fields in the Fault Status register was already Set at the time of setting any of these fields, it is not treated as a new interrupt condition.</p> <p>The IP field is kept Set by hardware while the interrupt message is held pending. The interrupt message could be held pending due to the interrupt mask (IM field) being Set or other transient hardware conditions.</p> <p>The IP field is cleared by hardware as soon as the interrupt message pending condition is serviced.</p> <p>This could be due to either:</p> <ul style="list-style-type: none"> Hardware issuing the interrupt message due to either a change in the transient hardware condition that caused the interrupt message to be held pending, or due to software clearing the IM field. Software servicing all the pending interrupt status fields in the Fault Status register as follows. <ul style="list-style-type: none"> When primary fault logging is active, software clearing the Fault (F) field in all the Fault Recording registers with faults, causing the PPF field in the Fault Status register to be evaluated as Clear. Software clearing other status fields in the Fault Status register by writing back the value read from the respective fields.
29:0	RO	00..00h	Reserved



2.16.10 FEDATA_REG—Fault Event Data Register

This register specifies the interrupt message data.

B/D/F/Type:		0/0/0/DMIVC1REMAP	
Address Offset:		3C–3Fh	
Reset Value:		00000000h	
Access:		RO, RW	
Bit	Attr	Reset Value	Description
31:16	RO	0000h	Extended Interrupt Message Data (EIMD) This field is valid only for implementations supporting 32-bit MSI data fields. Hardware implementations supporting only 16-bit MSI data may treat this field as read-only (0).
15:0	RW	0000h	Interrupt message Data (ID) Data value in the interrupt request. Software requirements for programming this register are described in the VTd specification.

2.16.11 FEADDR_REG—Fault Event Address Register

This Register specifies the interrupt message address.

B/D/F/Type:		0/0/0/DMIVC1REMAP	
Address Offset:		40–43h	
Reset Value:		00000000h	
Access:		RW, RO	
Bit	Attr	Reset Value	Description
31:2	RW	00000000h	Message Address (MA) When fault events are enabled, the contents of this register specify the DWORD aligned address (bits 31:2) for the interrupt request. Software requirements for programming this register are described in the VTd specification.
1:0	RO	00b	Reserved



2.16.12 FEUADDR_REG—Fault Event Upper Address Register

This register specifies the interrupt message upper address. The register is treated as reserved by implementations reporting Extended Interrupt Mode (EIM) as not supported in the Extended Capability register.

B/D/F/Type:		0/0/0/DMIVC1REMAP	
Address Offset:		44–47h	
Reset Value:		00000000h	
Access:		RO	
Bit	Attr	Reset Value	Description
31:0	RO	00000000h	<p>Message Upper Address (MUA) Hardware implementations supporting Extended Interrupt Mode are required to implement this register. Software requirements for programming this register are described in the VTd specification. Hardware implementations not supporting Extended Interrupt Mode may treat this field as reserved.</p>

2.16.13 AFLOG_REG—Advanced Fault Log Register

This register specifies the base address of the memory-resident fault-log region. The register is treated as reserved for implementations not supporting advanced translation fault logging (AFL field reported as 0 in the Capability register).

B/D/F/Type:		0/0/0/DMIVC1REMAP	
Address Offset:		58–5Fh	
Reset Value:		0000000000000000h	
Access:		RO	
Bit	Attr	Reset Value	Description
63:12	RO	000000000000h	<p>Fault Log Address (FLA) This field specifies the base of 4KB aligned fault-log region in system memory. Hardware may ignore and not implement bits 63:HAW, where HAW is the host address width. Software specifies the base address and size of the fault log region through this register, and programs it in hardware through the SFL field in the Global Command register. When implemented, reads of this field returns value that was last programmed to it.</p>
11:9	RO	000b	<p>Fault Log Size (FLS) This field specifies the size of the fault log region pointed by the FLA field. The size of the fault log region is $(2^X) * 4KB$, where X is the value programmed in this register. 000 = 4 KB 001 = 8 KB 010 = 16 KB 011 = 32 KB 100 = 64 KB 101 = 128 KB 110 = 256 KB 111 = 512 KB When implemented, reads of this field returns value that was last programmed to it.</p>
8:0	RO	000h	Reserved



2.16.14 PMEN_REG—Protected Memory Enable Register

This register enables the DMA-protected memory regions set up through the PLMBASE, PLMLIMIT, PHMBASE, PHMLIMIT registers. This register is treated as RO for implementations not supporting protected memory regions (PLMR and PHMR fields reported as Clear in the Capability register).

Protected memory regions may be used by software to securely initialize remapping structures in memory.

B/D/F/Type:		0/0/0/DM1VC1REMAP	
Address Offset:		64–67h	
Reset Value:		00000000h	
Access:		RW, RO	
Bit	Attr	Reset Value	Description
31	RW	0b	<p>Enable Protected Memory (EPM)</p> <p>This field controls DMA accesses to the protected low-memory and protected high memory regions.</p> <p>0 = Protected memory regions are disabled. 1 = Protected memory regions are enabled.</p> <p>DMA requests accessing protected memory regions are handled as follows:</p> <p>When DMA remapping is not enabled, all DMA requests accessing protected memory regions are blocked.</p> <p>When DMA remapping is enabled:</p> <p>DMA requests processed as pass-through (Translation Type value of 10b in Context-Entry) and accessing the protected memory regions are blocked.</p> <p>DMA requests with translated address (AT=10b) and accessing the protected memory regions are blocked.</p> <p>DMA requests that are subject to address remapping, and accessing the protected memory regions may or may not be blocked by hardware. For such requests, software must not depend on hardware protection of the protected memory regions, and instead program the DMA-remapping page-tables to not allow DMA to protected memory regions.</p> <p>Remapping hardware access to the remapping structures are not subject to protected memory region checks.</p> <p>DMA requests blocked due to protected memory region violation are not recorded or reported as remapping faults.</p> <p>Hardware reports the status of the protected memory enable/disable operation through the PRS field in this register. Hardware implementations supporting DMA draining must drain any in-flight translated DMA requests queued within the Root-Complex before indicating the protected memory region as enabled through the PRS field.</p>
30:1	RO	00..00b	Reserved
0	RO	0b	<p>Protected Region Status (PRS)</p> <p>This field indicates the status of protected memory region.</p> <p>0 = Protected memory region(s) not enabled. 1 = Protected memory region(s) enabled.</p>

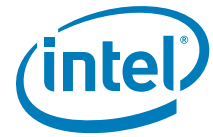

2.16.15 PLMBASE_REG—Protected Low-Memory Base Register

This register is used to set up the base address of DMA-protected low-memory region below 4 GB. This register must be set up before enabling protected memory through PMEN_REG, and must not be updated when protected memory regions are enabled.

This register is treated as RO for implementations not supporting protected low memory region (PLMR field reported as Clear in the Capability register).

The alignment of the protected low memory region base depends on the number of reserved bits (N:0) of this register. Software may determine N by writing all 1s to this register, and finding the most significant bit position with 0 in the value read back from the register. Bits N:0 of this register are decoded by hardware as all 0s.

Software must setup the protected low memory region below 4 GB. The VTd specification describes the Protected Low-Memory Limit register and hardware decoding of these registers.

Software must not modify this register when protected memory regions are enabled. (PRS field Set in PMEN_REG).

B/D/F/Type:		0/0/0/DMIVC1REMAP	
Address Offset:		68–6Bh	
Reset Value:		00000000h	
Access:		RW, RO	
Bit	Attr	Reset Value	Description
31:21	RW	000h	Protected Low-Memory Base (PLMB) This register specifies the base of protected low-memory region in system memory.
20:0	RO	000000h	Reserved



2.16.16 PLMLIMIT_REG—Protected Low-Memory Limit Register

This register is used to setup the limit address of DMA protected low-memory region below 4 GB. This register must be setup before enabling protected memory through PMEN_REG, and must not be updated when protected memory regions are enabled.

This register is always treated as RO for implementations not supporting protected low memory region (PLMR field reported as 0 in the Capability register).

The alignment of the protected low memory region limit depends on the number of reserved bits (N) of this register. Software may determine the value of N by writing all 1s to this register, and finding most significant zero bit position with 0 in the value read back from the register. Bits N:0 of the limit register is decoded by hardware as all 1s.

The Protected low-memory base & limit registers functions as follows.

- Programming the protected low-memory base and limit registers with the same value in bits 31:(N+1) specifies a protected low-memory region of size $2^{(N+1)}$ bytes.
- Programming the protected low-memory limit register with a value less than the protected low-memory base register disables the protected low-memory region.

Software must not modify this register when protected memory regions are enabled. (PRS field Set in PMEN_REG).

B/D/F/Type:		0/0/0/DMIVC1REMAP	
Address Offset:		6C–6Fh	
Reset Value:		0000000h	
Access:		RW, RO	
Bit	Attr	Reset Value	Description
31:21	RW	000h	Protected Low-Memory Limit (PLML) This register specifies the last host physical address of the DMA protected low-memory region in system memory.
20:0	RO	000000h	Reserved



2.16.17 PHMBASE_REG—Protected High-Memory Base Register

This register is used to set up the base address of DMA-protected high-memory region. This register must be set up before enabling protected memory through PMEN_REG, and must not be updated when protected memory regions are enabled.

This register is always treated as RO for implementations not supporting protected high memory region (PHMR field reported as Clear in the Capability register).

The alignment of the protected high memory region base depends on the number of reserved bits (N:0) of this register. Software may determine N by writing all 1s to this register, and finding most significant zero bit position below host address width (HAW) in the value read back from the register. Bits N:0 of this register are decoded by hardware as all 0s.

Software may setup the protected high memory region either above or below 4GB.

The VTd specification describes the Protected High-Memory Limit register and hardware decoding of these registers.

Software must not modify this register when protected memory regions are enabled. (PRS field Set in PMEN_REG).

B/D/F/Type:		0/0/0/DMIVC1REMAP	
Address Offset:		70–77h	
Reset Value:		0000000000000000h	
Access:		RW, RO	
Bit	Attr	Reset Value	Description
63:21	RW	00000000 000h	Protected High-Memory Base (PHMB) This register specifies the base of protected (high) memory region in system memory. Hardware ignores, and does not implement, bits 63:HAW, where HAW is the host address width.
20:0	RO	000000h	Reserved



2.16.18 PHMLIMIT_REG—Protected High-Memory Limit Register

This register is used to setup the limit address of DMA protected high-memory region. This register must be setup before enabling protected memory through PMEN_REG, and must not be updated when protected memory regions are enabled.

This register is always treated as RO for implementations not supporting protected high memory region (PHMR field reported as 0 in the Capability register).

The alignment of the protected high memory region limit depends on the number of reserved bits (N) of this register. Software may determine the value of N by writing all 1s to this register, and finding most significant zero bit position below host address width (HAW) in the value read back from the register. Bits N:0 of the limit register is decoded by hardware as all 1s.

The protected high-memory base & limit registers functions as follows.

- Programming the protected low-memory base and limit registers with the same value in bits HAW:(N+1) specifies a protected low-memory region of size $2^{(N+1)}$ bytes.
- Programming the protected high-memory limit register with a value less than the protected high-memory base register disables the protected high-memory region.

Software must not modify this register when protected memory regions are enabled. (PRS field Set in PMEN_REG).

B/D/F/Type:		0/0/0/DMIVC1REMAP	
Address Offset:		78–7Fh	
Reset Value:		0000000000000000h	
Access:		RW, RO	
Bit	Attr	Reset Value	Description
63:21	RW	00000000000h	Protected High-Memory Limit (PHML) This register specifies the last host physical address of the DMA protected high-memory region in system memory. Hardware may not use bits 63:HAW, where HAW is the host address width.
20:0	RO	000000h	Reserved

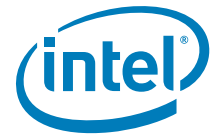

2.16.19 IQH_REG—Invalidation Queue Head Register

This register indicates the invalidation queue head. This register is treated as reserved by implementations reporting Queued Invalidation (QI) as not supported in the Extended Capability register.

B/D/F/Type:		0/0/0/DMIVC1REMAP	
Address Offset:		80–87h	
Reset Value:		0000000000000000h	
Access:		RO	
Bit	Attr	Reset Value	Description
63:19	RO	00000000 0000h	Reserved
18:4	RO	0000h	Queue Head (QH) Specifies the offset (128-bit aligned) to the invalidation queue for the command that will be fetched next by hardware. Hardware resets this field to 0 whenever the queued invalidation is disabled (QIES field Clear in the Global Status register).
3:0	RO	0h	Reserved

2.16.20 IQT_REG—Invalidation Queue Tail Register

This register indicates the invalidation tail head. This register is treated as reserved by implementations reporting Queued Invalidation (QI) as not supported in the Extended Capability register.

B/D/F/Type:		0/0/0/DMIVC1REMAP	
Address Offset:		88–8Fh	
Reset Value:		0000000000000000h	
Access:		RO	
Bit	Attr	Reset Value	Description
63:19	RO	00000000 0000h	Reserved
18:4	RO	0000h	Queue Tail (QT) Specifies the offset (128-bit aligned) to the invalidation queue for the command that will be written next by software.
3:0	RO	0h	Reserved



2.16.21 IQA_REG—Invalidation Queue Address Register

This register is used to configure the base address and size of the invalidation queue. The register is treated as reserved by implementations reporting Queued Invalidation (QI) as not supported in the Extended Capability register.

When supported, writing to this register causes the Invalidation Queue Head and Invalidation Queue Tail registers to be reset to 0h.

B/D/F/Type:		0/0/0/DMIVC1REMAP	
Address Offset:		90–97h	
Reset Value:		00000000h	
Access:		RO	
Bit	Attr	Reset Value	Description
63:12	RO	00000000 00000h	Invalidation Queue Base Address (IQA) This field points to the base of 4 KB aligned invalidation request queue. Hardware ignores and does not implement bits 63:HAW, where HAW is the host address width. Reads of this field return the value that was last programmed to it.
11:3	RO	000h	Reserved
2:0	RO	000b	Queue Size (QS) This field specifies the size of the invalidation request queue. A value of X in this field indicates an invalidation request queue of (2 ^X) 4KB pages. The number of entries in the invalidation queue is 2 ^(X + 8) .

2.16.22 ICS_REG—Invalidation Completion Status Register

This register reports completion status of invalidation wait descriptor with Interrupt Flag (IF) Set. The register is treated as reserved by implementations reporting Queued Invalidation (QI) as not supported in the Extended Capability register.

B/D/F/Type:		0/0/0/DMIVC1REMAP	
Address Offset:		9C–9Fh	
Reset Value:		00000000h	
Access:		RO	
Bit	Attr	Reset Value	Description
31:1	RO	00000000 h	Reserved
0	RO	0b	Invalidation Wait Descriptor Complete (IWC) Indicates completion of Invalidation Wait Descriptor with Interrupt Flag (IF) field Set. Hardware implementations not supporting queued invalidations implement this field as reserved.

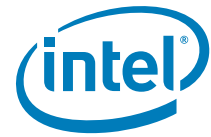

2.16.23 IECTL_REG—Invalidation Event Control Register

This register specifies the invalidation event interrupt control bits. This register is treated as reserved by implementations reporting Queued Invalidation (QI) as not supported in the Extended Capability register.

B/D/F/Type:		0/0/0/DMIVC1REMAP	
Address Offset:		A0–A3h	
Reset Value:		00000000h	
Access:		RO	
Bit	Attr	Reset Value	Description
31	RO	0b	<p>Interrupt Mask (IM)</p> <p>0 = No masking of interrupt. When a invalidation event condition is detected, hardware issues an interrupt message (using the Invalidation Event Data & Invalidation Event Address register values).</p> <p>1 = When implemented, this is the value on reset. Software may mask interrupt message generation by setting this field. Hardware is prohibited from sending the interrupt message when this field is Set.</p>
30	RO	0b	<p>Interrupt Pending (IP)</p> <p>Hardware sets the IP field whenever it detects an interrupt condition. Interrupt condition is defined as:</p> <ul style="list-style-type: none"> An Invalidation Wait Descriptor with Interrupt Flag (IF) field Set completed, setting the IWC field in the Invalidation Completion Status register. If the IWC field in the Invalidation Completion Status register was already Set at the time of setting this field, it is not treated as a new interrupt condition. <p>The IP field is kept Set by hardware while the interrupt message is held pending. The interrupt message could be held pending due to interrupt mask (IM field) being set, or due to other transient hardware conditions. The IP field is cleared by hardware as soon as the interrupt message pending condition is serviced. This could be due to either:</p> <ul style="list-style-type: none"> Hardware issuing the interrupt message due to either change in the transient hardware condition that caused interrupt message to be held pending or due to software clearing the IM field. Software servicing the IWC field in the Invalidation Completion Status register.
29:0	RO	00..00b	Reserved



2.16.24 IEDATA_REG—Invalidation Event Data Register

This register specifies the Invalidation Event interrupt message data. This register is treated as reserved by implementations reporting Queued Invalidation (QI) as not supported in the Extended Capability register.

B/D/F/Type:		0/0/0/DMIVC1REMAP	
Address Offset:		A4–A7h	
Reset Value:		00000000h	
Access:		RO	
Bit	Attr	Reset Value	Description
31:16	RO	0000h	Extended Interrupt Message Data (EIMD) This field is valid only for implementations supporting 32-bit interrupt data fields. Hardware implementations supporting only 16-bit interrupt data treat this field as reserved.
15:0	RO	0000h	Interrupt Message Data (IMD) Data value in the interrupt request. Software requirements for programming this register are described in the VTd specification.

2.16.25 IEADDR_REG—Invalidation Event Address Register

This register specifies the Invalidation Event Interrupt message address. This register is treated as reserved by implementations reporting Queued Invalidation (QI) as not supported in the Extended Capability register.

B/D/F/Type:		0/0/0/DMIVC1REMAP	
Address Offset:		A8–ABh	
Reset Value:		00000000h	
Access:		RO	
Bit	Attr	Reset Value	Description
31:2	RO	00000000h	Message Address (MA) When fault events are enabled, the contents of this register specify the DWORD-aligned address (bits 31:2) for the interrupt request. Software requirements for programming this register are described in the VTd specification Section 5.7.
1:0	RO	00b	Reserved



2.16.26 IEUADDR_REG—Invalidation Event Upper Address Register

This register specifies the Invalidation Event interrupt message upper address. This register is treated as reserved by implementations reporting both Queued Invalidation (QI) and Extended Interrupt Mode (EIM) as not supported in the Extended Capability register.

B/D/F/Type:		0/0/0/DMIVC1REMAP	
Address Offset:		AC–AFh	
Reset Value:		0000_0000h	
Access:		RO	
Bit	Attr	Reset Value	Description
31:0	RO	0000_0000h	<p>Message Upper Address (MUA) Hardware implementations supporting Queued Invalidation and Extended Interrupt Mode are required to implement this register. Software requirements for programming this register are described in the VTd specification. Hardware implementations not supporting Queued Invalidation and Extended Interrupt Mode may treat this field as reserved.</p>

2.16.27 IRTA_REG—Interrupt Remapping Table Address Register

This register provides the base address of Interrupt remapping table. The register is treated as reserved by implementations reporting Interrupt Remapping (IR) as not supported in the Extended Capability register.

B/D/F/Type:		0/0/0/DMIVC1REMAP	
Address Offset:		B8–BFh	
Reset Value:		0000000000000000h	
Access:		RO	
Bit	Attr	Reset Value	Description
63:12	RO	000000000000h	<p>Interrupt Remapping Table Address (IRTA) This field points to the base of the 4 KB aligned interrupt remapping table. Hardware ignores and not 63:HAW, where HAW is the width. Reads of this field returns last value programmed to it.</p>
11	RO	0b	<p>Extended Interrupt Mode Enable (EIMI) 0 = xAPIC mode is active. Hardware interprets only low 8-bits of Destination-ID field in the IRTEs. The high 24 bits of the Destination-ID field are treated as reserved. On the processor platforms hardware interprets low 16-bits of Destination-ID field in the IRTEs and treats the high 16-bits as reserved. 1 = x2APIC mode is active. Hardware interprets all 32-bits of the Destination-ID field in the IRTEs. Hardware reporting Extended Interrupt Mode (EIM) as Clear in the Capability register treats this field as reserved.</p>
10:4	RO	00h	Reserved
3:0	RO	0h	<p>Size (S) This field specifies the size of the interrupt remapping table. The number of entries in the interrupt remapping table is $2^{(X+1)}$, where X is the value programmed in this field.</p>



2.16.28 IVA_REG—Invalidate Address Register

This register provides the DMA address whose corresponding IOTLB entry needs to be invalidated through the corresponding IOTLB Invalidate register. The register is a write-only register. Value returned on reads of this register is undefined.

B/D/F/Type:		0/0/0/DMIVC1REMAP	
Address Offset:		100–107h	
Reset Value:		0000000000000000h	
Access:		W, RO	
Bit	Attr	Reset Value	Description
63:12	W	00000000 00000h	Address (ADDR) Software provides the DMA address that needs to be page-selectively invalidated. To request a page-selective invalidation request to hardware, software must first write the appropriate fields in this register, and then issue appropriate page-selective invalidate command through the IOTLB_REG. Hardware ignores bits 63:N, where N is the maximum guest address width (MGAW) supported. Value returned on read of this field is undefined.
11:7	RO	00h	Reserved
6	W	0b	Invalidation Hint (IH) The field provides hint to hardware to preserve or flush the non-leaf (page-directory) entries that may be cached in hardware. 0 = Software may have modified both leaf and non-leaf page-table entries corresponding to mappings specified in the ADDR and AM fields. On a page-selective invalidation request, hardware must flush both the cached leaf and non-leaf page-table entries corresponding to mappings specified by ADDR and AM fields. 1 = Software has not modified any non-leaf page-table entries corresponding to mappings specified in the ADDR and AM fields. On a page-selective invalidation request, hardware may preserve the cached non-leaf page-table entries corresponding to mappings specified by ADDR and AM fields. Value returned on read of this field is undefined.
5:0	W	00h	Address Mask (AM) The value in this field specifies the number of low order bits of the ADDR field that must be masked for the invalidation operation. Mask field enables software to request invalidation of contiguous mappings for size-aligned regions. For example: Mask Value ADDR bits masked Pages invalidated Mask Value Addr bits masked Pg inval 0 Nil 1 1 12 2 2 13:12 4 3 14:12 8 4 15:12 16 5 16:12 32 6 17:12 64 7 18:12 128 8 19:12 256 Hardware implementations report the maximum supported mask value through the Capability register. Value returned on read of this field is undefined.

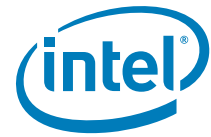

2.16.29 IOTLB_REG—IOTLB Invalidate Register

This register is used to invalidate IOTLB. The act of writing the upper byte of the IOTLB_REG with IVT field set causes the hardware to perform the IOTLB invalidation.

B/D/F/Type:		0/0/0/DMIVC1REMAP	
Address Offset:		108–10Fh	
Reset Value:		0000000000000000h	
Access:		RO, RW, RW-SC	
Bit	Attr	Reset Value	Description
63	RW-SC	0b	<p>Invalidate IOTLB (IVT)</p> <p>Software requests IOTLB invalidation by setting this field. Software must also set the requested invalidation granularity by programming the IIRG field.</p> <p>Hardware clears the IVT field to indicate the invalidation request is complete. Hardware also indicates the granularity at which the invalidation operation was performed through the IAIG field. Software must not submit another invalidation request through this register while the IVT field is set, nor update the associated Invalidate Address register.</p> <p>Software must not submit IOTLB invalidation requests when there is a context-cache invalidation request pending at this DMA-remapping hardware unit.</p> <p>Refer to the VTd specification for software programming requirements.</p> <p>Hardware implementations reporting write-buffer flushing requirement (RWBF=1 in Capability register) must implicitly perform a write buffer flush before invalidating the IOTLB.</p> <p>Refer to the VTd specification for write buffer flushing requirements.</p>
62:60	RW	000b	<p>IOTLB Invalidation Request Granularity (IIRG)</p> <p>When requesting hardware to invalidate the IOTLB (by setting the IVT field), software writes the requested invalidation granularity through this IIRG field. Following are the encodings for the IIRG field.</p> <p>000 = Reserved.</p> <p>001 = Global invalidation request.</p> <p>010 = Domain-selective invalidation request. The target domain-id must be specified in the DID field.</p> <p>011 = Domain-page-selective invalidation request. The target address, mask and invalidation hint must be specified in the Invalidate Address register, and the domain-id must be provided in the DID field.</p> <p>100 – 111 = Reserved.</p> <p>Hardware implementations may process an invalidation request by performing invalidation at a coarser granularity than requested. Hardware indicates completion of the invalidation request by clearing the IVT field. At this time, the granularity at which actual invalidation was performed is reported through the IAIG field.</p>

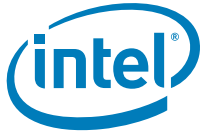

B/D/F/Type: Address Offset: Reset Value: Access:		O/O/O/DMIVC1REMAP 108–10Fh 000000000000000h RO, RW, RW-SC	
Bit	Attr	Reset Value	Description
59:57	RO	000b	<p>IOTLB Actual Invalidation Granularity (IAIG)</p> <p>Hardware reports the granularity at which an invalidation request was processed through this field at the time of reporting invalidation completion (by clearing the IVT field).</p> <p>The following are the encodings for the IAIG field.</p> <p>000 = Reserved. This indicates hardware detected an incorrect invalidation request and ignored the request. Examples of incorrect invalidation requests include detecting an unsupported address mask value in Invalidate Address register for page-selective invalidation requests.</p> <p>001 = Global Invalidation performed. This could be in response to a global, domain-selective, or page-selective invalidation request.</p> <p>010 = Domain-selective invalidation performed using the domain-id specified by software in the DID field. This could be in response to a domain-selective or page-selective invalidation request.</p> <p>011 = Domain-page-selective invalidation performed using the address, mask and hint specified by software in the Invalidate Address register and domain-id specified in DID field. This can be in response to a domain-page-selective invalidation request.</p> <p>100–111 = Reserved.</p>
56:50	RO	00h	Reserved
49	RW	0b	<p>Drain Reads (DR)</p> <p>This field is ignored by hardware if the DRD field is reported as clear in the Capability register.</p> <p>When DRD field is reported as set in the Capability register, the following encodings are supported for this field:</p> <p>0 = Hardware may complete the IOTLB invalidation without draining any translated DMA reads that are queued in the root-complex and yet to be processed.</p> <p>1 = Hardware must drain all/relevant translated DMA reads that are queued in the root-complex before indicating IOTLB invalidation completion to software.</p> <p>Refer to the VTd specification for description of DMA draining.</p>
48	RW	0b	<p>Drain Writes (DW)</p> <p>This field is ignored by hardware if the DWD field is reported as clear in the Capability register.</p> <p>When DWD field is reported as set in the Capability register, the following encodings are supported for this field:</p> <p>0 = Hardware may complete the IOTLB invalidation without draining any translated DMA writes that are queued in the root-complex for processing.</p> <p>1 = Hardware must drain all/relevant translated DMA writes that are queued in the root-complex before indicating IOTLB invalidation completion to software.</p> <p>Refer to the VTd specification for description of DMA draining.</p>
47:32	RW	0000h	<p>Domain-ID (DID)</p> <p>Indicates the ID of the domain whose IOTLB entries need to be selectively invalidated. This field must be programmed by software for domain-selective and domain-page-selective invalidation requests.</p> <p>The Capability register reports the domain-id width supported by hardware. Software must ensure that the value written to this field is within this limit. Hardware may ignore and not implement bits 47:(32+N) where N is the supported domain-id width reported in the capability register.</p>
31:0	RO	0000_0000h	Reserved



2.16.30 FRCD_REG—Fault Recording Registers

These Registers record fault information when primary fault logging is active. Hardware reports the number and location of fault recording registers through the Capability register. This register is relevant only for primary fault logging.

These registers are sticky and can be cleared only through powergood reset or using software clearing the RWC fields by writing a 1.

B/D/F/Type:		0/0/0/DMIVC1REMAP	
Address Offset:		200–20Fh	
Reset Value:		00000000000000000000000000000000h	
Access:		RW1C-S, RO-V-S, RO	
Bit	Attr	Reset Value	Description
127	RW1C-S	0b	<p>Fault (F) Hardware sets this field to indicate a fault is logged in this Fault Recording register. The F field is Set by hardware after the details of the fault is recorded in other fields. When this field is Set, hardware may collapse additional faults from the same source-id (SID). Software writes the value read from this field to Clear it. Refer to the VTd specification for hardware details of primary fault logging.</p>
126	RO-V-S	0b	<p>Type (T) Type of the faulted request: 0 = Write request 1 = Read request This field is relevant only when the F field is set, and when the fault reason (FR) indicates one of the DMA-remapping fault conditions.</p>
125:124	RO-V-S	00b	<p>Address Type (AT) This field captures the AT field from the faulted DMA request. Hardware implementations not supporting Device-IOTLBs (DI field Clear in Extended Capability register) treat this field as reserved. When supported, this field is valid only when the F field is set, and when the fault reason (FR) indicates one of the DMA-remapping fault conditions.</p>
123:104	RO	00000h	Reserved
103:96	RO-V-S	00h	<p>Fault Reason (FR) Reason for the fault. VTd specification 1.2 Appendix enumerates the various translation fault reason encodings. This field is relevant only when the F field is set.</p>
95:80	RO	0000h	Reserved
79:64	RO-V-S	0000h	<p>Source Identifier (SID) Requester-id associated with the fault condition. This field is relevant only when the F field is set.</p>
63:12	RO-V-S	00000000 00000h	<p>Fault Info (FI) When the Fault Reason (FR) field indicates one of the DMA-remapping fault conditions, bits 63:12 of this field contains the page address in the faulted DMA request. Hardware treat bits 63:N as reserved (0), where N is the maximum guest address width (MGAW) supported. When the Fault Reason (FR) field indicates one of the interrupt-remapping fault conditions, bits 63:48 of this field indicate the interrupt_index computed for the faulted interrupt request, and bits 47:12 are cleared. This field is relevant only when the F field is set.</p>
11:0	RO	000h	Reserved



2.16.31 VTPOLICY—DMA Remap Engine Policy Control

This registers contains all the policy bits related to the DMA remap engine.

B/D/F/Type:		0/0/0/DMIVC1REMAP	
Address Offset:		FFC—FFFh	
Reset Value:		0000000h	
Access:		RO, RW-L-K, RW-L	
Bit	Attr	Reset Value	Description
31	RW-L-K	0b	DMA Remap Engine Policy Lock-Down (DMAR_LCKDN) This bit protects all the DMA remap engine specific policy configuration registers. Once this bit is set by software all the DMA remap engine registers within the range 0xF00 to 0xFFC will be read-only. This bit can only be clear through platform reset.
30:5	RO	0000000h	Reserved
4	RW-L	0b	TLB Lookup Policy TLB Invalidation (LKUPPTLBINV) DMI Intel High Definition Audio Remap Engine TLB Lookup Policy On TLB Invalidation: 1 = Mask all TLB Lookup to DMI Intel High Definition Audio remap engine during TLB Invalidation Window. 0 = Continue to perform TLB lookup to DMI Intel High Definition Audio remap engine during TLB Invalidation Window. TLB Invalidation Window refers to the period from when the TLB Invalidation is initiated until all the outstanding DMA read and write cycles at the point of TLB Invalidation are initiated are Globally Ordered.
3	RW-L	0b	DMI VC1 Hit Queue Throttling (DMIVC1HTQT) 1 = Throttle the outlet DMI VC1 Hit Queue to fill up the queue. 0 = No throttling at the outlet of the DMI VC1 Hit Queue.
2	RW-L	0b	DMIVC1 TLB Disable (DMIVC1TLBDIS) 1 = DMIVC1 TLBs are disabled and each GPA request will result in a miss and a root walk will be requested from VTd Dispatcher. 0 = normal mode, DMIVC1 TLBs are enabled and normal hit/miss flows are followed.
1	RW-L	0b	Global IOTLB Invalidation Promotion (GLBIOTLBINV) This bit controls the IOTLB Invalidation behavior of the DMA remap engine. 1 = any type of IOTLB Invalidation (valid or invalid) will be promoted to Global IOTLB Invalidation. 0 = normal operation.
0	RW-L	0b	Global Context Invalidation Promotion (GLBCTXINV) This bit controls the Context Invalidation behavior of the DMA remap engine. 1 = any type of Context Invalidation (valid or invalid) will be promoted to Global Context Invalidation. 0 = normal operation.



2.17 Graphics Control Registers

2.17.1 MGGC—Graphics Control Register

All the Bits in this register are Intel TXT lockable.

B/D/F/Type: 0/2/0/PCI Address Offset: 52–53h Reset Value: 0030h Access: RO			
Bit	Attr	Reset Value	Description
15:12	RO	0h	Reserved
11:8	RO	0h	<p>GTT Graphics Memory Size (GGMS)</p> <p>This field is used to select the amount of main memory that is pre-allocated to support the Internal Graphics Translation Table. The BIOS ensures that memory is pre-allocated only when Internal graphics is enabled.</p> <p>GSM is assumed to be a contiguous physical DRAM space with DSM, and BIOS needs to allocate a contiguous memory chunk. Hardware will drive the base of GSM from DSM only using the GSM size programmed in the register.</p> <p>0h = No memory pre-allocated. GTT cycles (Memory and IO) are not claimed.</p> <p>1h = No VT mode, 1 MB of memory pre-allocated for GTT.</p> <p>3h = No VT mode, 2 MB of memory pre-allocated for GTT.</p> <p>9h = VT mode, 2 MB of memory pre-allocated for 1 MB of Global GTT and 1 MB for Shadow GTT.</p> <p>Ah = VT mode, 3 MB of memory pre-allocated for 1.5 MB of Global GTT and 1.5 MB for Shadow GTT.</p> <p>Bh = VT mode, 4 MB of memory pre-allocated for 2 MB of Global GTT and 2 MB for Shadow GTT.</p> <p>All unspecified encodings of this register field are reserved, hardware functionality is not ensured if used.</p>
7:4	RO	0011b	<p>Graphics Mode Select (GMS)</p> <p>This field is used to select the amount of main memory that is pre-allocated to support the Internal Graphics device in VGA (non-linear) and Native (linear) modes. The BIOS ensures that memory is pre-allocated only when Internal graphics is enabled.</p> <p>0h = No memory pre-allocated. Device 2 (IGD) does not claim VGA cycles (Memory and IO), and the Sub-Class Code field within Device 2 function 0 Class Code register is 80h.</p> <p>1h = DVMT (UMA) mode, 1 MB of memory pre-allocated for frame buffer.</p> <p>2h = DVMT (UMA) mode, 4 MB of memory pre-allocated for frame buffer.</p> <p>3h = DVMT (UMA) mode, 8 MB of memory pre-allocated for frame buffer.</p> <p>4h = DVMT (UMA) mode, 16 MB of memory pre-allocated for frame buffer.</p> <p>5h = DVMT (UMA) mode, 32 MB of memory pre-allocated for frame buffer.</p> <p>6h = DVMT (UMA) mode, 48 MB of memory pre-allocated for frame buffer.</p> <p>7h = DVMT (UMA) mode, 64 MB of memory pre-allocated for frame buffer.</p> <p>8h = DVMT (UMA) mode, 128 MB of memory pre-allocated for frame buffer.</p> <p>9h = DVMT (UMA) mode, 256 MB of memory pre-allocated for frame buffer.</p> <p>BIOS Requirement: BIOS must not set this field to 000 if IVD (bit 1 of this register) is 0.</p>
3:2	RO	00b	Reserved



B/D/F/Type:		0/2/0/PCI	
Address Offset:		52–53h	
Reset Value:		0030h	
Access:		RO	
Bit	Attr	Reset Value	Description
1	RO	0b	IGD VGA Disable (IVD) 0 = Enable. Device 2 (IGD) claims VGA memory and IO cycles, the Sub-Class Code within Device 2 Class Code register is 00. 1 = Disable. Device 2 (IGD) does not claim VGA cycles (Memory and IO), and the Sub- Class Code field within Device 2 function 0 Class Code register is 80. BIOS Requirement: BIOS must not set this bit to 0 if the GMS field (bits 6:4 of this register) pre-allocates no memory. This bit MUST be set to 1 if Device 2 is disabled either using a fuse or fuse override (CAPIDO[38] = 1) or using a register (DEVEN[3] = 0).
0	RO	0b	Reserved

2.17.2 GFXPLL1—GFX PLL BIOS

This is the GFX PLL BIOS register. See latest BIOS specification for more details.

B/D/F/Type:		0/0/0/MCHBAR	
Address Offset:		2C32–2C33h	
Reset Value:		0434h	
Access:		RO, RW	
Bit	Attr	Reset Value	Description
15:11	RO	00b	Reserved
10:8	RW	100b	Core Sampler Clock Pre-Div (CSPRE) The CS pre-divider encoding is 000 = 2 001 = 2 010 = 2 011 = 3 100 = 4 101 = 5 110 = 6 111 = 6
7:6	RO	00b	Reserved
5:4	RW	10b	Core Render/Sampler Clock Post-Div (GFXPOST) Select CR/CS clocks output sel1 sel0 CRpostdiv 0 0 div1 0 1 div2 1 0 div4 1 1 div8
3	RO	0b	Reserved
2:0	RW	101b	Core Render Clock Pre-Div (CRPRE) The CR pre-divider encoding is: 000 = 2 001 = 2 010 = 2 011 = 3 100 = 4 101 = 5 110 = 6 111 = 6

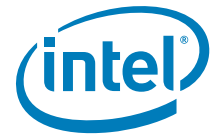

2.18 GFXVTBAR Registers

Table 2-13. GFXVTBAR Register Address Map

Address Offset	Register Symbol	Register Name	Reset Value	Access
0–3h	VER_REG	Version Register	00000010h	RO
8–Fh	CAP_REG	Capability Register	00C0000020230272h	RO
10–17h	ECAP_REG	Extended Capability Register	00000000000001000h	RO
18–1Bh	GCMD_REG	Global Command Register	00000000h	W, RO, RW
1C–1Fh	GSTS_REG	Global Status Register	00000000h	RO
20–27h	RTADDR_REG	Root-Entry Table Address Register	0000000000000000h	RO, RW
28–2Fh	CCMD_REG	Context Command Register	0800000000000000h	RW, RO
34–37h	FSTS_REG	Fault Status Register	00000000h	RO, RW1C-S, RO-V-S
38–3Bh	FECTL_REG	Fault Event Control Register	80000000h	RO, RW
3C–3Fh	FEDATA_REG	Fault Event Data Register	00000000h	RO, RW
40–43h	FEADDR_REG	Fault Event Address Register	00000000h	RW, RO
44–47h	FEUADDR_REG	Fault Event Upper Address Register	00000000h	RO
58–5Fh	AFLOG_REG	Advanced Fault Log Register	0000000000000000h	RO
64–67h	PMEN_REG	Protected Memory Enable Register	00000000h	RW, RO
68–6Bh	PLMBASE_REG	Protected Low Memory Base Register	00000000h	RO, RW
6C–6Fh	PLMLIMIT_REG	Protected Low Memory Limit Register	00000000h	RW, RO
70–77h	PHMBASE_REG	Protected High Memory Base Register	0000000000000000h	RO, RW
78–7Fh	PHMLIMIT_REG	Protected High Memory Limit Register	0000000000000000h	RO, RW
80–87h	IQH_REG	Invalidation Queue Head	0000000000000000h	RO
88–8Fh	IQT_REG	Invalidation Queue Tail	0000000000000000h	RO
90–97h	IQA_REG	Invalidation Queue Address	0000000000000000h	RO
9C–9Fh	ICS_REG	Invalidation Completion Status	00000000h	RO
A0–A3h	IECTL_REG	Invalidation Completion Event Control	80000000h	RO
A4–A7h	IEDATA_REG	Invalidation Completion Event Data	00000000h	RO
AC–AFh	IEUADDR_REG	Invalidation Completion Event Upper Address	00000000h	RO
B8–BFh	IRTA_REG	Interrupt Remapping Table Address	0000000000000000h	RO
100–107h	IVA_REG	Invalidate Address Register	0000000000000000h	RO
108–10Fh	IOTLB_REG	IOTLB Invalidate Register	0200000000000000h	RW, RO
200–20Fh	FRCD_REG	Fault Recording Registers	00000000000000000000000000000000h	RO-V-S, RO, RW1C-S
FFC–FFFh	VTPOLICY	VT Policy	40000000h	RW-L, RW-O, RO



2.18.1 VER_REG—Version Register

This register reports the architecture version supported. Backward compatibility for the architecture is maintained with new revision numbers, allowing software to load DMA-remapping drivers written for prior architecture versions.

B/D/F/Type:		0/2/0/GFXVTBAR	
Address Offset:		0–3h	
Reset Value:		00000010h	
Access:		RO	
Bit	Attr	Reset Value	Description
31:8	RO	000000h	Reserved
7:4	RO	1h	Major Version number (MAX) Indicates supported architecture version.
3:0	RO	0h	Minor Version number (MIN) Indicates supported architecture minor version.

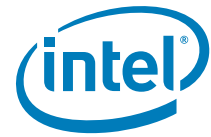

2.18.2 CAP_REG—Capability Register

This register reports general DMA remapping hardware capabilities.

B/D/F/Type:		0/2/0/GFXVTBAR	
Address Offset:		8–Fh	
Reset Value:		00C0000020230272h	
Access:		RO	
Bit	Attr	Reset Value	Description
63:56	RO	00h	Reserved
55	RO	1b	DMA Read Draining (DRD) 0 = On IOTLB invalidations, hardware does not support draining of translated DMA read requests queued within the root complex. 1 = On IOTLB invalidations, hardware supports draining of translated DMA read requests queued within the root complex. Indicates supported architecture version.
54	RO	1b	DMA Write Draining (DWD) 0 = On IOTLB invalidations, hardware does not support draining of translated DMA writes queued within the root complex. 1 = IOTLB invalidations, hardware supports draining of translated DMA writes queued within the root complex.
53:48	RO	00h	Maximum Address Mask Value (MAMV) The value in this field indicates the maximum supported value for the Address Mask (AM) field in the Invalidation Address (IVA_REG) register.
47:40	RO	00h	Number of Fault Recording Registers (NFR) Number of fault recording registers is computed as N+1, where N is the value reported in this field. Implementations must support at least one fault recording register (NFR = 0) for each DMA remapping hardware unit in the platform. The maximum number of fault recording registers per DMA-remapping hardware unit is 256.
39	RO	0b	Page-Selective Invalidation Support (PSI) 0 = Hardware supports only domain and global invalidates for IOTLB. 1 = Hardware supports page selective, domain, and global invalidates for IOTLB and hardware must support a minimum MAMV value of 9.
38	RO	0b	Reserved
37:34	RO	0h	Super-Page support (SPS) This field indicates the super page sizes supported by hardware. A value of 1 in any of these bits indicates the corresponding super-page size is supported. The super-page sizes corresponding to various bit positions within this field are: 0h = 21-bit offset to page frame (2 MB) 1h = 30-bit offset to page frame (1 GB) 2h = 39-bit offset to page frame (512 GB) 3h = 48-bit offset to page frame (1 TB)
33:24	RO	020h	Fault-recording Register offset (FRO) This field specifies the location to the first fault recording register relative to the register base address of this DMA-remapping hardware unit. If the register base address is X, and the value reported in this field is Y, the address for the first fault recording register is calculated as X+(16*Y).

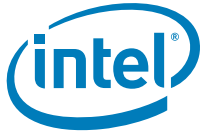

B/D/F/Type: Address Offset: Reset Value: Access:		0/2/0/GFXVTBAR 8–Fh 00C0000020230272h RO	
Bit	Attr	Reset Value	Description
23	RO	0b	<p>Isochrony (ISOCH)</p> <p>0 = Indicates this DMA-remapping hardware unit has no critical isochronous requesters in its scope.</p> <p>1 = Indicates this DMA-remapping hardware unit has one or more critical isochronous requesters in its scope. To ensure isochronous performance, software must ensure invalidation operations do not impact active DMA streams from such requesters. This implies that when DMA is active, software perform page-selective invalidations (instead of coarser invalidations).</p>
22	RO	0b	<p>Zero Length Read (ZLR)</p> <p>0 = Indicates the remapping hardware unit blocks (and treats as fault) zero length DMA read requests to write-only pages.</p> <p>1 = Indicates the remapping hardware unit supports zero length DMA read requests to write-only pages.</p>
21:16	RO	23h	<p>Maximum Guest Address Width (MGAW)</p> <p>This field indicates the maximum DMA virtual addressability supported by remapping hardware.</p> <p>The Maximum Guest Address Width (MGAW) is computed as $(N+1)$, where N is the value reported in this field. For example, a hardware implementation supporting 48-bit MGAW reports a value of 47 (101111b) in this field.</p> <p>If the value in this field is X, untranslated and translated DMA requests to addresses above $2^{(X+1)} - 1$ are always blocked by hardware. Translation requests to address above $2^{(X+1)} - 1$ from allowed devices return a null Translation Completion Data Entry with R=W=0.</p> <p>Guest addressability for a given DMA request is limited to the minimum of the value reported through this field and the adjusted guest address width of the corresponding page-table structure. (Adjusted guest address widths supported by hardware are reported through the SAGAW field).</p>
15:13	RO	000b	Reserved
12:8	RO	02h	<p>Supported adjusted guest address width (SAGAW)</p> <p>This 5-bit field indicates the supported adjusted guest address widths (which in turn represents the levels of page-table walks for the 4KB base page size) supported by the hardware implementation.</p> <p>A value of 1 in any of these bits indicates the corresponding adjusted guest address width is supported. The adjusted guest address widths corresponding to various bit positions within this field are:</p> <p>0h = 30-bit AGAW (2-level page-table) 1h = 39-bit AGAW (3-level page-table) 2h = 48-bit AGAW (4-level page-table) 3h = 57-bit AGAW (5-level page-table) 4h = 64-bit AGAW (6-level page-table)</p> <p>Software must ensure that the adjusted guest address width used to set up the page tables is one of the supported guest address widths reported in this field.</p>
7	RO	0b	<p>Caching Mode (CM)</p> <p>0 = Not-present and erroneous entries are not cached in any of the remapping caches. Invalidation are not required for modifications to individual not present or invalid entries. However, any modifications that result in decreasing the effective permissions or partial permission increases require invalidations for them to be effective.</p> <p>1 = Not-present and erroneous mappings may be cached in the remapping caches. Any software updates to the remapping structures (including updates to “notpresent” or erroneous entries) require explicit invalidation.</p> <p>Hardware implementations of this architecture must support a value of 0 in this field. Refer to the VtD specification for more details on Caching Mode.</p>

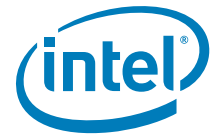

B/D/F/Type: Address Offset: Reset Value: Access:		0/2/0/GFXVTBAR 8–Fh 00C0000020230272h RO	
Bit	Attr	Reset Value	Description
6	RO	1b	Protected High-Memory Region (PHMR) 0 = Indicates protected high-memory region is not supported. 1 = Indicates protected high-memory region is supported. DMA-remapping hardware implementations on Intel TXT platforms supporting main memory above 4 GB are required to support protected high-memory region.
5	RO	1b	Protected Low-Memory Region (PLMR) 0 = Indicates protected low-memory region is not supported. 1 = Indicates protected low-memory region is supported. DMA-remapping hardware implementations on Intel TXT platforms are required to support protected low-memory region.
4	RO	1b	Required Write-Buffer Flushing (RWBF) 0 = Indicates no write-buffer flushing is needed to ensure changes to memory-resident structures are visible to hardware. 1 = Indicates software must explicitly flush the write buffers to ensure updates made to memory-resident remapping structures are visible to hardware. Refer to the VTd specification for more details on write buffer flushing requirements.
3	RO	0b	Advanced Fault Logging (AFL) 0 = Indicates advanced fault logging is not supported. Only primary fault logging is supported. 1 = Indicates advanced fault logging is supported.
2:0	RO	00b	Number of domains supported (ND) 000b = 4-bit domain-IDs with support for up to 16 domains. 001b = 6-bit domain-IDs with support for up to 64 domains. 010b = 8-bit domain-IDs with support for up to 256 domains. 011b = 10-bit domain-IDs with support for up to 1024 domains. 100b = 12-bit domain-IDs with support for up to 4K domains. 100b = 14-bit domain-IDs with support for up to 16K domains. 110b = 16-bit domain-IDs with support for up to 64K domains. 111b = Reserved.



2.18.3 ECAP_REG—Extended Capability Register

This register reports DMA-remapping hardware extended capabilities.

B/D/F/Type:		0/2/0/GFXVTBAR	
Address Offset:		10–17h	
Reset Value:		000000000001000h	
Access:		RO	
Bit	Attr	Reset Value	Description
63:24	RO	0h	Reserved
23:20	RO	0h	Maximum Handle Mask Value (MHMV) The value in this field indicates the maximum supported value for the Handle Mask (HM) field in the interrupt entry cache invalidation descriptor (iec_inv_dsc). This field is valid only when the IR field is reported as Set.
19:18	RO	00b	Reserved
17:8	RO	010h	Invalidation Unit Offset (IVO) This field specifies the offset to the IOTLB invalidation register relative to the register base address of this remapping hardware unit. If the register base address is X, and the value reported in this field is Y, the address for the IOTLB invalidation register is calculated as X+(16*Y).
7	RO	0b	Snoop Control (SC) 0 = Hardware does not support setting the SNP field to 1 in the page-table entries. 1 = Hardware supports setting the SNP field to 1 in the page-table entries.
6	RO	0b	Pass Through (PT) 0 = Hardware does not support pass through translation type in context entries. 1 = Hardware supports pass-through translation type in context entries.
5	RO	0b	Caching Hints (CH) 0 = Hardware does not support IOTLB caching hints (ALH and EH fields in context-entries are treated as reserved). 1 = Hardware supports IOLTB caching hints through the ALH and EH fields in context-entries.
4	RO	0b	Extended Interrupt Mode (EIM) 0 = Hardware supports only 8-bit APICIDs (Legacy Interrupt Mode) on Intel 64 and IA-32 platforms and 16-bit APIC-IDs on the processor platforms. 1 = Hardware supports Extended Interrupt Mode (32-bit APIC-IDs) on Intel 64 platforms. This field is valid only when the IR field is reported as Set.
3	RO	0b	Interrupt Remapping (IR) 0 = Hardware does not support interrupt remapping. 1 = Hardware supports interrupt remapping. Implementations reporting this field as Set must also support Queued Invalidation (QI = 1b).
2	RO	0b	Device IOTLB Support (DI) 0 = Hardware does not support device-IOTLBs. 1 = Hardware supports Device-IOTLBs. Implementations reporting this field as Set must also support Queued Invalidation (QI = 1b).
1	RO	0b	Queued Invalidation (QI) 0 = Hardware does not support queued invalidations. 1 = Hardware supports queued invalidations.



B/D/F/Type: 0/2/0/GFXVTBAR Address Offset: 10–17h Reset Value: 000000000001000h Access: RO			
Bit	Attr	Reset Value	Description
0	RO	0b	Coherency (C) This field indicates if hardware access to the root, context, page-table and interrupt-remap structures are coherent (snooped) or not. 0 = Indicates hardware accesses to remapping structures are noncoherent. 1 = Indicates hardware accesses to remapping structures are coherent. Hardware access to advanced fault log and invalidation queue are always coherent.

2.18.4 GCMD_REG—Global Command Register

This register to controls remapping hardware. If multiple control fields in this register need to be modified, software must serialize the modifications through multiple writes to this register.

B/D/F/Type: 0/2/0/GFXVTBAR Address Offset: 18–1Bh Reset Value: 00000000h Access: W, RO, RW			
Bit	Attr	Reset Value	Description
31	RW	0b	Translation Enable (TE) Software writes to this field to request hardware to enable/disable DMA-remapping hardware. 0 = Disable DMA-remapping hardware 1 = Enable DMA-remapping hardware Hardware reports the status of the translation enable operation through the TES field in the Global Status register. Before enabling (or re-enabling) DMA-remapping hardware through this field, software must: <ul style="list-style-type: none"> • Setup the DMA-remapping structures in memory • Flush the write buffers (through WBF field), if write buffer flushing is reported as required. • Set the root-entry table pointer in hardware (through SRTP field). • Perform global invalidation of the context-cache and global invalidation of IOTLB • If advanced fault logging supported, setup fault log pointer (through SFL field) and enable advanced fault logging (through EAFL field). Refer to the VTd specification for detailed software requirements. There may be active DMA requests in the platform when software updates this field. Hardware must enable or disable remapping logic only at deterministic transaction boundaries, so that any in-flight transaction is either subject to remapping or not at all. Hardware implementations supporting DMA draining must drain any in-flight translated DMA read/write requests queued within the root complex before completing the translation enable command and reflecting the status of the command through the TES field in the GSTS_REG. Value returned on read of this field is undefined.

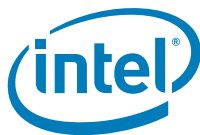

B/D/F/Type: Address Offset: Reset Value: Access:		0/2/0/GFXVTBAR 18–1Bh 00000000h W, RO, RW	
Bit	Attr	Reset Value	Description
30	W	0b	<p>Set Root Table Pointer (SRTP) Software sets this field to set/update the root-entry table pointer used by hardware. The root-entry table pointer is specified through the Root-entry Table Address register. Hardware reports the status of the “root table pointer set” operation through the RTPS field in the Global Status register. The root table pointer set operation must be performed before enabling or re-enabling (after disabling) DMA remapping through the TE field. After a “root table pointer set” operation, software must globally invalidate the context cache and then globally invalidate the IOTLB. This is required to ensure hardware uses only the remapping structures referenced by the new root table pointer, and not any stale cached entries. While DMA remapping is active, software may update the root table pointer through this field. However, to ensure valid in-flight DMA requests are deterministically remapped, software must ensure that the structures referenced by the new root table pointer are programmed to provide the same remapping results as the structures referenced by the previous root-table pointer. Clearing this bit has no effect. The value returned on a read of this field is undefined.</p>
29	RO	0b	<p>Set Fault Log (SFL) This field is valid only for implementations supporting advanced fault logging. Software sets this field to request hardware to set/update the fault-log pointer used by hardware. The fault-log pointer is specified through Advanced Fault Log register. Hardware reports the status of the fault log set operation through the FLS field in the Global Status register. The fault log pointer must be set before enabling advanced fault logging (through EAFL field). Once advanced fault logging is enabled, the fault log pointer may be updated through this field while DMA remapping is active. Clearing this bit has no effect. The value returned on read of this field is undefined.</p>
28	RO	0b	<p>Enable Advanced Fault Logging (EAFL) This field is valid only for implementations supporting advanced fault logging. Software writes to this field to request hardware to enable or disable advanced fault logging. 0 = Disable advanced fault logging. In this case, translation faults are reported through the Fault Recording registers. 1 = Enable use of memory-resident fault log. When enabled, translation faults are recorded in the memory-resident log. The fault log pointer must be set in hardware (through SFL field) before enabling advanced fault logging. Hardware reports the status of the advanced fault logging enable operation through the AFLS field in the Global Status register. Value returned on read of this field is undefined.</p>
27	W	0b	<p>Write Buffer Flush (WBF) This bit is valid only for implementations requiring write buffer flushing. Software sets this field to request hardware to flush the root-complex internal write buffers. This is done to ensure any updates to the memory-resident remapping structures are not held in any internal write posting buffers. Refer to the VTd specification for details on write-buffer flushing requirements. Hardware reports the status of the write buffer flushing operation through the WBFS field in the Global Status register. Clearing this bit has no effect. Value returned on read of this field is undefined.</p>

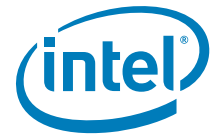

B/D/F/Type: Address Offset: Reset Value: Access:		0/2/0/GFXVTBAR 18–1Bh 00000000h W, RO, RW	
Bit	Attr	Reset Value	Description
26	RO	0b	<p>Queued Invalidation Enable (QIE)</p> <p>This field is valid only for implementations supporting queued invalidations. Software writes to this field to enable or disable queued invalidations.</p> <p>0 = Disable queued invalidations. 1 = Enable use of queued invalidations.</p> <p>Hardware reports the status of queued invalidation enable operation through QIES field in the Global Status register.</p> <p>Refer to the VTd specification for software requirements for enabling/disabling queued invalidations.</p> <p>The value returned on a read of this field is undefined.</p>
25	RO	0b	<p>Interrupt Remapping Enable (IRE)</p> <p>This field is valid only for implementations supporting interrupt remapping.</p> <p>0 = Disable interrupt-remapping hardware 1 = Enable interrupt-remapping hardware</p> <p>Hardware reports the status of the interrupt remapping enable operation through the IRES field in the Global Status register.</p> <p>There may be active interrupt requests in the platform when software updates this field. Hardware must enable or disable interrupt-remapping logic only at deterministic transaction boundaries, so that any in-flight interrupts are either subject to remapping or not at all.</p> <p>Hardware implementations must drain any in-flight interrupts requests queued in the Root-Complex before completing the interrupt-remapping enable command and reflecting the status of the command through the IRES field in the Global Status register.</p> <p>The value returned on a read of this field is undefined.</p>
24	RO	0b	<p>Set Interrupt Remap Table Pointer (SIRTP)</p> <p>This field is valid only for implementations supporting interrupt-remapping. Software sets this field to set/update the interrupt remapping table pointer used by hardware. The interrupt remapping table pointer is specified through the Interrupt Remapping Table Address register.</p> <p>Hardware reports the status of the interrupt remapping table pointer set operation through the IRTPS field in the Global Status register.</p> <p>The interrupt remap table pointer set operation must be performed before enabling or re-enabling (after disabling) interrupt-remapping hardware through the IRE field.</p> <p>After an interrupt remap table pointer set operation, software must globally invalidate the interrupt entry cache. This is required to ensure hardware uses only the interrupt-remapping entries referenced by the new interrupt remap table pointer, and not any stale cached entries.</p> <p>While interrupt remapping is active, software may update the interrupt remapping table pointer through this field. However, to ensure valid in-flight interrupt requests are deterministically remapped, software must ensure that the structures referenced by the new interrupt remap table pointer are programmed to provide the same remapping results as the structures referenced by the previous interrupt remap table pointer.</p> <p>Clearing this bit has no effect. The value returned on a read of this field is undefined.</p>



B/D/F/Type:		0/2/0/GFXVTBAR	
Address Offset:		18–1Bh	
Reset Value:		00000000h	
Access:		W, RO, RW	
Bit	Attr	Reset Value	Description
23	RO	0b	<p>Compatibility Format Interrupt (CFI)</p> <p>This field is valid only for Intel 64 implementations supporting interrupt-remapping.</p> <p>Software writes to this field to enable or disable Compatibility Format interrupts on Intel 64 platforms. The value in this field is effective only when interrupt-remapping is enabled and Legacy Interrupt Mode is active.</p> <p>0 = Block Compatibility format interrupts. 1 = Process Compatibility format interrupts as pass-through (bypass interrupt remapping).</p> <p>Hardware reports the status of updating this field through the CFIS field in the Global Status register.</p> <p>Refer to the VTd specification for details on Compatibility Format interrupt requests.</p> <p>The value returned on a read of this field is undefined.</p> <p>This field is not implemented.</p>
22:0	RO	000000h	Reserved

2.18.5 GSTS_REG—Global Status Register

This register reports general remapping hardware status.

B/D/F/Type:		0/2/0/GFXVTBAR	
Address Offset:		1C–1Fh	
Reset Value:		00000000h	
Access:		RO	
Bit	Attr	Reset Value	Description
31	RO	0b	<p>Translation Enable Status (TES)</p> <p>This field indicates the status of DMA-remapping hardware.</p> <p>0 = DMA-remapping hardware is not enabled 1 = DMA-remapping hardware is enabled</p>
30	RO	0b	<p>Root Table Pointer Status (RTPS)</p> <p>This field indicates the status of the root-table pointer in hardware.</p> <p>This field is cleared by hardware when software sets the SRTP field in the Global Command register. This field is set by hardware when hardware completes the set root-table pointer operation using the value provided in the Root-Entry Table Address register.</p>
29	RO	0b	<p>Fault Log Status (FLS)</p> <p>This field:</p> <ul style="list-style-type: none"> Is cleared by hardware when software Sets the SFL field in the Global Command register. Is Set by hardware when hardware completes the set fault-log pointer operation using the value provided in the Advanced Fault Log register.
28	RO	0b	<p>Advanced Fault Logging Status (AFLS)</p> <p>This field is valid only for implementations supporting advanced fault logging. It indicates the advanced fault logging status:</p> <p>0 = Advanced Fault Logging is not enabled 1 = Advanced Fault Logging is enabled</p>

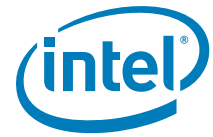

B/D/F/Type: 0/2/0/GFXVTBAR Address Offset: 1C–1Fh Reset Value: 0000000h Access: RO			
Bit	Attr	Reset Value	Description
27	RO	0b	Write Buffer Flush Status (WBFS) This field is valid only for implementations requiring write buffer flushing. This field indicates the status of the write buffer flush command. It is Set by hardware when software sets the WBF field in the Global Command register. Cleared by hardware when hardware completes the write buffer flushing operation.
26	RO	0b	Queued Invalidation Enable Status (QIES) This field indicates queued invalidation enable status. 0 = Queued invalidation is not enabled 1 = Queued invalidation is enabled
25	RO	0b	Interrupt Remapping Enable Status (IRES) This field indicates the status of Interrupt-remapping hardware. 0 = Interrupt-remapping hardware is not enabled 1 = Interrupt-remapping hardware is enabled
24	RO	0b	Interrupt Remapping Table Pointer Status (IRTPS) This field indicates the status of the interrupt remapping table pointer in hardware. This field is cleared by hardware when software sets the SIRTTP field in the Global Command register. This field is set by hardware when hardware completes the set interrupt remap table pointer operation using the value provided in the Interrupt Remapping Table Address register.
23	RO	0b	Compatibility Format Interrupt Status (CIFS) This field indicates the status of Compatibility format interrupts on Intel 64 implementations supporting interrupt-remapping. The value reported in this field is applicable only when interrupt-remapping is enabled and Legacy interrupt mode is active. 0 = Compatibility format interrupts are blocked. 1 = Compatibility format interrupts are processed as pass-through (bypassing interrupt remapping).
22:0	RO	000000h	Reserved



2.18.6 RTADDR_REG—Root-Entry Table Address Register

This register provides the base address of root-entry table.

B/D/F/Type:		0/2/0/GFXVTBAR	
Address Offset:		20–27h	
Reset Value:		0000000000000000h	
Access:		RO, RW	
Bit	Attr	Reset Value	Description
63:36	RO	0000000h	Reserved
35:12	RW	000000h	<p>Root table address (RTA) This register points to base of page aligned, 4 KB-sized root-entry table in system memory. Hardware may ignore and not implement bits 63:HAW, where HAW is the host address width. Software specifies the base address of the root-entry table through this register, and programs it in hardware through the SRTP field in the Global Command register. Reads of this register return the value that was last programmed to it.</p>
11:0	RO	000h	Reserved

2.18.7 CCMD_REG—Context Command Register

This register manages context cache. The act of writing the uppermost byte of the CCMD_REG with the ICC field set causes the hardware to perform the context-cache invalidation.

B/D/F/Type:		0/2/0/GFXVTBAR	
Address Offset:		28–2Fh	
Reset Value:		0800000000000000h	
Access:		RW, RO	
Bit	Attr	Reset Value	Description
63	RW	0b	<p>Invalidate Context Cache (ICC) Software requests invalidation of context-cache by setting this field. Software must also set the requested invalidation granularity by programming the CIRG field. Software must read back and check the ICC field is Clear to confirm the invalidation is complete. Software must not update this register when this field is Set. Hardware clears the ICC field to indicate the invalidation request is complete. Hardware also indicates the granularity at which the invalidation operation was performed through the CAIG field. Software must submit a context-cache invalidation request through this field only when there are no invalidation requests pending at this remapping hardware unit. Refer to the VTd specification for software programming requirements. Since information from the context-cache may be used by hardware to tag IOTLB entries, software must perform domain-selective (or global) invalidation of IOTLB after the context cache invalidation has completed. Hardware implementations reporting a write-buffer flushing requirement (RWBF=1 in the Capability register) must implicitly perform a write buffer flush before invalidating the context-cache. Refer to the VTd specification for write buffer flushing requirements.</p>

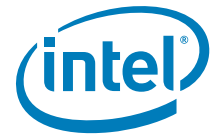

B/D/F/Type: Address Offset: Reset Value: Access:		0/2/0/GFXVTBAR 28–2Fh 0800000000000000h RW, RO	
Bit	Attr	Reset Value	Description
62:61	RW	00b	<p>Context Invalidation Request Granularity (CIRG)</p> <p>Software provides the requested invalidation granularity through this field when setting the ICC field:</p> <p>00 = Reserved.</p> <p>01 = Global Invalidation request.</p> <p>10 = Domain-selective invalidation request. The target domain-id must be specified in the DID field.</p> <p>11 = Device-selective invalidation request. The target source-id(s) must be specified through the SID and FM fields, and the domain-id [that was programmed in the context-entry for these device(s)] must be provided in the DID field.</p> <p>Hardware implementations may process an invalidation request by performing invalidation at a coarser granularity than requested. Hardware indicates completion of the invalidation request by clearing the ICC field. At this time, hardware also indicates the granularity at which the actual invalidation was performed through the CAIG field.</p>
60:59	RO	01b	<p>Context Actual Invalidation Granularity (CAIG)</p> <p>Hardware reports the granularity at which an invalidation request was processed through the CAIG field at the time of reporting invalidation completion (by clearing the ICC field).</p> <p>The following are the encodings for this field:</p> <p>00 = Reserved.</p> <p>01 = Global Invalidation performed. This could be in response to a global, domain-selective, or device-selective invalidation request.</p> <p>10 = Domain-selective invalidation performed using the domain-id specified by software in the DID field. This could be in response to a domain-selective or device-selective invalidation request.</p> <p>11 = Device-selective invalidation performed using the source-id and domain-id specified by software in the SID and FM fields. This can only be in response to a device-selective invalidation request.</p>
58:34	RO	0000000h	Reserved
33:32	RO	00b	<p>Function Mask (FM)</p> <p>This field specifies which bits of the function number portion (least significant three bits) of the SID field to mask when performing device-selective invalidations.</p> <p>The following encodings are defined for this field:</p> <p>00 =No bits in the SID field masked.</p> <p>01 =Mask most significant bit of function number in the SID field.</p> <p>10 =Mask two most significant bit of function number in the SID field.</p> <p>11 =Mask all three bits of function number in the SID field.</p> <p>The device(s) specified through the FM and SID fields must correspond to the domain-ID specified in the DID field.</p> <p>Value returned on read of this field is undefined.</p>
31:16	RO	0000h	<p>Source-ID (SID)</p> <p>This field indicates the source-id of the device whose corresponding context-entry needs to be selectively invalidated. This field along with the FM field must be programmed by software for device-selective invalidation requests.</p> <p>Value returned on read of this field is undefined.</p>
15:0	RW	0000h	<p>Domain-ID (DID)</p> <p>This field indicates the ID of the domain whose context-entries need to be selectively invalidated. This field must be programmed by software for both domain-selective and device-selective invalidation requests.</p> <p>The Capability register reports the domain-id width supported by hardware. Software must ensure that the value written to this field is within this limit.</p> <p>Hardware ignores (and may not implement) bits 15:N where N is the supported domain-id width reported in the capability register.</p>



2.18.8 FSTS_REG—Fault Status Register

This register indicates the various error statuses.

B/D/F/Type:		0/2/0/GFXVTBAR	
Address Offset:		34–37h	
Reset Value:		0000000h	
Access:		RO, RW1C-S, RO-V-S	
Bit	Attr	Reset Value	Description
31:16	RO	0000h	Reserved
15:8	RO-V-S	00h	<p>Fault Record Index (FRI)</p> <p>This field is valid only when the PPF field is Set.</p> <p>The FRI field indicates the index (from base) of the fault recording register to which the first pending fault was recorded when the PPF field was Set by hardware.</p> <p>The value read from this field is undefined when the PPF field is Clear.</p>
7	RO	0b	Reserved
6	RO	0b	<p>Invalidation Time-out Error (ITE)</p> <p>Hardware detected a Device-IOTLB invalidation completion time-out. At this time, a fault event may be generated based on the programming of the Fault Event Control register.</p> <p>Hardware implementations not supporting Device-IOTLBs implement this bit as reserved.</p>
5	RO	0b	<p>Invalidation Completion Error (ICE)</p> <p>Hardware received an unexpected or invalid Device-IOTLB invalidation completion. This could be due to either an invalid ITag or invalid source-id in an invalidation completion response. At this time, a fault event may be generated based on the programming of the Fault Event Control register.</p> <p>Hardware implementations not supporting Device-IOTLBs implement this bit as reserved.</p>
4	RO	0b	<p>Invalidation Queue Error (IQE)</p> <p>Hardware detected an error associated with the invalidation queue. This could be due to either a hardware error while fetching a descriptor from the invalidation queue, or hardware detecting an erroneous or invalid descriptor in the invalidation queue. At this time, a fault event may be generated based on the programming of the Fault Event Control register.</p> <p>Hardware implementations not supporting queued invalidations implement this bit as reserved.</p>
3	RO	0b	<p>Advanced Pending Fault (APF)</p> <p>When this field is Clear, hardware sets this field when the first fault record (at index 0) is written to a fault log. At this time, a fault event is generated based on the programming of the Fault Event Control register.</p> <p>Software writing 1 to this field clears it. Hardware implementations not supporting advanced fault logging implement this bit as reserved.</p>
2	RO	0b	<p>Advanced Fault Overflow (AFO)</p> <p>Hardware sets this field to indicate advanced fault log overflow condition. At this time, a fault event is generated based on the programming of the Fault Event Control register.</p> <p>Software writing 1 to this field clears it. Hardware implementations not supporting advanced fault logging implement this bit as reserved.</p>



B/D/F/Type: 0/2/0/GFXVTBAR Address Offset: 34–37h Reset Value: 00000000h Access: RO, RW1C-S, RO-V-S			
Bit	Attr	Reset Value	Description
1	RO-V-S	0b	Primary Pending Fault (PPF) This field indicates if there are one or more pending faults logged in the fault recording registers. Hardware computes this field as the logical OR of Fault (F) fields across all the fault recording registers of this remapping hardware unit. 0 = No pending faults in any of the fault recording registers 1 = One or more fault recording registers has pending faults. The FRI field is updated by hardware whenever the PPF field is Set by hardware. Also, depending on the programming of Fault Event Control register, a fault event is generated when hardware sets this field.
0	RW1C-S	0b	Primary Fault Overflow (PFO) Hardware sets this field to indicate overflow of the fault recording registers. Software writing 1 clears this field. When this field is Set, hardware does not record any new faults until software clears this field.



2.18.9 FECTL_REG—Fault Event Control Register

This register specifies the fault event interrupt message control bits. The VTd specification describes hardware handling of fault events.

B/D/F/Type:		0/2/0/GFXVTBAR	
Address Offset:		38–3Bh	
Reset Value:		80000000h	
Access:		RO, RW	
Bit	Attr	Reset Value	Description
31	RW	1b	<p>Interrupt Mask (IM)</p> <p>0 = No masking of interrupts. When an interrupt condition is detected, hardware issues an interrupt message (using the Fault Event Data & Fault Event Address register values).</p> <p>1 = This is the value on reset. Software may mask interrupt message generation by setting this field. Hardware is prohibited from sending the interrupt message when this field is set.</p>
30	RO	0b	<p>Interrupt Pending (IP)</p> <p>Hardware sets the IP field whenever it detects an interrupt condition, which is defined as:</p> <ul style="list-style-type: none"> When primary fault logging is active, an interrupt condition occurs when hardware records a fault through one of the Fault Recording registers and sets the PPF field in the Fault Status register. When advanced fault logging is active, an interrupt condition occurs when hardware records a fault in the first fault record (at index 0) of the current fault log and sets the APF field in the Fault Status register. Hardware detected error associated with the Invalidation Queue, setting the IQE field in the Fault Status register. Hardware detected invalid Device-IOTLB invalidation completion, setting the ICE field in the Fault Status register. Hardware detected Device-IOTLB invalidation completion time-out, setting the ITE field in the Fault Status register. <p>If any of the status fields in the Fault Status register was already Set at the time of setting any of these fields, it is not treated as a new interrupt condition.</p> <p>The IP field is kept Set by hardware while the interrupt message is held pending. The interrupt message could be held pending due to the interrupt mask (IM field) being Set or other transient hardware conditions.</p> <p>The IP field is cleared by hardware as soon as the interrupt message pending condition is serviced.</p> <p>This could be due to either:</p> <ul style="list-style-type: none"> Hardware issuing the interrupt message due to either a change in the transient hardware condition that caused the interrupt message to be held pending, or due to software clearing the IM field. Software servicing all the pending interrupt status fields in the Fault Status register as follows. <ul style="list-style-type: none"> When primary fault logging is active, software clearing the Fault (F) field in all the Fault Recording registers with faults, causing the PPF field in the Fault Status register to be evaluated as Clear. Software clearing other status fields in the Fault Status register by writing back the value read from the respective fields.
29:0	RO	00..00b	Reserved



2.18.10 FEDATA_REG—Fault Event Data Register

This register specifies the interrupt message data.

B/D/F/Type: 0/2/0/GFXVTBAR Address Offset: 3C–3Fh Reset Value: 00000000h Access: RO, RW			
Bit	Attr	Reset Value	Description
31:16	RO	0000h	Extended Interrupt Message Data (EID) This field is valid only for implementations supporting 32-bit interrupt data fields. Hardware implementations supporting only 16-bit interrupt data treat this field as reserved.
15:0	RW	0000h	Interrupt message data (ID) Data value in the interrupt request. Software requirements for programming this register are described in the VTd specification.

2.18.11 FEADDR_REG—Fault Event Address Register

This register specifies the interrupt message address.

B/D/F/Type: 0/2/0/GFXVTBAR Address Offset: 40–43h Reset Value: 0000_0000h Access: RW, RO			
Bit	Attr	Reset Value	Description
31:2	RW	0000_0000h	Message Address (MA) When fault events are enabled, the contents of this register specify the DWORD-aligned address (bits 31:2) for the interrupt request. Software requirements for programming this register are described in the VTd specification.
1:0	RO	00b	Reserved

2.18.12 FEUADDR_REG—Fault Event Upper Address Register

This register specifies the interrupt message upper address. This register is treated as reserved by implementations reporting Extended Interrupt Mode (EIM) as not supported in the Extended Capability register.

B/D/F/Type: 0/2/0/GFXVTBAR Address Offset: 44–47h Reset Value: 0000_0000h Access: RO			
Bit	Attr	Reset Value	Description
31:0	RO	0000_0000h	Message Upper Address (MUA) Hardware implementations supporting Extended Interrupt Mode are required to implement this register. Software requirements for programming this register are described in the VTd specification. Hardware implementations not supporting Extended Interrupt Mode may treat this field as reserved.



2.18.13 AFLOG_REG—Advanced Fault Log Register

This register specifies the base address of memory-resident fault-log region.

This register is treated as read-only (0) for implementations not supporting advanced translation fault logging (AFL field reported as 0 in the Capability register).

B/D/F/Type:		0/2/0/GFXVTBAR	
Address Offset:		58–5Fh	
Reset Value:		0000000000000000h	
Access:		RO	
Bit	Attr	Reset Value	Description
63:12	RO	00000000 00000h	Fault Log Address (FLA) This field specifies the base of 4KB aligned fault-log region in system memory. Hardware ignores and not implement bits 63:HAW, where HAW is the host address width. Software specifies the base address and size of the fault log region through this register, and programs it in hardware through the SFL field in the Global Command register. When implemented, reads of this field return the value that was last programmed to it.
11:9	RO	000b	Fault Log Size (FLS) This field specifies the size of the fault log region pointed to by the FLA field. The size of the fault log region is $(2^X) \times 4\text{KB}$, where X is the value programmed in this register. When implemented, reads of this field return the value that was last programmed to it.
8:0	RO	000h	Reserved



2.18.14 PMEN_REG—Protected Memory Enable Register

This register enables the DMA-protected memory regions set up through the PLMBASE, PLMLIMIT, PHMBASE, PHMLIMIT registers. This register is always treated as RO (0) for implementations not supporting protected memory regions (PLMR and PHMR fields reported as 0 in the Capability register).

Protected memory regions may be used by software to securely initialize remapping structures in memory.

B/D/F/Type:		0/2/0/GFXVTBAR	
Address Offset:		64–67h	
Reset Value:		00000000h	
Access:		RW, RO	
Bit	Attr	Reset Value	Description
31	RW	0b	<p>Enable Protected Memory Region (EPM)</p> <p>This field controls DMA accesses to the protected low-memory and protected high memory regions.</p> <p>0 = DMA accesses to protected memory regions are handled as follows:</p> <ul style="list-style-type: none"> — If DMA remapping is not enabled, DMA requests (including those to protected regions) are not blocked. — If DMA remapping is enabled, DMA requests are translated per the programming of the DMA remapping structures. Software may program the DMA-remapping structures to allow or block DMA to the protected memory regions. <p>1 = DMA accesses to protected memory regions are handled as follows:</p> <ul style="list-style-type: none"> — If DMA remapping is not enabled, DMA requests to protected memory regions are blocked. These DMA requests are not recorded or reported as DMA-remapping faults. — If DMA remapping is enabled, hardware may or may not block DMA to the protected memory region(s). Software must not depend on hardware protection of the protected memory regions, and must ensure the DMA-remapping structures are properly programmed to not allow DMA to the protected memory regions. <p>Hardware reports the status of the protected memory enable/disable operation through the PRS field in this register. Hardware implementations supporting DMA draining must drain any in-flight translated DMA requests queued within the Root-Complex before indicating the protected memory region as enabled through the PRS field.</p>
30:1	RO	00..00b	Reserved
0	RO	0b	<p>Protected Region Status (PRS)</p> <p>This field indicates the status of protected memory region(s):</p> <ul style="list-style-type: none"> 0 = Protected memory region(s) disabled. 1 = Protected memory region(s) enabled.



2.18.15 PLMBASE_REG—Protected Low Memory Base Register

This register is used to set up the base address of DMA-protected low-memory region below 4 GB. This register must be set up before enabling protected memory through PMEN_REG, and must not be updated when protected memory regions are enabled.

When the LT CMD.LOCK.PMRC command is invoked, this register is locked (treated as RO). When the LT CMD.UNLOCK.PMRC command is invoked, this register is unlocked (treated as RW). Refer to the VTd specification for security considerations.

This register is always treated as RO for implementations not supporting protected low memory region (PLMR field reported as 0 in the Capability register).

The alignment of the protected low memory region base depends on the number of reserved bits (N:0) of this register. Software may determine N by writing all 1s to this register, and finding the most significant bit position with 0 in the value read back from the register. Bits N:0 of this register are decoded by hardware as all 0s.

Software must setup the protected low memory region below 4 GB. The VTd specification describes the Protected Low-Memory Limit register and hardware decoding of these registers.

B/D/F/Type:		0/2/0/GFXVTBAR	
Address Offset:		68–6Bh	
Reset Value:		00000000h	
Access:		RO, RW	
Bit	Attr	Reset Value	Description
31:21	RW	000h	Protected Low-Memory Base (PLMB) This register specifies the base of protected low-memory region in system memory.
20:0	RO	000000h	Reserved

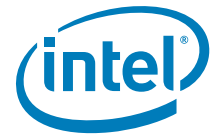

2.18.16 PLMLIMIT_REG—Protected Low Memory Limit Register

This register is used to set up the limit address of DMA-protected low-memory region below 4 GB. The register must be set up before enabling protected memory through PMEN_REG, and must not be updated when protected memory regions are enabled.

When the LT CMD.LOCK.PMRC command is invoked, this register is locked (treated as RO). When the LT CMD.UNLOCK.PMRC command is invoked, this register is unlocked (treated as RW). Refer to the VTd specification for security considerations.

This register is always treated as RO for implementations not supporting protected low memory region (PLMR field reported as 0 in the Capability register).

The alignment of the protected low memory region limit depends on the number of reserved bits (N:0) of this register. Software may determine N by writing all 1s to this register, and finding most significant zero bit position with 0 in the value read back from the register. Bits N:0 of the limit register are decoded by hardware as all 1s.

The Protected low-memory base and limit registers function as follows:

- Programming the protected low-memory base and limit registers the same value in bits 31:(N+1) specifies a protected low-memory region of size $2^{(N+1)}$ bytes.
- Programming the protected low-memory limit register with a value less than the protected low-memory base register disables the protected low-memory region.

B/D/F/Type:		0/2/0/GFXVTBAR	
Address Offset:		6C–6Fh	
Reset Value:		0000_0000h	
Access:		RW, RO	
Bit	Attr	Reset Value	Description
31:21	RW	000h	Protected Low-Memory Limit (PLML) This register specifies the last host physical address of the DMA-protected low-memory region in system memory.
20:0	RO	000000h	Reserved



2.18.17 PHMBASE_REG—Protected High Memory Base Register

This register is used to set up the base address of DMA-protected high-memory region. This register must be set up before enabling protected memory through PMEN_REG, and must not be updated when protected memory regions are enabled.

When the LT CMD.LOCK.PMRC command is invoked, this register is locked (treated as RO). When the LT CMD.UNLOCK.PMRC command is invoked, this register is unlocked (treated as RW).

This register is always treated as RO for implementations not supporting protected high memory region (PHMR field reported as 0 in the Capability register).

The alignment of the protected high memory region base depends on the number of reserved bits (N:0) of this register. Software may determine N by writing all 1s to this register, and finding most significant zero bit position below host address width (HAW) in the value read back from the register. Bits N:0 of this register are decoded by hardware as all 0s.

Software may setup the protected high memory region either above or below 4 GB.

B/D/F/Type:		0/2/0/GFXVTBAR	
Address Offset:		70–77h	
Reset Value:		0000000000000000h	
Access:		RO, RW	
Bit	Attr	Reset Value	Description
63:36	RO	0000000h	Reserved
35:21	RW	0000h	Protected High-Memory Base (PHMB) This register specifies the base of protected (high) memory region in system memory. Hardware ignores, and does not implement, bits 63:HAW, where HAW is the host address width.
20:0	RO	000000h	Reserved

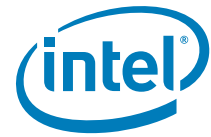

2.18.18 PHMLIMIT_REG—Protected High Memory Limit Register

This register is used to set up the limit address of DMA-protected high-memory region. The register must be set up before enabling protected memory through PMEN_REG, and must not be updated when protected memory regions are enabled.

When the LT CMD.LOCK.PMRC command is invoked, this register is locked (treated as RO). When the LT CMD.UNLOCK.PMRC command is invoked, this register is unlocked (treated as RW).

This register is always treated as RO for implementations not supporting protected high memory region (PHMR field reported as 0 in the Capability register).

The alignment of the protected high memory region limit depends on the number of reserved bits (N:0) of this register. Software may determine N by writing all 1's to this register, and finding most significant zero bit position below host address width (HAW) in the value read back from the register. Bits N:0 of the limit register are decoded by hardware as all 1s.

The protected high-memory base & limit registers function as follows.

- in bits HAW: (N+1) specifies a protected low-memory region of size $2^{(N+1)}$ bytes.
- Programming the protected high-memory limit register with a value less than the protected high-memory base register disables the protected high-memory region.

B/D/F/Type:		0/2/0/GFXVTBAR	
Address Offset:		78–7Fh	
Reset Value:		0000000000000000h	
Access:		RO, RW	
Bit	Attr	Reset Value	Description
63:36	RO	0000000h	Reserved
35:21	RW	0000h	Protected High-Memory Limit (PHML) This field specifies the last host physical address of the DMA-protected high-memory region in system memory. Hardware ignores and does not implement bits 63:HAW, where HAW is the host address width.
20:0	RO	000000h	Reserved



2.18.19 IQH_REG—Invalidation Queue Head Register

This register indicates the invalidation queue head. The register is treated as reserved by implementations reporting Queued Invalidation (QI) as not supported in the Extended Capability register.

B/D/F/Type:		0/2/0/GFXVTBAR	
Address Offset:		80–87h	
Reset Value:		0000000000000000h	
Access:		RO	
Bit	Attr	Reset Value	Description
63:19	RO	000000000000h	Reserved
18:4	RO	0000h	Queue Head (QH) Specifies the offset (128-bit aligned) to the invalidation queue for the command that will be fetched next by hardware. Hardware resets this field to 0 whenever the queued invalidation is disabled (QIES field Clear in the Global Status register).
3:0	RO	0h	Reserved

2.18.20 IQT_REG—Invalidation Queue Tail Register

This register indicates the invalidation tail head. The register is treated as reserved by implementations reporting Queued Invalidation (QI) as not supported in the Extended Capability register.

B/D/F/Type:		0/2/0/GFXVTBAR	
Address Offset:		88–8Fh	
Reset Value:		0000000000000000h	
Access:		RO	
Bit	Attr	Reset Value	Description
63:19	RO	000000000000h	Reserved
18:4	RO	0000h	Queue Tail (QT) Specifies the offset (128-bit aligned) to the invalidation queue for the command that will be written next by software.
3:0	RO	0h	Reserved



2.18.21 IQA_REG—Invalidation Queue Address Register

This register is used to configure the base address and size of the invalidation queue. The register is treated as reserved by implementations reporting Queued Invalidation (QI) as not supported in the Extended Capability register.

When supported, writing to this register causes the Invalidation Queue Head and Invalidation Queue Tail registers to be reset to 0h.

B/D/F/Type: 0/2/0/GFXVTBAR Address Offset: 90–97h Reset Value: 0000000000000000h Access: RO			
Bit	Attr	Reset Value	Description
63:12	RO	00..00b	Invalidation Queue Address (IQA) This field points to the base of 4 KB aligned invalidation request queue. Hardware ignores and not implement bits 63:HAW, where HAW is the host address width. Reads of this field return the value that was last programmed to it.
11:3	RO	000h	Reserved
2:0	RO	000b	Queue Size (QS) This field specifies the size of the invalidation request queue. A value of X in this field indicates an invalidation request queue of (X+1) 4 KB pages. The number of entries in the invalidation queue is $2^{(X + 8)}$.

2.18.22 ICS_REG—Invalidation Completion Status Register

This register reports completion status of invalidation wait descriptor with Interrupt Flag (IF) Set. The register is treated as reserved by implementations reporting Queued Invalidation (QI) as not supported in the Extended Capability register.

B/D/F/Type: 0/2/0/GFXVTBAR Address Offset: 9C–9Fh Reset Value: 00000000h Access: RO			
Bit	Attr	Reset Value	Description
31:1	RO	00..00b	Reserved
0	RO	0b	Invalidation Wait Descriptor Complete (IWC) This bit indicates completion of Invalidation Wait Descriptor with Interrupt Flag (IF) field Set. Hardware implementations not supporting queued invalidations implement this field as reserved.



2.18.23 IECTL_REG—Invalidation Completion Event Control Register

This register specifies the invalidation event interrupt control bits. The register is treated as reserved by implementations reporting Queued Invalidation (QI) as not supported in the Extended Capability register.

B/D/F/Type:		0/2/0/GFXVTBAR	
Address Offset:		A0–A3h	
Reset Value:		80000000h	
Access:		RO	
Bit	Attr	Reset Value	Description
31	RO	1b	<p>Interrupt Mask (IM)</p> <p>0 = No masking of interrupt. When a invalidation event condition is detected, hardware issues an interrupt message (using the Invalidation Event Data & Invalidation Event Address register values).</p> <p>1 = This is the value on reset. Software may mask interrupt message generation by setting this field. Hardware is prohibited from sending the interrupt message when this field is Set.</p>
30	RO	0b	<p>Interrupt Pending (IP)</p> <p>Hardware sets the IP field whenever it detects an interrupt condition. Interrupt condition is defined as:</p> <ul style="list-style-type: none"> An Invalidation Wait Descriptor with Interrupt Flag (IF) field Set completed, setting the IWC field in the Invalidation Completion Status register. If the IWC field in the Invalidation Completion Status register was already Set at the time of setting this field, it is not treated as a new interrupt condition. <p>The IP field is kept Set by hardware while the interrupt message is held pending. The interrupt message could be held pending due to interrupt mask (IM field) being Set, or due to other transient hardware conditions. The IP field is cleared by hardware as soon as the interrupt message pending condition is serviced. This could be due to either:</p> <ul style="list-style-type: none"> Hardware issuing the interrupt message due to either change in the transient hardware condition that caused interrupt message to be held pending or due to software clearing the IM field. Software servicing the IWC field in the Invalidation Completion Status register.
29:0	RO	00..00b	Reserved



2.18.24 IEDATA_REG—Invalidation Completion Event Data Register

This register specifies the Invalidation Event interrupt message data. The register is treated as reserved by implementations reporting Queued Invalidation (QI) as not supported in the Extended Capability register.

B/D/F/Type:		0/2/0/GFXVTBAR	
Address Offset:		A4–A7h	
Reset Value:		0000_0000h	
Access:		RO	
Bit	Attr	Reset Value	Description
31:16	RO	0000h	Extended Interrupt Message Data (EIMD) This field is valid only for implementations supporting 32-bit interrupt data fields. Hardware implementations supporting only 16-bit interrupt data treat this field as reserved.
15:0	RO	0000h	Interrupt Message Data (IMD) Data value in the interrupt request. Software requirements for programming this register are described in the VTd specification.

2.18.25 IEUADDR_REG—Invalidation Completion Event Upper Address Register

This register specifies the Invalidation Event interrupt message upper address. The register is treated as reserved by implementations reporting both Queued Invalidation (QI) and Extended Interrupt Mode (EIM) as not supported in the Extended Capability register.

B/D/F/Type:		0/2/0/GFXVTBAR	
Address Offset:		AC–AFh	
Reset Value:		0000_0000h	
Access:		RO	
Bit	Attr	Reset Value	Description
31:0	RO	0000_0000h	Message Upper Address (MUA) Hardware implementations supporting Queued Invalidation and Extended Interrupt Mode are required to implement this register. Software requirements for programming this register are described in the VTd specification. Hardware implementations not supporting Queued Invalidation and Extended Interrupt Mode may treat this field as reserved.



2.18.26 IRTA_REG—Interrupt Remapping Table Address Register

This register provides the base address of Interrupt remapping table. The register is treated as reserved by implementations reporting Interrupt Remapping (IR) as not supported in the Extended Capability register.

B/D/F/Type:		0/2/0/GFXVTBAR	
Address Offset:		B8–BFh	
Reset Value:		0000000000000000h	
Access:		RO	
Bit	Attr	Reset Value	Description
63:12	RO	00..00b	Interrupt Remapping Table Address (IRTA) This field points to the base of 4 KB aligned interrupt remapping table. Hardware ignores and not implement bits 63:HAW, where HAW is the host address width. Reads of this field returns value that was last programmed to it.
11	RO	0b	Extended Interrupt Mode Enable (EIME) 0 = Legacy interrupt mode is active. Hardware interprets only low 8 bits of Destination-ID field in the IRTes. The high 24 bits of the Destination-ID field is treated as reserved. On the processor platforms hardware interprets the low 16 bits of the Destination-ID field in the IRTes and treats the high 16 bits as reserved. 1 = Intel 64 platform is operating in Extended Interrupt Mode. Hardware interprets all 32 bits of the Destination-ID field in the IRTes. Hardware reporting Extended Interrupt Mode (EIM) as Clear in the Capability register treats this field as reserved.
10:4	RO	00h	Reserved
3:0	RO	0h	Size (S) This field specifies the size of the interrupt remapping table. The number of entries in the interrupt remapping table is $2^{(X+1)}$, where X is the value programmed in this field.



2.18.27 IVA_REG—Invalidate Address Register

This register provides the DMA address whose corresponding IOTLB entry needs to be invalidated through the corresponding IOTLB Invalidate register. The register is a write-only register. A value returned on a read of this register is undefined.

B/D/F/Type:		0/2/0/GFXVTBAR																															
Address Offset:		100–107h																															
Reset Value:		0000000000000000h																															
Access:		RO																															
Bit	Attr	Reset Value	Description																														
63:36	RO	0000000h	Reserved																														
35:12	RO	000000h	<p>Address (ADDR) Software provides the DMA address that needs to be page-selectively invalidated. To make a page-selective invalidation request to hardware, software must first write the appropriate fields in this register, and then issue appropriate page-selective invalidate command through the IOTLB_REG. Hardware ignores bits 63:N, where N is the maximum guest address width (MGAW) supported. Value returned on read of this field is undefined.</p>																														
11:7	RO	00h	Reserved																														
6	RO	0b	<p>Invalidation Hint (IH) The field provides hints to hardware about preserving or flushing the non-leaf (page directory) entries that may be cached in hardware: 0 = Software may have modified both leaf and non-leaf page-table entries corresponding to mappings specified in the ADDR and AM fields. On a page-selective invalidation request, hardware must flush both the cached leaf and non-leaf page-table entries corresponding to the mappings specified by ADDR and AM fields. 1 = Software has not modified any non-leaf page-table entries corresponding to mappings specified in the ADDR and AM fields. On a page-selective invalidation request, hardware may preserve the cached non-leaf page-table entries corresponding to the mappings specified by the ADDR and AM fields. A value returned on a read of this field is undefined.</p>																														
5:0	RO	00h	<p>Address Mask (AM) The value in this field specifies the number of low order bits of the ADDR field that must be masked for the invalidation operation. Mask field enables software to request invalidation of contiguous mappings for size-aligned regions. For example:</p> <table border="1"> <thead> <tr> <th>Mask Value</th> <th>ADDR bits masked</th> <th>Pages invalidated</th> </tr> </thead> <tbody> <tr><td>0</td><td>None</td><td>1</td></tr> <tr><td>1</td><td>12</td><td>2</td></tr> <tr><td>2</td><td>13:12</td><td>4</td></tr> <tr><td>3</td><td>14:12</td><td>8</td></tr> <tr><td>4</td><td>15:12</td><td>16</td></tr> <tr><td>5</td><td>16:12</td><td>32</td></tr> <tr><td>6</td><td>17:12</td><td>64</td></tr> <tr><td>7</td><td>18:12</td><td>128</td></tr> <tr><td>8</td><td>19:12</td><td>256</td></tr> </tbody> </table> <p>Hardware implementations report the maximum supported mask value through the Capability register. Value returned on read of this field is undefined.</p>	Mask Value	ADDR bits masked	Pages invalidated	0	None	1	1	12	2	2	13:12	4	3	14:12	8	4	15:12	16	5	16:12	32	6	17:12	64	7	18:12	128	8	19:12	256
Mask Value	ADDR bits masked	Pages invalidated																															
0	None	1																															
1	12	2																															
2	13:12	4																															
3	14:12	8																															
4	15:12	16																															
5	16:12	32																															
6	17:12	64																															
7	18:12	128																															
8	19:12	256																															



2.18.28 IOTLB_REG—IOTLB Invalidate Register

This register is used to invalidate IOTLB. The act of writing the upper byte of the IOTLB_REG with the IVT field Set causes the hardware to perform the IOTLB invalidation.

B/D/F/Type:		0/2/0/GFXVTBAR	
Address Offset:		108–10Fh	
Reset Value:		020000000000000h	
Access:		RW, RO	
Bit	Attr	Reset Value	Description
63	RW	0b	<p>Invalidate IOTLB (IVT)</p> <p>Software requests IOTLB invalidation by setting this field. Software must also set the requested invalidation granularity by programming the IIRG field. Hardware clears the IVT field to indicate the invalidation request is complete. Hardware also indicates the granularity at which the invalidation operation was performed through the IAIG field.</p> <p>Software must not submit another invalidation request through this register while the IVT field is Set, nor update the associated Invalidate Address register.</p> <p>Software must not submit IOTLB invalidation requests when there is a context-cache invalidation request pending at this remapping hardware unit. Refer to the VTd specification for software programming requirements.</p> <p>Hardware implementations reporting a write-buffer flushing requirement (RWBF=1 in Capability register) must implicitly perform a write buffer flushing before invalidating the IOTLB. Refer to the VTd specification for write buffer flushing requirements.</p>
62:60	RW	000b	<p>IOTLB Invalidation Request Granularity (IIRG)</p> <p>When requesting hardware to invalidate the IOTLB (by setting the IVT field), software writes the requested invalidation granularity through this field. The following are the encodings for the field.</p> <p>000 = Reserved.</p> <p>001 = Global invalidation request.</p> <p>010 = Domain-selective invalidation request. The target domain-id must be specified in the DID field.</p> <p>011 = Page-selective invalidation request. The target address, mask and invalidation hint must be specified in the Invalidate Address register, and the domain-id must be provided in the DID field.</p> <p>100 – 111 = Reserved.</p> <p>Hardware implementations may process an invalidation request by performing invalidation at a coarser granularity than requested. Hardware indicates completion of the invalidation request by clearing the IVT field. At that time, the granularity at which actual invalidation was performed is reported through the IAIG field.</p>
59:57	RO	001b	<p>IOTLB Actual Invalidation Granularity (IAIG)</p> <p>Hardware reports the granularity at which an invalidation request was processed through this field when reporting invalidation completion (by clearing the IVT field).</p> <p>The following are the encodings for this field.</p> <p>000 =Reserved. This indicates hardware detected an incorrect invalidation request and ignored the request. Examples of incorrect invalidation requests include detecting an unsupported address mask value in Invalidate Address register for page-selective invalidation requests.</p> <p>001 =Global Invalidation performed. This could be in response to a global, domain-selective, or page-selective invalidation request.</p> <p>010 =Domain-selective invalidation performed using the domain-id specified by software in the DID field. This could be in response to a domain-selective, or page-selective invalidation request.</p> <p>011 =Domain-page-selective invalidation performed using the address, mask and hint specified by software in the Invalidate Address register and domain-id specified in DID field. This can be in response to a page-selective invalidation request.</p> <p>100–111 = Reserved.</p>



B/D/F/Type:		0/2/0/GFXVTBAR	
Address Offset:		108–10Fh	
Reset Value:		0200000000000000h	
Access:		RW, RO	
Bit	Attr	Reset Value	Description
56:50	RO	00h	Reserved
49	RW	0b	<p>Drain Reads (DR)</p> <p>This field is ignored by hardware if the DRD field is reported as clear in the Capability register.</p> <p>When DRD field is reported as set in the Capability register, the following encodings are supported for this field:</p> <p>0 = Hardware may complete the IOTLB invalidation without draining DMA read requests.</p> <p>1 = Hardware must drain DMA read requests.</p> <p>Refer VTd specification for description of DMA draining.</p>
48	RW	0b	<p>Drain Writes (DW)</p> <p>This field is ignored by hardware if the DWD field is reported as clear in the Capability register.</p> <p>When DWD field is reported as set in the Capability register, the following encodings are supported for this field:</p> <p>0 = Hardware may complete the IOTLB invalidation without draining DMA write requests.</p> <p>1 = Hardware must drain relevant translated DMA write requests.</p> <p>Refer VTd specification for description of DMA draining.</p>
47:32	RW	0000h	<p>Domain-ID (DID)</p> <p>Indicates the ID of the domain whose IOTLB entries need to be selectively invalidated. This field must be programmed by software for domain-selective and page-selective invalidation requests.</p> <p>The Capability register reports the domain-id width supported by hardware. Software must ensure that the value written to this field is within this limit. Hardware ignores and not implement bits 47:(32+N), where N is the supported domain-id width reported in the Capability register.</p>
31:0	RO	0000_0000h	Reserved



2.18.29 FRCD_REG—Fault Recording Registers

Registers to record fault information when primary fault logging is active. Hardware reports the number and location of fault recording registers through the Capability register. This register is relevant only for primary fault logging.

These registers are sticky and can be cleared only through power good reset or by software clearing the RW1C fields by writing a 1.

B/D/F/Type:		0/2/0/GFXVTBAR	
Address Offset:		200–20Fh	
Reset Value:		00000000000000000000000000000000h	
Access:		RO-V-S, RO, RW1C-S	
Bit	Attr	Reset Value	Description
127	RW1C-S	0b	<p>Fault (F) Hardware sets this field to indicate a fault is logged in this Fault Recording register. The F field is Set by hardware after the details of the fault is recorded in other fields. When this field is Set, hardware may collapse additional faults from the same source-id (SID). Software writes the value read from this field to Clear it. Refer to the VTd specification for hardware details of primary fault logging.</p>
126	RO-V-S	0b	<p>Type (T) Type of the faulted request: 0 = Write request 1 = Read request This field is relevant only when the F field is Set, and when the fault reason (FR) indicates one of the DMA-remapping fault conditions.</p>
125:124	RO	00b	<p>Address Type (AT) This field captures the AT field from the faulted DMA request. Hardware implementations not supporting Device-IOTLBs (DI field Clear in Extended Capability register) treat this field as reserved. When supported, this field is valid only when the F field is Set, and when the fault reason (FR) indicates one of the DMA-remapping fault conditions.</p>
123:104	RO	00000h	Reserved
103:96	RO-V-S	00h	<p>Fault Reason (FR) Reason for the fault. The VT specification 1.2 Appendix enumerates the various translation fault reason encodings. This field is relevant only when the F field is set.</p>
95:80	RO	0000h	Reserved
79:64	RO-V-S	0000h	<p>Source Identifier (SID) Requester-id associated with the fault condition. This field is relevant only when the F field is Set.</p>
63:12	RO-V-S	00000000 00000h	<p>Page Address (PADDR) When the Fault Reason (FR) field indicates one of the DMA-remapping fault conditions, bits 63:12 of this field contains the page address in the faulted DMA request. Hardware treat bits 63:N as reserved (0), where N is the maximum guest address width (MGAW) supported. When the Fault Reason (FR) field indicates one of the interrupt-remapping fault conditions, bits 63:48 of this field indicate the interrupt_index computed for the faulted interrupt request, and bits 47:12 are cleared. This field is relevant only when the F field is Set.</p>
11:0	RO	000h	Reserved



2.18.30 VTPOLICY—VT Policy Register

B/D/F/Type:		0/2/0/GFXVTBAR	
Address Offset:		FFC–FFFh	
Reset Value:		4000_0000h	
Access:		RW-L, RW-O, RO	
Bit	Attr	Reset Value	Description
31	RW-O	0b	DMA Remap Engine Policy Lock-Down (DMAR_LCKDN) This register bit protects all the DMA remap engine specific policy configuration registers. Once this bit is set by software, all the DMA remap engine registers within the range F00h to FFCh will be read-only. This bit can only be clear through platform reset.
30	RO	1b	CI VT Level 2 Cache allocation mode (CIL2TLBMODE) 1 = Uniform replacement algorithm.
29	RW-L	0b	CI VT Level 2 Cache Disable (CIL2TLBDIS) This bit will disable caching of Level 2 HPA completions within CI if set.
28	RW-L	0b	CI VT Level 1 Cache Disable (CIL1TLBDIS) This bit will disable caching of Level 1 HPA completions within CI if set. 0 = Level 1 IOTLB is enabled and will be used to cache level 1 page table translations 1 = Level 1 IOTLB is disabled and will not be used to cache level 1 page table translation.
27	RW-L	0b	CI Remap Engine Policy Control (CIR_CTL) cic_scr_reserved_fault_en. 0 = "Default" Hardware support's reserved field programming faults in root, context and page translation structure (that is, fault code of Ah, Bh, Ch). 1 = Hardware ignores reserved field programming faults in the root, context and page translation structure.
26:5	RO	0h	Reserved
4	RW-L	0b	Level 1 Allocation Mode Selection (L1ALOCMODE) 0 = Enables Round Robin re-allocation mode. 1 = Enables LRU re-allocation mode.
3	RW-L	0b	Level 1 Cache LRU mode Selection (L1LRUMODE) 0 = Enables the LRU scheme to use a first avail starting from entry 0 to find one of the oldest entries when more than 1 are available. 1 = Enables the LRU scheme to use a first avail starting from a round robin selected entry.
2	RW-L	0b	Context Cache Disable (CCDIS) 0 = Context Cache is enabled and will be used to cache context translations 1 = Context Cache is disabled and will not be used to cache context translation.
1	RW-L	0b	Level 1 IOTLB Disable (L1TLBDIS) 0 = Level 1 IOTLB is enabled and will be used to cache level 1 page table translations 1 = Level 1 IOTLB is disabled and will not be used to cache level 1 page table translation.
0	RW-L	0b	Level 3 IOTLB Disable (L3TLBDIS) 0 = Level 3 IOTLB is enabled and will be used to cache level 3 page table translations 1 = Level 3 IOTLB is disabled and will not be used to cache level 3 page table translation.



2.19 PCI Device 6 Registers

Note: Device 6 is not supported on all SKUs.

Table 2-14. PCI Device 6 Register Address Map (Sheet 1 of 2)

Address Offset	Register Symbol	Register Name	Reset Value	Access
0–1h	VID6	Vendor Identification	8086h	RO
2–3h	DID6	Device Identification	0043h	RO
4–5h	PCICMD6	PCI Command	0000h	RO, RW
6–7h	PCISTS6	PCI Status	0010h	RO, RW1C
8h	RID6	Revision Identification	08h	RO
9–Bh	CC6	Class Code	060400h	RO
Ch	CL6	Cache Line Size	00h	RW
Eh	HDR6	Header Type	01h	RO
18h	PBUSN6	Primary Bus Number	00h	RO
19h	SBUSN6	Secondary Bus Number	00h	RW
1Ah	SUBUSN6	Subordinate Bus Number	00h	RW
1Ch	IOBASE6	I/O Base Address	F0h	RW, RO
1Dh	IOLIMIT6	I/O Limit Address	00h	RO, RW
1E–1Fh	SSTS6	Secondary Status	0000h	RW1C, RO
20–21h	MBASE6	Memory Base Address	FFF0h	RW, RO
22–23h	MLIMIT6	Memory Limit Address	0000h	RO, RW
24–25h	PMBASE6	Prefetchable Memory Base Address	FFF1h	RW, RO
26–27h	PMLIMIT6	Prefetchable Memory Limit Address	0001h	RO, RW
28–2Bh	PMBASEU6	Prefetchable Memory Base Address Upper	00000000h	RW
2C–2Fh	PMLIMITU6	Prefetchable Memory Limit Address Upper	00000000h	RW
34h	CAPPTR6	Capabilities Pointer	88h	RO
3Ch	INTRLINE6	Interrupt Line	00h	RW
3Dh	INTRPIN6	Interrupt Pin	01h	RO
3E–3Fh	BCTRL6	Bridge Control	0000h	RO, RW
40–7Eh	RSVD	Reserved	0h	RO
7Fh	CAPL	Capabilities List Control	02h	RW, RO
80–83h	PM_CAPID6	Power Management Capabilities	C8039001h	RO
84–87h	PM_CS6	Power Management Control/Status	00000008h	RO, RW, RW-S
88–8Bh	SS_CAPIDWs	Subsystem ID and Vendor ID Capabilities	0000800Dh	RO
8C–8Fh	SS	Subsystem ID and Subsystem Vendor ID	00008086h	RW-O
90–91h	MSI_CAPID	Message Signaled Interrupts Capability ID	A005h	RO
92–93h	MC	Message Control	0000h	RO, RW
94–97h	MA	Message Address	00000000h	RW, RO
98–99h	MD	Message Data	0000h	RW
A0–A1h	PEG_CAPL	PCI Express-G Capability List	0010h	RO
A2–A3h	PEG_CAP	PCI Express-G Capabilities	0142h	RO, RW-O



Table 2-14. PCI Device 6 Register Address Map (Sheet 2 of 2)

Address Offset	Register Symbol	Register Name	Reset Value	Access
A4–A7h	DCAP	Device Capabilities	00008000h	RO
A8–A9h	DCTL	Device Control	0000h	RW, RO
AA–ABh	DSTS	Device Status	0000h	RO, RW1C
AC–AFh	LCAP	Link Capabilities	03214C82h	RO, RW-O
B0–B1h	LCTL	Link Control	0000h	RW, RO, RW-SC
B2–B3h	LSTS	Link Status	1000h	RO, RW1C
B4–B7h	SLOTCAP	Slot Capabilities	00040000h	RW-O, RO
B8–B9h	SLOTCTL	Slot Control	0000h	RO, RW
BA–BBh	SLOTSTS	Slot Status	0000h	RO, RW1C
BC–BDh	RCTL	Root Control	0000h	RO, RW
C0–C3h	RSTS	Root Status	00000000h	RO, RW1C
EC–EFh	PEGLC	PCI Express-G Legacy Control	00000000h	RO, RW

2.19.1 VID6—Vendor Identification Register

This register, combined with the Device Identification register, uniquely identify any PCI device.

B/D/F/Type:		0/6/0/PCI	
Address Offset:		0–1h	
Reset Value:		8086h	
Access:		RO	
Bit	Attr	Reset Value	Description
15:0	RO	8086h	Vendor Identification (VID6) PCI standard identification for Intel.



2.19.2 DID6—Device Identification Register

This register combined with the Vendor Identification register uniquely identifies any PCI device.

B/D/F/Type:		0/6/0/PCI	
Address Offset:		2–3h	
Reset Value:		0043h	
Access:		RO	
Bit	Attr	Reset Value	Description
15:4	RO	004h	Device Identification Number Upper Bits (DID6UB) Identifier assigned to device 6 (virtual PCI-to-PCI bridge, PCI Express Graphics port).
3:2	RO	00b	Device Identification Number Hardware controlled (DID6HW) Identifier assigned to the device 6 (virtual PCI-to-PCI bridge, PCI Express Graphics port).
1:0	RO	11b	Device Identification Number Lower Bits (DID6LB) Identifier assigned to the device 6 (virtual PCI-to-PCI bridge, PCI Express Graphics port).

2.19.3 PCICMD6—PCI Command Register

B/D/F/Type:		0/6/0/PCI	
Address Offset:		4–5h	
Reset Value:		0000h	
Access:		RO, RW	
Bit	Attr	Reset Value	Description
15:11	RO	00h	Reserved
10	RW	0b	INTA Assertion Disable (INTAAD) 0 = This device is permitted to generate INTA interrupt messages. 1 = This device is prevented from generating interrupt messages. Any INTA emulation interrupts already asserted must be de-asserted when this bit is set. Only affects interrupts generated by the device (PCI INTA from a PME or Hot Plug event) controlled by this command register. It does not affect upstream MSIs, upstream PCI INTA-INTD assert and de-assert messages.
9	RO	0b	Fast Back-to-Back Enable (FB2B) Not Applicable or Implemented. Hardwired to 0.
8	RW	0b	SERR# Message Enable (SERRE6) This bit controls Device 6 SERR# messaging. The root port communicates the SERR# condition by sending an SERR message to the PCH. This bit, when set, enables reporting of non-fatal and fatal errors detected by the device to the Root Complex. Note that errors are reported if enabled either through this bit or through the PCI-Express specific bits in the Device Control Register. In addition, for Type 1 configuration space header devices, this bit, when set, enables transmission by the primary interface of ERR_NONFATAL and ERR_FATAL error messages forwarded from the secondary interface. This bit does not affect the transmission of forwarded ERR_COR messages. 0 = The SERR message is generated by the root port only under conditions enabled individually through the Device Control Register. 1 = The root port is enabled to generate SERR messages which will be sent to the PCH for specific root port error conditions generated/detected or received on the secondary side of the virtual PCI to PCI bridge. The status of SERRs generated is reported in the PCISTS6 register.

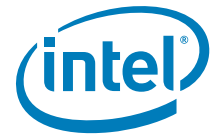

B/D/F/Type:		0/6/0/PCI	
Address Offset:		4–5h	
Reset Value:		0000h	
Access:		RO, RW	
Bit	Attr	Reset Value	Description
7	RO	0b	Reserved Not Applicable or Implemented. Hardwired to 0.
6	RW	0b	Parity Error Response Enable (PERRE) Controls whether or not the Master Data Parity Error bit in the PCI Status register can be set. 0 = Master Data Parity Error bit in PCI Status register can NOT be set. 1 = Master Data Parity Error bit in PCI Status register CAN be set.
5	RO	0b	VGA Palette Snoop (VGAPS) Not Applicable or Implemented. Hardwired to 0.
4	RO	0b	Memory Write and Invalidate Enable (MWIE) Not Applicable or Implemented. Hardwired to 0.
3	RO	0b	Special Cycle Enable (SCE) Not Applicable or Implemented. Hardwired to 0.
2	RW	0b	Bus Master Enable (BME) This bit controls the ability of the PEG port to forward Memory and IO Read/Write Requests in the upstream direction. 0 = This device is prevented from making memory or IO requests to its primary bus. Note that according to PCI Specification, as MSI interrupt messages are in-band memory writes, disabling the bus master enable bit prevents this device from generating MSI interrupt messages or passing them from its secondary bus to its primary bus. Upstream memory writes/reads, IO writes/reads, peer writes/reads, and MSIs will all be treated as illegal cycles. Writes are forwarded to memory address C0000h with byte enables de-asserted. Reads will be forwarded to memory address C0000h and will return Unsupported Request status (or Master abort) in its completion packet. 1 = This device is allowed to issue requests to its primary bus. Completions for previously issued memory read requests on the primary bus will be issued when the data is available. This bit does not affect forwarding of Completions from the primary interface to the secondary interface.
1	RW	0b	Memory Access Enable (MAE) 0 = All of device 6's memory space is disabled. 1 = Enable the Memory and Pre-fetchable memory address ranges defined in the MBASE6, MLIMIT6, PMBASE6, and PMLIMIT6 registers.
0	RW	0b	IO Access Enable (IOAE) 0 = All of device 6's I/O space is disabled. 1 = Enable the I/O address range defined in the IOBASE6, and IOLIMIT6 registers.



2.19.4 PCISTS6—PCI Status Register

This register reports the occurrence of error conditions associated with primary side of the "virtual" Host-PCI Express bridge embedded within the GMCH.

B/D/F/Type:		0/6/0/PCI	
Address Offset:		6–7h	
Reset Value:		0010h	
Access:		RO, RW1C	
Bit	Attr	Reset Value	Description
15	RO	0b	Detected Parity Error (DPE) Not Applicable or Implemented. Hardwired to 0. Parity (generating poisoned TLPs) is not supported on the primary side of this device (we don't do error forwarding).
14	RW1C	0b	Signaled System Error (SSE) This bit is set when this Device sends an SERR due to detecting an ERR_FATAL or ERR_NONFATAL condition and the SERR Enable bit in the Command register is '1'. Both received (if enabled by BCTRL6[1]) and internally detected error messages do not affect this field.
13	RO	0b	Received Master Abort Status (RMAS) Not Applicable or Implemented. Hardwired to 0. The concept of a master abort does not exist on primary side of this device.
12	RO	0b	Received Target Abort Status (RTAS) Not Applicable or Implemented. Hardwired to 0. The concept of a target abort does not exist on primary side of this device.
11	RO	0b	Signaled Target Abort Status (STAS) Not Applicable or Implemented. Hardwired to 0. The concept of a target abort does not exist on primary side of this device.
10:9	RO	00b	DEVSELB Timing (DEVT) This device is not the subtractively decoded device on bus 0. This bit field is therefore hardwired to 00 to indicate that the device uses the fastest possible decode.
8	RO	0b	Master Data Parity Error (PMDPE) Because the primary side of the PEG's virtual P2P bridge is integrated with the MCH functionality there is no scenario where this bit will get set. Because hardware will never set this bit, it is impossible for software to have an opportunity to clear this bit or otherwise test that it is implemented. The PCI specification defines it as a R/WC, but for our implementation an RO definition behaves the same way and will meet all Microsoft testing requirements. This bit can only be set when the Parity Error Enable bit in the PCI Command register is set.
7	RO	0b	Fast Back-to-Back (FB2B) Not Applicable or Implemented. Hardwired to 0.
6	RO	0b	Reserved
5	RO	0b	66/60MHz capability (CAP66) Not Applicable or Implemented. Hardwired to 0.
4	RO	1b	Capabilities List (CAPL) Indicates that a capabilities list is present. Hardwired to 1.
3	RO	0b	INTA Status (INTAS) This bit indicates that an interrupt message is pending internally to the device. Only PME and Hot Plug sources feed into this status bit (not PCI INTA-INTD assert and de-assert messages). The INTA Assertion Disable bit, PCICMD6[10], has no effect on this bit. Note that INTA emulation interrupts received across the link are not reflected in this bit.
2:0	RO	000b	Reserved



2.19.5 RID6—Revision Identification Register

This register contains the revision number of the processor. The Revision ID (RID) is a traditional 8-bit Read Only (RO) register located at offset 08h in the standard PCI header of every PCI/PCI Express compatible device and function.

This register contains the revision number of Device 6. These bits are read only and writes to this register have no effect.

B/D/F/Type:		0/6/0/PCI	
Address Offset:		8h	
Reset Value:		08h	
Access:		RO	
Bit	Attr	Reset Value	Description
7:0	RO	08h	Revision Identification Number (RID6) This is an 8-bit value that indicates the revision identification number for the Device 6. Refer to the <i>Intel® Core™ i5-600 and i3-500 Desktop Processor Series and Intel® Pentium® Desktop Processor 6000 Series Specification Update</i> for the value of the Revision ID Register.

2.19.6 CC6—Class Code Register

This register identifies the basic function of the device, a more specific sub-class, and a register-specific programming interface.

B/D/F/Type:		0/6/0/PCI	
Address Offset:		9–Bh	
Reset Value:		060400h	
Access:		RO	
Bit	Attr	Reset Value	Description
23:16	RO	06h	Base Class Code (BCC) Indicates the base class code for this device. This code has the value 06h, indicating a Bridge device.
15:8	RO	04h	Sub-Class Code (SUBCC) Indicates the sub-class code for this device. The code is 04h indicating a PCI to PCI Bridge.
7:0	RO	00h	Programming Interface (PI) Indicates the programming interface of this device. This value does not specify a particular register set layout and provides no practical use for this device.



2.19.7 CL6—Cache Line Size Register

B/D/F/Type:		0/6/0/PCI	
Address Offset:		Ch	
Reset Value:		00h	
Access:		RW	
Bit	Attr	Reset Value	Description
7:0	RW	00h	Cache Line Size (Scratch pad) Implemented by PCI Express devices as a read-write field for legacy compatibility purposes but has no impact on any PCI Express device functionality.

2.19.8 HDR6—Header Type Register

This register identifies the header layout of the configuration space. No physical register exists at this location.

B/D/F/Type:		0/6/0/PCI	
Address Offset:		Eh	
Reset Value:		01h	
Access:		RO	
Bit	Attr	Reset Value	Description
7:0	RO	01h	Header Type Register (HDR) This field returns 01 to indicate that this is a single function device with bridge header layout.

2.19.9 PBUSN6—Primary Bus Number Register

This register identifies that this "virtual" Host-PCI Express bridge is connected to PCI bus 0.

B/D/F/Type:		0/6/0/PCI	
Address Offset:		18h	
Reset Value:		00h	
Access:		RO	
Bit	Attr	Reset Value	Description
7:0	RO	00h	Primary Bus Number (BUSN) Configuration software typically programs this field with the number of the bus on the primary side of the bridge. Since device 6 is an internal device and its primary bus is always 0, these bits are read only and are hardwired to 0.

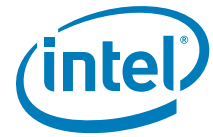

2.19.10 SBUSN6—Secondary Bus Number Register

This register identifies the bus number assigned to the second bus side of the "virtual" bridge (that is, to PCI Express-G). This number is programmed by the PCI configuration software to allow mapping of configuration cycles to PCI Express-G.

B/D/F/Type:		0/6/0/PCI	
Address Offset:		19h	
Reset Value:		00h	
Access:		RW	
Bit	Attr	Reset Value	Description
7:0	RW	00h	Secondary Bus Number (BUSN) This field is programmed by configuration software with the bus number assigned to PCI Express-G.

2.19.11 SUBUSN6—Subordinate Bus Number Register

This register identifies the subordinate bus (if any) that resides at the level below PCI Express-G. This number is programmed by the PCI configuration software to allow mapping of configuration cycles to PCI Express-G.

B/D/F/Type:		0/6/0/PCI	
Address Offset:		1Ah	
Reset Value:		00h	
Access:		RW	
Bit	Attr	Reset Value	Description
7:0	RW	00h	Subordinate Bus Number (BUSN) This register is programmed by configuration software with the number of the highest subordinate bus that lies behind the device 6 bridge. When only a single PCI device resides on the PCI Express-G segment, this register will contain the same value as the SBUSN6 register.



2.19.12 IOBASE6—I/O Base Address Register

This register controls the processor to PCI Express-G I/O access routing based on the following formula:

$$\text{IO_BASE} \leq \text{address} \leq \text{IO_LIMIT}$$

Only upper 4 bits are programmable. For the purpose of address decode, address bits A[11:0] are treated as 0. Thus the bottom of the defined I/O address range will be aligned to a 4 KB boundary.

B/D/F/Type:		0/6/0/PCI	
Address Offset:		1Ch	
Reset Value:		Fh	
Access:		RW, RO	
Bit	Attr	Reset Value	Description
7:4	RW	Fh	I/O Address Base (IOBASE) This field corresponds to A[15:12] of the I/O addresses passed by bridge 1 to PCI Express-G. BIOS must not set this register to 00h otherwise 0CF8h/0CFCh accesses will be forwarded to the PCI Express hierarchy associated with this device.
3:0	RO	0h	Reserved

2.19.13 IOLIMIT6—I/O Limit Address Register

This register controls the processor to PCI Express-G I/O access routing based on the following formula:

$$\text{IO_BASE} \leq \text{address} \leq \text{IO_LIMIT}$$

Only upper 4 bits are programmable. For the purpose of address decode, address bits A[11:0] are assumed to be FFFh. Thus, the top of the defined I/O address range will be at the top of a 4 KB aligned address block.

B/D/F/Type:		0/6/0/PCI	
Address Offset:		1Dh	
Reset Value:		00h	
Access:		RO, RW	
Bit	Attr	Reset Value	Description
7:4	RW	0h	I/O Address Limit (IOLIMIT) This field corresponds to A[15:12] of the I/O address limit of device 6. Devices between this upper limit and IOBASE6 will be passed to the PCI Express hierarchy associated with this device.
3:0	RO	0h	Reserved



2.19.14 SSTS6—Secondary Status Register

SSTS6 is a 16-bit status register that reports the occurrence of error conditions associated with secondary side (that is, PCI Express-G side) of the "virtual" PCI-PCI bridge embedded within GMCH.

B/D/F/Type:		0/6/0/PCI	
Address Offset:		1E–1Fh	
Reset Value:		0000h	
Access:		RW1C, RO	
Bit	Attr	Reset Value	Description
15	RW1C	0b	Detected Parity Error (DPE) This bit is set by the Secondary Side for a Type 1 Configuration Space header device whenever it receives a Poisoned TLP, regardless of the state of the Parity Error Response Enable bit in the Bridge Control Register.
14	RW1C	0b	Received System Error (RSE) This bit is set when the Secondary Side for a Type 1 configuration space header device receives an ERR_FATAL or ERR_NONFATAL.
13	RW1C	0b	Received Master Abort (RMA) This bit is set when the Secondary Side for Type 1 Configuration Space Header Device (for requests initiated by the Type 1 Header Device itself) receives a Completion with Unsupported Request Completion Status.
12	RW1C	0b	Received Target Abort (RTA) This bit is set when the Secondary Side for Type 1 Configuration Space Header Device (for requests initiated by the Type 1 Header Device itself) receives a Completion with Completer Abort Completion Status.
11	RO	0b	Signaled Target Abort (STA) Not Applicable or Implemented. Hardwired to 0. The GMCH does not generate Target Aborts (the GMCH will never complete a request using the Completer Abort Completion status).
10:9	RO	00b	DEVSELB Timing (DEVT) Not Applicable or Implemented. Hardwired to 0.
8	RW1C	0b	Master Data Parity Error (SMDPE) When set indicates that the MCH received across the link (upstream) a Read Data Completion Poisoned TLP (EP=1). This bit can only be set when the Parity Error Enable bit in the Bridge Control register is set.
7	RO	0b	Fast Back-to-Back (FB2B) Not Applicable or Implemented. Hardwired to 0.
6	RO	0b	Reserved
5	RO	0b	66/60 MHz capability (CAP66) Not Applicable or Implemented. Hardwired to 0.
4:0	RO	00h	Reserved



2.19.15 MBASE6—Memory Base Address Register

This register controls the processor to PCI Express-G non-prefetchable memory access routing based on the following formula:

$$\text{MEMORY_BASE} \leq \text{address} \leq \text{MEMORY_LIMIT}$$

The upper 12 bits of the register are read/write and correspond to the upper 12 address bits A[31:20] of the 32 bit address. The bottom 4 bits of this register are read-only and return zeroes when read. This register must be initialized by the configuration software. For the purpose of address decode, address bits A[19:0] are assumed to be 0. Thus, the bottom of the defined memory address range will be aligned to a 1 MB boundary.

B/D/F/Type:		0/6/0/PCI	
Address Offset:		20–21h	
Reset Value:		FFF0h	
Access:		RW, RO	
Bit	Attr	Reset Value	Description
15:4	RW	FFFh	Memory Address Base (MBASE) This field corresponds to A[31:20] of the lower limit of the memory range that will be passed to PCI Express-G.
3:0	RO	0h	Reserved



2.19.16 MLIMIT6—Memory Limit Address Register

This register controls the processor to PCI Express-G non-prefetchable memory access routing based on the following formula:

$$\text{MEMORY_BASE} \leq \text{address} \leq \text{MEMORY_LIMIT}$$

The upper 12 bits of the register are read/write and correspond to the upper 12 address bits A[31:20] of the 32 bit address. The bottom 4 bits of this register are read-only and return zeroes when read. This register must be initialized by the configuration software. For the purpose of address decode, address bits A[19:0] are assumed to be FFFFh. Thus, the top of the defined memory address range will be at the top of a 1 MB aligned memory block.

Note: Memory range covered by MBASE and MLIMIT registers are used to map non-prefetchable PCI Express-G address ranges (typically where control/status memory-mapped I/O data structures of the graphics controller will reside) and PMBASE and PMLIMIT are used to map prefetchable address ranges (typically graphics local memory). This segregation allows application of USWC space attribute to be performed in a true plug-and-play manner to the prefetchable address range for improved processor - PCI Express memory access performance.

Note: Configuration software is responsible for programming all address range registers (prefetchable, non-prefetchable) with the values that provide exclusive address ranges (that is, prevent overlap with each other and/or with the ranges covered with the main memory). There is no provision in the GMCH hardware to enforce prevention of overlap and operations of the system in the case of overlap are not ensured.

B/D/F/Type:		0/6/0/PCI	
Address Offset:		22–23h	
Reset Value:		0000h	
Access:		RO, RW	
Bit	Attr	Reset Value	Description
15:4	RW	000h	Memory Address Limit (MLIMIT) This field corresponds to A[31:20] of the upper limit of the address range passed to PCI Express-G.
3:0	RO	0h	Reserved



2.19.17 PMBASE6—Prefetchable Memory Base Address Register

This register in conjunction with the corresponding Upper Base Address register controls the processor to PCI Express-G prefetchable memory access routing based on the following formula:

$$\text{PREFETCHABLE_MEMORY_BASE} \leq \text{address} \leq \text{PREFETCHABLE_MEMORY_LIMIT}$$

The upper 12 bits of this register are read/write and correspond to address bits A[31:20] of the 40-bit address. The lower 8 bits of the Upper Base Address register are read/write and correspond to address bits A[39:32] of the 40-bit address. This register must be initialized by the configuration software. For the purpose of address decode address bits A[19:0] are assumed to be 0. Thus, the bottom of the defined memory address range will be aligned to a 1 MB boundary.

B/D/F/Type:		0/6/0/PCI	
Address Offset:		24-25h	
Reset Value:		FFF1h	
Access:		RW, RO	
Bit	Attr	Reset Value	Description
15:4	RW	FFFh	Prefetchable Memory Base Address (MBASE) This field corresponds to A[31:20] of the lower limit of the memory range that will be passed to PCI Express-G.
3:0	RO	1h	64-bit Address Support (Reserved) This field indicates that the upper 32 bits of the prefetchable memory region base address are contained in the Prefetchable Memory base Upper Address register at 28h.

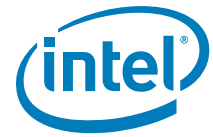

2.19.18 PMLIMIT6—Prefetchable Memory Limit Address Register

This register in conjunction with the corresponding Upper Limit Address register controls the processor to PCI Express-G prefetchable memory access routing based on the following formula:

$$\text{PREFETCHABLE_MEMORY_BASE} \leq \text{address} \leq \text{PREFETCHABLE_MEMORY_LIMIT}$$

The upper 12 bits of this register are read/write and correspond to address bits A[31:20] of the 40-bit address. The lower 8 bits of the Upper Limit Address register are read/write and correspond to address bits A[39:32] of the 40-bit address. This register must be initialized by the configuration software. For the purpose of address decode, address bits A[19:0] are assumed to be FFFFh. Thus, the top of the defined memory address range will be at the top of a 1 MB aligned memory block. Note that prefetchable memory range is supported to allow segregation by the configuration software between the memory ranges that must be defined as UC and the ones that can be designated as a USWC (that is, prefetchable) from the processor perspective.

B/D/F/Type:		0/6/0/PCI	
Address Offset:		26–27h	
Reset Value:		0001h	
Access:		RO, RW	
Bit	Attr	Reset Value	Description
15:4	RW	000h	Prefetchable Memory Address Limit (PMLIMIT) This field corresponds to A[31:20] of the upper limit of the address range passed to PCI Express-G.
3:0	RO	1h	64-bit Address Support (Reserved) Indicates that the upper 32 bits of the prefetchable memory region limit address are contained in the Prefetchable Memory Base Limit Address register at 2Ch.



2.19.19 PMBASEU6—Prefetchable Memory Base Address Upper Register

The functionality associated with this register is present in the PEG design implementation.

This register in conjunction with the corresponding Upper Base Address register controls the processor to PCI Express-G prefetchable memory access routing based on the following formula:

$$\text{PREFETCHABLE_MEMORY_BASE} \leq \text{address} \leq \text{PREFETCHABLE_MEMORY_LIMIT}$$

The upper 12 bits of this register are read/write and correspond to address bits A[31:20] of the 40-bit address. The lower 8 bits of the Upper Base Address register are read/write and correspond to address bits A[39:32] of the 40-bit address. This register must be initialized by the configuration software. For the purpose of address decode, address bits A[19:0] are assumed to be 0. Thus, the bottom of the defined memory address range will be aligned to a 1 MB boundary.

B/D/F/Type:		0/6/0/PCI	
Address Offset:		28–2Bh	
Reset Value:		0000_0000h	
Access:		RW	
Bit	Attr	Reset Value	Description
31:0	RW	0000_0000h	Prefetchable Memory Base Address (MBaseU) This field corresponds to A[63:32] of the lower limit of the prefetchable memory range that will be passed to PCI Express-G.



2.19.20 PMLIMITU6—Prefetchable Memory Limit Address Upper Register

The functionality associated with this register is present in the PEG design implementation.

This register in conjunction with the corresponding Upper Limit Address register controls the processor to PCI Express-G prefetchable memory access routing based on the following formula:

$$\text{PREFETCHABLE_MEMORY_BASE} \leq \text{address} \leq \text{PREFETCHABLE_MEMORY_LIMIT}$$

The upper 12 bits of this register are read/write and correspond to address bits A[31:20] of the 40-bit address. The lower 8 bits of the Upper Limit Address register are read/write and correspond to address bits A[39:32] of the 40-bit address. This register must be initialized by the configuration software. For the purpose of address decode, address bits A[19:0] are assumed to be FFFFh. Thus, the top of the defined memory address range will be at the top of a 1 MB aligned memory block.

Note that prefetchable memory range is supported to allow segregation by the configuration software between the memory ranges that must be defined as UC and the ones that can be designated as a USWC (that is, prefetchable) from the processor perspective.

B/D/F/Type:		0/6/0/PCI	
Address Offset:		2C–2Fh	
Reset Value:		00000000h	
Access:		RW	
Bit	Attr	Reset Value	Description
31:0	RW	00000000h	Prefetchable Memory Address Limit (MLIMITU) This field corresponds to A[63:32] of the upper limit of the prefetchable Memory range that will be passed to PCI Express-G.

2.19.21 CAPPTR6—Capabilities Pointer Register

The capabilities pointer provides the address offset to the location of the first entry in this device's linked list of capabilities.

B/D/F/Type:		0/6/0/PCI	
Address Offset:		34h	
Reset Value:		88h	
Access:		RO	
Bit	Attr	Reset Value	Description
7:0	RO	88h	First Capability (CAPPTR1) The first capability in the list is the Subsystem ID and Subsystem Vendor ID Capability.



2.19.22 INTRLINE6—Interrupt Line Register

This register contains interrupt line routing information. The device itself does not use this value, rather it is used by device drivers and operating systems to determine priority and vector information.

B/D/F/Type:		0/6/0/PCI	
Address Offset:		3Ch	
Reset Value:		00h	
Access:		RW	
Bit	Attr	Reset Value	Description
7:0	RW	00h	Interrupt Connection (INTCON) This field is used to communicate interrupt line routing information. BIOS Requirement: POST software writes the routing information into this register as it initializes and configures the system. The value indicates to which input of the system interrupt controller this device's interrupt pin is connected.

2.19.23 INTRPIN6—Interrupt Pin Register

This register specifies which interrupt pin this device uses.

B/D/F/Type:		0/6/0/PCI	
Address Offset:		3Dh	
Reset Value:		01h	
Access:		RO	
Bit	Attr	Reset Value	Description
7:0	RO	01h	Interrupt Pin (INTPIN) As a single function device, the PCI Express device specifies INTA as its interrupt pin. 01h=INTA.

2.19.24 BCTRL6—Bridge Control Register

This register provides extensions to the PCICMD6 register that are specific to PCI-PCI bridges. The BCTRL provides additional control for the secondary interface (that is, PCI Express-G) as well as some bits that affect the overall behavior of the "virtual" Host-PCI Express bridge embedded within GMCH (such as, VGA compatible address ranges mapping).

B/D/F/Type:		0/6/0/PCI	
Address Offset:		3E–3Fh	
Reset Value:		0000h	
Access:		RO, RW	
Bit	Attr	Reset Value	Description
15:12	RO	0h	Reserved
11	RO	0b	Discard Timer SERR# Enable (DTSERRE) Not Applicable or Implemented. Hardwired to 0.
10	RO	0b	Discard Timer Status (DTSTS) Not Applicable or Implemented. Hardwired to 0.



B/D/F/Type:		0/6/0/PCI	
Address Offset:		3E–3Fh	
Reset Value:		0000h	
Access:		RO, RW	
Bit	Attr	Reset Value	Description
9	RO	0b	Secondary Discard Timer (SDT) Not Applicable or Implemented. Hardwired to 0.
8	RO	0b	Primary Discard Timer (PDT) Not Applicable or Implemented. Hardwired to 0.
7	RO	0b	Fast Back-to-Back Enable (FB2BEN) Not Applicable or Implemented. Hardwired to 0.
6	RW	0b	Secondary Bus Reset (SRESET) Setting this bit triggers a hot reset on the corresponding PCI Express Port. This will force the LTSSM to transition to the Hot Reset state (using Recovery) from L0, L0s, or L1 states.
5	RO	0b	Master Abort Mode (MAMODE) Does not apply to PCI Express. Hardwired to 0.
4	RW	0b	VGA 16-bit Decode (VGA16D) Enables the PCI-to-PCI bridge to provide 16-bit decoding of VGA I/O address precluding the decoding of alias addresses every 1 KB. This bit only has meaning if bit 3 (VGA Enable) of this register is also set to 1, enabling VGA I/O decoding and forwarding by the bridge. 0 = Execute 10-bit address decodes on VGA I/O accesses. 1 = Execute 16-bit address decodes on VGA I/O accesses.
3	RW	0b	VGA Enable (VGAEN) This bit controls the routing of processor initiated transactions targeting VGA compatible I/O and memory address ranges. See the VGAEN/MDAP table in device 0, offset 97h[0].
2	RW	0b	ISA Enable (ISAEN) Needed to exclude legacy resource decode to route ISA resources to legacy decode path. Modifies the response by the GMCH to an I/O access issued by the processor that target ISA I/O addresses. This applies only to I/O addresses that are enabled by the IOBASE and IOLIMIT registers. 0 = All addresses defined by the IOBASE and IOLIMIT for processor I/O transactions will be mapped to PCI Express-G. 1 = GMCH will not forward to PCI Express-G any I/O transactions addressing the last 768 bytes in each 1 KB block even if the addresses are within the range defined by the IOBASE and IOLIMIT registers.
1	RW	0b	SERR Enable (SERREN) 0 = No forwarding of error messages from secondary side to primary side that could result in an SERR. 1 = ERR_COR, ERR_NONFATAL, and ERR_FATAL messages result in SERR message when individually enabled by the Root Control register.
0	RW	0b	Parity Error Response Enable (PEREN) This bit controls whether or not the Master Data Parity Error bit in the Secondary Status register is set when the MCH receives across the link (upstream) a Read Data Completion Poisoned TLP. 0 = Master Data Parity Error bit in Secondary Status register can NOT be set.. 1 = Master Data Parity Error bit in Secondary Status register CAN be set.



2.19.25 PM_CAPID6—Power Management Capabilities Register

B/D/F/Type:		0/6/0/PCI	
Address Offset:		80–83h	
Reset Value:		C8039001h	
Access:		RO	
Bit	Attr	Reset Value	Description
31:27	RO	19h	PME Support (PMES) This field indicates the power states in which this device may indicate PME wake using PCI Express messaging. D0, D3hot & D3cold. This device is not required to do anything to support D3hot & D3cold, it simply must report that those states are supported. Refer to the PCI Power Management 1.1 specification for encoding explanation and other power management details.
26	RO	0b	D2 Power State Support (D2PSS) Hardwired to 0 to indicate that the D2 power management state is NOT supported.
25	RO	0b	D1 Power State Support (D1PSS) Hardwired to 0 to indicate that the D1 power management state is NOT supported.
24:22	RO	000b	Auxiliary Current (AUXC) Hardwired to 0 to indicate that there are no 3.3Vaux auxiliary current requirements.
21	RO	0b	Device Specific Initialization (DSI) Hardwired to 0 to indicate that special initialization of this device is NOT required before generic class device driver is to use it.
20	RO	0b	Auxiliary Power Source (APS) Hardwired to 0.
19	RO	0b	PME Clock (PMECLK) Hardwired to 0 to indicate this device does NOT support PMEB generation.
18:16	RO	011b	PCI PM CAP Version (PCIPMCV) Version - A value of 011b indicates that this function complies with revision 1.2 of the PCI Power Management Interface Specification.
15:8	RO	90h	Pointer to Next Capability (PNC) This field contains a pointer to the next item in the capabilities list. If MSICH (CAPL[0] @ 7Fh) is 0, then the next item in the capabilities list is the Message Signaled Interrupts (MSI) capability at 90h. If MSICH (CAPL[0] @ 7Fh) is 1, then the next item in the capabilities list is the PCI Express capability at A0h.
7:0	RO	01h	Capability ID (CID) Value of 01h identifies this linked list item (capability structure) as being for PCI Power Management registers.

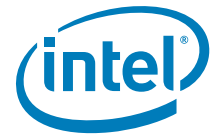

2.19.26 PM_CS6—Power Management Control/Status Register

B/D/F/Type:		0/6/0/PCI	
Address Offset:		84–87h	
Reset Value:		0000008h	
Access:		RO, RW, RW-S	
Bit	Attr	Reset Value	Description
31:16	RO	0000h	Reserved Not Applicable or Implemented. Hardwired to 0.
15	RO	0b	PME Status (PMESTS) Indicates that this device does not support PMEB generation from D3cold.
14:13	RO	00b	Data Scale (DSCALE) Indicates that this device does not support the power management data register.
12:9	RO	0h	Data Select (DSEL) Indicates that this device does not support the power management data register.
8	RW-S	0b	PME Enable (PMEE) Indicates that this device does not generate PMEB assertion from any D-state. 0 = PMEB generation not possible from any D State 1 = PMEB generation enabled from any D State The setting of this bit has no effect on hardware. See PM_CAP[15:11]
7:4	RO	0000b	Reserved
3	RO	1b	No Soft Reset (NSR) 1 = When set to 1 this bit indicates that the device is transitioning from D3hot to D0 because the power state commands do not perform a internal reset. Config context is preserved. Upon transition no additional operating system intervention is required to preserve configuration context beyond writing the power state bits. 0 = When clear the devices do not perform an internal reset upon transitioning from D3hot to D0 using software control of the power state bits. Regardless of this bit, the devices that transition from a D3hot to D0 by a system or bus segment reset will return to the device state D0 uninitialized with only PME context preserved if PME is supported and enabled.
2	RO	0b	Reserved
1:0	RW	00b	Power State (PS) This field indicates the current power state of this device and can be used to set the device into a new power state. If software attempts to write an unsupported state to this field, write operation must complete normally on the bus, but the data is discarded and no state change occurs. 00 = D0 01 = D1 (Not supported in this device.) 10 = D2 (Not supported in this device.) 11 = D3 Support of D3cold does not require any special action. While in the D3hot state, this device can only act as the target of PCI configuration transactions (for power management control). This device also cannot generate interrupts or respond to MMR cycles in the D3 state. The device must return to the D0 state in order to be fully-functional. When the Power State is other than D0, the bridge will Master Abort (that is, not claim) any downstream cycles (with exception of type 0 config cycles). Consequently, these unclaimed cycles will go down DMI and come back up as Unsupported Requests, which the MCH logs as Master Aborts in Device 0 PCISTS[13] There is no additional hardware functionality required to support these Power States.



2.19.27 SS_CAPID—Subsystem ID and Vendor ID Capabilities Register

This capability is used to uniquely identify the subsystem where the PCI device resides. Because this device is an integrated part of the system and not an add-in device, it is anticipated that this capability will never be used. However, it is necessary because Microsoft will test for its presence.

B/D/F/Type:		0/6/0/PCI	
Address Offset:		88–8Bh	
Reset Value:		0000800Dh	
Access:		RO	
Bit	Attr	Reset Value	Description
31:16	RO	0000h	Reserved
15:8	RO	80h	Pointer to Next Capability (PNC) This field contains a pointer to the next item in the capabilities list which is the PCI Power Management capability.
7:0	RO	0Dh	Capability ID (CID) Value of 0Dh identifies this linked list item (capability structure) as being for SSID/SSVID registers in a PCI-to-PCI Bridge.

2.19.28 SS—Subsystem ID and Subsystem Vendor ID Register

System BIOS can be used as the mechanism for loading the SSID/SVID values. These values must be preserved through power management transitions and a hardware reset.

B/D/F/Type:		0/6/0/PCI	
Address Offset:		8C–8Fh	
Reset Value:		00008086h	
Access:		RW-O	
Bit	Attr	Reset Value	Description
31:16	RW-O	0000h	Subsystem ID (SSID) This field identifies the particular subsystem and is assigned by the vendor.
15:0	RW-O	8086h	Subsystem Vendor ID (SSVID) This field identifies the manufacturer of the subsystem and is the same as the vendor ID which is assigned by the PCI Special Interest Group.

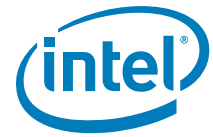

2.19.29 MSI_CAPID—Message Signaled Interrupts Capability ID Register

When a device supports MSI it can generate an interrupt request to the processor by writing a predefined data item (a message) to a predefined memory address.

The reporting of the existence of this capability can be disabled by setting MSICH (CAPL[0] @ 7Fh). In that case walking this linked list will skip this capability and instead go directly from the PCI PM capability to the PCI Express capability.

B/D/F/Type:		0/6/0/PCI	
Address Offset:		90–91h	
Reset Value:		A005h	
Access:		RO	
Bit	Attr	Reset Value	Description
15:8	RO	A0h	Pointer to Next Capability (PNC) This field contains a pointer to the next item in the capabilities list which is the PCI Express capability.
7:0	RO	05h	Capability ID (CID) Value of 05h identifies this linked list item (capability structure) as being for MSI registers.



2.19.30 MC—Message Control Register

System software can modify bits in this register, but the device is prohibited from doing so.

If the device writes the same message multiple times, only one of those messages is ensured to be serviced. If all of them must be serviced, the device must not generate the same message again until the driver services the earlier one.

B/D/F/Type: 0/6/0/PCI Address Offset: 92–93h Reset Value: 0000h Access: RO, RW			
Bit	Attr	Reset Value	Description
15:8	RO	00h	Reserved
7	RO	0b	64-bit Address Capable (64AC) Hardwired to 0 to indicate that the function does not implement the upper 32 bits of the Message Address register and is incapable of generating a 64-bit memory address.
6:4	RW	000b	Multiple Message Enable (MME) System software programs this field to indicate the actual number of messages allocated to this device. This number will be equal to or less than the number actually requested. The encoding is the same as for the MMC field below.
3:1	RO	000b	Multiple Message Capable (MMC) System software reads this field to determine the number of messages being requested by this device. 000 = 1 All of the following are reserved in this implementation: 001 = 2 010 = 4 011 = 8 100 = 16 101 = 32 110 = Reserved 111 = Reserved
0	RW	0b	MSI Enable (MSIEN) Controls the ability of this device to generate MSIs. 0 = MSI will not be generated. 1 = MSI will be generated when we receive PME or HotPlug messages. INTA will not be generated and INTA Status (PCISTS1[3]) will not be set.



2.19.31 MA—Message Address Register

B/D/F/Type:		0/6/0/PCI	
Address Offset:		94–97h	
Reset Value:		00000000h	
Access:		RW, RO	
Bit	Attr	Reset Value	Description
31:2	RW	00000000h	Message Address (MA) This field is used by system software to assign an MSI address to the device. The device handles an MSI by writing the padded contents of the MD register to this address.
1:0	RO	00b	Force DWord Align (FDWA) Hardwired to 0 so that addresses assigned by system software are always aligned on a dword address boundary.

2.19.32 MD—Message Data Register

B/D/F/Type:		0/6/0/PCI	
Address Offset:		98–99h	
Reset Value:		0000h	
Access:		RW	
Bit	Attr	Reset Value	Description
15:0	RW	0000h	Message Data (MD) Base message data pattern assigned by system software and used to handle an MSI from the device. When the device must generate an interrupt request, it writes a 32-bit value to the memory address specified in the MA register. The upper 16 bits are always set to 0. The lower 16 bits are supplied by this register.

2.19.33 PEG_CAPL—PCI Express-G Capability List Register

This register enumerates the PCI Express capability structure.

B/D/F/Type:		0/6/0/PCI	
Address Offset:		A0–A1h	
Reset Value:		0010h	
Access:		RO	
Bit	Attr	Reset Value	Description
15:8	RO	00h	Pointer to Next Capability (PNC) This value terminates the capabilities list. The Virtual Channel capability and any other PCI Express specific capabilities that are reported using this mechanism are in a separate capabilities list located entirely within PCI Express Extended Configuration Space.
7:0	RO	10h	Capability ID (CID) Identifies this linked list item (capability structure) as being for PCI Express registers.



2.19.34 PEG_CAP—PCI Express-G Capabilities Register

This register indicates PCI Express device capabilities.

B/D/F/Type:		0/6/0/PCI	
Address Offset:		A2–A3h	
Reset Value:		0142h	
Access:		RO, RW-O	
Bit	Attr	Reset Value	Description
15	RO	0b	Reserved
14	RO	0b	Reserved: Reserved for TCS Routing Supported.
13:9	RO	00h	Interrupt Message Number (IMN) Not Applicable or Implemented. Hardwired to 0.
8	RW-O	1b	Slot Implemented (SI) 0 = The PCI Express Link associated with this port is connected to an integrated component or is disabled. 1 = The PCI Express Link associated with this port is connected to a slot. BIOS Requirement: This field must be initialized appropriately if a slot connection is not implemented.
7:4	RO	4h	Device/Port Type (DPT) Hardwired to 4h to indicate root port of PCI Express Root Complex.
3:0	RO	2h	PCI Express Capability Version (PCIECV) Hardwired to 2h to indicate compliance to the PCI Express Capabilities Register Expansion ECN.

2.19.35 DCAP—Device Capabilities Register

This register indicates PCI Express device capabilities.

B/D/F/Type:		0/6/0/PCI	
Address Offset:		A4–A7h	
Reset Value:		00008000h	
Access:		RO	
Bit	Attr	Reset Value	Description
31:16	RO	0000h	Reserved Not Applicable or Implemented. Hardwired to 0.
15	RO	1b	Role Based Error Reporting (RBER) This bit indicates that this device implements the functionality defined in the Error Reporting ECN as required by the PCI Express 1.1 spec.
14:6	RO	000h	Reserved Not Applicable or Implemented. Hardwired to 0.
5	RO	0b	Extended Tag Field Supported (ETFS) Hardwired to indicate support for 5-bit Tags as a Requestor.
4:3	RO	00b	Phantom Functions Supported (PFS) Not Applicable or Implemented. Hardwired to 0.
2:0	RO	000b	Max Payload Size (MPS) Hardwired to indicate 128B max supported payload for Transaction Layer Packets (TLP).



2.19.36 DCTL—Device Control Register

This register provides control for PCI Express device specific capabilities.

The error reporting enable bits are in reference to errors detected by this device, not error messages received across the link. The reporting of error messages (ERR_CORR, ERR_NONFATAL, ERR_FATAL) received by Root Port is controlled exclusively by Root Port Command Register.

B/D/F/Type:		0/6/0/PCI	
Address Offset:		A8–A9h	
Reset Value:		0000h	
Access:		RW, RO	
Bit	Attr	Reset Value	Description
15	RO	0h	Reserved
14:12	RO	000b	Reserved for Max Read Request Size (MRRS)
11	RO	0b	Reserved for Enable No Snoop
10	RO	0b	Reserved
9	RO	0b	Reserved
8	RO	0b	Reserved
7:5	RW	000b	Max Payload Size (MPS) 000 = 128B maximum supported payload for Transaction Layer Packets (TLP). As a receiver, the Device must handle TLPs as large as the set value; as transmitter, the Device must not generate TLPs exceeding the set value. All other encodings are reserved. Hardware will actually ignore this field. It is writeable only to support compliance testing.
4	RO	0b	Reserved for Enable Relaxed Ordering
3	RW	0b	Unsupported Request Reporting Enable (URRE) When set, this bit allows signaling ERR_NONFATAL, ERR_FATAL, or ERR_CORR to the Root Control register when detecting an unmasked Unsupported Request (UR). An ERR_CORR is signaled when an unmasked Advisory Non-Fatal UR is received. An ERR_FATAL or ERR_NONFATAL is sent to the Root Control register when an uncorrectable non-Advisory UR is received with the severity bit set in the Uncorrectable Error Severity register.
2	RW	0b	Fatal Error Reporting Enable (FERE) When set, this bit enables signaling of ERR_FATAL to the Root Control register due to internally detected errors or error messages received across the link. Other bits also control the full scope of related error reporting.
1	RW	0b	Non-Fatal Error Reporting Enable (NERE) When set, this bit enables signaling of ERR_NONFATAL to the Root Control register due to internally detected errors or error messages received across the link. Other bits also control the full scope of related error reporting.
0	RW	0b	Correctable Error Reporting Enable (CERE) When set, this bit enables signaling of ERR_CORR to the Root Control register due to internally detected errors or error messages received across the link. Other bits also control the full scope of related error reporting.



2.19.37 DSTS—Device Status Register

This register reflects status corresponding to controls in the Device Control register. The error reporting bits are in reference to errors detected by this device, not errors messages received across the link.

B/D/F/Type:		0/6/0/PCI	
Address Offset:		AA–ABh	
Reset Value:		0000h	
Access:		RO, RW1C	
Bit	Attr	Reset Value	Description
15:6	RO	000h	Reserved and Zero For future R/WC/S implementations; software must use 0 for writes to bits.
5	RO	0b	Transactions Pending (TP) 0 = All pending transactions (including completions for any outstanding non-posted requests on any used virtual channel) have been completed. 1 = Indicates that the device has transaction(s) pending (including completions for any outstanding non-posted requests for all used Traffic Classes).
4	RO	0b	Reserved
3	RW1C	0b	Unsupported Request Detected (URD) When set, this bit indicates that the Device received an Unsupported Request. Errors are logged in this register regardless of whether error reporting is enabled or not in the Device Control Register. Additionally, the Non-Fatal Error Detected bit or the Fatal Error Detected bit is set according to the setting of the Unsupported Request Error Severity bit. In production systems setting the Fatal Error Detected bit is not an option as support for AER will not be reported.
2	RW1C	0b	Fatal Error Detected (FED) When set, this bit indicates that fatal error(s) were detected. Errors are logged in this register regardless of whether error reporting is enabled or not in the Device Control register. When Advanced Error Handling is enabled, errors are logged in this register regardless of the settings of the uncorrectable error mask register.
1	RW1C	0b	Non-Fatal Error Detected (NFED) When set, this bit indicates that non-fatal error(s) were detected. Errors are logged in this register regardless of whether error reporting is enabled or not in the Device Control register. When Advanced Error Handling is enabled, errors are logged in this register regardless of the settings of the uncorrectable error mask register.
0	RW1C	0b	Correctable Error Detected (CED) When set, this bit indicates that correctable error(s) were detected. Errors are logged in this register regardless of whether error reporting is enabled or not in the Device Control register. When Advanced Error Handling is enabled, errors are logged in this register regardless of the settings of the correctable error mask register.



2.19.38 LCAP—Link Capabilities Register

This register indicates PCI Express device specific capabilities.

B/D/F/Type:		0/6/0/PCI	
Address Offset:		AC-AFh	
Reset Value:		03214C82h	
Access:		RO, RW-O	
Bit	Attr	Reset Value	Description
31:24	RO	03h	Port Number (PN) This field indicates the PCI Express port number for the given PCI Express link. Matches the value in Element Self Description[31:24].
23:22	RO	00b	Reserved
21	RO	1b	Link Bandwidth Notification Capability (LBNC) A value of 1b indicates support for the Link Bandwidth Notification status and interrupt mechanisms. This capability is required for all Root Ports and Switch downstream ports supporting Links wider than x1 and/or multiple Link speeds. This field is not applicable and is reserved for Endpoint devices, PCI Express to PCI/PCI-X bridges, and Upstream Ports of Switches. Devices that do not implement the Link Bandwidth Notification capability must hardwire this bit to 0b.
20	RO	0b	Data Link Layer Link Active Reporting Capable (DLLARC) For a Downstream Port, this bit must be set to 1b if the component supports the optional capability of reporting the DL_Active state of the Data Link Control and Management State Machine. For a hot-plug capable Downstream Port (as indicated by the Hot-Plug Capable field of the Slot Capabilities register), this bit must be set to 1b. For Upstream Ports and components that do not support this optional capability, this bit must be hardwired to 0b.
19	RO	0b	Surprise Down Error Reporting Capable (SDERC) For a Downstream Port, this bit must be set to 1b if the component supports the optional capability of detecting and reporting a Surprise Down error condition. For Upstream Ports and components that do not support this optional capability, this bit must be hardwired to 0b.
18	RO	0b	Clock Power Management (CPM) A value of 1b in this bit indicates that the component tolerates the removal of any reference clock(s) when the link is in the L1 and L2/3 Ready link states. A value of 0b indicates the component does not have this capability and that reference clock(s) must not be removed in these link states. This capability is applicable only in form factors that support "clock request" (CLKREQ#) capability. For a multi-function device, each function indicates its capability independently. Power Management configuration software must only permit reference clock removal if all functions of the multifunction device indicate a 1b in this bit.
17:15	RW-O	010b	L1 Exit Latency (L1ELAT) Indicates the length of time this Port requires to complete the transition from L1 to L0. The value 010 b indicates the range of 2 us to less than 4 us. BIOS Requirement: If this field is required to be any value other than the default, BIOS must initialize it accordingly. Both bytes of this register that contain a portion of this field must be written simultaneously in order to prevent an intermediate (and undesired) value from ever existing.



B/D/F/Type:		O/6/O/PCI	
Address Offset:		AC-AFh	
Reset Value:		03214C82h	
Access:		RO, RW-O	
Bit	Attr	Reset Value	Description
14:12	RO	100b	<p>LOs Exit Latency (LOSELAT) This field indicates the length of time this Port requires to complete the transition from LOs to L0. 000 =Less than 64 ns 001 =64 ns to less than 128 ns 010 =128 ns to less than 256 ns 011 =256 ns to less than 512 ns 100 =512 ns to less than 1 us 101 =1 us to less than 2 us 110 =2 us – 4 us 111 =More than 4 us The actual value of this field depends on the common Clock Configuration bit (LCTL[6]) and the Common and Non-Common clock LOs Exit Latency values in PEGLOSLAT (Offset 22Ch)</p>
11:10	RW-O	11b	<p>Active State Link PM Support (ASLPMS) This field indicates support for ASPM L0s and L1.</p>
9:4	RW-O	08h	<p>Max Link Width (MLW) This field indicates the maximum number of lanes supported for this link.</p>
3:0	RW-O	0010b	<p>Max Link Speed (MLS) This field indicates the supported Link speed(s) of the associated Port. Defined encodings are: 0001b =2.5GT/s Link speed supported 0010b =5.0GT/s and 2.5GT/s Link speeds supported All other encodings are reserved.</p>



2.19.39 LCTL—Link Control Register

This register allows control of PCI Express link.

B/D/F/Type:		0/6/0/PCI	
Address Offset:		B0–B1h	
Reset Value:		0000h	
Access:		RW, RO, RW-SC	
Bit	Attr	Reset Value	Description
15:12	RO	0000b	Reserved
11	RW	0b	<p>Link Autonomous Bandwidth Interrupt Enable (LABIE) When Set, this bit enables the generation of an interrupt to indicate that the Link Autonomous Bandwidth Status bit has been Set. This bit is not applicable and is reserved for Endpoint devices, PCI Express to PCI/PCI-X bridges, and Upstream Ports of Switches. Devices that do not implement the Link Bandwidth Notification capability must hardwire this bit to 0b.</p>
10	RW	0b	<p>Link Bandwidth Management Interrupt Enable (LBMIE) When Set, this bit enables the generation of an interrupt to indicate that the Link Bandwidth Management Status bit has been Set. This bit is not applicable and is reserved for Endpoint devices, PCI Express to PCI/PCI-X bridges, and Upstream Ports of Switches.</p>
9	RW	0b	<p>Hardware Autonomous Width Disable (HAWD) When Set, this bit disables hardware from changing the Link width for reasons other than attempting to correct unreliable Link operation by reducing Link width. Devices that do not implement the ability autonomously to change Link width are permitted to hardwire this bit to 0b.</p>
8	RO	0b	<p>Enable Clock Power Management (ECPM) Applicable only for form factors that support a "Clock Request" (CLKREQ#) mechanism, this enable functions as follows 0 = Clock power management is disabled and device must hold CLKREQ# signal low 1 = When this bit is set to 1 the device is permitted to use CLKREQ# signal to power manage link clock according to protocol defined in appropriate form factor specification. Components that do not support Clock Power Management (as indicated by a 0b value in the Clock Power Management bit of the Link Capabilities Register) must hardwire this bit to 0b.</p>
7	RW	0b	<p>Extended Synch (ES) 0 = Standard Fast Training Sequence (FTS). 1 = Forces the transmission of additional ordered sets when exiting the L0s state and when in the Recovery state. This mode provides external devices (such as, logic analyzers) monitoring the Link time to achieve bit and symbol lock before the link enters L0 and resumes communication. This is a test mode only and may cause other undesired side effects such as buffer overflows or underruns.</p>
6	RW	0b	<p>Common Clock Configuration (CCC) 0 = Indicates that this component and the component at the opposite end of this Link are operating with asynchronous reference clock. 1 = Indicates that this component and the component at the opposite end of this Link are operating with a distributed common reference clock. The state of this bit affects the L0s Exit Latency reported in LCAP[14:12] and the N_FTS value advertised during link training. See PEGLOSLAT at offset 22Ch.</p>



B/D/F/Type:		0/6/0/PCI	
Address Offset:		B0–B1h	
Reset Value:		0000h	
Access:		RW, RO, RW-SC	
Bit	Attr	Reset Value	Description
5	RW-SC	0b	<p>Retrain Link (RL) 0 = Normal operation. 1 = Full Link retraining is initiated by directing the Physical Layer LTSSM from L0, L0s, or L1 states to the Recovery state.</p> <p>This bit always returns 0 when read. This bit is cleared automatically (no need to write a 0). It is permitted to write 1b to this bit while simultaneously writing modified values to other fields in this register. If the LTSSM is not already in Recovery or Configuration, the resulting Link training must use the modified values. If the LTSSM is already in Recovery or Configuration, the modified values are not required to affect the Link training that's already in progress.</p>
4	RW	0b	<p>Link Disable (LD) 0 = Normal operation 1 = Link is disabled. Forces the LTSSM to transition to the Disabled state (using Recovery) from L0, L0s, or L1 states. Link retraining happens automatically on 0 to 1 transition, just like when coming out of reset.</p> <p>Writes to this bit are immediately reflected in the value read from the bit, regardless of actual Link state.</p>
3	RO	0b	<p>Read Completion Boundary (RCB) Hardwired to 0 to indicate 64 byte.</p>
2	RO	0b	<p>Reserved</p>
1:0	RW	00b	<p>Active State PM (ASPM) This bit controls the level of active state power management supported on the given link. 00 = Disabled 01 = L0s Entry Supported 10 = L1 Entry Enabled 11 = L0s and L1 Entry Supported</p> <p>Note: "L0s Entry Enabled" indicates the Transmitter entering L0s is supported. The Receiver must be capable of entering L0s even when the field is disabled (00b).</p> <p>ASPM L1 must be enabled by software in the Upstream component on a Link prior to enabling ASPM L1 in the Downstream component on that Link. When disabling ASPM L1, software must disable ASPM L1 in the Downstream component on a Link prior to disabling ASPM L1 in the Upstream component on that Link. ASPM L1 must only be enabled on the Downstream component if both components on a Link support ASPM L1.</p>

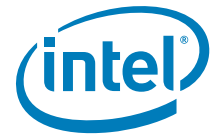

2.19.40 LSTS—Link Status Register

This register indicates PCI Express link status.

B/D/F/Type:		0/6/0/PCI	
Address Offset:		B2–B3h	
Reset Value:		1000h	
Access:		RO, RW1C	
Bit	Attr	Reset Value	Description
15	RW1C	0b	<p>Link Autonomous Bandwidth Status (LABWS)</p> <p>This bit is set to 1b by hardware to indicate that hardware has autonomously changed link speed or width, without the port transitioning through DL_Down status, for reasons other than to attempt to correct unreliable link operation. This bit must be set if the Physical Layer reports a speed or width change was initiated by the downstream component that was indicated as an autonomous change.</p>
14	RW1C	0b	<p>Link Bandwidth Management Status (LBWMS)</p> <p>This bit is set to 1b by hardware to indicate that either of the following has occurred without the port transitioning through DL_Down status: A link retraining initiated by a write of 1b to the Retrain Link bit has completed.</p> <p>Note: This bit is Set following any write of 1b to the Retrain Link bit, including when the Link is in the process of retraining for some other reason. Hardware has autonomously changed link speed or width to attempt to correct unreliable link operation, either through an LTSSM time-out or a higher level process.</p> <p>This bit must be set if the Physical Layer reports a speed or width change was initiated by the downstream component that was not indicated as an autonomous change.</p>
13	RO	0b	<p>Data Link Layer Link Active (Optional) (DLLLA)</p> <p>This bit indicates the status of the Data Link Control and Management State Machine. It returns a 1b to indicate the DL_Active state, 0b otherwise. This bit must be implemented if the corresponding Data Link Layer Active Capability bit is implemented. Otherwise, this bit must be hardwired to 0b.</p>
12	RO	1b	<p>Slot Clock Configuration (SCC)</p> <p>0 = The device uses an independent clock irrespective of the presence of a reference on the connector. 1 = The device uses the same physical reference clock that the platform provides on the connector.</p>
11	RO	0b	<p>Link Training (LTRN)</p> <p>This bit indicates that the Physical Layer LTSSM is in the Configuration or Recovery state, or that 1b was written to the Retrain Link bit but Link training has not yet begun. Hardware clears this bit when the LTSSM exits the Configuration/Recovery state once Link training is complete.</p>
10	RO	0b	<p>Undefined (Reserved)</p> <p>The value read from this bit is undefined. In previous versions of this specification, this bit was used to indicate a Link Training Error. System software must ignore the value read from this bit. System software is permitted to write any value to this bit.</p>
9:4	RO	00h	<p>Negotiated Link Width (NLW)</p> <p>This field indicates negotiated link width. This field is valid only when the link is in the L0, L0s, or L1 states (after link width negotiation is successfully completed).</p> <p>00h = Reserved 01h = X1 02h = X2 04h = X4 08h = X8 10h = X16 All other encodings are reserved.</p>



B/D/F/Type:		0/6/0/PCI	
Address Offset:		B2–B3h	
Reset Value:		1000h	
Access:		RO, RW1C	
Bit	Attr	Reset Value	Description
3:0	RO	0h	Current Link Speed (CLS) This field indicates the negotiated Link speed of the given PCI Express Link. Defined encodings are: 0001b = 2.5 GT/s PCI Express Link 0010b = 5.0 GT/s PCI Express Link All other encodings are reserved. The value in this field is undefined when the Link is not up

2.19.41 SLOTCAP—Slot Capabilities Register

Note: Hot Plug is not supported on the platform.

B/D/F/Type:		0/6/0/PCI	
Address Offset:		B4–B7h	
Reset Value:		00040000h	
Access:		RW-O, RO	
Bit	Attr	Reset Value	Description
31:19	RW-O	0000h	Physical Slot Number (PSN) This field indicates the physical slot number attached to this Port. BIOS Requirement: This field must be initialized by BIOS to a value that assigns a slot number that is globally unique within the chassis.
18	RW-O	1b	No Command Completed Support (NCCS) When set to 1, this bit indicates that this slot does not generate software notification when an issued command is completed by the Hot-Plug Controller. This bit is only permitted to be set to 1b if the hotplug capable port is able to accept writes to all fields of the Slot Control register without delay between successive writes.
17	RO	0b	Reserved for Electromechanical Interlock Present (EIP) When set to 1, this bit indicates that an Electromechanical Interlock is implemented on the chassis for this slot.
16:15	RW-O	00b	Slot Power Limit Scale (SPLS) This field specifies the scale used for the Slot Power Limit Value. 00 = 1.0x 01 = 0.1x 10 = 0.01x 11 = 0.001x If this field is written, the link sends a Set_Slot_Power_Limit message.
14:7	RW-O	00h	Slot Power Limit Value (SPLV) In combination with the Slot Power Limit Scale value, specifies the upper limit on power supplied by slot. Power limit (in Watts) is calculated by multiplying the value in this field by the value in the Slot Power Limit Scale field. If this field is written, the link sends a Set_Slot_Power_Limit message.
6	RO	0b	Reserved for Hot-plug Capable (HPC) When set to 1, this bit indicates that this slot is capable of supporting hot-lug operations.



B/D/F/Type: 0/6/0/PCI Address Offset: B4–B7h Reset Value: 00040000h Access: RW-O, RO			
Bit	Attr	Reset Value	Description
5	RO	0b	Reserved for Hot-plug Surprise (HPS) When set to 1, this bit indicates that an adapter present in this slot might be removed from the system without any prior notification. This is a form factor specific capability. This bit is an indication to the operating system to allow for such removal without impacting continued software operation.
4	RO	0b	Reserved for Power Indicator Present (PIP) When set to 1, this bit indicates that a Power Indicator is electrically controlled by the chassis for this slot.
3	RO	0b	Reserved for Attention Indicator Present (AIP) When set to 1, this bit indicates that an Attention Indicator is electrically controlled by the chassis.
2	RO	0b	Reserved for MRL Sensor Present (MSP) When set to 1, this bit indicates that an MRL Sensor is implemented on the chassis for this slot.
1	RO	0b	Reserved for Power Controller Present (PCP) When set to 1, this bit indicates that a software programmable Power Controller is implemented for this slot/adapter (depending on form factor).
0	RO	0b	Reserved for Attention Button Present (ABP) When set to 1, this bit indicates that an Attention Button for this slot is electrically controlled by the chassis.



2.19.42 SLOTCTL—Slot Control Register

Note: Hot Plug is not supported on the platforms.

B/D/F/Type:		0/6/0/PCI	
Address Offset:		B8–B9h	
Reset Value:		0000h	
Access:		RO, RW	
Bit	Attr	Reset Value	Description
15:13	RO	000b	Reserved
12	RO	0b	<p>Reserved for Data Link Layer State Changed Enable (DLLSCE)</p> <p>If the Data Link Layer Link Active capability is implemented, when set to 1b, this field enables software notification when Data Link Layer Link Active field is changed.</p> <p>If the Data Link Layer Link Active capability is not implemented, this bit is permitted to be read-only with a value of 0b.</p>
11	RO	0b	<p>Reserved for Electromechanical Interlock Control (EIC)</p> <p>If an Electromechanical Interlock is implemented, a write of 1b to this field causes the state of the interlock to toggle. A write of 0b to this field has no effect. A read to this register always returns a 0.</p>
10	RO	0b	<p>Reserved for Power Controller Control (PCC)</p> <p>If a Power Controller is implemented, this field when written sets the power state of the slot per the defined encodings. Reads of this field must reflect the value from the latest write, even if the corresponding hotplug command is not complete, unless software issues a write without waiting for the previous command to complete in which case the read value is undefined.</p> <p>Depending on the form factor, the power is turned on/off either to the slot or within the adapter. Note that in some cases the power controller may autonomously remove slot power or not respond to a power-up request based on a detected fault condition, independent of the Power Controller Control setting.</p> <p>The defined encodings are: 0b = Power On 1b = Power Off</p> <p>If the Power Controller Implemented field in the Slot Capabilities register is set to 0b, then writes to this field have no effect and the read value of this field is undefined.</p>
9:8	RO	00b	<p>Reserved Power Indicator Control (PIC)</p> <p>If a Power Indicator is implemented, writes to this field set the Power Indicator to the written state. Reads of this field must reflect the value from the latest write, even if the corresponding hot-plug command is not complete, unless software issues a write without waiting for the previous command to complete in which case the read value is undefined.</p> <p>00 = Reserved 01 = On 10 = Blink 11 = Off</p> <p>If the Power Indicator Present bit in the Slot Capabilities register is 0b, this field is permitted to be read-only with a value of 00b.</p>

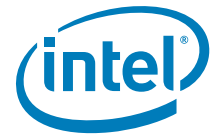

B/D/F/Type: 0/6/0/PCI Address Offset: B8–B9h Reset Value: 0000h Access: RO, RW			
Bit	Attr	Reset Value	Description
7:6	RO	00b	Reserved for Attention Indicator Control (AIC) If an Attention Indicator is implemented, writes to this field set the Attention Indicator to the written state. Reads of this field must reflect the value from the latest write, even if the corresponding hot-plug command is not complete, unless software issues a write without waiting for the previous command to complete in which case the read value is undefined. If the indicator is electrically controlled by chassis, the indicator is controlled directly by the downstream port through implementation specific mechanisms. 00 = Reserved 01 = On 10 = Blink 11 = Off If the Attention Indicator Present bit in the Slot Capabilities register is 0b, this field is permitted to be read only with a value of 00b.
5	RO	0b	Reserved for Hot-plug Interrupt Enable (HPIE) When set to 1, this bit enables generation of an interrupt on enabled hot-plug events Reset Value of this field is 0b. If the Hot Plug Capable field in the Slot Capabilities register is set to 0b, this bit is permitted to be read-only with a value of 0b.
4	RO	0b	Reserved for Command Completed Interrupt Enable (CCI) If Command Completed notification is supported (as indicated by No Command Completed Support field of Slot Capabilities Register), when set to 1b, this bit enables software notification when a hot-plug command is completed by the Hot-Plug Controller. Reset Value of this field is 0b. If Command Completed notification is not supported, this bit must be hardwired to 0b.
3	RW	0b	Presence Detect Changed Enable (PDCE) When set to 1, this bit enables software notification on a presence detect changed event.
2	RO	0b	Reserved for MRL Sensor Changed Enable (MSCE) When set to 1, this bit enables software notification on a MRL sensor changed event. Reset Value of this field is 0b. If the MRL Sensor Present field in the Slot Capabilities register is set to 0b, this bit is permitted to be read-only with a value of 0b.
1	RO	0b	Reserved for Power Fault Detected Enable (PFDE) When set to 1, this bit enables software notification on a power fault event. Reset Value of this field is 0b. If Power Fault detection is not supported, this bit is permitted to be read-only with a value of 0b.
0	RO	0b	Reserved for Attention Button Pressed Enable (ABPE) When set to 1, this bit enables software notification on an attention button pressed event.



2.19.43 SLOTSTS—Slot Status Register

Note: Hot Plug is not supported on the platform.

B/D/F/Type:		0/6/0/PCI	
Address Offset:		BA–BBh	
Reset Value:		0000h	
Access:		RO, RW1C	
Bit	Attr	Reset Value	Description
15:9	RO	0000000b	Reserved. MBZ For future R/WC/S implementations; software must use 0 for writes to bits.
8	RO	0b	Reserved for Data Link Layer State Changed (DLLSC) This bit is set when the value reported in the Data Link Layer Link Active field of the Link Status register is changed. In response to a Data Link Layer State Changed event, software must read the Data Link Layer Link Active field of the Link Status register to determine if the link is active before initiating configuration cycles to the hot plugged device.
7	RO	0b	Reserved for Electromechanical Interlock Status (EIS) If an Electromechanical Interlock is implemented, this bit indicates the current status of the Electromechanical Interlock. 0 = Electromechanical Interlock Disengaged 1 = Electromechanical Interlock Engaged
6	RO	0b	Presence Detect State (PDS) This bit indicates the presence of an adapter in the slot, reflected by the logical "OR" of the Physical Layer in-band presence detect mechanism and, if present, any out-of-band presence detect mechanism defined for the slot's corresponding form factor. Note that the in-band presence detect mechanism requires that power be applied to an adapter for its presence to be detected. Consequently, form factors that require a power controller for hot-plug must implement a physical pin presence detect mechanism. 0 = Slot Empty 1 = Card Present in slot This register must be implemented on all Downstream Ports that implement slots. For Downstream Ports not connected to slots (where the Slot Implemented bit of the PCI Express Capabilities Register is 0b), this bit must return 1b.
5	RO	0b	Reserved for MRL Sensor State (MSS) This register reports the status of the MRL sensor if it is implemented. 0 = MRL Closed 1 = MRL Open
4	RO	0b	Reserved for Command Completed (CC) If Command Completed notification is supported (as indicated by No Command Completed Support field of Slot Capabilities Register), this bit is set when a hot-plug command has completed and the Hot-Plug Controller is ready to accept a subsequent command. The Command Completed status bit is set as an indication to host software that the Hot-Plug Controller has processed the previous command and is ready to receive the next command; it provides no assurance that the action corresponding to the command is complete. If Command Completed notification is not supported, this bit must be hardwired to 0b.
3	RW1C	0b	Presence Detect Changed (PDC) A pulse indication that the inband presence detect state has changed This bit is set when the value reported in Presence Detect State is changed.



B/D/F/Type: Address Offset: Reset Value: Access:		0/6/0/PCI BA–BBh 0000h RO, RW1C	
Bit	Attr	Reset Value	Description
2	RO	0b	Reserved for MRL Sensor Changed (MSC) If an MRL sensor is implemented, this bit is set when a MRL Sensor state change is detected. If an MRL sensor is not implemented, this bit must not be set.
1	RO	0b	Reserved for Power Fault Detected (PFD) If a Power Controller that supports power fault detection is implemented, this bit is set when the Power Controller detects a power fault at this slot. Note that, depending on hardware capability, it is possible that a power fault can be detected at any time, independent of the Power Controller Control setting or the occupancy of the slot. If power fault detection is not supported, this bit must not be set.
0	RO	0b	Reserved for Attention Button Pressed (ABP) If an Attention Button is implemented, this bit is set when the attention button is pressed. If an Attention Button is not supported, this bit must not be set.



2.19.44 RCTL—Root Control Register

This register allows control of PCI Express Root Complex specific parameters. The system error control bits in this register determine if corresponding SERRs are generated when our device detects an error (reported in this device's Device Status register) or when an error message is received across the link. Reporting of SERR as controlled by these bits takes precedence over the SERR Enable in the PCI Command Register.

B/D/F/Type:		0/6/0/PCI	
Address Offset:		BC–BDh	
Reset Value:		0000h	
Access:		RO, RW	
Bit	Attr	Reset Value	Description
15:5	RO	000h	Reserved
4	RO	0b	Reserved for CRS Software Visibility Enable (CSVE) This bit, when set, enables the Root Port to return Configuration Request Retry Status (CRS) Completion Status to software. Root Ports that do not implement this capability must hardwire this bit to 0b.
3	RW	0b	PME Interrupt Enable (PMEIE) 0 = No interrupts are generated as a result of receiving PME messages. 1 = Enables interrupt generation upon receipt of a PME message as reflected in the PME Status bit of the Root Status Register. A PME interrupt is also generated if the PME Status bit of the Root Status Register is set when this bit is set from a cleared state.
2	RW	0b	System Error on Fatal Error Enable (SEFEE) This bit controls the Root Complex's response to fatal errors. 0 = No SERR generated on receipt of fatal error. 1 = Indicates that a SERR should be generated if a fatal error is reported by any of the devices in the hierarchy associated with this Root Port, or by the Root Port itself.
1	RW	0b	System Error on Non-Fatal Uncorrectable Error Enable (SENFUEE) This bit controls the Root Complex's response to non-fatal errors. 0 = No SERR generated on receipt of non-fatal error. 1 = Indicates that a SERR should be generated if a non-fatal error is reported by any of the devices in the hierarchy associated with this Root Port, or by the Root Port itself.
0	RW	0b	System Error on Correctable Error Enable (SECEE) This bit controls the Root Complex's response to correctable errors. 0 = No SERR generated on receipt of correctable error. 1 = Indicates that a SERR should be generated if a correctable error is reported by any of the devices in the hierarchy associated with this Root Port, or by the Root Port itself.



2.19.45 RSTS—Root Status

This register provides information about PCI Express Root Complex specific parameters.

B/D/F/Type:		0/6/0/PCI	
Address Offset:		C0–C3h	
Reset Value:		00000000h	
Access:		RO, RW1C	
Bit	Attr	Reset Value	Description
31:18	RO	0000h	Reserved: MBZ For future R/WC/S implementations; software must use 0 for writes to bits.
17	RO	0b	PME Pending (PMEP) This bit indicates that another PME is pending when the PME Status bit is set. When the PME Status bit is cleared by software; the PME is delivered by hardware by setting the PME Status bit again and updating the Requestor ID appropriately. The PME pending bit is cleared by hardware if no more PMEs are pending.
16	RW1C	0b	PME Status (PMES) This bit indicates that PME was asserted by the requestor ID indicated in the PME Requestor ID field. Subsequent PMEs are kept pending until the status register is cleared by writing a 1 to this field.
15:0	RO	0000h	PME Requestor ID (PMERID) This bit indicates the PCI requestor ID of the last PME requestor.

2.19.46 PEGLC—PCI Express-G Legacy Control Register

This register controls functionality that is needed by Legacy (non-PCI Express aware) OSs during run time.

B/D/F/Type:		0/6/0/PCI	
Address Offset:		EC–EFh	
Reset Value:		0000_0000h	
Access:		RO, RW	
Bit	Attr	Reset Value	Description
31:3	RO	00..00b	Reserved
2	RW	0b	PME GPE Enable (PMEGPE) 0 = Do not generate GPE PME message when PME is received. 1 = Generate a GPE PME message when PME is received (Assert_PMEGPE and Deassert_PMEGPE messages on DMI). This enables the MCH to support PMEs on the PEG port under legacy OSs.
1	RW	0b	Hot-Plug GPE Enable (HPGPE) 0 = Do not generate GPE Hot-Plug message when Hot-Plug event is received. 1 = Generate a GPE Hot-Plug message when Hot-Plug Event is received (Assert_HPGPE and Deassert_HPGPE messages on DMI). This enables the MCH to support Hot-Plug on the PEG port under legacy OSs.
0	RW	0b	General Message GPE Enable (GENGPE) 0 = Do not forward received GPE assert/de-assert messages. 1 = Forward received GPE assert/de-assert messages. These general GPE message can be received using the PEG port from an external Intel device (that is, PxH) and will be subsequently forwarded to the PCH (using Assert_GPE and Deassert_GPE messages on DMI). For example, PxH might send this message if a PCI Express device is hot plugged into a PxH downstream port.



2.20 Device 6 Extended Configuration Registers

Note: Device 6 is not supported on all SKUs.

Table 2-15. Device 6 Extended Configuration Register Address Map

Address Offset	Register Symbol	Register Name	Reset Value	Access
104–107h	PVCCAP1	Port VC Capability Register 1	00000000h	RO
108–10Bh	PVCCAP2	Port VC Capability Register 2	00000000h	RO
10C–10Dh	PVCCTL	Port VC Control	0000h	RO, RW
110–113h	VCORCAP	VC0 Resource Capability	00000001h	RO
114–117h	VCORCTL	VC0 Resource Control	800000FFh	RO, RW
11A–11Bh	VCORSTS	VC0 Resource Status	0002h	RO
140–143h	RCLDECH	Root Complex Link Declaration Enhanced	00010005h	RO

2.20.1 PVCCAP1—Port VC Capability Register 1

This register describes the configuration of PCI Express Virtual Channels associated with this port.

B/D/F/Type:		0/6/0/MMR	
Address Offset:		104–107h	
Reset Value:		0000_0000h	
Access:		RO	
Bit	Attr	Reset Value	Description
31:12	RO	00000h	Reserved
11:10	RO	00b	Reserved: Reserved for Port Arbitration Table Entry Size
9:8	RO	00b	Reserved: Reserved for Reference Clock
7	RO	0b	Reserved
6:4	RO	000b	Low Priority Extended VC Count (LPEVCC) Indicates the number of (extended) Virtual Channels in addition to the default VC belonging to the low-priority VC (LPVC) group that has the lowest priority with respect to other VC resources in a strict-priority VC Arbitration. The value of 0 in this field implies strict VC arbitration.
3	RO	0b	Reserved
2:0	RO	000b	Extended VC Count (EVCC) Indicates the number of (extended) Virtual Channels in addition to the default VC supported by the device.

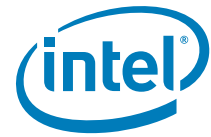

2.20.2 PVCCAP2—Port VC Capability Register 2

This register describes the configuration of PCI Express Virtual Channels associated with this port.

B/D/F/Type:		0/6/0/MMR	
Address Offset:		108–10Bh	
Reset Value:		0000_0000h	
Access:		RO	
Bit	Attr	Reset Value	Description
31:24	RO	00h	VC Arbitration Table Offset (VCATO) This field indicates the location of the VC Arbitration Table. This field contains the zero-based offset of the table in DQWORDS (16 bytes) from the base address of the Virtual Channel Capability Structure. A value of 0 indicates that the table is not present (due to fixed VC priority).
23:8	RO	0000h	Reserved
7:0	RO	00h	Reserved for VC Arbitration Capability (VCAC)

2.20.3 PVCCTL—Port VC Control Register

B/D/F/Type:		0/6/0/MMR	
Address Offset:		10C–10Dh	
Reset Value:		0000h	
Access:		RO, RW	
Bit	Attr	Reset Value	Description
15:4	RO	000h	Reserved
3:1	RW	000b	VC Arbitration Select (VCAS) This field will be programmed by software to the only possible value as indicated in the VC Arbitration Capability field. Since there is no other VC supported than the default, this field is reserved.
0	RO	0b	Reserved for Load VC Arbitration Table Used for software to update the VC Arbitration Table when VC arbitration uses the VC Arbitration Table. As a VC Arbitration Table is never used by this component, this field will never be used.



2.20.4 VCORCAP—VCO Resource Capability Register

B/D/F/Type:		0/6/0/MMR	
Address Offset:		110–113h	
Reset Value:		0000_0001h	
Access:		RO	
Bit	Attr	Reset Value	Description
31:24	RO	00h	Reserved for Port Arbitration Table Offset
23	RO	0b	Reserved
22:16	RO	00h	Reserved for Maximum Time Slots
15	RO	0b	Reject Snoop Transactions (RSNPT) 0 = Transactions with or without the No Snoop bit set within the TLP header are allowed on this VC. 1 = Any transaction for which the No Snoop attribute is applicable but is not set within the TLP Header will be rejected as an Unsupported Request.
14:8	RO	0000000b	Reserved The Port Arbitration Capability is not valid for root ports.
7:0	RO	01h	Port Arbitration Capability (PAC) This field indicates types of Port Arbitration supported by the VC resource. This field is valid for all Switch Ports, Root Ports that support peer-to-peer traffic, and RCRBs, but not for PCI Express Endpoint devices or Root Ports that do not support peer to peer traffic. Each bit location within this field corresponds to a Port Arbitration Capability defined below. When more than one bit in this field is Set, it indicates that the VC resource can be configured to provide different arbitration services. Software selects among these capabilities by writing to the Port Arbitration Select field (see below). Defined bit positions are: Bit 0 = Non-configurable hardware-fixed arbitration scheme (such as, Round Robin (RR)) Bit 1 = Weighted Round Robin (WRR) arbitration with 32 phases Bit 2 = WRR arbitration with 64 phases Bit 3 = WRR arbitration with 128 phases Bit 4 = Time-based WRR with 128 phases Bit 5 = WRR arbitration with 256 phases Bits 6–7 = Reserved MCH default indicates "Non-configurable hardware-fixed arbitration scheme".

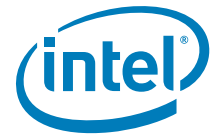

2.20.5 VCORCTL—VCO Resource Control Register

This register controls the resources associated with PCI Express Virtual Channel 0.

B/D/F/Type:		0/6/0/MMR	
Address Offset:		114–117h	
Reset Value:		800000FFh	
Access:		RO, RW	
Bit	Attr	Reset Value	Description
31	RO	1b	VCO Enable (VCOE) For VCO this is hardwired to 1 and read only as VCO can never be disabled.
30:27	RO	0h	Reserved
26:24	RO	000b	VCO ID (VCOID) Assigns a VC ID to the VC resource. For VCO this is hardwired to 0 and read only.
23:20	RO	0h	Reserved
19:17	RW	000b	Port Arbitration Select (PAS) This field configures the VC resource to provide a particular Port Arbitration service. This field is valid for RCRBs, Root Ports that support peer to peer traffic, and Switch Ports, but not for PCI Express Endpoint devices or Root Ports that do not support peer to peer traffic. The permissible value of this field is a number corresponding to one of the asserted bits in the Port Arbitration Capability field of the VC resource.
16	RO	0b	Reserved: Reserved for Load Port Arbitration Table
15:8	RO	00h	Reserved
7:1	RW	7Fh	TC/VCO Map (TCVCOM) Indicates the TCs (Traffic Classes) that are mapped to the VC resource. Bit locations within this field correspond to TC values. For example, when bit 7 is set in this field, TC7 is mapped to this VC resource. When more than one bit in this field is set, it indicates that multiple TCs are mapped to the VC resource. In order to remove one or more TCs from the TC/VC Map of an enabled VC, software must ensure that no new or outstanding transactions with the TC labels are targeted at the given Link.
0	RO	1b	TC0/VCO Map (TCOVCOM) Traffic Class 0 is always routed to VCO.



2.20.6 VCORSTS—VCO Resource Status Register

B/D/F/Type:		0/6/0/MMR	
Address Offset:		11A–11Bh	
Reset Value:		0002h	
Access:		RO	
Bit	Attr	Reset Value	Description
15:2	RO	0000h	Reserved: MBZ
1	RO	1b	<p>VCO Negotiation Pending (VCONP) 0 = The VC negotiation is complete. 1 = The VC resource is still in the process of negotiation (initialization or disabling).</p> <p>This bit indicates the status of the process of Flow Control initialization. It is set by default on Reset, as well as whenever the corresponding Virtual Channel is Disabled or the Link is in the DL_Down state. It is cleared when the link successfully exits the FC_INIT2 state.</p> <p>Before using a Virtual Channel, software must check whether the VC Negotiation Pending fields for that Virtual Channel are cleared in both Components on a Link.</p>
0	RO	0b	Reserved for Port Arbitration Table Status

2.21 Intel® Trusted Execution Technology (Intel® TXT) Specific Registers

Intel TXT configuration registers are a subset of chipset registers. These registers are mapped into two regions of memory, representing the public and private configuration spaces. Registers in the private space can only be accessed after a measured environment has been established and before the TXT.CMD.CLOSE-PRIVATE command has been issued. The private space registers are mapped to the address range starting at FED20000h. The public space registers are mapped to the address range starting at FED30000h and are available before, during and after a measured environment launch. The offsets in the table are from the start of either the public or private spaces (all registers are available within both spaces, though with different permissions).

Table 2-16. Intel® TXT Register Address Map

Address Offset	Register Symbol	Register Name	Reset Value	Access
110–117h	TXT.DID	TXT Device ID Register	00000003A0008086h	RO
330–337h	TXT.DPR	TXT DMA Protected Range	0000000000000000h	RW-L, RW-L-K, RO
400–40Fh	TXT.PUBLIC.KEY.LOWER	TXT Processor Public Key Hash Lower Half	73A13C69E7DCF24C384C652BA19DA250h	RO
410–41Fh	TXT.PUBLIC.KEY.UPPER	TXT Processor Public Key Hash Upper Half	D884C70067DFC104BFDF8368D7254DBBh	RO



2.21.1 TXT.DID—TXT Device ID Register

This register contains the TXT ID for the processor.

B/D/F/Type:		0/0/0/TXT Specific	
Address Offset:		110–117h	
Reset Value:		00000003A0008086h	
Access:		RO	
Bit	Attr	Reset Value	Description
63:48	RO	0000h	Reserved
47:32	RO	0003h	Revision ID (TXT.RID) For the initial stepping of the component, the value is 0001h. The value is a bit-mask for compatibility with prior steppings.
31:16	RO	A00h	Device ID (TXT.DID) A000h = This processor
15:0	RO	8086h	Vendor ID (TXT.VID) This register field contains the PCI standard identification for Intel, 8086h.

2.21.2 TXT.DPR—DMA Protected Range Register

This is the DMA protected range register.

B/D/F/Type:		0/0/0/TXT Specific	
Address Offset:		330–337h	
Reset Value:		0000000000000000h	
Access:		RO, RW-L, RW-L-K	
Bit	Attr	Reset Value	Description
63:32	RO	00000000h	Reserved
31:20	RO	000h	Top of DMA Protected Range (TopOfDPR) Top address + 1 of DPR. On the processor, this is the base of TSEG. Bits 19:0 of the BASE reported here are 0_0000h.
19:12	RO	00h	Reserved
11:4	RW-L	00h	DMA Protected Memory Size (DPR.SIZE) This is the size of memory, in MB, that will be protected from DMA accesses. A value of 00h in this field means no additional memory is protected. The maximum amount of memory that will be protected is 255 MB.
3:1	RO	000b	Reserved
0	RW-L-K	0b	Lock (LOCK) Bits 19:0 are locked down in this register when this bit is set. This bit is a write-once bit. If BIOS writes a 0 to the bit, then it can not be written to a 1 on subsequent writes. BIOS must write the entire register with the correct values and set this bit with that write.



2.21.3 TXT.PUBLIC.KEY.LOWER—TXT Processor Public Key Hash Lower Half Register

These registers hold the hash of the processor's public key. It is 256 bits (32 Bytes).

B/D/F/Type:		0/0/0/TXT Specific	
Address Offset:		400–40Fh	
Reset Value:		73A13C69E7DCF24C384C652BA19DA250h	
Access:		RO	
Bit	Attr	Reset Value	Description
127:0	RO	73A13C69E7DCF24C384C652BA19DA250h	Public Key Hash Lower half (TXT.PUBLIC.KEYHASH) This is a 256 bit (32 byte) field that contains the hash of the processor's public key. For the processor, the value of the processor's public key differs between Production mode and Debug mode. Debug Mode Public Key lower half: 73A13C69E7DCF24C384C652BA19DA250h Production Mode Public Key lower half: C8012D55129B7568DF3979FC2B8BDE54h

2.21.4 TXT.PUBLIC.KEY.UPPER—TXT Processor Public Key Hash Upper Half Register

B/D/F/Type:		0/0/0/TXT Specific	
Address Offset:		410–41Fh	
Reset Value:		D884C70067DFC104BFDF8368D7254DBBh	
Access:		RO	
Bit	Attr	Reset Value	Description
127:0	RO	D884C70067DFC104BFDF8368D7254DBBh	Public Key Hash Upper half (TXT.PUBLIC.KEYHASH) This is a 256 bit (32 byte) field that contains the hash of the processor's public key. For this processor, the value of the processor's public key differs between Production mode and Debug mode. Debug Mode Public Key upper half: D884C70067DFC104BFDF8368D7254DBBh Production Mode Public Key upper half: 1337927100B39E8EC9166899A0E12BE0h.





3 Intel® QuickPath Architecture System Address Decode Register Description

The processor supports PCI configuration space accesses using the mechanism denoted as Configuration Mechanism in the PCI specification as defined in the PCI Local Bus Specification, Revision 2.3, as well as the PCI Express* enhanced configuration mechanism as specified in the PCI Express Base Specification, Revision 1.1. All the registers are organized by bus, device, function, etc. as defined in the PCI Express Base Specification, Revision 1.1. All processor registers appear on the PCI bus assigned for the processor socket. Bus number is derived by the maximum bus range setting and processor socket number. All multi-byte numeric fields use “little-endian” ordering (that is, lower addresses contain the least significant parts of the field).

As processor features vary by SKU, not all of the register descriptions in this chapter apply to all processors. This document highlights registers that do not apply to all processor SKUs. Refer to the particular processor specification update for a list of features supported.

3.1 Register Terminology

Registers and register bits are assigned one or more of the following attributes. These attributes define the behavior of register and the bit(s) that are contained within. All bits are set to Reset Values by a hard reset. Sticky bits retain their states between hard resets.

Table 3-1. Register Terminology (Sheet 1 of 2)

Term	Description
RO	Read Only. If a register bit is read only, the hardware sets its state. The bit may be read by software. Writes to this bit have no effect.
WO	Write Only. The register bit is not implemented as a bit. The write causes some hardware event to take place.
RW	Read/Write. A register bit with this attribute can be read and written by software.
RC	Read Clear: The bit or bits can be read by software, but the act of reading causes the value to be cleared.
RCW	Read Clear/Write: A register bit with this attribute will get cleared after the read. The register bit can be written.
RW1C	Read/Write 1 Clear. A register bit with this attribute can be read or cleared by software. In order to clear this bit, a one must be written to it. Writing a zero will have no effect.
RW0C	Read/Write 0 Clear. A register bit with this attribute can be read or cleared by software. In order to clear this bit, a zero must be written to it. Writing a one will have no effect.
RW1S	Read/Write 1 Set: A register bit can be either read or set by software. In order to set this bit, a one must be written to it. Writing a zero to this bit has no effect. Hardware will clear this bit.
RW0S	Read/Write 0 Set: A register bit can be either read or set by software. In order to set this bit, a zero must be written to it. Writing a one to this bit has no effect. Hardware will clear this bit.
RWL	Read/Write/Lock. A register bit with this attribute can be read or written by software. Hardware or a configuration bit can lock the bit and prevent it from being updated.



Table 3-1. Register Terminology (Sheet 2 of 2)

Term	Description
RWO	Read/Write Once. A register bit with this attribute can be written to only once after power up. After the first write, the bit becomes read only. This attribute is applied on a bit by bit basis. For example, if the RWO attribute is applied to a 2 bit field, and only one bit is written, then the written bit cannot be rewritten (unless reset). The unwritten bit, of the field, may still be written once. This is special case of RWL.
RRW	Read/Restricted Write. This bit can be read and written by software. However, only supported values is written. Writes of non supported values will have no effect.
L	Lock. A register bit with this attribute becomes Read Only after a lock bit is set.
RSVD	Reserved Bit. This bit is reserved for future expansion and must not be written. The PCI Local Bus Specification, Revision 2.2 requires that reserved bits must be preserved. Any software that modifies a register that contains a reserved bit is responsible for reading the register, modifying the desired bits, and writing back the result.
Reserved Bits	Some of the processor registers described in this section contain reserved bits. These bits are labeled "Reserved". Software must deal correctly with fields that are reserved. On reads, software must use appropriate masks to extract the defined bits and not rely on reserved bits being any particular value. On writes, software must ensure that the values of reserved bit positions are preserved. That is, the values of reserved bit positions must first be read, merged with the new values for other bit positions and then written back. Note that software does not need to perform a read-merge-write operation for the Configuration Address (CONFIG_ADDRESS) register.
Reserved Registers	In addition to reserved bits within a register, the processor contains address locations in the configuration space that are marked either "Reserved" or "Intel Reserved". The processor responds to accesses to "Reserved" address locations by completing the host cycle. When a "Reserved" register location is read, a zero value is returned. ("Reserved" registers can be 8, 16, or 32 bits in size). Writes to "Reserved" registers have no effect on the processor. Registers that are marked as "Intel Reserved" must not be modified by system software. Writes to "Intel Reserved" registers may cause system failure. Reads to "Intel Reserved" registers may return a non-zero value.
Reset Value upon a Reset	Upon a reset, the processor sets all of its internal configuration registers to predetermined default states. Some register values at reset are determined by external strapping options. The default state represents the minimum functionality feature set required to successfully bring up the system. Hence, it does not represent the optimal system configuration. It is the responsibility of the system initialization software (usually BIOS) to properly determine the DRAM configurations, operating parameters and optional system features that are applicable, and to program the processor registers accordingly.
"ST" appended to the end of a bit name	The bit is "sticky" or unchanged by a hard reset. These bits can only be cleared by a PWRGOOD reset.
MBZ	Must Be Zero when writing this bit.



3.2 Platform Configuration Structure

The processor contains PCI devices within a single physical component. The configuration registers for these devices are mapped as devices residing on the PCI bus assigned for the processor socket. Bus number is derived by the maximum bus range setting and processor socket number.

- **Device 0:** Generic processor non-core
 - Device 0, Function 0 contains the generic non-core configuration registers for the processor and resides at DID (Device ID) of 2C62h.
 - Device 0, Function 1 contains the System Address Decode registers and resides at DID of 2D01h.
- **Device 2:** Intel QPI
 - Device 2, Function 0 contains the Intel® QuickPath Interconnect configuration registers for Intel QPI Link 0 and resides at DID of 2D10h.
 - Device 2, Function 1 contains the physical layer registers for Intel QPI Link 0 and resides at DID of 2D11h.

Each component in the processor is uniquely identified by a PCI bus address consisting of Bus Number, Device Number and Function Number. Device configuration is based on the PCI Type 0 configuration conventions. All processor registers appear on the PCI bus assigned for the processor socket. Bus number is derived by the maximum bus range setting and processor socket number.

Table 3-2. Functions Specifically Handled by the Processor

Component	Register Group	DID	Device	Function
Processor	Intel QuickPath Architecture Generic Non-core Registers	2C61h	0	0
	Intel QuickPath Architecture System Address Decoder	2D01h		1
	Intel QPI Link 0	2D10h	2	0
	Intel QPI Physical 0	2D11h		1
	Intel Reserved	2D12h		2
	Intel Reserved	2D13h		3



3.3 Detailed Configuration Space Maps

Table 3-3. Device 0, Function 0 — Generic Non-core Registers

DID		VID		00h					80h
PCISTS		PCICMD		04h					84h
CCR		RID		08h					88h
	HDR			0Ch					8Ch
				10h					90h
				14h					94h
				18h					98h
				1Ch					9Ch
				20h					A0h
				24h					A4h
				28h					A8h
SID		SVID		2Ch					ACh
				30h					B0h
				34h					B4h
				38h					B8h
				3Ch					BCh
				40h	CURRENT_UCLK_RATIO				C0h
				44h					C4h
				48h					C8h
				4Ch					CCh
				50h					D0h
				54h					D4h
				58h					D8h
				5Ch					DCh
MAX_RTIDS				60h					E0h
				64h					E4h
				68h					E8h
				6Ch					ECh
				70h					F0h
				74h					F4h
				78h					F8h
				7Ch					FCh

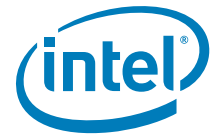

Table 3-4. Device 0, Function 1 — System Address Decoder Registers

DID		VID		00h	SAD_DRAM_RULE_0			80h
PCISTS		PCICMD		04h	SAD_DRAM_RULE_1			84h
CCR			RID	08h	SAD_DRAM_RULE_2			88h
	HDR			0Ch	SAD_DRAM_RULE_3			8Ch
				10h	SAD_DRAM_RULE_4			90h
				14h	SAD_DRAM_RULE_5			94h
				18h	SAD_DRAM_RULE_6			98h
				1Ch	SAD_DRAM_RULE_7			9Ch
				20h				A0h
				24h				A4h
				28h				A8h
SID		SVID		2Ch				ACh
				30h				B0h
				34h				B4h
				38h				B8h
				3Ch				BCh
SAD_PAM0123				40h				C0h
SAD_PAM456				44h				C4h
SAD_HEN				48h				C8h
SAD_SMRAM				4Ch				CCh
SAD_PCIEXBAR				50h				D0h
				54h				D4h
				58h				D8h
				5Ch				DCh
				60h				E0h
				64h				E4h
				68h				E8h
				6Ch				ECh
				70h				F0h
				74h				F4h
				78h				F8h
				7Ch				FCh

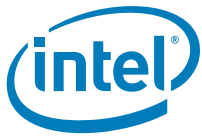

Table 3-5. Device 2, Function 0 — Intel® QPI Link 0 Registers

DID		VID		00h					80h
PCISTS		PCICMD		04h					84h
CCR			RID	08h					88h
	HDR			0Ch					8Ch
				10h					90h
				14h					94h
				18h					98h
				1Ch					9Ch
				20h					A0h
				24h					A4h
				28h					A8h
SID		SVID		2Ch					ACh
				30h					B0h
				34h					B4h
				38h					B8h
				3Ch					BCh
				40h					C0h
				44h					C4h
QPI_QPILCL_LO				48h					C8h
				4Ch					CCh
				50h					D0h
				54h					D4h
				58h					D8h
				5Ch					DCh
				60h					E0h
				64h					E4h
				68h					E8h
				6Ch					ECh
				70h					F0h
				74h					F4h
				78h					F8h
				7Ch					FCh

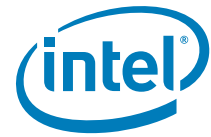

Table 3-6. Device 2, Function 1 — Intel® QPI Physical 0 Registers

DID		VID		00h	QPI_0_PH_PIS				80h
PCISTS		PCICMD		04h					84h
CCR		RID		08h					88h
	HDR			0Ch					8Ch
				10h					90h
				14h					94h
				18h					98h
				1Ch					9Ch
				20h					A0h
				24h					A4h
				28h					A8h
SID		SVID		2Ch					ACh
				30h					B0h
				34h					B4h
				38h					B8h
				3Ch					BCh
				40h					C0h
				44h					C4h
				48h					C8h
				4Ch					CCh
				50h					D0h
				54h					D4h
				58h					D8h
				5Ch					DCh
				60h					E0h
				64h					E4h
QPI_0_PH_CPR				68h					E8h
QPI_0_PH_CTR				6Ch					ECh
				70h					F0h
				74h					F4h
				78h					F8h
				7Ch					FCh



3.4 PCI Standard Registers

These registers appear in every function for every device.

3.4.1 VID—Vendor Identification Register

The VID Register contains the vendor identification number. This 16-bit register, combined with the Device Identification Register uniquely identifies the manufacturer of the function within the processor. Writes to this register have no effect.

Device: 0 Function: 0–1 Offset: 00h			
Device: 2 Function: 0–1, Offset: 00h			
Bit	Type	Reset Value	Description
15:0	RO	8086h	Vendor Identification Number The value assigned to Intel.

3.4.2 DID—Device Identification Register

This 16-bit register combined with the Vendor Identification register uniquely identifies the Function within the processor. Writes to this register have no effect. See [Section 3.2](#) for the DID of each processor function.

Device: 0 Function: 0–1 Offset: 02h			
Device: 2 Function: 0–1, Offset: 02h			
Bit	Type	Reset Value	Description
15:0	RO	*See Section 3.2	Device Identification Number This field identifies each function of the processor.

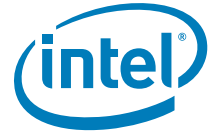

3.4.3 RID—Revision Identification Register

This register contains the revision number of the processor. The Revision ID (RID) is a traditional 8-bit Read Only (RO) register located at offset 08h in the standard PCI header of every PCI/PCI Express compatible device and function.

Device: 0 Function: 0–1 Offset: 08h			
Device: 2 Function: 0–1 Offset: 08h			
Bit	Type	Reset Value	Description
7:0	RO	0h	Revision Identification Number This is an 8-bit value that indicates the revision identification number for the processor Device 0 and 2. Refer to the <i>Intel® Core™ i5-600 and i3-500 Desktop Processor Series and Intel® Pentium® Desktop Processor 6000 Series Specification Update</i> for the value of the Revision ID Register.



3.4.4 CCR—Class Code Register

This register contains the Class Code for the device. Writes to this register have no effect.

Device:	0		
Function:	0–1		
Offset:	09h		
Device:	2		
Function:	0–1		
Offset:	09h		
Bit	Type	Reset Value	Description
23:16	RO	06h	Base Class This field indicates the general device category. For the processor, this field is hard wired to 06h, indicating it is a “Bridge Device”.
15:8	RO	0	Sub-Class This field qualifies the Base Class, providing a more detailed specification of the device function. For all devices the default is 00h, indicating “Host Bridge”.
7:0	RO	0	Register-Level Programming Interface This field identifies a specific programming interface (if any), that device independent software can use to interact with the device. There are no such interfaces defined for “Host Bridge” types, and this field is hard wired to 00h.



3.4.5 HDR—Header Type Register

This register identifies the header layout of the configuration space.

Device: 0 Function: 0–1 Offset: 0Eh Device: 2 Function: 0–1 Offset: 0Eh			
Bit	Type	Reset Value	Description
7	RO	1	Multi-function Device This bit selects whether this is a multi-function device, that may have alternative configuration layouts. This bit is hard wired to 1 for devices in the processor.
6:0	RO	0	Configuration Layout This field identifies the format of the configuration header layout for a PCI-to-PCI bridge from bytes 10h through 3Fh. For all devices, the default is 00h indicating a conventional type 00h PCI header.

3.4.6 SID/SVID—Subsystem Identity/Subsystem Vendor Identification Register

This register identifies the manufacturer of the system. This 32-bit register uniquely identifies any PCI device.

Device: 0 Function: 0–1 Offset: 2Ch, 2Eh Device: 2 Function: 0–1 Offset: 2Ch, 2Eh Access as a DWord			
Bit	Type	Reset Value	Description
31:16	RWO	8086h	Subsystem Identification Number The Reset Value specifies Intel
15:0	RWO	8086h	Vendor Identification Number The Reset Value specifies Intel.



3.4.7 PCICMD—Command Register

This register defines the PCI 3.0 compatible command register values applicable to PCI Express space.

Device:		0	
Function:		0–1	
Offset:		04h	
Device:		2	
Function:		0–1	
Offset:		04h	
Bit	Type	Reset Value	Description
15:11	RV	0	Reserved. (by PCI SIG)
10	RO	0	<p>INTxDisable: Interrupt Disable This bit controls the ability of the PCI Express port to generate INTx messages. If this device does not generate interrupts, then this bit is not implemented and is RO. If this device generates interrupts, then this bit is RW and this bit disables the device/function from asserting INTx#. A value of 0 enables the assertion of its INTx# signal. A value of 1 disables the assertion of its INTx# signal. 0 = Legacy Interrupt mode is disabled 1 = Legacy Interrupt mode is enabled</p>
9	RO	0	<p>FB2B: Fast Back-to-Back Enable This bit controls whether or not the master can do fast back-to-back writes. Since this device is strictly a target this bit is not implemented. This bit is hard wired to 0. Writes to this bit position have no effect.</p>
8	RO	0	<p>SERRE: SERR Message Enable This bit is a global enable bit for this devices SERR messaging. This host bridge will not implement SERR messaging. This bit is hard wired to 0. Writes to this bit position have no effect. If SERR is used for error generation, then this bit must be RW and enable/disable SERR signaling.</p>
7	RO	0	<p>IDSELWCC: IDSEL Stepping/Wait Cycle Control Per the PCI 2.3 specification this bit is hard wired to 0. Writes to this bit position have no effect.</p>
6	RO	0	<p>PERRE: Parity Error Response Enable Parity error is not implemented in this host bridge. This bit is hard wired to 0. Writes to this bit position have no effect.</p>
5	RO	0	<p>VGAPSE: VGA palette snoop Enable This host bridge does not implement this bit. This bit is hard wired to a 0. Writes to this bit position have no effect.</p>
4	RO	0	<p>MWIEN: Memory Write and Invalidate Enable This host bridge will never issue memory write and invalidate commands. This bit is therefore hard wired to 0. Writers to this bit position will have no effect.</p>
3	RO	0	<p>SCE: Special Cycle Enable This host bridge does not implement this bit. This bit is hard wired to a 0. Writers to this bit position will have no effect.</p>
2	RO	1	<p>BME: Bus Master Enable This host bridge is always enabled as a master. This bit is hard wired to a 1. Writes to this bit position have no effect.</p>
1	RO	1	<p>MSE: Memory Space Enable This host bridge always allows access to main memory. This bit is not implemented and is hard wired to 1. Writes to this bit position have no effect.</p>
0	RO	0	<p>IOAE: Access Enable This bit is not implemented in this host bridge and is hard wired to 0. Writes to this bit position have no effect.</p>



3.4.8 PCISTS—PCI Status Register

The PCI Status register is a 16-bit status register that reports the occurrence of various error events on this device's PCI interface.

Device:	0		
Function:	0–1		
Offset:	06h		
Device:	2		
Function:	0–1		
Offset:	06h		
Bit	Type	Reset Value	Description
15	RO	0	Detect Parity Error (DPE) The host bridge does not implement this bit and is hard wired to a 0. Writes to this bit position have no effect.
14	RO	0	Signaled System Error (SSE) This bit is set to 1 when this device generates an SERR message over the bus for any enabled error condition. If the host bridge does not signal errors using this bit, this bit is hard wired to a "0" and is read-only. Writes to this bit position have no effect.
13	RO	0	Received Master Abort Status (RMAS) This bit is set when this device generates request that receives an Unsupported Request completion packet. Software clears the bit by writing 1 to it. If this device does not receive Unsupported Request completion packets, the bit is hard wired to "0" and is read-only. Writes to this bit position have no effect.
12	RO	0	Received Target Abort Status (RTAS) This bit is set when this device generates a request that receives a Completer Abort completion packet. Software clears this bit by writing a 1 to it. If this device does not receive Completer Abort completion packets, this bit is hard wired to "0" and read-only. Writes to this bit position have no effect.
11	RO	0	Signaled Target Abort Status (STAS) This device will not generate a Target Abort completion or Special Cycle. This bit is not implemented in this device and is hard wired to a 0. Writes to this bit position have no effect.
10:9	RO	0	DEVSEL Timing (DEVT) These bits are hard wired to "00". Writes to these bit positions have no effect. This device does not physically connect to any PCI bus. These bits are set to "00" (fast decode) so that optimum DEVSEL timing for physical PCI busses are not limited by this device.
8	RO	0	Master Data Parity Error Detected (DPD) PERR signaling and messaging are not implemented by this bridge, therefore this bit is hard wired to 0. Writes to this bit position have no effect.
7	RO	1	Fast Back-to-Back (FB2B) This bit is hard wired to 1. Writes to this bit position have no effect. This device is not physically connected to a PCI bus. This bit is set to 1 (indicating back-to-back capabilities) so that the optimum setting for this PCI bus is not limited by this device.
6	RO	0	Reserved
5	RO	0	66 MHz Capable Does not apply to PCI Express. Must be hard wired to 0.

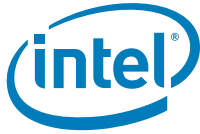

Device: 0 Function: 0–1 Offset: 06h Device: 2 Function: 0–1 Offset: 06h			
Bit	Type	Reset Value	Description
4	RO	0	Capability List (CLIST) This bit is hard wired to 1 to indicate to the configuration software that this device/function implements a list of new capabilities. A list of new capabilities is accessed using registers CAPPTR at the configuration address offset 34h from the start of the PCI configuration space header of this function. Register CAPPTR contains the offset pointing to the start address with configuration space of this device where the capability register resides. This bit must be set for a PCI Express device or if the VSEC capability. If no capability structures are implemented, this bit is hard wired to 0.
3	RO	0	Interrupt Status If this device generates an interrupt, then this read-only bit reflects the state of the interrupt in the device/function. Only when the Interrupt Disable bit in the command register is a 0 and this Interrupt Status bit is a 1, will the device's/function's INTx# signal be asserted. Setting the Interrupt Disable bit to a 1 has no effect on the state of this bit. If this device does not generate interrupts, then this bit is not implemented (RO and reads returns 0).
2:0	RO	0	Reserved



3.5 Generic Non-core Registers

3.5.1 MAX_RTIDS

Maximum number of RTIDs other homes have. How many requests can this caching agent send to the other home agents. This number is one more than the highest numbered RTID to use. Note that these values reset to 2, and need to be increased by BIOS to whatever the home agents can support.

Device: 0 Function: 0 Offset: 60h Access as a Dword			
Bit	Type	Reset Value	Description
31:22	RV	000h	Reserved
21:16	RW	2	LOCAL_MC Maximum number of RTIDs for the local home agent.
15:14	RV	00b	Reserved
13:8	RW	2h	SIBLING Maximum number of RTIDs for the sibling home agent.
7:6	RV	00b	Reserved
5:0	RW	2h	CHIPSET Maximum number of RTIDs for the IOH home agent.

3.6 SAD—System Address Decoder Registers

3.6.1 SAD_PAM0123

This register is for legacy Device 0, Function 0 90h–93h address space.

Device: 0 Function: 1 Offset: 40h Access as a Dword			
Bit	Type	Reset Value	Description
31:30	RV	0	Reserved
29:28	RW	0	PAM3_HIENABLE. 0D4000h–0D7FFFh Attribute (HIENABLE) This field controls the steering of read and write cycles that address the BIOS area from 0D4000h to 0D7FFFh. 00 = DRAM Disabled: All accesses are directed to ESI. 01 = Read Only: All reads are sent to DRAM. All writes are forwarded to ESI. 10 = Write Only: All writes are sent to DRAM. Reads are serviced by ESI. 11 = Normal DRAM Operation: All reads and writes are serviced by DRAM.
27:26	RV	0	Reserved



Device:		0	
Function:		1	
Offset:		40h	
Access as a Dword			
Bit	Type	Reset Value	Description
25:24	RW	0	PAM3_LOENABLE. 0D0000h–0D3FFFh Attribute (LOENABLE) This field controls the steering of read and write cycles that address the BIOS area from 0D0000h to 0D3FFFh. 00 = DRAM Disabled: All accesses are directed to ESI. 01 = Read Only: All reads are sent to DRAM. All writes are forwarded to ESI. 10 = Write Only: All writes are sent to DRAM. Reads are serviced by ESI. 11 = Normal DRAM Operation: All reads and writes are serviced by DRAM.
23:22	RV	0	Reserved
21:20	RW	0	PAM2_HIENABLE. 0CC000h–0CFFFFh Attribute (HIENABLE) This field controls the steering of read and write cycles that address the BIOS area from 0CC000h to 0CFFFFh. 00 = DRAM Disabled: All accesses are directed to ESI. 01 = Read Only: All reads are sent to DRAM. All writes are forwarded to ESI. 10 = Write Only: All writes are sent to DRAM. Reads are serviced by ESI. 11 = Normal DRAM Operation: All reads and writes are serviced by DRAM.
19:18	RV	0	Reserved
17:16	RW	0	PAM2_LOENABLE. 0C8000h–0CBFFFh Attribute (LOENABLE) This field controls the steering of read and write cycles that address the BIOS area from 0C8000h to 0CBFFFh. 00 = DRAM Disabled: All accesses are directed to ESI. 01 = Read Only: All reads are sent to DRAM. All writes are forwarded to ESI. 10 = Write Only: All writes are sent to DRAM. Reads are serviced by ESI. 11 = Normal DRAM Operation: All reads and writes are serviced by DRAM.
15:14	RV	0	Reserved
13:12	RW	0	PAM1_HIENABLE. 0C4000h–0C7FFFh Attribute (HIENABLE) This field controls the steering of read and write cycles that address the BIOS area from 0C4000h to 0C7FFFh. 00 = DRAM Disabled: All accesses are directed to ESI. 01 = Read Only: All reads are sent to DRAM. All writes are forwarded to ESI. 10 = Write Only: All writes are sent to DRAM. Reads are serviced by ESI. 11 = Normal DRAM Operation: All reads and writes are serviced by DRAM.
11:10	RV	0	Reserved
9:8	RW	0	PAM1_LOENABLE. 0C0000h–0C3FFFh Attribute (LOENABLE) This field controls the steering of read and write cycles that address the BIOS area from 0C0000h to 0C3FFFh. 00 = DRAM Disabled: All accesses are directed to ESI. 01 = Read Only: All reads are sent to DRAM. All writes are forwarded to ESI. 10 = Write Only: All writes are sent to DRAM. Reads are serviced by ESI. 11 = Normal DRAM Operation: All reads and writes are serviced by DRAM.
7:6	RV	0	Reserved
5:4	RW	0	PAM0_HIENABLE. 0F0000h–0FFFFFFh Attribute (HIENABLE) This field controls the steering of read and write cycles that address the BIOS area from 0F0000h to 0FFFFFFh. 00 = DRAM Disabled: All accesses are directed to ESI. 01 = Read Only: All reads are sent to DRAM. All writes are forwarded to ESI. 10 = Write Only: All writes are sent to DRAM. Reads are serviced by ESI. 11 = Normal DRAM Operation: All reads and writes are serviced by DRAM.
3:0	RV	0	Reserved



3.6.2 SAD_PAM456

This register is for legacy Device 0, Function 0 94h–97h address space.

Device: 0 Function: 1 Offset: 44h Access as a Dword			
Bit	Type	Reset Value	Description
31:22	RV	0	Reserved
21:20	RW	0	PAM6_HIENABLE. 0EC000h–0EFFFFh Attribute (HIENABLE) This field controls the steering of read and write cycles that address the BIOS area from 0EC000h to 0EFFFFh. 00 = DRAM Disabled: All accesses are directed to ESI. 01 = Read Only: All reads are sent to DRAM. All writes are forwarded to ESI. 10 = Write Only: All writes are sent to DRAM. Reads are serviced by ESI. 11 = Normal DRAM Operation: All reads and writes are serviced by DRAM.
19:18	RV	0	Reserved
17:16	RW	0	PAM6_LOENABLE. 0E8000h–0EBFFFh Attribute (LOENABLE) This field controls the steering of read and write cycles that address the BIOS area from 0E8000h to 0EBFFFh. 00 = DRAM Disabled: All accesses are directed to ESI. 01 = Read Only: All reads are sent to DRAM. All writes are forwarded to ESI. 10 = Write Only: All writes are sent to DRAM. Reads are serviced by ESI. 11 = Normal DRAM Operation: All reads and writes are serviced by DRAM.
15:14	RV	0	Reserved
13:12	RW	0	PAM5_HIENABLE. 0E4000h–0E7FFFh Attribute (HIENABLE) This field controls the steering of read and write cycles that address the BIOS area from 0E4000h to 0E7FFFh. 00 = DRAM Disabled: All accesses are directed to ESI. 01 = Read Only: All reads are sent to DRAM. All writes are forwarded to ESI. 10 = Write Only: All writes are sent to DRAM. Reads are serviced by ESI. 11 = Normal DRAM Operation: All reads and writes are serviced by DRAM.
11:10	RV	0	Reserved
9:8	RW	0	PAM5_LOENABLE. 0E0000h–0E3FFFh Attribute (LOENABLE) This field controls the steering of read and write cycles that address the BIOS area from 0E0000h to 0E3FFFh. 00 = DRAM Disabled: All accesses are directed to ESI. 01 = Read Only: All reads are sent to DRAM. All writes are forwarded to ESI. 10 = Write Only: All writes are sent to DRAM. Reads are serviced by ESI. 11 = Normal DRAM Operation: All reads and writes are serviced by DRAM.
7:6	RV	0	Reserved
5:4	RW	0	PAM4_HIENABLE. 0DC000h–0DFFFFh Attribute (HIENABLE) This field controls the steering of read and write cycles that address the BIOS area from 0DC000h to 0DFFFFh. 00 = DRAM Disabled: All accesses are directed to ESI. 01 = Read Only: All reads are sent to DRAM. All writes are forwarded to ESI. 10 = Write Only: All writes are sent to DRAM. Reads are serviced by ESI. 11 = Normal DRAM Operation: All reads and writes are serviced by DRAM.
3:2	RV	0	Reserved
1:0	RW	0	PAM4_LOENABLE. 0D8000h–0DBFFFh Attribute (LOENABLE) This field controls the steering of read and write cycles that address the BIOS area from 0D8000h to 0DBFFFh. 00 = DRAM Disabled: All accesses are directed to ESI. 01 = Read Only: All reads are sent to DRAM. All writes are forwarded to ESI. 10 = Write Only: All writes are sent to DRAM. Reads are serviced by ESI. 11 = Normal DRAM Operation: All reads and writes are serviced by DRAM.



3.6.3 SAD_HEN

This register is for legacy Hole Enable.

Device: 0 Function: 1 Offset: 48h Access as a Dword			
Bit	Type	Reset Value	Description
31:8	RV	0	Reserved
7	RW	0	HEN This bit enables a memory hole in DRAM space. The DRAM that lies "behind" this space is not remapped. 0 = No Memory hole. 1 = Memory hole from 15 MB to 16 MB.
6:0	RV	0	Reserved



3.6.4 SAD_SMRAM

This register is for legacy 9Dh address space.

Note: This register must be programmed consistently with any other registers controlling access to SMM space within the system, such as on IOH devices if present.

Device: 0 Function: 1 Offset: 4Ch Access as a Dword			
Bit	Type	Reset Value	Description
31:15	RV	0	Reserved
14	RW	0	SMM Space Open (D_OPEN) When D_OPEN=1 and D_LCK=0, the SMM space DRAM is made visible even when SMM decode is not active. This is intended to help BIOS initialize SMM space. Software should ensure that D_OPEN=1 and D_CLS=1 are not set at the same time.
13	RW	0	SMM Space Closed (D_CLS) When D_CLS = 1 SMM space DRAM is not accessible to data references, even if SMM decode is active. Code references may still access SMM space DRAM. This will allow SMM software to reference through SMM space to update the display even when SMM is mapped over the VGA range. Software should ensure that D_OPEN=1 and D_CLS=1 are not set at the same time.
12	RW1S	0	SMM Space Locked (D_LCK) When D_LCK is set to 1 then D_OPEN is reset to 0 and D_LCK, D_OPEN, C_BASE_SEG, G_SMRAME, PCIEXBAR, (DRAM_RULES and INTERLEAVE_LISTS) become read only. D_LCK can be set to 1 using a normal configuration space write but can only be cleared by a Reset. The combination of D_LCK and D_OPEN provide convenience with security. The BIOS can use the D_OPEN function to initialize SMM space and then use D_LCK to "lock down" SMM space in the future so that no application software (or BIOS itself) can violate the integrity of SMM space, even if the program has knowledge of the D_OPEN function. Note that TAD does not implement this lock.
11	RW	0	Global SMRAM Enable (G_SMRAME) If set to a 1, then Compatible SMRAM functions are enabled, providing 128 KB of DRAM accessible at the A0000h address while in SMM (ADSB with SMM decode). To enable Extended SMRAM function this bit has to be set to 1. Once D_LCK is set, this bit becomes read only.
10:8	RO	–	Compatible SMM Space Base Segment (C_BASE_SEG) This field indicates the location of SMM space. SMM DRAM is not remapped. It is simply made visible if the conditions are right to access SMM space, otherwise the access is forwarded to HI. Only SMM space between A0000h and BFFFFh is supported so this field is hard wired to 010.
7:0	RV	–	Reserved



3.6.5 SAD_PCIEXBAR

This is the Global register for PCIEXBAR address space.

Device: 0 Function: 1 Offset: 50h Access as a QWord			
Bit	Type	Reset Value	Description
63:40	RV	0	Reserved
39:20	RW	0	ADDRESS This field contains the Base address of PCIEXBAR. It must be naturally aligned to size; low order bits are ignored.
19:4	RV	0	Reserved
3:1	RW	0	SIZE Size of the PCIEXBAR address space. (Maximum bus number). 000 = 256 MB. 001 = Reserved 010 = Reserved 011 = Reserved 100 = Reserved 101 = Reserved 110 = 64 MB 111 = 128 MB
0	RW	0	ENABLE Enable for PCIEXBAR address space. Editing size should not be done without also enabling range.



3.6.6 SAD_DRAM_RULE_0, SAD_DRAM_RULE_1, SAD_DRAM_RULE_2, SAD_DRAM_RULE_3, SAD_DRAM_RULE_4, SAD_DRAM_RULE_5, SAD_DRAM_RULE_6, SAD_DRAM_RULE_7

This register provides the SAD DRAM rules. Address Map for package determination.

Device: 0 Function: 1 Offset: 80h, 84h, 88h, 8Ch, 90h, 94h, 98h, 9Ch Access as a Dword			
Bit	Type	Reset Value	Description
31:20	RV	0	Reserved
19:6	RW	–	LIMIT DRAM rule top limit address. Must be strictly greater than previous rule, even if this rule is disabled, unless this rule and all following rules are disabled. Lower limit is the previous rule (or 0 if it is first rule). This field is compared against MA[39:26] in the memory address map.
5:3	RV	0	Reserved
2:1	RW	–	MODE DRAM rule interleave mode. If a DRAM_RULE hits a 3 bit number is used to index into the corresponding interleave_list to determine which package the DRAM belongs to. This mode selects how that number is computed. 00 = Address bits {8,7,6}. 01 = Address bits {8,7,6} XORed with {18,17,16}. 10 = Address bit {6}, MOD3(Address[39..6]). (Note 6 is the high order bit) 11 = Reserved.
0	RW	0	ENABLE Enable for DRAM rule. If Enabled Range between this rule and previous rule is Directed to HOME channel (unless overridden by other dedicated address range registers). If disabled, all accesses in this range are directed in MMIO to the IOH.



3.7 Intel® QPI Link Registers

3.7.1 QPI_QPILCL_L0, QPI_QPILCL_L1

This register provides Intel QPI Link Control.

Device:		2	
Function:		0	
Offset:		48h	
Access as a Dword			
Bit	Type	Reset Value	Description
31:22	RV	0	Reserved
21	RW	0	L1_MASTER This bit indicates that this end of the link is the L1 master. This link transmitter bit is an L1 power state master and can initiate an L1 power state transition. If this bit is not set, then the link transmitter is an L1 power state slave and should respond to L1 transitions with an ACK or NACK. If the link power state of L1 is enabled, then there is one master and one slave per link. The master may only issue single L1 requests, while the slave can only issue single L1_Ack or L1_NAck responses for the corresponding request.
20	RW	0	L1_ENABLE This bit enables L1 mode at the transmitter. This bit should be ANDed with the receive L1 capability bit received during parameter exchange to determine if a transmitter is allowed to enter into L1. This is NOT a bit that determines the capability of a device.
19	RV	0	Reserved
18	RW	0	LOS_ENABLE This bit enables L0s mode at the transmitter. This bit should be ANDed with the receive L0s capability bit received during parameter exchange to determine if a transmitter is allowed to enter into L0s. This is NOT a bit that determines the capability of a device.
17:0	RW	0	Intel Reserved



3.8 Intel® QPI Physical Layer Registers

3.8.1 QPI_0_PH_CPR, QPI_1_PH_CPR

This is the Intel QPI Physical Layer Capability Register.

Device: 2 Function: 1 Offset: 68h Access as a Dword			
Bit	Type	Reset Value	Description
31:30	RV	–	Reserved
29	RO	–	LFSR_POLYNOMIAL. Agent's ITU polynomial capability for loopback.
28:24	RO	–	NUMBER_OF_TX_LANES Number of Tx lanes with which an implementation can operate for full width. Bit 28 – If set, 20 lanes. The bit indicating the maximum lanes will determine the number of control/status bits implemented in Tx/Rx Data Lane Control/Status Registers.
23	RO	–	PRBS_CAPABILITY If set, implementation is capable of using specified pattern in bitlock/retraining.
22	RO	–	SCRAMBLE_CAPABILITY If set, implementation is capable of data scrambling/descrambling with LFSR.
21:20	RO	–	RAS_CAPABILITY Any of these bits set indicates Alternate Clock RAS capability available and that corresponding control bits in QPI*_PH_CTR are implemented.
19:18	RV	–	Reserved
17:16	RO	–	DETERMINISM_SUPPORT Determinism supported mode of operations. Bit 17 = If set, Master mode of operation supported. Component Specification or equivalent document should contain the information about PhyLOSynch. Bit 16 = If set, Slave mode of operation supported.
15:11	RV	0	Reserved
10:8	RO	–	LINK_WIDTH_CAPABILITY Bit 8: If set, Full Width capable.
7:5	RO	0	DEBUG_CAPABILITY Bit 7 = If set, an implementation is not capable of extracting slave electrical parameter from TS.Loopback and apply during the test. Bit 6 = If set, an implementation is not capable of running in Compliance slave mode as well as transitioning to Loopback.Pattern from Compliance state. Bit 5 = If set, an implementation is not capable of doing Loopcount Stal
4	RO	0	RETRAIN_GRANULARITY If set, implementation is capable of 16UI granularity in retraining duration.
3:0	RO	–	PHY_VERSION This is the Intel QPI Phy version. 0 = Current Intel QPI version 0. Others = Reserved.



3.8.2 QPI_0_PH_CTR, QPI_1_PH_CTR

This is the Intel QPI Physical Layer Control Register.

Device:		2	
Function:		1	
Offset:		6Ch	
Access as a Dword			
Bit	Type	Reset Value	Description
31:28	RV	0	Reserved
27	RW	0	LA_LOAD_DISABLE This bit disables the loading of the effective values of the Intel QPI CSRs when set.
26:24	RV	0	Reserved
23	RW	0	ENABLE_PRBS This bit enables LFSR pattern during bitlock/training. 1 = Use pattern in bitlock/retraining. 0 = Use clock pattern for bitlock/retraining.
22	RW	0	ENABLE_SCRAMBLE This bit enables data scrambling through LFSR. 1 = Data scrambled/descrambled with LFSR 0 = Data not scrambled/descrambled.
21:16	RV	0	Reserved
15:14	RW	2	DETERMINISM_MODE . Sets determinism mode of operation. 00 = Non-deterministic initialization. 01 = Slave mode initialization. 10 = Master mode of initialization - valid only if a component can generate its PhyL0Synch.
13	RW	1	DISABLE_AUTO_COMP . Disables automatic entry into compliance. 0 = Path from detect.clkterm to compliance is allowed. 1 = Path from detect.clkterm to compliance is disabled.
12	RW	0	INIT_FREEZE When this bit is set, it freezes the FSM when initialization aborts.
11	RW	0	DISABLE_ISI_CHECK Defeature mode to disable ISI checking during Polling.LaneDeskew state.
10:8	RW	0	INIT_MODE Initialization mode that determines altered initialization modes.
7	RW	0	LINK_SPEED . Identifies slow speed or at-speed operation for the Intel QPI port. 1 = Force direct operational speed initialization. 0 = Slow speed initialization.
6	RV	0	Reserved
5	RW	1	PHYINITBEGIN . Instructs the port to start initialization.
4	RW	0	SINGLE_STEP . Enables single step mode.
3	RW	0	LAT_FIX_CTL . If set, instructs the remote agent to fix the latency.
2	RW	0	BYPASS_CALIBRATION . Indicates the physical layer to bypass calibration.
1	RW	0	RESET_MODIFIER . Modifies soft reset to default reset when set.
0	RW1S	0	PHY_RESET . Physical Layer Reset.

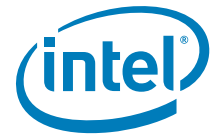

3.8.3 QPI_0_PH_PIS, QPI_1_PH_PIS

This is an Intel QPI Physical Layer Initialization Status Register.

Bit	Type	Reset Value	Description
Device: 2 Function: 1 Offset: 80h Access as a Dword			
31:30	RV	–	Reserved
29	RO	–	GLOBAL_ERROR Set upon any error detected on the link during Loopback Pattern.
28	RO	–	TEST_BUSY Test busy bit indicating that a test is in progress.
27	RW1C	0	STATE_HOLD . State machine hold bit for single step and init freeze modes.
26	RO	–	INIT_SPEED . Current initialization speed. 1 = Operational Speed Initialization. 0 = Slow Speed Initialization.
25	RO	–	PORT_RMT_ACK . Port Remote ACK status.
24	RO	–	PORT_TX_RDY . Port Tx Ready status.
23:21	RV	–	Reserved
20:16	RO	–	RX_STATE . Current state of the local Rx.
15:13	RV	–	Reserved
12:8	RO	–	TX_STATE . Current state of the local Tx.
7:2	RV	–	Reserved
1	RW1C	0	CALIBRATION_DONE . This bit indicates that calibration has been completed for the Intel QPI link.
0	RW1C	0	LINKUP_IDENTIFIER . Link up identifier for the Intel QPI link. Set to 0 during Default Reset. Set to 1 when initialization completes and link enters L0.

§ §

