



VT8233A

V-LINK CLIENT HIGHLY INTEGRATED SOUTH BRIDGE

**HIGH BANDWIDTH V-LINK CLIENT CONTROLLER
INTEGRATED DIRECT SOUND AC97 AUDIO,
ULTRADMA-133/100/66/33 MASTER MODE EIDE CONTROLLER,
FOUR PORT USB CONTROLLER, KEYBOARD/MOUSE CONTROLLER,
RTC, LPC, SMBUS, SERIAL IRQ, PLUG AND PLAY, ACPI,
and PC99 COMPLIANT Enhanced Power Management**

Revision 1.21
May 8, 2002

VIA TECHNOLOGIES, INC.

Copyright Notice:

Copyright © 2001, 2002 VIA Technologies Incorporated. Printed in the United States. ALL RIGHTS RESERVED.

No part of this document may be reproduced, transmitted, transcribed, stored in a retrieval system, or translated into any language, in any form or by any means, electronic, mechanical, magnetic, optical, chemical, manual or otherwise without the prior written permission of VIA Technologies Incorporated.

VT8233, VT8233C, and VT8233A may only be used to identify products of VIA Technologies.

Cyrix6x86™ and VIA C3™ are registered trademarks of VIA Technologies.

AMD6x86™, AMD-K6™, AMD-K7™ and Athlon™ are registered trademarks of Advanced Micro Devices

Celeron™, Pentium™, Pentium-III™, Pentium-4™, MMX™, and Intel™, are registered trademarks of Intel Corp.

PS/2™ is a registered trademark of International Business Machines Corp.

Windows 98™, Windows 2000™, Windows XP™, and Plug and Play™ are registered trademarks of Microsoft Corp.

PCI™ is a registered trademark of the PCI Special Interest Group.

VESA™ is a trademark of the Video Electronics Standards Association.

All trademarks are the properties of their respective owners.

Disclaimer Notice:

No license is granted, implied or otherwise, under any patent or patent rights of VIA Technologies. VIA Technologies makes no warranties, implied or otherwise, in regard to this document and to the products described in this document. The information provided by this document is believed to be accurate and reliable to the publication date of this document. However, VIA Technologies assumes no responsibility for any errors in this document. Furthermore, VIA Technologies assumes no responsibility for the use or misuse of the information in this document and for any patent infringements that may arise from the use of this document. The information and product specifications within this document are subject to change at any time, without notice and without obligation to notify any person of such change.

Offices:

USA Office:

940 Mission Court

Fremont, CA 94539

USA

Tel: (510) 683-3300

Fax: (510) 683-3301 or (510) 687-4654

Web: <http://www.viatech.com>

Taipei Office:

8th Floor, No. 533

Chung-Cheng Road, Hsin-Tien

Taipei, Taiwan ROC

Tel: (886-2) 2218-5452

Fax: (886-2) 2218-5453

Web: <http://www.via.com.tw>

REVISION HISTORY

Document Release	Date	Revision	Initials
1.0	1/31/02	Initial public release; same as internal revision 0.5 with additional typographical error fixes in pin lists and minor edits in pin descriptions and electrical tables	DH
1.01	2/4/02	Updated cover and page 1 part descriptions to match Fixed company phone numbers on "legal page" Fixed feature bullets to indicate two USB root hubs not three Fixed VLVREF pin name in pin description tables Removed Device 0 Func 4 and Device 1 Func 0 from Table 5 Function Summary	DH
1.1	2/11/02	Added Function 0 Rx8C[1] & E5[6], Updated PMIO Rx0[4] and Function 1 Rx54[3]	DH
1.2	2/26/02	Fixed APIC "I/O Redirection Table Entry" format for bits 10-8 = 001b Updated Device 17 Function 0 Rx8, 4C[3-0], 7C[3-0], 80[6], 96[4] Updated PMIO Rx10[7], 20[15], 22[15], 24[15-14], 5C[1]	DH
1.21	5/8/02	Updated VIA USA street address and "online services" formatting on legal page Fixed typo in SMB I/O registers header text	DH

TABLE OF CONTENTS

REVISION HISTORY	I
TABLE OF CONTENTS.....	II
LIST OF FIGURES	IV
LIST OF TABLES	IV
PRODUCT FEATURES.....	1
OVERVIEW.....	4
DIFFERENCES BETWEEN THE VT8233 (VERSION CE), VT8233C, AND VT8233A	4
PINOUTS.....	6
PIN DIAGRAM	6
PIN LISTS	7
PIN DESCRIPTIONS.....	9
REGISTERS.....	20
REGISTER OVERVIEW	20
REGISTER DESCRIPTIONS	30
Legacy I/O Ports	30
Keyboard Controller I/O Registers	31
DMA Controller I/O Registers.....	33
Interrupt Controller I/O Registers	34
Timer / Counter Registers	34
CMOS / RTC I/O Registers	35
Keyboard / Mouse Wakeup Index / Data Registers.....	36
Keyboard / Mouse Wakeup Registers.....	36
Memory Mapped I/O APIC Registers	37
Indexed I/O APIC Registers	37
Configuration Space I/O	39
Device 17 Function 0 Registers – Bus Control and Power Management.....	40
PCI Configuration Space Header	40
ISA Bus Control.....	41
Miscellaneous Control	43
Function Control	44
Serial IRQ, LPC, and PC/PCI DMA Control	44
Plug and Play Control - PCI.....	45
GPIO and Miscellaneous Control	46
Programmable Chip Select Control.....	47
ISA Decoding Control	48
Power Management-Specific Configuration Registers	50
System Management Bus-Specific Configuration Registers.....	57
General Purpose I/O Control Registers	58
Power Management I/O-Space Registers.....	59
System Management Bus I/O-Space Registers	68
Device 17 Function 1 Registers - Enhanced IDE Controller.....	71
PCI Configuration Space Header	71
IDE-Controller-Specific Configuration Registers.....	73
IDE Power Management Registers	77
IDE Back Door Registers.....	77
IDE I/O Registers.....	77
Device 17 Function 2 Registers - USB Controller Ports 0-1.....	78

PCI Configuration Space Header	78
USB-Specific Configuration Registers	79
USB I/O Registers.....	80
Device 17 Function 3 Registers - USB Controller Ports 2-3.....	81
PCI Configuration Space Header	81
USB-Specific Configuration Registers	82
USB I/O Registers.....	83
Device 17 Function 5 Registers - AC97 Audio Controller.....	84
PCI Configuration Space Header	84
Audio-Specific PCI Configuration Registers	85
I/O Base 0 Regs – Audio Scatter / Gather DMA.....	87
Device 17 Function 6 Registers - AC97 Modem Controller	94
PCI Configuration Space Header	94
Modem-Specific PCI Configuration Registers.....	95
I/O Base 0 Regs – Modem Scatter / Gather DMA	97
FUNCTIONAL DESCRIPTIONS.....	100
POWER MANAGEMENT.....	100
Power Management Subsystem Overview	100
Processor Bus States	100
System Suspend States and Power Plane Control	101
General Purpose I/O Ports.....	101
Power Management Events.....	102
System and Processor Resume Events	102
Legacy Power Management Timers.....	103
System Primary and Secondary Events.....	103
Peripheral Events	103
ELECTRICAL SPECIFICATIONS	104
ABSOLUTE MAXIMUM RATINGS	104
DC CHARACTERISTICS	104
POWER REQUIREMENTS.....	105
PACKAGE MECHANICAL SPECIFICATIONS.....	106

LIST OF FIGURES

FIGURE 1. PC SYSTEM CONFIGURATION USING THE VT8233A.....	5
FIGURE 2. VT8233A BALL DIAGRAM (TOP VIEW)	6
FIGURE 3. POWER MANAGEMENT SUBSYSTEM BLOCK DIAGRAM.....	100
FIGURE 4. SYSTEM BLOCK DIAGRAM USING THE VT8633 NORTH BRIDGE.....	102
FIGURE 5. MECHANICAL SPECIFICATIONS – 376 PIN BALL GRID ARRAY PACKAGE	106

LIST OF TABLES

TABLE 1. VT8233A PIN LIST (<u>NUMERICAL ORDER</u>).....	7
TABLE 2. VT8233A PIN LIST (<u>ALPHABETICAL ORDER</u>).....	8
TABLE 3. PIN DESCRIPTIONS	9
TABLE 4. MEMORY MAPPED REGISTERS	20
TABLE 5. FUNCTION SUMMARY.....	20
TABLE 6. SYSTEM I/O MAP	20
TABLE 7. REGISTERS	21
TABLE 8. KEYBOARD CONTROLLER COMMAND CODES	32
TABLE 9. CMOS REGISTER SUMMARY	35
TABLE 10. PNP IRQ ROUTING TABLE	45

VT8233A

V-LINK CLIENT

HIGHLY INTEGRATED SOUTH BRIDGE

**HIGH BANDWIDTH V-LINK CLIENT CONTROLLER
INTEGRATED DIRECT SOUND AC97 AUDIO,
ULTRADMA-133/100/66/33 MASTER MODE EIDE CONTROLLER,
FOUR PORT USB CONTROLLER, KEYBOARD CONTROLLER, RTC,
LPC, SMBUS, SERIAL IRQ, PLUG AND PLAY, ACPI,
AND PC99 COMPLIANT ENHANCED POWER MANAGEMENT**

PRODUCT FEATURES

- **Inter-operable with VIA Host-to-V-Link Host Controller**
 - Combine with VT8753A (Apollo P4X266A) for a complete 533 / 400 MHz FSB Pentium 4 system
 - Combine with VT8633 (Apollo Pro266) for a complete 133 / 100 MHz FSB Pentium 3 / VIA C3 Socket-370 system
 - Combine with VT8366 (Apollo KT266) for a complete 266 / 200 MHz FSB Athlon / Duron Socket-A system
 - May be used interchangeably with the VT8233 or VT8233C South Bridge in most board designs †
- **High Bandwidth 266 MB/S 8-bit V-Link Client Controller**
 - Supports 66 MHz V-Link Client interface with peak bandwidth of 266 MB/S
 - V-Link operates in 2X or 4X modes
 - Full duplex commands with separate Strobe / Command
 - Request / Data split transaction
 - Configurable outstanding transaction queue for V-Link Client accesses
 - Auto Client Retry to eliminate V-Link Host-Client Retry cycles
 - Intelligent V-Link transaction protocol to eliminate data wait-state / throttle transfer latency; all V-Link transactions for both Host and Client have a consistent view of transaction data depth and buffer size to avoid data overflow.
 - Highly efficient V-Link arbitration with minimum overhead; all V-Link transactions have predictable cycle length with known Command / Data duration
 - Auto connect / reconnect capability for minimum power consumption
- **Integrated Peripheral Controllers**
 - Integrated USB Controller with two root hubs and four function ports
 - Dual channel UltraDMA-133 / 100 / 66 / 33 master mode EIDE controller
 - AC-link interface for AC-97 audio codec and modem codec
 - HSP modem support
 - Integrated DirectSound compatible digital audio controller
 - LPC interface for Low Pin Count interface to Super-I/O or ROM
- **Integrated Legacy Functions**
 - Integrated Keyboard Controller with PS2 mouse support
 - Integrated DS12885-style Real Time Clock with extended 256 byte CMOS RAM and Day/Month Alarm for ACPI
 - Integrated DMA, timer, and interrupt controller
 - Serial IRQ for docking and non-docking applications
 - Fast reset and Gate A20 operation

† See Overview for a list of differences between the VT8233, VT8233C and VT8233A

- **Concurrent PCI Bus Controller**
 - 33 MHz operation
 - Supports up to five PCI masters
 - Peer concurrency
 - Concurrent multiple PCI master transactions; i.e., allow PCI masters from both PCI buses active at the same time
 - Zero wait state PCI master and slave burst transfer rate
 - PCI to system memory data streaming up to 132Mbyte/sec (data sent to north bridge via high speed V-Link Interface)
 - PCI master snoop ahead and snoop filtering
 - Eight DW of CPU to PCI posted write buffers
 - Byte merging in the write buffers to reduce the number of PCI cycles and to create further PCI bursting possibilities
 - Enhanced PCI command optimization (MRL, MRM, MWI, etc.)
 - Four lines of post write buffers from PCI masters to DRAM
 - Sixteen levels (double-words) of prefetch buffers from DRAM for access by PCI masters
 - Delay transaction from PCI master accessing DRAM
 - Transaction timer for fair arbitration between PCI masters (granularity of two PCI clocks)
 - Symmetric arbitration between Host/PCI bus for optimized system performance
 - Complete steerable PCI interrupts
 - PCI-2.2 compliant, 32 bit 3.3V PCI interface with 5V tolerant inputs
- **UltraDMA-133 / 100 / 66 / 33 Master Mode EIDE Controller**
 - Dual channel master mode hard disk controller supporting four Enhanced IDE devices
 - Transfer rate up to 133MB/sec to cover PIO mode 4, multi-word DMA mode 2 drives, and UltraDMA-133 interface
 - Increased reliability using UltraDMA-133/100/66 transfer protocols
 - Thirty-two levels (doublewords) of prefetch and write buffers
 - Dual DMA engine for concurrent dual channel operation
 - Bus master programming interface for SFF-8038i rev.1.0 and Windows-95 compliant
 - Full scatter gather capability
 - Support ATAPI compliant devices including DVD devices
 - Support PCI native and ATA compatibility modes
 - Complete software driver support
- **Direct Sound Ready AC97 Digital Audio Controller**
 - AC-Link access to 4 CODECs (AC97 + AMC97 + MC97)
 - Multichannel Audio
 - Bus Master Scatter / Gather DMA
 - Dedicated read and write channels supporting simultaneous stereo playback and record
 - Dedicated read and write channels supporting simultaneous modem receive and transmit
 - 1 stereo DirectSound channel with source / volume control / mixer
 - 1 shared FM / SPDIF PCM read channel
 - 1 dedicated channel supporting multi-channel audio
 - 32-byte line-buffers for each SGD channel
 - Programmable 8bit / 16bit mono / stereo PCM data format support
 - AC97 2.1 compliant
- **System Management Bus Interface**
 - Host interface for processor communications
 - Slave interface for external SMBus masters
- **Universal Serial Bus Controller**
 - USB v.1.1 and Universal Host Controller Interface (UHCI) v.1.1 compatible
 - Eighteen level (doublewords) data FIFO with full scatter and gather capability
 - Root hub and four function ports
 - Integrated physical layer transceivers with optional over-current detection status on USB inputs
 - Legacy keyboard and PS/2 mouse support

- **Sophisticated PC99-Compatible Mobile Power Management**
 - Supports both ACPI (Advanced Configuration and Power Interface) and legacy (APM) power management
 - ACPI v1.0 Compliant
 - APM v1.2 Compliant
 - CPU clock throttling and clock stop control for complete ACPI C0 to C3 state support
 - PCI bus clock run, Power Management Enable (PME) control, and PCI/CPU clock generator stop control
 - Supports multiple system suspend types: power-on suspends with flexible CPU/PCI bus reset options, suspend to DRAM, and suspend to disk (soft-off), all with hardware automatic wake-up
 - Multiple suspend power plane controls and suspend status indicators
 - One idle timer, one peripheral timer and one general purpose timer, plus 24/32-bit ACPI compliant timer
 - Normal, doze, sleep, suspend and conserve modes
 - Global and local device power control
 - System event monitoring with two event classes
 - Primary and secondary interrupt differentiation for individual channels
 - Dedicated input pins for power and sleep buttons, external modem ring indicator, and notebook lid open/close for system wake-up
 - 32 general purpose input ports and 32 output ports
 - Multiple internal and external SMI sources for flexible power management models
 - Enhanced integrated real time clock (RTC) with date alarm, month alarm, and century field
 - Thermal alarm on external temperature sensing circuit
 - I/O pad leakage control
- **Plug and Play Controller**
 - PCI interrupts steerable to any interrupt channel
 - Steerable interrupts for integrated peripheral controllers: USB, floppy, serial, parallel, and audio
 - Microsoft Windows 98™, Windows NT™, Windows 95™ and plug and play BIOS compliant
- **Built-in NAND-tree pin scan test capability**
- **0.35um, 3.3V, low power CMOS process**
- **Single chip 27x27 mm, 376 pin BGA with 1.27 mm ball pitch**

OVERVIEW

The VT8233A South Bridge is a high integration, high performance, power-efficient, and high compatibility device that supports Intel and non-Intel based processor to V-Link bus bridge functionality to make a complete Microsoft PC99-compliant PCI/ISA system. In addition to complete ISA extension bus functionality, the VT8233A includes standard intelligent peripheral controllers:

- a) Master mode enhanced IDE controller with dual channel DMA engine and interlaced dual channel commands. Dedicated FIFO coupled with scatter and gather master mode operation allows high performance transfers between PCI and IDE devices. In addition to standard PIO and DMA mode operation, the VT8233A also supports the UltraDMA-133, 100, 66, and 33 standards to allow reliable data transfer rates up to 133 MB/sec throughput. The IDE controller is SFF-8038i v1.0 and Microsoft Windows-family compliant.
- b) Universal Serial Bus controller that is USB v1.1 and Universal Host Controller Interface (UHCI) v1.1 compliant. The VT8233A includes the root hub with four function ports with integrated physical layer transceivers. The USB controller allows hot plug and play and isochronous peripherals to be inserted into the system with universal driver support. The controller also implements legacy keyboard and mouse support so that legacy software can run transparently in a non-USB-aware operating system environment.
- c) Keyboard controller with PS2 mouse support.
- d) Real Time Clock with 256 byte extended CMOS. In addition to the standard ISA RTC functionality, the integrated RTC also includes the date alarm, century field, and other enhancements for compatibility with the ACPI standard.
- e) Notebook-class power management functionality compliant with ACPI and legacy APM requirements. Multiple sleep states (power-on suspend, suspend-to-DRAM, and suspend-to-Disk) are supported with hardware automatic wake-up. Additional functionality includes event monitoring, CPU clock throttling and stop (Intel processor protocol), PCI bus clock stop control, modular power, clock and leakage control, hardware-based and software-based event handling, general purpose I/O, chip select and external SMI.
- f) Full System Management Bus (SMBus) interface.
- g) Integrated bus-mastering dual full-duplex direct-sound AC97-link-compatible sound system.
- h) Plug and Play controller that allows complete steerability of all PCI interrupts and internal interrupts / DMA channels to any interrupt channel. One additional steerable interrupt channel is provided to allow plug and play and reconfigurability of on-board peripherals for Windows family compliance.

The VT8233A also enhances the functionality of the standard ISA peripherals. The integrated interrupt controller supports both edge and level triggered interrupts channel by channel. The integrated DMA controller supports type F DMA in addition to standard ISA DMA modes. Compliant with the PCI-2.2 specification, the VT8233A supports delayed transactions and remote power management so that slower ISA peripherals do not block the traffic of the PCI bus. Special circuitry is built in to allow concurrent operation without causing dead lock even in a PCI-to-PCI bridge environment. The chip also includes eight levels (doublewords) of line buffers from the PCI bus to the ISA bus to further enhance overall system performance.

Differences Between the VT8233 (Version CE), VT8233C, and VT8233A

There are three “flavors” of the VT8233 South Bridge available from VIA: the “original” VT8233 (the latest “CE” version is described by a separate data sheet), the VT8233C (described in a separate data sheet), and the VT8233A (described by this document). These parts have similar base functionality and can be used (as long as certain rules are followed) interchangeably in the same board designs (accounting for the feature differences between the chips). The VT8233 integrates a VIA LAN subsystem, the VT8233C integrates a 3COM LAN subsystem, and the VT8233A has no LAN subsystem (the LAN pins are no connects). Otherwise, all three parts have identical pinouts except for some General Purpose I/O pins (in the VT8233C, GPIO 8-15 pin functions are not available as these pins were redefined as external PHY control, MAC clock, and alert input functions). Also, in the VT8233C, SMB port 2 is dedicated for use with the 3Com LAN subsystem, so GPIO functions on those pins available in the VT8233 were removed in the VT8233C. The VT8233A (the part described in this document) is the same as the VT8233 (CE Version) with the following exceptions: the LAN subsystem is not implemented, there are 4 USB ports instead of 6, and there are various register differences (register differences from the VT8233 “CE” part are indicated in this document). Designs that are intended to allow alternate use of any of the three parts should take these differences into account.

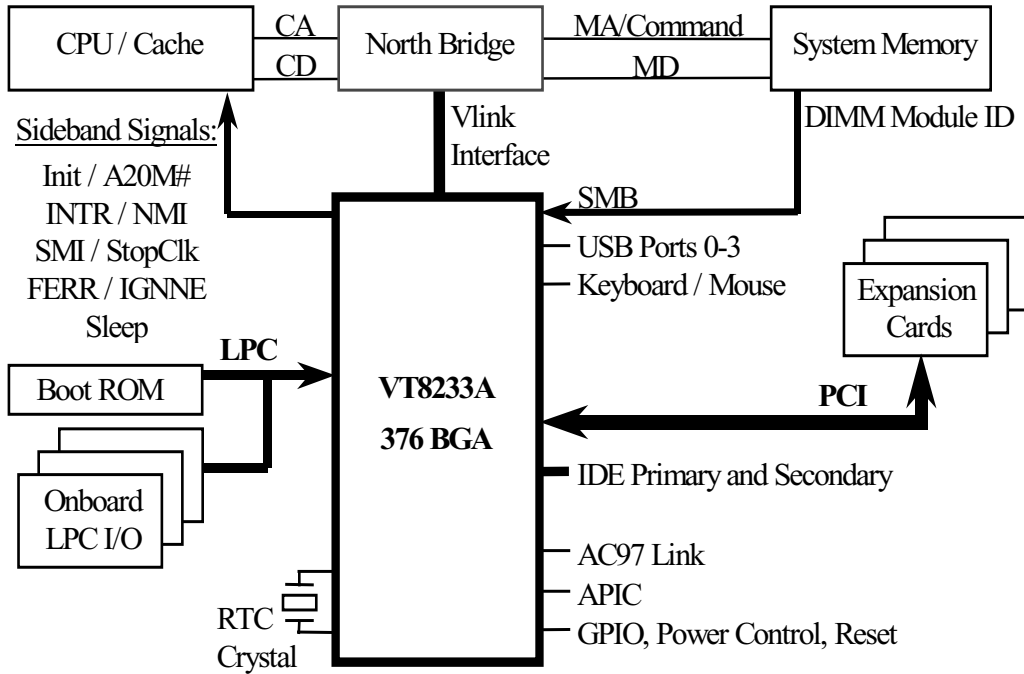

Figure 1. PC System Configuration Using the VT8233A

PINOUTS

Pin Diagram

Figure 2. VT8233A Ball Diagram (Top View)

Key	1	2	3	4	5	6	7	8	9	10	11	12	13	14	15	16	17	18	19	20	
A	VCC 33	CBE 0#	SERR#	T RDY#	CBE 2#	AD18	GPIO 8	GPIO 14	GPIO 11	VCC 33	NC	NC	NC	NC	NC	NC	USB P2+	USB P3+	USB P0+	VCC 25	
B	VCC 33	AD8	AD9	DEV SEL#	FRM#	AD17	GPIO 10	GPIO 15	GPIO 13	NC	NC	NC	NC	NC	USB OC2#	NC	USB P2-	USB P1-	USB P0-	VCC 25	
C	AD4	AD6	AD7	AD10	I RDY#	AD16	AD19	GPIO9 VRDS	GPIO 12	NC	NC	NC	NC	NC	USB OC3#	USB OC1#	NC	USB P3-	VAD 8	VAD 12	VAD 0
D	AD0	AD2	AD5	AD13	STOP#	GNT 4#	GNT 0#	REQ 1#	NC	NC	NC	NC	NC	NC	NC	USB OC0#	VCC 33	USB P1+	VAD 11	VAD 9	VAD 1
E	AD21	AD1	AD3	AD11	CBE 1#	PAR	REQ 4#	GNT 1#	NC	NC	NC	NC	NC	NC	USB GND	USB GND	USB CLK	VAD 3	VAD 5	V BE0#	UP CMD
F	AD23	AD22	AD20	AD12	AD14	AD15	VCC 33	REQ 0#	NC	NC	NC	NC	NC	NC	USB VCC	USB VCC	GND	UP STB	UP STB#	DN STB	DN STB#
G	AD25	AD24	CBE 3#	REQ 3#	INT A#	GND	VCC 33	VCC	GND	GND	VCC 33	GND	VCC	VCC 33	GND	VL VREF	DN CMD	V PAR	V BE1#	VAD 2	
H	AD28	AD26	AD27	PCI RST#	VCC 33	VCC 33	H7	8	9	10	11	12	13	H14	VCC 25	VAD 4	VAD 6	VAD 7	VAD 10	VAD 13	
J	AD30	AD31	AD29	REQ 2#	INT B#	VCC	J	GND	GND	GND	GND	GND	GND	J	VCC	VCC VK	VL COMP	VAD 14	VCC 25	VCC 25	
K	VCC 33	INT D#	GNT 2#	INT C#	GNT 3#	GND	K	GND	GND	GND	GND	GND	GND	K	VCC 25	V CLK	VAD 15	SMI#	SLP#	TPO	
L	AC BTCK	AC SDO	SDI3 AGBZ	AC RST#	VCC 33	VCC 33	L	GND	GND	GND	GND	GND	GND	L	GND	PLL VCC	PCI CLK	NMI	IGN NE#	INIT#	
M	SDI2 VGT	MS DT	AC SDI0	AC SDI1	AC SYNC	VCC	M	GND	GND	GND	GND	GND	GND	M	VCC	PLL GND	APIC D0	A20 M#	STP CLK#	VCC 33	
N	KB CK	KB DT	MS CK	RING#	VSUS 33	GND	N7	8	9	10	11	12	13	N14	VCC 33	APIC CLK	APIC D1	F ERR#	PD CS1#	INTR	
P	SUS ST1#	PME#	CPU MISS	GPO 0	VSUS 33	GND	VCC 33	VCC	GND	VCC 33	GND	VCC 33	VCC	GND	GND	VCC 33	PD DRQ	PD A2	PD CS3#	PD A0	
R	BAT LOW#	THRM #	SUS CLK	LID#	VSUS 33	VSUS 33	VCC 33	IO RDY	IO R#	SA 19	XD3	VCC 33	SD IOW#	VCC 33	GND	PD DAK#	PD A1	PD D14	PD D0	PD D15	
T	EXT SMI#	SUS A#	SMB CK1	SUS C#	PWR GD	GPIO C	IO W#	TEST	OSC	XD1	XD2	SD D11	SD D10	SD DAK#	IRQ 15	PD IOW#	PD IOR#	VCC 33	PD D13	PD D1	
U	GPI 1	SMB ALT#	SMB DT1	PWR BTN#	RSM RST#	IO31 VSEL	L REQ#	SA 18	XD5	XD4	SD DRQ	SD D8	SD D9	SD IOR#	SD A1	IRQ 14	PD D10	PD D3	PD D2	PD D12	
V	SMB DT2	SMB CK2	PWR OK#	GPIO A	PCK RUN#	PCI STP#	L AD1	MEM W#	SOE#	XD7	XD6	SD D1	SD D4	SD D7	SD D14	SD A2	PD D7	PD RDY	PD D11	PD D5	
W	VCC 33	SUS B#	INT RUD#	V BAT	IO30 GHI	L FRM#	L AD2	SER IRQ	SA 16	ROM CS#	XD0	SD D0	SD D3	SD D6	SD D13	SD A0	SD CS3#	PD D6	PD D4	VCC 33	
Y	VCC 33	GPI 0	RTC X2	RTC X1	CPU STP#	L AD3	L AD0	SPKR	SA 17	MEM R#	VCC 33	SD RDY	SD D2	SD D5	SD D12	SD D15	SD CS1#	PD D8	PD D9	VCC 33	
	1	2	3	4	5	6	7	8	9	10	11	12	13	14	15	16	17	18	19	20	

Note: Some of the pins above have alternate functions and alternate names. The table above contains only one name (usually the most often used function), but the pin lists and pin descriptions contain all names.

Pin Lists
Table 1. VT8233A Pin List (Numerical Order)

Pin	Pin Name	Pin	Pin Name	Pin	Pin Name	Pin	Pin Name	Pin	Pin Name
A01	P VCC33	D12	- NC	H03	IO AD27	P02	I PME# / GPI6	U13	IO SDD09 / SA09
A02	IO CBE0#	D13	- NC	H04	O PCIRST#	P03	I CPUMISS / GPI17	U14	O SDIOR#
A03	I SERR#	D14	- NC	H05	P VCC33	P04	OD GPO0	U15	O SDA1
A04	IO TRDY#	D15	I USB0C0#	H06	P VCC33	P05	P VSUS33	U16	I IRQ14
A05	IO CBE2#	D16	P VCC33	H15	P VCC25	P06	P GND	U17	IO PDD10
A06	IO AD18	D17	IO USBP1+	H16	IO VAD04	P07	P VCC33	U18	IO PDD03
A07	IO GPIO8	D18	IO VAD11	H17	IO VAD06	P08	P VCC	U19	IO PDD02
A08	IO GPIO14	D19	IO VAD09	H18	IO VAD07	P09	P GND	U20	IO PDD12
A09	IO GPIO11	D20	IO VAD01	H19	IO VAD10	P10	P VCC33	V01	IO SMBDT2 / IO26
A10	P VCC33	E01	IO AD21	H20	IO VAD13	P11	P GND	V02	IO SMBCK2 / IO27
A11	- NC	E02	IO AD01	J01	IO AD30	P12	P VCC33	V03	O PWROK#
A12	- NC	E03	IO AD03	J02	IO AD31	P13	P VCC	V04	IO GPIOA / GPIO24
A13	- NC	E04	IO AD11	J03	IO AD29	P14	P GND	V05	IO PCKRUN#
A14	- NC	E05	IO CBE1#	J04	I REQ2#	P15	P GND	V06	O PCISTP# / GPO6
A15	- NC	E06	IO PAR	J05	I INTB#	P16	P VCC33	V07	IO LAD1
A16	- NC	E07	I REQ4#	J06	P VCC	P17	I PDDRQ	V08	IO MEMW#
A17	IO USBP2+	E08	O GNT1#	J15	P VCC	P18	O PDA2	V09	O SOE# / strap
A18	IO USBP3+	E09	- NC	J16	P VCCVK	P19	O PDCS3#	V10	IO XD07
A19	IO USBP0+	E10	- NC	J17	I VLCOMP	P20	O PDA0	V11	IO XD06
A20	P VCC25	E11	- NC	J18	IO VAD14	R01	I BATLOW# / GPI5	V12	IO SDD01 / SA01
B01	P VCC33	E12	- NC	J19	P VCC25	R02	I THRM# / I18 / AOLGPI	V13	IO SDD04 / SA04
B02	IO AD08	E13	- NC	J20	P VCC25	R03	O SUSCLK / GPO4	V14	IO SDD07 / SA07
B03	IO AD09	E14	P USBGND	K01	P VCC33	R04	I LID# / GPI4	V15	IO SDD14 / SA14
B04	IO DEVSEL#	E15	P USBGND	K02	I INTD#	R05	P VSUS33	V16	O SDA2
B05	IO FRAME#	E16	I USBCLK	K03	O GNT2#	R06	P VSUS33	V17	IO PDD07
B06	IO AD17	E17	IO VAD03	K04	I INTC#	R07	P VCC33	V18	I PDRDY
B07	IO GPIO10	E18	IO VAD05	K05	O GNT3#	R08	I IORDY / GPI19	V19	IO PDD11
B08	IO GPIO15	E19	IO VBE0#	K06	P GND	R09	IO IOR# / GPIO22	V20	IO PDD05
B09	IO GPIO13	E20	O UPCMD	K15	P VCC25	R10	IO SA19 / O19 / strap	W01	P VCC33
B10	- NC	F01	IO AD23	K16	I VCLK	R11	IO XD03	W02	O SUSB# / GPO2
B11	- NC	F02	IO AD22	K17	IO VAD15	R12	P VCC33	W03	I INTRUD# / GPI16
B12	- NC	F03	IO AD20	K18	OD SMI#	R13	O SDIOW#	W04	P VBAT
B13	- NC	F04	IO AD12	K19	OD SLP# / GPO7	R14	P VCC33	W05	IO GPIOD/30/GHI
B14	- NC	F05	IO AD14	K20	I WSC# / APICRO#	R15	P GND	W06	IO LFRM#
B15	I USB0C2#	F06	IO AD15	L01	I ACBITCLK	R16	O PDDACK#	W07	IO LAD2
B16	- NC	F07	P VCC33	L02	O ACSDOU	R17	O PDA1	W08	I SERIRQ
B17	IO USBP2-	F08	I REQ0#	L03	I ACSDI3 / IO21 / P1# / ABZ / SB#	R18	IO PDD14	W09	IO SA16 / O16 / strap
B18	IO USBP1-	F09	P NC	L04	O ACRST#	R19	IO PDD00	W10	O ROMCS# / strap
B19	IO USBP0-	F10	P NC	L05	P VCC33	R20	IO PDD15	W11	IO XD00
B20	P VCC25	F11	P NC	L06	P VCC33	T01	IOD EXTSMI# / GPI2	W12	IO SDD00 / SA00
C01	IO AD04	F12	P NC	L15	P GND	T02	O SUSA# / GPO1	W13	IO SDD03 / SA03
C02	IO AD06	F13	P NC	L16	P PLLVCC	T03	IO SMBCK1	W14	IO SDD06 / SA06
C03	IO AD07	F14	P USBVCC	L17	I PCICLK	T04	O SUSC#	W15	IO SDD13 / SA13
C04	IO AD10	F15	P USBVCC	L18	OD NMI	T05	I PWRGD	W16	O SDA0
C05	IO IRDY#	F16	P GND	L19	OD IGNNE#	T06	IO GPIOC / GPIO25	W17	O SDCS3#
C06	IO AD16	F17	O UPSTB	L20	OD INIT#	T07	IO IOW# / GPIO23	W18	IO PDD06
C07	IO AD19	F18	O UPSTB#	M01	I ACSDI2 / IO20 / P0# / VGATE	T08	I TEST	W19	IO PDD04
C08	IO GPIO9 / VDS	F19	I DNSTB	M02	IO MSDT / IRQ12	T09	I OSC	W20	P VCC33
C09	IO GPIO12	F20	I DNSTB#	M03	I ACSDIN0	T10	IO XD01	Y01	P VCC33
C10	- NC	G01	IO AD25	M04	I ACSDIN1	T11	IO XD02	Y02	I GPIO
C11	- NC	G02	IO AD24	M05	O ACSYNC	T12	IO SDD11 / SA11	Y03	O RTCX2
C12	- NC	G03	IO CBE3#	M06	P VCC	T13	IO SDD10 / SA10	Y04	I RTCX1
C13	- NC	G04	I REQ3#	M15	P VCC	T14	O SDDACK#	Y05	O CPUSTP# / GPO5
C14	I USB0C3#	G05	I INTA#	M16	P PLLGND	T15	I IRQ15	Y06	IO LAD3
C15	I USB0C1#	G06	P GND	M17	O APICD0 / GPIO28	T16	O PDIOW#	Y07	IO LAD0
C16	- NC	G07	P VCC33	M18	OD A20M#	T17	O PDIOR#	Y08	O SPKR / strap
C17	IO USBP3-	G08	P VCC	M19	OD STPCLK#	T18	P VCC33	Y09	IO SA17 / O17 / strap
C18	IO VAD08	G09	P GND	M20	P VCC33	T19	IO PDD13	Y10	IO MEMR#
C19	IO VAD12	G10	P GND	N01	IO KBCK / A20G	T20	IO PDD01	Y11	P VCC33
C20	IO VAD00	G11	P VCC33	N02	IO KBDT / KBRC	U01	I GPI1	Y12	I SDRDY
D01	IO AD00	G12	P GND	N03	IO MSCK / IRQ1	U02	I SMBALRT# / I7	Y13	IO SDD02 / SA02
D02	IO AD02	G13	P VCC	N04	I RING# / GPI3	U03	IO SMBDT1	Y14	IO SDD05 / SA05
D03	IO AD05	G14	P VCC33	N05	P VSUS33	U04	I PWRBTN#	Y15	IO SDD12 / SA12
D04	IO AD13	G15	P GND	N06	P GND	U05	I RSMRST#	Y16	IO SDD15 / SA15
D05	IO STOP#	G16	P VLVREF	N15	P VCC33	U06	IO GPIOE/31 / VIDSEL	Y17	O SDCS1#
D06	O GNT4#	G17	I DNCMD	N16	I APICCLK	U07	IO LREQ#	Y18	IO PDD08
D07	O GNT0#	G18	IO VPAR	N17	O APICD1 / GPIO29	U08	IO SA18 / O18 / strap	Y19	IO PDD09
D08	I REQ1#	G19	IO VBE1#	N18	I FERR#	U09	IO XD05	Y20	P VCC33
D09	- NC	G20	IO VAD02	N19	O PDCS1#	U10	IO XD04		
D10	- NC	H01	IO AD28	N20	OD INTR	U11	I SDDRQ		
D11	- NC	H02	IO AD26	P01	O SUSST1# / GPO3	U12	IO SDD08 / SA08		

Center GND pins (24 pins): J8-J13, K8-K13, L8-L13, M8-M13

Table 2. VT8233A Pin List (Alphabetical Order)

Pin	Pin Name	Pin	Pin Name	Pin	Pin Name	Pin	Pin Name	Pin	Pin Name
M18	OD A20M#	P15	P GND	D14	- NC	Y13	IO SDD02 / SA02	H19	IO VAD10
L01	I ACBITCLK	R15	P GND	E09	- NC	W13	IO SDD03 / SA03	D18	IO VAD11
L04	O ACRST#	D07	O GNT0#	E10	- NC	V13	IO SDD04 / SA04	C19	IO VAD12
M03	I ACSDIN0	E08	O GNT1#	E11	- NC	Y14	IO SDD05 / SA05	H20	IO VAD13
M04	I ACSDIN1	K03	O GNT2#	E12	- NC	W14	IO SDD06 / SA06	J18	IO VAD14
M01	I ACSDI2/IO20/P0#/VGATE	K05	O GNT3#	E13	- NC	V14	IO SDD07 / SA07	K17	IO VAD15
L03	I ACSDI3/IO21/P1#/ABZ/SB#	D06	O GNT4#	F09	- NC	U12	IO SDD08 / SA08	W04	P VBAT
L02	O ACSDOUT	Y02	I GPIO	F10	- NC	U13	IO SDD09 / SA09	E19	IO VBE0#
M05	O ACSYNC	U01	I GPI1	F11	- NC	T13	IO SDD10 / SA10	G19	IO VBE1#
D01	IO AD00	A07	IO GPIO8	F12	- NC	T12	IO SDD11 / SA11	G08	P VCC
E02	IO AD01	C08	IO GPIO9 / VRDPSLP	F13	- NC	Y15	IO SDD12 / SA12	G13	P VCC
D02	IO AD02	B07	IO GPIO10	L18	OD NMI	W15	IO SDD13 / SA13	J06	P VCC
E03	IO AD03	A09	IO GPIO11	T09	I OSC	V15	IO SDD14 / SA14	J15	P VCC
C01	IO AD04	C09	IO GPIO12	E06	IO PAR	Y16	IO SDD15 / SA15	M06	P VCC
D03	IO AD05	B09	IO GPIO13	V05	IO PCKRUN#	T14	O SDDACK#	M15	P VCC
C02	IO AD06	A08	IO GPIO14	L17	I PCICLK	U11	I SDDRO	P08	P VCC
C03	IO AD07	B08	IO GPIO15	H04	O PCIRST#	U14	O SDIOR#	P13	P VCC
B02	IO AD08	V04	IO GPIOA / GPIO24	V06	O PCISTP# / GPO6	R13	O STPCLK#	A20	P VCC25
B03	IO AD09	T06	IO GPIOC / GPIO25	P20	O PDA0	Y12	I SDRDY	B20	P VCC25
C04	IO AD10	W05	IO GPIOD/30/GHI	R17	O PDA1	W08	I SERIRQ	H15	P VCC25
E04	IO AD11	U06	IO GPIOE/31/VIDSEL	P18	O PDA2	A03	I SERR#	J19	P VCC25
F04	IO AD12	P04	OD GPO0	N19	O PDCS1#	K19	OD SLP# / GPO7	J20	P VCC25
D04	IO AD13	L19	OD IGNNE#	P19	O PDCS3#	U02	I SMBALRT# / I7	K15	P VCC25
F05	IO AD14	L20	OD INIT#	R19	IO PDD00	T03	IO SMBCK1	A01	P VCC33
F06	IO AD15	G05	I INTA#	T20	IO PDD01	V02	IO SMBCK2 / IO27	A10	P VCC33
C06	IO AD16	J05	I INTB#	U19	IO PDD02	U03	IO SMBDT1	B01	P VCC33
B06	IO AD17	K04	I INTC#	U18	IO PDD03	V01	IO SMBDT2 / IO26	D16	P VCC33
A06	IO AD18	K02	I INTD#	W19	IO PDD04	K18	OD SMI#	F07	P VCC33
C07	IO AD19	N20	OD INTR	V20	IO PDD05	V09	O SOE# / strap	G07	P VCC33
F03	IO AD20	W03	I INTRUD# / GPI16	W18	IO PDD06	Y08	O SPKR / strap	G11	P VCC33
E01	IO AD21	R09	IO IOR# / GPIO22	V17	IO PDD07	D05	IO STOP#	G14	P VCC33
F02	IO AD22	R08	I IORDY / GPI19	Y18	IO PDD08	M19	OD STPCLK#	H05	P VCC33
F01	IO AD23	T07	IO IOW# / GPIO23	Y19	IO PDD09	T02	O SUSA# / GPO1	H06	P VCC33
G02	IO AD24	C05	IO IRDY#	U17	IO PDD10	W02	O SUBS# / GPO2	K01	P VCC33
G01	IO AD25	U16	I IRO14	V19	IO PDD11	T04	O SUSC#	L05	P VCC33
H02	IO AD26	T15	I IRO15	U20	IO PDD12	R03	O SUSCLK / GPO4	L06	P VCC33
H03	IO AD27	N01	IO KBCK / A20G	T19	IO PDD13	P01	O SUSST1# / GPO3	M20	P VCC33
H01	IO AD28	N02	IO KBDT / KBRC	R18	IO PDD14	T08	I TEST	N15	P VCC33
J03	IO AD29	Y07	IO LAD0	R20	IO PDD15	R02	I THRM#/GPI18	P07	P VCC33
J01	IO AD30	V07	IO LAD1	R16	O PDDACK#	K20	O TPO	P10	P VCC33
J02	IO AD31	W07	IO LAD2	P17	I PDDR0	A04	IO TRDY#	P12	P VCC33
N16	I APICCLK	Y06	IO LAD3	T17	O PDIOR#	E20	O UPCMD	P16	P VCC33
M17	O APICD0 / GPIO28	W06	IO LFRM#	T16	O PDIOW#	F17	O UPSTB	R07	P VCC33
N17	O APICD1 / GPIO29	R04	I LID# / GPI4	V18	I PDRDY	F18	O UPSTB#	R12	P VCC33
R01	I BATLOW# / GPI5	U07	IO LREQ#	M16	P PLLGND	E16	I USBCLK	R14	P VCC33
A02	IO CBE0#	Y10	IO MEMR#	L16	P PLLVCC	E14	P USBGND	T18	P VCC33
E05	IO CBE1#	V08	IO MEMW#	P02	I PME# / GPI6	E15	P USBGND	W01	P VCC33
A05	IO CBE2#	N03	IO MSCK / IRO1	U04	I PWRBTN#	D15	I USBOC0#	W20	P VCC33
G03	IO CBE3#	M02	IO MSDT / IRO12	T05	I PWRGD	C15	I USBOC1#	Y01	P VCC33
P03	I CPUMISS / GPI17	A11	- NC	V03	O PWROK#	B15	I USBOC2#	Y11	P VCC33
Y05	O CPUSTP# / GPO5	A12	- NC	F08	I REO0#	C14	I USBOC3#	Y20	P VCC33
B04	IO DEVSEL#	A13	- NC	D08	I REO1#	B19	IO USBP0-	J16	P VCCVK
G17	I DNCMD	A14	- NC	J04	I REO2#	A19	IO USBP0+	K16	I VCLK
F19	I DNSTB	A15	- NC	G04	I REO3#	B18	IO USBP1-	J17	I VLCOMP
F20	I DNSTB#	A16	- NC	E07	I REO4#	D17	IO USBP1+	G16	P VLVREF
T01	IOD EXTSMI# / GPI2	B10	- NC	N04	I RING# / GPI3	B17	IO USBP2-	G18	IO VPAR
N18	I FERR#	B11	- NC	W10	O ROMCS# / strap	A17	IO USBP2+	N05	P VSUS33
B05	IO FRAME#	B12	- NC	U05	I RSMRST#	C17	IO USBP3-	P05	P VSUS33
F16	P GND	B13	- NC	Y04	I RTCX1	A18	IO USBP3+	R05	P VSUS33
G06	P GND	B14	- NC	Y03	O RTCX2	F14	P USBVCC	R06	P VSUS33
G09	P GND	B16	- NC	W09	IO SA16 / O16 /strap	F15	P USBVCC	W11	IO XD00
G10	P GND	C10	- NC	Y09	IO SA17 / O17 /strap	C20	IO VAD00	T10	IO XD01
G12	P GND	C11	- NC	U08	IO SA18 / O18 /strap	D20	IO VAD01	T11	IO XD02
G15	P GND	C12	- NC	R10	IO SA19 / O19 /strap	G20	IO VAD02	R11	IO XD03
K06	P GND	C13	- NC	W16	O SDA0 / strap	E17	IO VAD03	U10	IO XD04
L15	P GND	C16	- NC	U15	O SDA1 / strap	H16	IO VAD04	U09	IO XD05
N06	P GND	D09	- NC	V16	O SDA2 / strap	E18	IO VAD05	V11	IO XD06
P06	P GND	D10	- NC	Y17	O SDCS1#	H17	IO VAD06	V10	IO XD07
P09	P GND	D11	- NC	W17	O SDCS3#	H18	IO VAD07		
P11	P GND	D12	- NC	W12	IO SDD00 / SA00	C18	IO VAD08		
P14	P GND	D13	- NC	V12	IO SDD01 / SA01	D19	IO VAD09		

 Center **GND** pins (24 pins): J8-J13, K8-K13, L8-L13, M8-M13

PIN DESCRIPTIONS

Table 3. Pin Descriptions

V-Link Interface			
Signal Name	Pin #	I/O	Signal Description
VAD[15:0]	K17, J18, H20, C19, D18, H19, D19, C18, H18, H17, E18, H16, E17, G20, D20, C20	IO	Address / Data Bus. Bits 0-7 are implemented and bits 8-15 are reserved for future use. VAD[6:0] are used to send strap information to the chipset north bridge. At power up VAD[6:4] reflect the state of straps on pins SDA[2:0] and VAD[3:0] reflect the state of straps on pins SA[19:16]. The specific interpretation of these straps is north bridge chip design dependent.
VPAR	G18	IO	Parity.
VBE[1:0]#	G19, E19	IO	Byte Enables. VBE0# is used with VAD[7-0] and VBE1# is used with VAD[15-8] (VBE1# and VAD[15-8] are reserved for future use).
VCLK	K16	I	V-Link Clock.
UPCMD	E20	O	Command from Client-to-Host.
DNCMD	G17	I	Command from Host-to-Client.
UPSTB	F17	O	Strobe from Client-to-Host.
UPSTB#	F18	O	Complement Strobe from Client-to-Host.
DNSTB	F19	I	Strobe from Host-to-Client.
DNSTB#	F20	I	Complement Strobe from Host-to-Client.
VLVREF	G16	I	Voltage Reference.
VLCOMP	J17	I	V-Link Compensation.
VCCVK	J16	P	V-Link Compensation Circuit Voltage.

Advanced Programmable Interrupt Controller (APIC) Interface			
Signal Name	Pin #	I/O	Signal Description
APICD1 / GPI29 / GPO29	N17	O	Internal APIC Data 1.
APICD0 / GPI28 / GPO28	M17	O	Internal APIC Data 0.
APICCLK	N16	I	APIC Clock.

Straps			
Signal Name	Pin #	I/O	Signal Description
Strap / SDA2	V16	I	Strap. State reflected on VAD[6] at powerup. No internal function.
Strap / SDA1	U15	I	Strap. State reflected on VAD[5] at powerup. No internal function.
Strap / SDA0	W16	I	Strap. State reflected on VAD[4] at powerup. No internal function.
Strap / SA19	R10	I	Strap. State reflected on VAD[3] at powerup. No internal function.
Strap / SA18	U8	I	Strap. State reflected on VAD[2] at powerup. No internal function.
Strap / SA17	Y9	I	Strap. State reflected on VAD[1] at powerup. No internal function.
Strap / SA16	W9	I	Strap. State reflected on VAD[0] at powerup. No internal function.
Strap / SOE#	V9	I	Strap. Strap low to enable (high to disable) auto reboot.
Strap / SPKR	Y8	I	Strap. Strap low to enable (high to disable) CPU frequency strapping
Strap / ROMCS# / KBCS#	W10	I	Strap. Strap high to enable LPC BIOS ROM

CPU Interface			
Signal Name	Pin #	I/O	Signal Description
A20M#	M18	OD	A20 Mask. Connect to A20 mask input of the CPU to control address bit-20 generation. Logical combination of the A20GATE input (from internal or external keyboard controller) and Port 92 bit-1 (Fast_A20).
FERR#	N18	I	Numerical Coprocessor Error. This signal is tied to the coprocessor error signal on the CPU. Internally generates interrupt 13 if active. Output voltage swing is programmable tot 1.5V or 2.5V by Device 17 Function 0 Rx67[2].
IGNNE#	L19	OD	Ignore Numeric Error. This pin is connected to the CPU "ignore error" pin.
INIT#	L20	OD	Initialization. The VT8233A asserts INIT# if it detects a shut-down special cycle on the PCI bus or if a soft reset is initiated by the register
INTR	N20	OD	CPU Interrupt. INTR is driven by the VT8233A to signal the CPU that an interrupt request is pending and needs service.
NMI	L18	OD	Non-Maskable Interrupt. NMI is used to force a non-maskable interrupt to the CPU. The VT8233A generates an NMI when PCI bus SERR# is asserted.
SLP# / GPO7	K19	OD	Sleep. Used to put the CPU to sleep.
SMI#	K18	OD	System Management Interrupt. SMI# is asserted by the VT8233A to the CPU in response to different Power-Management events.
STPCLK#	M19	OD	Stop Clock. STPCLK# is asserted by the VT8233A to the CPU to throttle the processor clock.

Note: Connect each of the above signals to 150 Ω pullup resistors to VCC_CMOS (see Design Guide).

PCI Bus Interface																																	
Signal Name	Pin #	I/O	Signal Description																														
AD[31:0]	(See Pin List)	IO	Address / Data Bus. The standard PCI address and data lines. The address is driven with FRAME# assertion and data is driven or received in following cycles.																														
CBE[3:0]#	G3, A5, E5, A2	IO	Command / Byte Enable. The command is driven with FRAME# assertion. Byte enables corresponding to supplied or requested data are driven on following clocks.																														
DEVSEL#	B4	IO	Device Select. The VT8233A asserts this signal to claim PCI transactions through positive or subtractive decoding. As an input, DEVSEL# indicates the response to a VT8233A-initiated transaction and is also sampled when decoding whether to subtractively decode the cycle.																														
FRAME#	B5	IO	Frame. Assertion indicates the address phase of a PCI transfer. Negation indicates that one more data transfer is desired by the cycle initiator.																														
IRDY#	C5	IO	Initiator Ready. Asserted when the initiator is ready for data transfer.																														
TRDY#	A4	IO	Target Ready. Asserted when the target is ready for data transfer.																														
STOP#	D5	IO	Stop. Asserted by the target to request the master to stop the current transaction.																														
SERR#	A3	I	System Error. SERR# can be pulsed active by any PCI device that detects a system error condition. Upon sampling SERR# active, the VT8233A can be programmed to generate an NMI to the CPU.																														
PAR	E6	IO	Parity. A single parity bit is provided over AD[31:0] and C/BE[3:0]#.																														
INTA-D#	G5, J5, K4, K2	I	<p>PCI Interrupt Request. These pins are typically connected to the PCI bus INTA#-INTD# pins as follows:</p> <table border="0"> <tr> <td></td> <td><u>INTA#</u></td> <td><u>INTB#</u></td> <td><u>INTC#</u></td> <td><u>INTD#</u></td> </tr> <tr> <td>PCI Slot 1</td> <td>INTA#</td> <td>INTB#</td> <td>INTC#</td> <td>INTD#</td> </tr> <tr> <td>PCI Slot 2</td> <td>INTB#</td> <td>INTC#</td> <td>INTD#</td> <td>INTA#</td> </tr> <tr> <td>PCI Slot 3</td> <td>INTC#</td> <td>INTD#</td> <td>INTA#</td> <td>INTB#</td> </tr> <tr> <td>PCI Slot 4</td> <td>INTD#</td> <td>INTA#</td> <td>INTB#</td> <td>INTC#</td> </tr> <tr> <td>PCI Slot 5</td> <td>INTA#</td> <td>INTB#</td> <td>INTC#</td> <td>INTD#</td> </tr> </table>		<u>INTA#</u>	<u>INTB#</u>	<u>INTC#</u>	<u>INTD#</u>	PCI Slot 1	INTA#	INTB#	INTC#	INTD#	PCI Slot 2	INTB#	INTC#	INTD#	INTA#	PCI Slot 3	INTC#	INTD#	INTA#	INTB#	PCI Slot 4	INTD#	INTA#	INTB#	INTC#	PCI Slot 5	INTA#	INTB#	INTC#	INTD#
	<u>INTA#</u>	<u>INTB#</u>	<u>INTC#</u>	<u>INTD#</u>																													
PCI Slot 1	INTA#	INTB#	INTC#	INTD#																													
PCI Slot 2	INTB#	INTC#	INTD#	INTA#																													
PCI Slot 3	INTC#	INTD#	INTA#	INTB#																													
PCI Slot 4	INTD#	INTA#	INTB#	INTC#																													
PCI Slot 5	INTA#	INTB#	INTC#	INTD#																													
REQ[4:0]#	E7, G4, J4, D8, F8	I	PCI Request. This signal goes to the VT8233A to request the PCI bus.																														
GNT[4:0]#	D6, K5, K3, E8, D7	O	PCI Grant. This signal is driven by the VT8233A to grant PCI access.																														
PCIRST#	H4	O	PCI Reset. This signal is used to reset devices attached to the PCI bus.																														
PCICLK	L17	I	PCI Clock. This signal provides timing for all transactions on the PCI Bus.																														
PCKRUN#	V5	IO	PCI Bus Clock Run. This signal indicates whether the PCI clock is or will be stopped (high) or running (low). The VT8233A drives this signal low when the PCI clock is running (default on reset) and releases it when it stops the PCI clock. External devices may assert this signal low to request that the PCI clock be restarted or prevent it from stopping. Connect this pin to ground using a 100 Ω resistor if the function is not used. Refer to the "PCI Mobile Design Guide" and the VIA "VT8633 Apollo Pro266 Design Guide" for more details.																														

Low Pin Count (LPC) Interface			
Signal Name	Pin #	I/O	Signal Description
LFRM#	W6	IO	LPC Frame.
LREQ#	U7	IO	LPC DMA / Bus Master Request.
LAD[3-0]	Y6, W7, V7, Y7	IO	LPC Address / Data.

Note: Connect the LPC interface LPCRST# (LPC Reset) signal to PCIRST#

Universal Serial Bus Interface			
Signal Name	Pin #	I/O	Signal Description
USBP0+	A19	IO	USB Port 0 Data +
USBP0-	B19	IO	USB Port 0 Data -
USBP1+	D17	IO	USB Port 1 Data +
USBP1-	B18	IO	USB Port 1 Data -
USBP2+	A17	IO	USB Port 2 Data +
USBP2-	B17	IO	USB Port 2 Data -
USBP3+	A18	IO	USB Port 3 Data +
USBP3-	C17	IO	USB Port 3 Data -
USBCLK	E16	I	USB Clock. 48MHz clock input for the USB interface
USBOC0#	D15	I	USB Port 0 Over Current Detect. Port 0 is disabled if low.
USBOC1#	C15	I	USB Port 1 Over Current Detect. Port 1 is disabled if low.
USBOC2#	B15	I	USB Port 2 Over Current Detect. Port 2 is disabled if low.
USBOC3#	C14	I	USB Port 3 Over Current Detect. Port 3 is disabled if low.
USBVCC	F14-F15	Power	Power for USB Port Interface Logic.
USBGND	E14-E15	Power	Ground for USB Port Interface Logic.

System Management Bus (SMB) Interface (I²C Bus)			
Signal Name	Pin #	I/O	Signal Description
SMBCK1	T3	IO	SMB / I ² C Channel 1 Clock.
SMBCK2 / GPI27 / GPO27	V2	IO	SMB / I ² C Channel 2 Clock. Rx95[2] = 0
SMBDT1	U3	IO	SMB / I ² C Channel 1 Data.
SMBDT2 / GPI26 / GPO26	V1	IO	SMB / I ² C Channel 2 Data. Rx95[2] = 0
SMBALRT# / GPI7	U2	I	SMB Alert. (System Management Bus I/O space Rx08[3] = 1) When the chip is enabled to allow it, assertion generates an IRQ or SMI interrupt or a power management resume event.

Programmable Chip Selects			
Signal Name	Pin #	I/O	Signal Description
PCS0# / GPIO20 / ACSDIN2 / VGATE	M1	O	Programmable Chip Select 0. RxE4[6]=1, E5[1]=1, and E5[4]=0
PCS1# / GPIO21 / ACSDIN3 / AGPBZ# / SLPBTN#	L3	O	Programmable Chip Select 1. RxE4[6]=1, E5[2]=1, and E5[5]=0

UltraDMA-133 / 100 / 66 / 33 Enhanced IDE Interface			
Signal Name	Pin #	I/O	Signal Description
PDRDY / PDDMARDY / PDSTROBE	V18	I	EIDE Mode: Primary I/O Channel Ready. Device ready indicator UltraDMA Mode: Primary Device DMA Ready. Output flow control. The device may assert DDMARDY to pause output transfers Primary Device Strobe. Input data strobe (both edges). The device may stop DSTROBE to pause input data transfers
SDRDY / SDDMARDY / SDSTROBE	Y12	I	EIDE Mode: Secondary I/O Channel Ready. Device ready indicator UltraDMA Mode: Secondary Device DMA Ready. Output flow control. The device may assert DDMARDY to pause output transfers Secondary Device Strobe. Input data strobe (both edges). The device may stop DSTROBE to pause input data transfers
PDIOR# / PHDMARDY / PHSTROBE	T17	O	EIDE Mode: Primary Device I/O Read. Device read strobe UltraDMA Mode: Primary Host DMA Ready. Primary channel input flow control. The host may assert HDMARDY to pause input transfers Primary Host Strobe. Output data strobe (both edges). The host may stop HSTROBE to pause output data transfers
SDIOR# / SHDMARDY / SHSTROBE	U14	O	EIDE Mode: Secondary Device I/O Read. Device read strobe UltraDMA Mode: Secondary Host DMA Ready. Input flow control. The host may assert HDMARDY to pause input transfers Host Strobe B. Output strobe (both edges). The host may stop HSTROBE to pause output data transfers
PDIOW# / PSTOP	T16	O	EIDE Mode: Primary Device I/O Write. Device write strobe UltraDMA Mode: Primary Stop. Stop transfer: Asserted by the host prior to initiation of an UltraDMA burst; negated by the host before data is transferred in an UltraDMA burst. Assertion of STOP by the host during or after data transfer in UltraDMA mode signals the termination of the burst.
SDIOW# / SSTOP	R13	O	EIDE Mode: Secondary Device I/O Write. Device write strobe UltraDMA Mode: Secondary Stop. Stop transfer: Asserted by the host prior to initiation of an UltraDMA burst; negated by the host before data is transferred in an UltraDMA burst. Assertion of STOP by the host during or after data transfer in UltraDMA mode signals the termination of the burst.
PDDRQ	P17	I	Primary Device DMA Request. Primary channel DMA request
SDDRQ	U11	I	Secondary Device DMA Request. Secondary channel DMA request
PDDACK#	R16	O	Primary Device DMA Acknowledge. Primary channel DMA acknowledge
SDDACK#	T14	O	Secondary Device DMA Acknowledge. Secondary channel DMA acknowledge
IRQ14	U16	I	Primary Channel Interrupt Request.
IRQ15	T15	I	Secondary Channel Interrupt Request.

UltraDMA-133 / 100 / 66 / 33 Enhanced IDE Interface (continued)			
Signal Name	Pin #	I/O	Signal Description
PDCS1#	N19	O	Primary Master Chip Select. This signal corresponds to CS1FX# on the primary IDE connector.
PDCS3#	P19	O	Primary Slave Chip Select. This signal corresponds to CS3FX# on the primary IDE connector.
SDCS1#	Y17	O	Secondary Master Chip Select. This signal corresponds to CS17X# on the secondary IDE connector.
SDCS3#	W17	O	Secondary Slave Chip Select. This signal corresponds to CS37X# on the secondary IDE connector.
PDA[2-0]	P18, R17, P20	O	Primary Disk Address. PDA[2:0] are used to indicate which byte in either the ATA command block or control block is being accessed.
SDA[2-0] / strap	V16, U15, W16	O	Secondary Disk Address. SDA[2:0] are used to indicate which byte in either the ATA command block or control block is being accessed. Strap information is communicated to the north bridge via VAD[6:4].
PDD[15-0]	(See Pin List)	IO	Primary Disk Data
SDD[15-0] / SA[15-0]	(See Pin List)	IO / IO	Secondary Disk Data

Serial IRQ			
Signal Name	Pin #	I/O	Signal Description
SERIRQ	W8	I	Serial IRQ

AC97 Audio / Modem Interface			
Signal Name	Pin #	I/O	Signal Description
ACRST#	L4	O	AC97 Reset.
ACBTCK	L1	I	AC97 Bit Clock.
ACSYNC	M5	O	AC97 Sync.
ACSDO	L2	O	AC97 Serial Data Out.
ACSDIN0	M3	I	AC97 Serial Data In 0.
ACSDIN1	M4	I	AC97 Serial Data In 1.
ACSDIN2 / GPIO20 / PCS0# / VGATE	M1	I	AC97 Serial Data In 2. RxE4[6]=0, E5[1]=0, & E5[4]=0
ACSDIN3 / GPIO21 / PCS1# / SLPBTN# / AGPBZ#	L3	I	AC97 Serial Data In 3. RxE4[6]=0, E5[2]=0, & E5[5]=0

Internal Keyboard Controller			
Signal Name	Pin #	I/O	Signal Description
MSCK / IRQ1	N3	IO / I	MultiFunction Pin (Internal mouse controller enabled by Rx51[1]) Rx51[1]=1 Mouse Clock . From internal mouse controller. Rx51[1]=0 Interrupt Request 1 . Interrupt input 1.
MSDT / IRQ12	M2	IO / I	MultiFunction Pin (Internal mouse controller enabled by Rx51[1]) Rx51[1]=1 Mouse Data . From internal mouse controller. Rx51[1]=0 Interrupt Request 12 . Interrupt input 12.
KBCK / KA20G	N1	IO / I	MultiFunction Pin (Internal keyboard controller enabled by Rx51[0]) Rx51[0]=1 Keyboard Clock . From internal keyboard controller Rx51[0]=0 Gate A20 . Input from external keyboard controller.
KBDT / KBRC	N2	IO / I	MultiFunction Pin (Internal keyboard controller enabled by Rx51[0]) Rx51[0]=1 Keyboard Data . From internal keyboard controller. Rx51[0]=0 Keyboard Reset . From external keyboard controller (KBC) for CPURST# generation
KBCS# / ROMCS# / strap	W10	O / O	Keyboard Chip Select (Rx51[0]=0). To external keyboard controller chip. Strap high to enable LPC ROM:

ISA Subset / Parallel BIOS ROM Interface			
Signal Name	Pin #	I/O	Signal Description
ROMCS# / KBCS# / strap	W10	O	ROM Chip Select (Rx51[0]=1). Chip Select to the BIOS ROM. Strap high to enable LPC ROM.
SPKR / strap	Y8	O	Speaker . Strap low to enable (high to disable) CPU frequency strapping.
MEMR#	Y10	O	Memory Read .
MEMW#	V8	O	Memory Write .
IOR# / GPIO22	R9	O	I/O Read . RxE4[7] = 1
IOW# / GPIO23	T7	O	I/O Write . RxE4[7] = 1
IORDY / GPI19	R8	I	I/O Ready . Used to insert wait states in I/O or memory cycles. RxE5[0] = 0
SOE# / strap	V9	O	XD Bus Tranceiver Output Enable . Strap low to enable auto reboot.
XD[7-0]	V10, V11, U9, U10, R11, T11, T10, W11	IO	XD Bus . For input of BIOS ROM data or data from other on-board I/O or memory devices.
SA[19-16] / GPO[19-16] / straps	R10, U8, Y9, W9	O	System Address 19-16 . Strap states are passed to North Bridge via VAD[3-0]. Functions as SA[19-16] if RxE4[5] = 0.
SA[15-0] / SDD[15-0]	(See Pin List)	O	System Address 15-0 .

General Purpose Inputs			
Signal Name	Pin #	I/O	Signal Description
GPI0 / <u>(VBAT)</u>	Y2	I	General Purpose Input 0. Status on PMIO Rx20[0]
GPI1 / <u>(VSUS33)</u>	U1	I	General Purpose Input 1. Status on PMIO Rx20[1]
GPI2 / EXTSMI# / <u>(VSUS33)</u>	T1	I	General Purpose Input 2. Status on PMIO Rx20[4]
GPI3 / RING# / <u>(VSUS33)</u>	N4	I	General Purpose Input 3. Status on PMIO Rx20[8]
GPI4 / LID# / <u>(VSUS33)</u>	R4	I	General Purpose Input 4. Status on PMIO Rx20[11]
GPI5 / BATLOW# / <u>(VSUS33)</u>	R1	I	General Purpose Input 5. Status on PMIO Rx20[12]
GPI6 / PME# / <u>(VSUS33)</u>	P2	I	General Purpose Input 6. Status on PMIO Rx20[5]
GPI7 / SMBALRT# / <u>(VSUS33)</u>	U2	I	General Purpose Input 7.
GPI8 / GPO8	A7	I	General Purpose Input 8. RxE4[3] = 0
GPI9 / GPO9 / <u>VRDPSLP</u>	C8	I	General Purpose Input 9. RxE4[3] = 0 & E5[3]=1
GPI10 / GPO10	B7	I	General Purpose Input 10. RxE4[3] = 0
GPI11 / GPO11	A9	I	General Purpose Input 11. RxE4[3] = 0
GPI12 / GPO12	C9	I	General Purpose Input 12. RxE4[4] = 0
GPI13 / GPO13	B9	I	General Purpose Input 13. RxE4[4] = 0
GPI14 / GPO14	A8	I	General Purpose Input 14. RxE4[4] = 0
GPI15 / GPO15	B8	I	General Purpose Input 15. RxE4[4] = 0
GPI16 / INTRUDER# / <u>(VBAT)</u>	W3	I	General Purpose Input 16. Status on PMIO Rx20[6]
GPI17 / CPUMISS	P3	I	General Purpose Input 17. Status on PMIO Rx20[5]
GPI18 / THRM#	R2	I	General Purpose Input 18. Rx8C[3] = 0
GPI19 / <u>IORDY</u>	R8	I	General Purpose Input 19. RxE5[0] = 1
GPI20 / GPO20 / <u>ACSDIN2</u> / PCS0# / VGATE	M1	I	Gen Purpose In 20. RxE4[6]=1, E5[1]=0, & PMIO 4C[20]=1
GPI21 / GPO21 / <u>ACSDIN3</u> / PCS1# / AGPBZ# / SLPBTN#	L3	I	Gen Purpose In 21. RxE4[6]=1, E5[2]=0, & PMIO 4C[21]=1
GPI22 / GPO22 / <u>IOR#</u>	R9	I	General Purpose Input 22. RxE4[7] = 0 & PMIO 4C[22]=1
GPI23 / GPO23 / <u>IOW#</u>	T7	I	General Purpose Input 23. RxE4[7] = 0 & PMIO 4C[23]=1
GPI24 / GPO24 / <u>GPIOA</u>	V4	I	General Purpose Input 24. RxE6[0] = 0
GPI25 / GPO25 / <u>GPIOC</u>	T6	I	General Purpose Input 25. RxE6[1] = 0
GPI26 / GPO26 / <u>SMBDT2</u> / <u>(VSUS33)</u>	Y2	I	General Purpose Input 26. Rx95[3] = 0
GPI27 / GPO27 / <u>SMBCK2</u> / <u>(VSUS33)</u>	T5	I	General Purpose Input 27. Rx95[3] = 0
GPI28 / GPO28 / <u>APICD0</u>	M17	I	General Purpose Input 28. Rx58[6] = 0 & PMIO 4C[28]=1
GPI29 / GPO29 / <u>APICD1</u>	N17	I	General Purpose Input 29. Rx58[6] = 0 & PMIO 4C[29]=1
GPI30 / GPO30 / <u>GPIOD</u> / <u>GHI#</u>	W5	I	General Purpose Input 30. RxE6[6] = 0 & E5[3]=1
GPI31 / GPO31 / <u>GPIOE</u> / <u>VIDSEL</u>	U6	I	General Purpose Input 31. RxE6[7] = 0 & E5[3]=1

Note: Default pin function is underlined in the signal name column above.

Note: Input pin status for the above GPI pins 31-0 is also available on PMIO (ACPI) Rx4C-48[31-0]

Note: See also Power Management I/O register Rx50 for input pin change status for GPI16-19 and 24-27

Note: See also Power Management I/O register Rx52 for SCI/SMI select for GPI16-19 and 24-27

Note: See also Power Management I/O register Rx4C. General purpose input pins 20-31 are shared with OD (open drain) general purpose output functions, so to use one of these pins as an input pin, a one must be written to the corresponding bit of PMIO (ACPI) Rx4C.

General Purpose I/O			
Signal Name	Pin #	I/O	Signal Description
<u>GPIOA</u> / <u>GPI24</u> / GPO24	V4	IO	General Purpose I/O A / 24. RxE6[0] = 1
<u>GPIOC</u> / <u>GPI25</u> / GPO25	T6	IO	General Purpose I/O C / 25.
<u>GPIOD</u> / GPI30 / GPO30 / <u>GHI#</u>	W5	IO	General Purpose I/O D / 30.
<u>GPIOE</u> / GPI31 / GPO31 / <u>VIDSEL</u>	U6	IO	General Purpose I/O E / 31.

The output type of the above pins may be selected as either OD or TTL (see Device 17 Function 0 RxE7)

General Purpose Outputs			
Signal Name	Pin #	I/O	Signal Description
<u>GPO0</u>	<i>(VSUS33)</i> P4	OD	General Purpose Output 0.
<u>GPO1</u> / <u>SUSA#</u>	<i>(VSUS33)</i> T2	O	General Purpose Output 1. Rx94[2] = 1
<u>GPO2</u> / <u>SUSB#</u>	<i>(VSUS33)</i> W2	O	General Purpose Output 2. Rx94[3] = 1
<u>GPO3</u> / <u>SUSST1#</u>	<i>(VSUS33)</i> P1	O	General Purpose Output 3. Rx94[4] = 1
<u>GPO4</u> / <u>SUSCLK</u>	<i>(VSUS33)</i> R3	O	General Purpose Output 4. Rx95[1] = 1
<u>GPO5</u> / <u>CPUSTP#</u>	Y5	O	General Purpose Output 5. RxE4[0] = 1
<u>GPO6</u> / <u>PCISTP#</u>	V6	O	General Purpose Output 6. RxE4[1] = 1
<u>GPO7</u> / <u>SLP#</u>	K19	O	General Purpose Output 7. RxE4[2] = 1
<u>GPO8</u> / <u>GPI8</u>	A7	O	General Purpose Output 8. RxE4[3]=1
<u>GPO9</u> / GPI9 / <u>VRDPSLP</u>	C8	O	General Purpose Output 9. RxE4[3]=1, E5[3] = 1
<u>GPO10</u> / <u>GPI10</u>	B7	O	General Purpose Output 10. RxE4[3]=1
<u>GPO11</u> / <u>GPI11</u>	A9	O	General Purpose Output 11. RxE4[3]=1
<u>GPO12</u> / <u>GPI12</u>	C9	O	General Purpose Output 12. RxE4[4]=1
<u>GPO13</u> / <u>GPI13</u>	B9	O	General Purpose Output 13. RxE4[4]=1
<u>GPO14</u> / <u>GPI14</u>	A8	O	General Purpose Output 14. RxE4[4]=1
<u>GPO15</u> / <u>GPI15</u>	B8	O	General Purpose Output 15. RxE4[4]=1
<u>GPO16</u> / <u>SA16</u> / strap	W9	O	General Purpose Output 16. RxE4[5] = 1
<u>GPO17</u> / <u>SA17</u> / strap	Y9	O	General Purpose Output 17. RxE4[5] = 1
<u>GPO18</u> / <u>SA18</u> / strap	U8	O	General Purpose Output 18. RxE4[5] = 1
<u>GPO19</u> / <u>SA19</u> / strap	R10	O	General Purpose Output 19. RxE4[5] = 1
<u>GPO20</u> / GPI20 / <u>ACSDIN2</u> / PCS0# / VGATE	M1	OD	General Purpose Output 20. RxE4[6] = 1, E5[1] = 0
<u>GPO21</u> / GPI21 / <u>ACSDIN3</u> / PCS1# / AGPBZ# / SLPBTN#	L3	OD	General Purpose Output 21. RxE4[6] = 1, E5[2] = 0
<u>GPO22</u> / <u>GPI22</u> / IOR#	R9	OD	General Purpose Output 22. RxE4[7] = 0
<u>GPO23</u> / <u>GPI23</u> / IOW#	T7	OD	General Purpose Output 23. RxE4[7] = 0
<u>GPO24</u> / <u>GPI24</u> / GPIOA	V4	O/OD	General Purpose Output 24. RxE6[0] = 1
<u>GPO25</u> / <u>GPI25</u> / GPIOC	T6	O/OD	General Purpose Output 25. RxE6[1] = 1
<u>GPO26</u> / GPI26 / <u>SMBDT2</u>	<i>(VSUS33)</i> Y2	OD	General Purpose Output 26. Rx95[2] = 1, 95[3] = 1
<u>GPO27</u> / GPI27 / <u>SMBCK2</u>	<i>(VSUS33)</i> T5	OD	General Purpose Output 27. Rx95[2] = 1, 95[3] = 1
<u>GPO28</u> / GPI28 / <u>APICD0</u>	M17	OD	General Purpose Output 28. Rx58[6] = 0
<u>GPO29</u> / GPI29 / <u>APICD1</u>	N17	OD	General Purpose Output 29. Rx58[6] = 0
<u>GPO30</u> / GPI30 / GPIOD / <u>GHI#</u>	W5	O/OD	General Purpose Output 30. RxE6[6] = 1, E5[3] = 1
<u>GPO31</u> / GPI31 / GPIOE / <u>VIDSEL</u>	U6	O/OD	General Purpose Output 31. RxE6[7] = 1, E5[3] = 1

Note: The output state for each of the above general purpose outputs is selectable via Power Management I/O registers Rx4C-48

Note: The output types of GPO24-25 and 30-31 are selectable OD vs TTL (see Function 0 RxE7)

Note: Default pin functions are underlined in the table above.

Power Management and Event Detection			
Signal Name	Pin #	I/O	Signal Description
PWRBTN#	U4	I	Power Button. Used by the Power Management subsystem to monitor an external system on/off button or switch.
SLPBTN# / GPIO21 / ACS DIN3 / PCS1# / AGPBZ#	L3	I	Sleep Button. Used by the Power Management subsystem to monitor an external sleep button or switch. RxE4[6] = 1 and E5[5]=0
RSMRST#	U5	I	Resume Reset. Resets the internal logic connected to the VSUS33 power plane and also resets portions of the internal RTC logic.
EXTSMI# / GPI2	T1	IO D	External System Management Interrupt. When enabled to allow it, a falling edge on this input causes an SMI# to be generated to the CPU to enter SMI mode. (10K PU to VCCS if not used) (3.3V only)
PME# / GPI6	P2	I	Power Management Event. (10K PU to VCCS if not used)
SMBALRT# / GPI7	U2	I	SMB Alert. When the chip is enabled to allow it, assertion generates an IRQ or SMI or power management event. (10K PU to VCCS if not used)
LID# / GPI4	R4	I	Notebook Computer Display Lid Open / Closed Monitor. Used by the Power Management subsystem to monitor the opening and closing of the display lid of notebook computers. Can be used to detect either low-to-high or high-to-low transitions to generate an SMI#. (10K PU to VCCS if not used)
INTRUDER# / GPI16	W3	I	Intrusion Indicator. The value of this bit may be read at PMIO Rx20[6]
THRM# / GPI18	R2	I	Thermal Alarm Monitor. Rx8C[3] = 1. Rising or falling edges (selectable by PMIO Rx2C[6]) may be detected to set status at PMIO Rx20[10]. Setting of this status bit may then be used to generate an SCI or SMI. THRM# may also be used to enable duty cycle control of stop-clock (STPCLK#) to automatically limit maximum temperature (see Device 17 Function 0 Rx8C[7-3]).
RING# / GPI3	N4	I	Ring Indicator. May be connected to external modem circuitry to allow the system to be re-activated by a received phone call. (10K PU to VCCS if not used)
BATLOW# / GPI5	R1	I	Battery Low Indicator. (10K PU to VCCS if not used) (3.3V only)
CPUSTP# / GPO5	Y5	O	CPU Clock Stop (RxE4[0] = 0). Signals the system clock generator to disable the CPU clock outputs. Not connected if not used.
PCISTP# / GPO6	V6	O	PCI Clock Stop (RxE4[1] = 0). Signals the system clock generator to disable the PCI clock outputs. Not connected if not used.
SUSA# / GPO1	T2	O	Suspend Plane A Control (Rx94[2]=0). Asserted during power management POS, STR, and STD suspend states. Used to control the primary power plane. (10K PU to VCCS if not used)
SUSB# / GPO2	W2	O	Suspend Plane B Control (Rx94[3]=0). Asserted during power management STR and STD suspend states. Used to control the secondary power plane. (10K PU to VCCS if not used)
SUSC#	T4	O	Suspend Plane C Control. Asserted during power management STD suspend state. Used to control the tertiary power plane. Also connected to ATX power-on circuitry.
SUSST1# / GPO3	P1	O	Suspend Status 1 (Rx94[4] = 0). Typically connected to the North Bridge to provide information on host clock status. Asserted when the system may stop the host clock, such as Stop Clock or during POS, STR, or STD suspend states. Connect 10K PU to VCCS.
SUSCLK	R3	O	Suspend Clock. 32.768 KHz output clock for use by the North Bridge (e.g., VT8633 or VT8366) for DRAM refresh purposes. Stopped during Suspend-to-Disk and Soft-Off modes. Connect 10K PU to VCCS.
CPUMISS / GPI17	P3	I	CPU Missing. Used to detect the physical presence of the CPU chip in its socket. High indicates no CPU present. Connect to the CPUMISS pin of the CPU socket. The state of this pin may be read in the SMBus 2 registers. This pin may be used as CPUMISS and GPI17 at the same time.

Resets, Clocks, and Power Status			
Signal Name	Pin #	I/O	Signal Description
PWRGD	T5	I	Power Good. Connected to the PWRGOOD signal on the Power Supply.
PWROK#	V3	O	Power OK.
PCIRST#	H4	O	PCI Reset. Active low reset signal for the PCI bus. The VT8233A will assert this pin during power-up or from the control register.
OSC	T9	I	Oscillator. 14.31818 MHz clock signal used by the internal Timer.
RTCX1	Y4	I	RTC Crystal Input: 32.768 KHz crystal or oscillator input. This input is used for the internal RTC and for power-well power management logic.
RTCX2	Y3	O	RTC Crystal Output: 32.768 KHz crystal output
TEST	T8	I	Test.
TPO	K20	O	Test Pin Output. Output pin for test mode.
NC	A11-A16, B10-B14, B16, C10-C13, C16, D9-D14, E9-E13, F9-F13	P	No Connect. Reserved for LAN and USB ports 4-5 in VT8233 and VT8233C.

Power and Ground			
Signal Name	Pin #	I/O	Signal Description
VCC33	A1, 10, B1, D16, F7, G7, 11, 14, H5-6, K1, L5-6, M20, N15, P7, 10, 12, 16, R7, 12, 14, T18, W1, 20, Y1, 11, 20	P	I/O Power (3.3V ±5%).
VCC25	A20, B20, H15, J19, J20, K15	P	I/O Power (2.5V ±5%).
VCC	G8, G13, J6, J15, M6, M15, P8, P13	P	Core Power. 3.3V nominal ±5% (3.465V to 3.135V). This supply is turned on only when the mechanical switch on the power supply is turned on and the PWRON signal is conditioned high. <u>Note for motherboard designs to accommodate any of VIA's 8233 South Bridge family that this voltage is different from the VT8233 and VT8233C both of which require 2.5V VCC.</u>
GND	(See Pin List)	P	Ground. Connect to primary motherboard ground plane.
VSUS33	N5, P5, R5, R6	P	Suspend Power. Always available unless the mechanical switch of the power supply is turned off. If the "soft-off" state is not implemented, then this pin can be connected to VCC33. Signals powered by or referenced to this plane are: PWRGD, RSMRST#, PWRBTN#, SMBCK1/2, SMBDT1/2, GPO0, SUSA# / GPO1, SUSB# / GPO2, SUSC#, SUSST1# / GPO3, SUSCLK / GPO4, GPI1, GPI2 / EXTSMI#, GPI3 / RING#, GPI4 / LID, GPI5 / BATLOW#, GPI6 / PME#, GPI7 / SMBALRT#
VBAT	W4	P	RTC Battery. Battery input for internal RTC (RTCX1, RTCX2)
VLVREF	G16	P	V-Link Voltage Reference (0.9V). 0.34 x VCC25 to 0.38 x VCC25.
VCCVK	J16	P	V-Link Compensation Circuit Voltage (2.5V ±5%).
USBVCC	F14-F15	P	USB Differential Output Power. Power for USB differential outputs (USBP0+, P0-, P1+, P1-, P2+, P2-, P3+, P3-). Connect to VSUS33 through a ferrite bead.
USBGND	E14-E15	P	USB Differential Output Ground. Connect to GND through a ferrite bead.
PLLVCC	L16	P	PLL Power. Connect to VCC through a ferrite bead.
PLLGND	M16	P	PLL Ground. Connect to GND through a ferrite bead.

REGISTERS

Register Overview

The following tables summarize the configuration and I/O registers of the VT8233A. These tables also document the power-on default value (“Default”) and access type (“Acc”) for each register. Access type definitions used are RW (Read/Write), RO (Read/Only), “—” for reserved / used (essentially the same as RO), and RWC (or just WC) (Read / Write 1’s to Clear individual bits). Registers indicated as RW may have some read/only bits that always read back a fixed value (usually 0 if unused); registers designated as RWC or WC may have some read-only or read write bits (see individual register descriptions for details).

Detailed register descriptions are provided in the following section of this document. All offset and default values are shown in hexadecimal unless otherwise indicated

Table 4. Memory Mapped Registers

FEC00000	APIC Index	(8-bit)
FEC00010	APIC Data	(32-bit)
FEC00020	APIC IRQ Pin Assertion	(8-bit)
FEC00040	APIC EOI	(8-bit)

“APIC” = “Advanced Programmable Interrupt Controller”

Table 5. Function Summary

<u>Bus</u>	<u>Device</u>	<u>Func</u>	<u>Device ID</u>	<u>Function</u>
0	17 (11h)	0	3074h	Bus Control & Power Mgmt
0	17 (11h)	1	0571h	IDE Controller
0	17 (11h)	2	3038h	USB Controller Ports 0-1
0	17 (11h)	3	3038h	USB Controller Ports 2-3
0	17 (11h)	5	3059h	AC97 Audio Codec Controller
0	17 (11h)	6	3068h	MC97 Modem Codec Ctrlr

Table 6. System I/O Map

<u>Port</u>	<u>Function</u>	<u>Actual Port Decoding</u>
00-1F	Master DMA Controller	0000 0000 000x nnnn
20-3F	Master Interrupt Controller	0000 0000 001x xxxx
40-5F	Timer / Counter	0000 0000 010x xxnn
60-6F	Keyboard Controller	0000 0000 0110 xnnn
(60h)	KBC Data	0000 0000 0110 x0x0
(61h)	Misc Functions & Spkr Ctrl	0000 0000 0110 xxx1
(64h)	KBC Command / Status	0000 0000 0110 x1x0
70-77	RTC/CMOS/NMI-Disable	0000 0000 0111 0nnn
78-7F	-available for system use-	0000 0000 0111 1xxx
80	-reserved- (debug port)	0000 0000 1000 0000
81-8F	DMA Page Registers	0000 0000 1000 nnnn
90-91	-available for system use-	0000 0000 1001 000x
92	System Control	0000 0000 1001 0010
93-9F	-available for system use-	0000 0000 1001 nnnn
A0-BF	Slave Interrupt Controller	0000 0000 101x xxxx
C0-DF	Slave DMA Controller	0000 0000 110n nnnx
E0-FF	-available for system use-	0000 0000 111x xxxx
100-CF7	-available for system use*	
CF8-CFB	PCI Configuration Address	0000 1100 1111 10xx
CFC-CFF	PCI Configuration Data	0000 1100 1111 11xx
D00-FFFF	-available for system use-	

Table 7. Registers

Legacy I/O Registers

Port	Master DMA Controller Registers	Default	Acc
00	Channel 0 Base & Current Address		RW
01	Channel 0 Base & Current Count		RW
02	Channel 1 Base & Current Address		RW
03	Channel 1 Base & Current Count		RW
04	Channel 2 Base & Current Address		RW
05	Channel 2 Base & Current Count		RW
06	Channel 3 Base & Current Address		RW
07	Channel 3 Base & Current Count		RW
08	Status / Command		RW
09	Write Request		WO
0A	Write Single Mask		WO
0B	Write Mode		WO
0C	Clear Byte Pointer FF		WO
0D	Master Clear		WO
0E	Clear Mask		WO
0F	Read / Write Mask		RW

Port	Master Interrupt Controller Regs	Default	Acc
20	Master Interrupt Control	—	*
21	Master Interrupt Mask	—	*
20	Master Interrupt Control Shadow	—	RW
21	Master Interrupt Mask Shadow	—	RW

* RW if shadow registers are disabled

Port	Timer/Counter Registers	Default	Acc
40	Timer / Counter 0 Count		RW
41	Timer / Counter 1 Count		RW
42	Timer / Counter 2 Count		RW
43	Timer / Counter Control		WO

Port	Keyboard Controller Registers	Default	Acc
60	Keyboard Controller Data		RW
61	Misc Functions & Speaker Control		RW
64	Keyboard Ctrlr Command / Status		RW

Port	CMOS / RTC / NMI Registers	Default	Acc
70	CMOS Memory Address & NMI Disa		WO
71	CMOS Memory Data (128 bytes)		RW
74	CMOS Memory Address		RW
75	CMOS Memory Data (256 bytes)		RW

NMI Disable is port 70h (CMOS Memory Address) bit-7.
 RTC control occurs via specific CMOS data locations (0-Dh).
 Ports 72-73 may be used to access all 256 locations of CMOS.
 Ports 74-75 may be used to access CMOS if the internal RTC is disabled.

Legacy I/O Registers (continued)

Port	DMA Page Registers	Default	Acc
87	DMA Page – DMA Channel 0		RW
83	DMA Page – DMA Channel 1		RW
81	DMA Page – DMA Channel 2		RW
82	DMA Page – DMA Channel 3		RW
8F	DMA Page – DMA Channel 4		RW
8B	DMA Page – DMA Channel 5		RW
89	DMA Page – DMA Channel 6		RW
8A	DMA Page – DMA Channel 7		RW

Port	System Control Registers	Default	Acc
92	System Control		RW

Port	Slave Interrupt Controller Regs	Default	Acc
A0	Slave Interrupt Control	—	*
A1	Slave Interrupt Mask	—	*
A0	Slave Interrupt Control Shadow	—	RW
A1	Slave Interrupt Mask Shadow	—	RW

* RW accessible if shadow registers are disabled

Port	Slave DMA Controller Registers	Default	Acc
C0	Channel 0 Base & Current Address		RW
C2	Channel 0 Base & Current Count		RW
C4	Channel 1 Base & Current Address		RW
C6	Channel 1 Base & Current Count		RW
C8	Channel 2 Base & Current Address		RW
CA	Channel 2 Base & Current Count		RW
CC	Channel 3 Base & Current Address		RW
CE	Channel 3 Base & Current Count		RW
D0	Status / Command		RW
D2	Write Request		WO
D4	Write Single Mask		WO
D6	Write Mode		WO
D8	Clear Byte Pointer FF		WO
DA	Master Clear		WO
DC	Clear Mask		WO
DE	Read / Write Mask		RW

Keyboard / Mouse Wakeup Registers (I/O Space)

Port	KB / Mouse Wakeup Registers	Default	Acc
002E	Keyboard / Mouse Wakeup Index †	00	RW
002F	Keyboard / Mouse Wakeup Data †	00	RW

† Keyboard / Mouse Wakeup registers (index values E0-EF defined below) are accessible if Function 0 PCI Configuration register Rx51[1] = 1.

Keyboard / Mouse Wakeup Registers (Indexed via Port 2E/2F)

Offset	Reserved	Default	Acc
00-DF	-reserved-	—	RO

Offset	KB / Mouse Wakeup (Rx51[1]=1)	Default	Acc
E0	Keyboard / Mouse Wakeup Enable	08	RW
E1	Keyboard Wakeup Scan Code Set 0	F0	RW
E2	Keyboard Wakeup Scan Code Set 1	00	RW
E3	Keyboard Wakeup Scan Code Set 2	00	RW
E4	Keyboard Wakeup Scan Code Set 3	00	RW
E5	Keyboard Wakeup Scan Code Set 4	00	RW
E6	Keyboard Wakeup Scan Code Set 5	00	RW
E7	Keyboard Wakeup Scan Code Set 6	00	RW
E8	Keyboard Wakeup Scan Code Set 7	00	RW
E9	Mouse Wakeup Scan Code Set 1	09	RW
EA	Mouse Wakeup Scan Code Set 2	00	RW
EB	Mouse Wakeup Scan Code Mask	00	RW
EC-EF	-reserved-	—	RO

Game Port Registers (I/O Space)

Offset	Game Port (200-20F typical)	Default	Acc
0	-reserved-	00	—
1	Game Port Status		RO
1	Start One-Shot		WO
2-F	-reserved-	00	—

Memory Mapped Registers – IOAPIC

Address	APIC Index / Data	Default	Acc
FEC0000	APIC Register Index	00	RW
FEC0001-0F	-reserved-	00	—
FEC0010-13	APIC Register Data	0000 0000	RW
FEC0014-1F	-reserved-	00	—
FEC0020	APIC IRQ Pin Assertion	xx	WO
FEC0021-3F	-reserved-	00	—
FEC0040	APIC EOI	xx	WO
FEC0041-FF	-reserved-	00	—

Offset	APIC Registers	Default	Acc
0	APIC ID	0000 0000	RW
1	APIC Version	0017 8002	RO
2	APIC Arbitration	0000 0000	RO
3	Boot Configuration	0000 0000	RW
4-F	-reserved-	0000 0000	—
11-10	I/O Redirection– AIRQ0	xxx1xxxx xxxxxxxx	RW
13-12	I/O Redirection– AIRQ1	xxx1xxxx xxxxxxxx	RW
15-14	I/O Redirection– AIRQ2	xxx1xxxx xxxxxxxx	RW
17-16	I/O Redirection– AIRQ3	xxx1xxxx xxxxxxxx	RW
19-18	I/O Redirection– AIRQ4	xxx1xxxx xxxxxxxx	RW
1B-1A	I/O Redirection– AIRQ5	xxx1xxxx xxxxxxxx	RW
1D-1C	I/O Redirection– AIRQ6	xxx1xxxx xxxxxxxx	RW
1F-1E	I/O Redirection– AIRQ7	xxx1xxxx xxxxxxxx	RW
21-20	I/O Redirection– AIRQ8	xxx1xxxx xxxxxxxx	RW
23-20	I/O Redirection– AIRQ9	xxx1xxxx xxxxxxxx	RW
25-24	I/O Redirection– AIRQ10	xxx1xxxx xxxxxxxx	RW
27-26	I/O Redirection– AIRQ11	xxx1xxxx xxxxxxxx	RW
29-28	I/O Redirection– AIRQ12	xxx1xxxx xxxxxxxx	RW
2B-2A	I/O Redirection– AIRQ13	xxx1xxxx xxxxxxxx	RW
2D-2C	I/O Redirection– AIRQ14	xxx1xxxx xxxxxxxx	RW
2F-2E	I/O Redirection– AIRQ15	xxx1xxxx xxxxxxxx	RW
31-30	I/O Redirection– AIRQ16	xxx1xxxx xxxxxxxx	RW
33-32	I/O Redirection– AIRQ17	xxx1xxxx xxxxxxxx	RW
35-34	I/O Redirection– AIRQ18	xxx1xxxx xxxxxxxx	RW
37-36	I/O Redirection– AIRQ19	xxx1xxxx xxxxxxxx	RW
39-38	I/O Redirection– AIRQ20	xxx1xxxx xxxxxxxx	RW
3B-3A	I/O Redirection– AIRQ21	xxx1xxxx xxxxxxxx	RW
3D-3C	I/O Redirection– AIRQ22	xxx1xxxx xxxxxxxx	RW
3F-3E	I/O Redirection– AIRQ23	xxx1xxxx xxxxxxxx	RW
40-4F	-reserved-	0000 0000	—

Note: The “I/O Redirection” registers are 64-bit registers, so each uses two consecutive index locations, with the lower 32 bits at the even index and the upper 32 bits at the odd index.

Device 17 Function 0 Registers – Bus Control & Power Management
Configuration Space Bus Control & PM Header Registers

Offset	Configuration Space Header	Default	Acc
1-0	Vendor ID	1106	RO
3-2	Device ID (VT8233 “CE” = 3074)	3147	RO
5-4	Command	0087	RW
7-6	Status	0200	WC
8	Revision ID	nn	RO
9	Programming Interface	00	RO
A	Sub Class Code	01	RO
B	Base Class Code	06	RO
C	-reserved- (cache line size)	00	—
D	-reserved- (latency timer)	00	—
E	Header Type	80	RO
F	Built In Self Test (BIST)	00	RO
10-27	-reserved- (base address registers)	00	—
28-2B	-reserved- (unassigned)	00	—
2D-2C	Sub Vendor ID	00	RO
2F-2E	Sub Device ID	00	RO
30-33	-reserved- (expansion ROM base addr)	00	—
34-3B	-reserved- (unassigned)	00	—
3C	-reserved- (interrupt line)	00	—
3D	-reserved- (interrupt pin)	00	—
3E	-reserved- (min gnt)	00	—
3F	-reserved- (max lat)	00	—

Configuration Space PCI-to-ISA Bridge-Specific Registers

Offset	ISA Bus Control	Default	Acc
40	ISA Bus Control	00	RW
41	BIOS ROM Decode Control	00	RW
42	Line Buffer Control	00	RW
43	Delay Transaction Control	00	RW
44-47	-reserved-	00	—
48	Read Pass Write Control	00	RW
49	CCA Control	00	RW
4A-4B	-reserved-	00	—

Offset	Miscellaneous Control	Default	Acc
4C	IDE Interrupt Routing	00	RW
4D	VT8233 “CE”: External APIC IRQ Output Control	00	RW
4D	VT8233A: -reserved-	00	—
4E	Internal RTC Test Mode	00	RW
4F	PCI Bus & CPU Interface Control	00	RW

Offset	Function Control	Default	Acc
50	Function Control 1	09	RW
51	Function Control 2	0D	RW

Offset	Serial IRQ, LPC & PC/PCI Control	Default	Acc
52	Serial IRQ & LPC Control	00	RW
53	-reserved-	00	RW

Offset	Plug and Play Control	Default	Acc
54	PCI Interrupt Polarity	00	RW
55	PnP Routing for PCI INTA	00	RW
56	PnP Routing for PCI INTB-C	00	RW
57	PnP Routing for PCI INTD	00	RW

Offset	GPIO and Miscellaneous Control	Default	Acc
58	Miscellaneous Control 0	40	RW
59	Miscellaneous Control 1	00	RW
5A	DMA Bandwidth Control	00	RW
5B	-reserved-	00	—

Offset	Programmable Chip Select Control	Default	Acc
5D-5C	PCS0# I/O Port Address	0000	RW
5F-5E	PCS1# I/O Port Address	0000	RW
61-60	PCS2# I/O Port Address	0000	RW
63-62	PCS3# I/O Port Address	0000	RW
64	PCS[1-0]# I/O Port Address Mask	00	RW
65	PCS[3-2]# I/O Port Address Mask	00	RW
66	Programmable Chip Select Control	00	RW
67	Output Control	04	RW
68-6B	-reserved-	00	—

Offset	Miscellaneous	Default	Acc
6C	ISA Positive Decoding Control 1	00	RW
6D	ISA Positive Decoding Control 2	00	RW
6E	ISA Positive Decoding Control 3	00	RW
6F	ISA Positive Decoding Control 4	00	RW
71-70	Sub Vendor ID Backdoor	00	RW
73-72	Sub Device ID Backdoor	00	RW
70-78	-reserved-	00	—
79	PnP IRQ/DRQ Test (do not prog)	00	RW
7A	IDE / USB Test (do not program)	00	RW
7B	PLL Test (do not program)	00	RW
7C	I/O Pad Control	00	RW
7D-7F	-reserved-	00	—

Configuration Space Power Management Registers

Offset	Power Management	Default	Acc
80	General Configuration 0	00	RW
81	General Configuration 1	00	RW
82	ACPI Interrupt Select	00	RW
83	-reserved-	00	—
85-84	Primary Interrupt Channel	0000	RW
87-86	Secondary Interrupt Channel	0000	RW
8B-88	Power Mgmt I/O Base (256 Bytes)	0000 0001	RW
8C	Host Bus Power Mgmt Control	00	RW
8D	Throttle / Clock Stop Control	00	RW
8E-8F	-reserved-	00	—
93-90	GP Timer Control	0000 0000	RW
94	Power Well Control	00	RW
95	Miscellaneous Control	00	RW
96	Power On / Reset Control	00	RW
97	-reserved-	00	—
98	GP2 / GP3 Timer Control	00	RW
99	GP2 Timer	00	RW
9A	GP3 Timer	00	RW
9B-A0	-reserved-	00	—
A1	Write value for Offset 9 (Prog Intfc)	00	WO
A2	Write value for Offset A (Sub Class)	00	WO
A3	Write value for Offset B (Base Class)	00	WO
A4-BF	-reserved-	00	—
C3-C0	Power Manangement Capability	0002 0001	RO
C7-C4	Power Mgmt Capability CSR	0000 0000	RW
C8-CF	-reserved-	00	—

Configuration Space SMBus Registers

Offset	System Management Bus	Default	Acc
D1-D0	SMBus I/O Base (16 Bytes)	0001	RW
D2	SMBus Host Configuration	00	RW
D3	SMBus Host Slave Command	00	RW
D4	SMBus Slave Address Shadow Port 1	00	RW
D5	SMBus Slave Address Shadow Port 2	00	RW
D6	SMBus Revision ID	nn	RO
D7-DF	-reserved-	00	—

Configuration Space General Purpose I/O Registers

Offset	General Purpose I/O	Default	Acc
E0	GPI Inversion Control	00	RW
E1	GPI SCI / SMI Select	00	RW
E2-E3	-reserved-	00	—
E4	GPO Pin Select	00	RW
E5	GPIO I/O Select 1	00	RW
E6	GPIO I/O Select 2	00	RW
E7	GPO Output Type	00	RW
E8-FF	-reserved-	00	—

I/O Space Power Management Registers

Offset	Basic Control / Status Registers	Default	Acc
1-0	Power Management Status	0000	WC
3-2	Power Management Enable	0000	RW
5-4	Power Management Control	0000	RW
6-7	-reserved-	00	—
B-8	Power Management Timer	0000 0000	RW
C-F	-reserved-	00	—

Offset	Processor Registers	Default	Acc
13-10	Processor and PCI Bus Control	0000 0000	RW
14	Processor LVL2	00	RO
15	Processor LVL3	00	RO
16-1F	-reserved-	00	—

Offset	General Purpose Registers	Default	Acc
21-20	General Purpose Status	0000	WC
23-22	General Purpose SCI Enable	0000	RW
25-24	General Purpose SMI Enable	0000	RW
26-27	-reserved-	00	—

Offset	Generic Registers	Default	Acc
29-28	Global Status	0000	WC
2B-2A	Global Enable	0000	RW
2D-2C	Global Control	0010	RW
2E	-reserved-	00	—
2F	SMI Command	00	RW
33-30	Primary Activity Detect Status	0000 0000	WC
37-34	Primary Activity Detect Enable	0000 0000	RW
3B-38	GP Timer Reload Enable	0000 0000	RW
3C-3F	-reserved-	00	—

Offset	General Purpose I/O Registers	Default	Acc
40	Extended I/O Trap Status	00	WC
41	-reserved-	00	—
42	Extended I/O Trap Enable	00	RW
43-44	-reserved-	00	—
45	SMI / IRQ / Resume Status	00	RO
46-47	-reserved-	00	—
4B-48	GPI Port Input Value	input	RO
4F-4C	GPO Port Output Value	FFFFFFF	RW
50	GPI Pin Change Status	00	RW
51	-reserved-	00	—
52	GPI Pin Change SCI/SMI Select	00	RW
53-57	-reserved-	00	—
59-58	I/O Trap PCI I/O Address	0000	RO
5A	I/O Trap PCI Command / Byte Ena	00	RO
5B-FF	-reserved-	00	—

I/O Space System Management Bus Registers

Offset	System Management Bus	Default	Acc
0	SMBus Host Status	00	WC
1	SMBus Slave Status	00	RW
2	SMBus Host Control	00	RW
3	SMBus Host Command	00	RW
4	SMBus Host Address	00	RW
5	SMBus Host Data 0	00	RW
6	SMBus Host Data 1	00	RW
7	SMBus Block Data	00	RW
8	SMBus Slave Control	00	RW
9	SMBus Shadow Command	00	RO
A-B	SMBus Slave Event	0000	RW
C-D	SMBus Slave Data	0000	RO
E-F	-reserved-	00	—

Device 18 Function 1 Registers – IDE Controller
Configuration Space IDE Header Registers

Offset	Configuration Space Header	Default	Acc
1-0	Vendor ID	1106	RO
3-2	Device ID	0571	RO
5-4	Command	0080	RO
7-6	Status	0290	RW
8	Revision ID	nn	RO
9	Programming Interface	85	RW
A	Sub Class Code	01	RO
B	Base Class Code	01	RO
C-F	-reserved-	00	—
13-10	Base Address – Pri Data / Command	000001F1	RW
17-14	Base Address – Pri Control / Status	000003F5	RW
1B-18	Base Address – Sec Data / Command	00000171	RW
1F-1C	Base Address – Sec Control / Status	00000375	RW
23-20	Base Address – Bus Master Control	0000CC01	RW
24-2B	-reserved- (unassigned)	00	—
2D-2C	Sub Vendor ID	0000	RO
2F-2E	Sub Device ID	0000	RO
30-33	-reserved- (expan ROM base addr)	00	—
34	Capability Pointer	C0	RO
35-3B	-reserved- (unassigned)	00	—
3C	Interrupt Line	0E	RO
3D	Interrupt Pin	00	RO
3E	Minimum Grant	00	RO
3F	Maximum Latency	00	RO

Configuration Space IDE-Specific Registers

Offset	Configuration Space IDE Registers	Default	Acc
40	IDE Chip Enable	08	RW
41	IDE Configuration I	02	RW
42	IDE Configuration II	C0	RW
43	IDE FIFO Configuration	3A	RW
44	IDE Miscellaneous Control 1	08	RW
45	IDE Miscellaneous Control 2	03	RW
46	IDE Miscellaneous Control 3	C0	RW
4B-48	IDE Drive Timing Control	A8A8A8A8	RW
4C	IDE Address Setup Time	FF	RW
4D	-reserved- (do not program)	00	RW
4E	Sec Non-1F0 Port Access Timing	B6	RW
4F	Pri Non-1F0 Port Access Timing	B6	RW

Configuration Space IDE-Specific Registers (continued)

Offset	Configuration Space IDE Registers	Default	Acc
53-50	UltraDMA Extended Timing Control	07070707	RW
54	UltraDMA FIFO Control	04	RW
55-5F	-reserved-	00	—
61-60	IDE Primary Sector Size	0200	RW
62-67	-reserved-	00	—
69-68	IDE Secondary Sector Size	0200	RW
69-6F	-reserved-	00	—
70	IDE Primary Status	00	RW
71	IDE Primary Interrupt Control	01	RW
72-77	-reserved-	00	—
78	IDE Secondary Status	00	RW
79	IDE Secondary Interrupt Control	01	RW
7A-7F	-reserved-	00	—
83-80	IDE Primary S/G Descriptor Address	0000 0000	RW
84-87	-reserved-	00	—
8B-88	IDE Secondary S/G Descriptor Addr	0000 0000	RW
8C-BF	-reserved-	00	—
C3-C0	Power Management Capabilities	0002 0001	RO
C7-C4	Power State	0000 0000	RW
C8-CF	-reserved-	00	—

Offset	IDE Back Door Registers	Default	Acc
D0	Back Door – Revision ID	06	RW
D1	-reserved-	00	—
D3-D2	Back Door – Device ID	0571	RW
D5-D4	Back Door – Sub Vendor ID	0000	RW
D7-D6	Back Door – Sub Device ID	0000	RW
D8-FF	-reserved-	00	—

I/O Registers – IDE Controller (SFF 8038 v1.0 Compliant)

Offset	IDE I/O Registers	Default	Acc
0	Primary Channel Command	00	RW
1	-reserved-	00	—
2	Primary Channel Status	00	WC
3	-reserved-	00	—
4-7	Primary Channel PRD Table Addr	00	RW
8	Secondary Channel Command	00	RW
9	-reserved-	00	—
A	Secondary Channel Status	00	WC
B	-reserved-	00	—
C-F	Secondary Channel PRD Table Addr	00	RW

Device 17 Function 2 Registers – USB Ports 0-1
Configuration Space USB Header Registers

Offset	Configuration Space Header	Default	Acc
1-0	Vendor ID	1106	RO
3-2	Device ID	3038	RO
5-4	Command	0000	RW
7-6	Status	0200	WC
8	Revision ID	nn	RO
9	Programming Interface	00	RO
A	Sub Class Code	03	RO
B	Base Class Code	0C	RO
C-1F	-reserved-	00	—
23-20	USB I/O Register Base Address	00000301	RW
24-2B	-reserved-	00	—
2D-2C	Sub Vendor ID	00	RO
2F-2E	Sub Device ID	00	RO
30-3B	-reserved-	00	—
3C	Interrupt Line	00	RW
3D	Interrupt Pin	04	RO
3E-3F	-reserved-	00	—

Configuration Space USB-Specific Registers

Offset	USB Control	Default	Acc
40	USB Miscellaneous Control 1	00	RW
41	USB Miscellaneous Control 2	10	RW
42-43	-reserved-	00	—
44-45	-reserved- (test, do not program)	00	RW
46-47	-reserved- (test)	00	RO
48	USB Miscellaneous Control 3	00	RW
49	MIA Analog Control	00	RW
4A-5F	-reserved-	00	—
60	USB Serial Bus Release Number	10	RO
61-7F	-reserved-	00	—
83-80	PM Capability	0002 0001	RO
84	PM Capability Status	00	RW
85-BF	-reserved-	00	—
C1-C0	USB Legacy Support	2000	RW
C2-FF	-reserved-	00	—

I/O Registers – USB Controller

Offset	USB I/O Registers	Default	Acc
1-0	USB Command	0000	RW
3-2	USB Status	0000	WC
5-4	USB Interrupt Enable	0000	RW
7-6	Frame Number	0000	RW
B-8	Frame List Base Address	00000000	RW
C	Start Of Frame Modify	40	RW
11-10	Port 0 Status / Control	0080	WC
13-12	Port 1 Status / Control	0080	WC
14-1F	-reserved-	00	—

Device 17 Function 3 Registers – USB Ports 2-3
Configuration Space USB Header Registers

Offset	Configuration Space Header	Default	Acc
1-0	Vendor ID	1106	RO
3-2	Device ID	3038	RO
5-4	Command	0000	RW
7-6	Status	0200	WC
8	Revision ID	nn	RO
9	Programming Interface	00	RO
A	Sub Class Code	03	RO
B	Base Class Code	0C	RO
C-1F	-reserved-	00	—
23-20	USB I/O Register Base Address	00000301	RW
24-2B	-reserved-	00	—
2D-2C	Sub Vendor ID	00	RO
2F-2E	Sub Device ID	00	RO
30-3B	-reserved-	00	—
3C	Interrupt Line	00	RW
3D	Interrupt Pin	04	RO
3E-3F	-reserved-	00	—

Configuration Space USB-Specific Registers

Offset	USB Control	Default	Acc
40	USB Miscellaneous Control 1	00	RW
41	USB Miscellaneous Control 2	10	RW
42-43	-reserved-	00	—
44-45	-reserved- (test, do not program)	00	RW
46-47	-reserved- (test)	00	RO
48	USB Miscellaneous Control 3	00	RW
49	MIA Analog Control	00	RW
4A-5F	-reserved-	00	—
60	USB Serial Bus Release Number	10	RO
61-7F	-reserved-	00	—
83-80	PM Capability	0002 0001	RO
84	PM Capability Status	00	RW
85-BF	-reserved-	00	—
C1-C0	USB Legacy Support	2000	RW
C2-FF	-reserved-	00	—

I/O Registers - USB Controller

Offset	USB I/O Registers	Default	Acc
1-0	USB Command	0000	RW
3-2	USB Status	0000	WC
5-4	USB Interrupt Enable	0000	RW
7-6	Frame Number	0000	RW
B-8	Frame List Base Address	00000000	RW
C	Start Of Frame Modify	40	RW
11-10	Port 2 Status / Control	0080	WC
13-12	Port 3 Status / Control	0080	WC
14-1F	-reserved-	00	—

Device 17 Function 5 & 6 Registers – AC/MC97 Codecs
Function 5 Configuration Space AC97 Header Registers

Offset	Configuration Space Header	Default	Acc
1-0	Vendor ID	1106	RO
3-2	Device ID	3059	RO
5-4	Command	0000	RW
7-6	Status	0210	RO
8	Revision ID	40	RO
9	Programming Interface	00	RO
A	Sub Class Code	01	RO
B	Base Class Code	04	RO
C-F	-reserved-	00	—
13-10	Base Address 0 - SGD Control/Status	0000 0001	RW
17-14	Base Address 1 (reserved)	0000 0000	—
1B-18	Base Address 2 (reserved)	0000 0000	—
1F-1C	Base Address 3 (reserved)	0000 0000	—
23-20	Base Address 4 (reserved)	0000 0000	—
27-24	Base Address 5 (reserved)	0000 0000	—
28-29	-reserved-	00	—
2D-2C	Sub Vendor ID	00	RO
2F-2E	Sub Device ID	00	RO
33-30	Expansion ROM (reserved)	0000 0000	—
34	Capture Pointer	C0	RW
35-3B	-reserved-	00	—
3C	Interrupt Line	00	RW
3D	Interrupt Pin	03	RO
3E	Minimum Grant	00	RO
3F	Maximum Latency	00	RO

Configuration Space Audio Codec-Specific Registers

Offset	Audio Codec Link Control	Default	Acc
40	AC-Link Interface Status	00	RO
41	AC-Link Interface Control	00	RW
42	Function Enable	00	RW
43	-reserved-	00	—
44	MC97 Interface Control	00	RO
45-47	-reserved-	00	—
48	Value Change Rate Control	00	RW
49	S/PDIF Control	00	RW
4A-BF	-reserved-	00	—
C3-C0	Power Management Capability	0002 0001	RO
C7-C4	Power State	0000 0000	RW
C8-FF	-reserved-	00	—

Function 6 Configuration Space MC97 Header Registers

Offset	Configuration Space Header	Default	Acc
1-0	Vendor ID	1106	RO
3-2	Device ID	3068	RO
5-4	Command	0000	RW
7-6	Status	0200	RO
8	Revision ID	78	RO
9	Programming Interface	00	RO
A	Sub Class Code	80	RO
B	Base Class Code	07	RO
C-F	-reserved-	00	—
13-10	Base Address 0 - SGD Control/Status	0000 0001	RW
17-14	Base Address 1 (reserved)	0000 0000	—
1B-18	Base Address 2 (reserved)	0000 0000	—
1F-1C	Base Address 3 (reserved)	0000 0000	—
23-20	Base Address 4 (reserved)	0000 0000	—
27-24	Base Address 5 (reserved)	0000 0000	—
28-29	-reserved-	00	—
2D-2C	Sub Vendor ID	00	RO
2F-2E	Sub Device ID	00	RO
33-30	Expansion ROM (reserved)	0000 0000	—
34	Capture Pointer	D0	RW
35-3B	-reserved-	00	—
3C	Interrupt Line	00	RW
3D	Interrupt Pin	03	RO
3E	Minimum Grant	00	RO
3F	Maximum Latency	00	RO

Configuration Space Modem Codec-Specific Registers

Offset	Modem Codec Link Control	Default	Acc
40	AC-Link Interface Status	00	RO
41	AC-Link Interface Control	00	RW
42	Function Enable	00	RO
43	-reserved-	00	—
44	MC97 Interface Control	00	RW
45-47	-reserved-	00	—
48	Value Change Rate Control	00	RO
49	S/PDIF Control	00	RO
4A-CF	-reserved-	00	—
D3-D0	Power Management Capability	0002 0001	RO
D7-D4	Power State	0000 0000	RW
D8-FF	-reserved-	00	—

Function 5 I/O Base 0 Registers – AC97 Audio S/G DMA

Offset	AC97 SGD I/O Registers	Default	Acc
00-2F	-reserved- (8233/8233C Channels0-2)	00	—
30	SGD Channel 3 Status	00	WC
31	SGD Channel 3 Control	00	RW
32	SGD Channel 3 Left Volume	3F	RW
33	SGD Channel 3 Right Volume	3F	RW
37-34	SGD Channel 3 Table Pointer Base SGD Channel 3 Current Address	0000 0000	WR RD
3B-38	Stop Index / Data Type / Sample Rate	FF0F FFFF	RW
3F-3C	SGD Channel 3 Current Count	0000 0000	RO
40	SGD 3D Channel Status	00	WC
41	SGD 3D Channel Control	00	RW
42	SGD 3D Channel Format	00	RW
43	SGD 3D Channel Scratch	00	RW
47-44	SGD 3D Channel Table Pointer Base SGD 3D Channel Current Address	0000 0000	WR RD
4B-48	SGD 3D Channel Stop Index	FF00 0000	RW
4F-4C	SGD 3D Channel Current Count	0000 0000	RO
50-5F	-reserved-	00	—
60	SGD Write Channel 0 Status	00	WC
61	SGD Write Channel 0 Control	00	RW
62	SGD Write Channel 0 Format	00	RW
63	SGD Write Channel 0 Select	00	RW
67-64	SGD Write Channel 0 Table Ptr Base SGD Write Channel 0 Current Addr	0000 0000	WR RD
6B-68	SGD Write Channel 0 Stop Index	FF00 0000	RW
6F-6C	SGD Write Channel 0 Current Count	0000 0000	RO
70-7F	-reserved- (8233/8233C Write Chan1)	00	—

Offset	AC97 / Audio Codec I/O Registers	Default	Acc
83-80	AC97 Controller Command / Status	0000 0000	RW
87-84	SGD Global IRQ Shadow	0000 0000	RO
8B-88	Modem Codec GPI Intr Status / GPIO	0000 0000	RO
8F-8C	Modem Codec GPI Interrupt Enable	0000 0000	RO
90-9F	Shadow PCI Config Registers 40-4F	n/a	RO
A0-FF	-reserved-	00	—

Function 6 I/O Base 0 Registers – MC97 Modem S/G DMA

Offset	MC97 SGD I/O Registers	Default	Acc
0-7	-reserved-	00	—
8-F	-reserved-	00	—
10-17	-reserved-	00	—
18-1F	-reserved-	00	—
20-27	-reserved-	00	—
28-2F	-reserved-	00	—
30-37	-reserved-	00	—
38-3F	-reserved-	00	—
40	SGD Read Channel Status	00	WC
41	SGD Read Channel Control	00	RW
42	SGD Read Channel Type	00	RW
43	-reserved-	00	—
47-44	SGD Read Chan Table Pointer Base SGD Read Channel Current Address	0000 0000	WR RD
4B-48	-reserved- (Test)	0000 0000	RO
4F-4C	SGD Read Channel Current Count	0000 0000	RO
50	SGD Write Channel Status	00	WC
51	SGD Write Channel Control	00	RW
52	SGD Write Channel Type	00	RW
53	-reserved-	00	—
57-54	SGD Write Channel Table Ptr Base SGD Write Channel Current Address	0000 0000	WR RD
5B-58	Reserved (Test)	0000 0000	RO
5F-5C	SGD Write Channel Current Count	0000 0000	RO
60-7F	-reserved-	00	—

Offset	AC97 / Modem Codec I/O Registers	Default	Acc
83-80	AC97 Controller Command / Status	0000 0000	RW
87-84	SGD Global IRQ Shadow	0000 0000	RO
8B-88	Modem Codec GPI Intr Status / GPIO	0000 0000	WC
8F-8C	Modem Codec GPI Interrupt Enable	0000 0000	RW
90-9F	Shadow PCI Config Registers 40-4F	n/a	RO
A0-FF	-reserved-	00	—

Register Descriptions

Legacy I/O Ports

This group of registers includes the DMA Controllers, Interrupt Controllers, and Timer/Counters as well as a number of miscellaneous ports originally implemented using discrete logic on original PC/AT motherboards. All of the registers listed are integrated on-chip. These registers are implemented in a precise manner for backwards compatibility with previous generations of PC hardware. These registers are listed for information purposes only. Detailed descriptions of the actions and programming of these registers are included in numerous industry publications (duplication of that information here is beyond the scope of this document). All of these registers reside in I/O space.

Port 61 - Misc Functions & Speaker Control..... RW

- 7-6 Reserved**always reads 0
- 5 Timer/Counter 2 Output**RO
This bit reflects the output of Timer/Counter 2 without any synchronization.
- 4 Refresh Detected**RO
This bit toggles on every rising edge of the ISA bus REFRESH# signal.
- 3-2 Reserved**RW, default=0
- 1 Speaker Enable**.....RW
 - 0 Disable..... default
 - 1 Enable Timer/Ctr 2 output to drive SPKR pin
- 0 Timer/Counter 2 Enable**.....RW
 - 0 Disable..... default
 - 1 Enable Timer/Counter 2

Port 92h - System Control RW

- 7-6 Hard Disk Activity LED Status**
 - 0 Off default
 - 1-3 On
- 5-4 Reserved**always reads 0
- 3 Power-On Password Bytes Inaccessible** .. default=0
- 2 Reserved**always reads 0
- 1 A20 Address Line Enable**
 - 0 A20 disabled / forced 0 (real mode) default
 - 1 A20 address line enabled
- 0 High Speed Reset**
 - 0 Normal
 - 1 Briefly pulse system reset to switch from protected mode to real mode

Keyboard Controller I/O Registers

The keyboard controller handles the keyboard and mouse interfaces. Two ports are used: port 60 and port 64. Reads from port 64 return a status byte. Writes to port 64h are command codes (see command code list following the register descriptions). Input and output data is transferred via port 60.

A “Control” register is also available. It is accessible by writing commands 20h / 60h to the command port (port 64h); The control byte is written by first sending 60h to the command port, then sending the control byte value. The control register may be read by sending a command of 20h to port 64h, waiting for “Output Buffer Full” status = 1, then reading the control byte value from port 60h.

Traditional (non-integrated) keyboard controllers have an “Input Port” and an “Output Port” that control pins dedicated to specific functions. In the integrated version, connections are hard wired as listed below. Outputs are “open-collector” so to allow input on one of these pins, the output value for that pin would be set high (non-driving) and the desired input value read on the input port. These ports are defined as follows:

Bit Input Port

- 0 Keyboard Data In
- 1 Mouse Data In

Bit Output Port

- 0 System Reset (1 = Execute Reset)
- 1 Gaste A20 (1 = A20 Enabled)
- 2 Mouse Data Out
- 3 Mouse Clock Out
- 6 Keyboard Clock Out
- 7 Keyboard Data Out

Bit Test Port

- 0 Keyboard Clock In
- 1 Mouse Clock In

Hardwired Internal Connections

Keyboard Data Out (Open Collector) <=> Keyboard Data In

Keyboard Clock Out (Open Collector) <=> Keyboard Clk In

Mouse Data Out (Open Collector) <=> Mouse Data In

Mouse Clock Out (Open Collector) <=> Mouse Clock In

Keyboard OBF Interrupt => IRQ1

Mouse OBF Interrupt => IRQ12

Input / Output / Test Port Command Codes

C0h transfers input port data to the output buffer.

D0h copies output port values to the output buffer.

E0h transfers test input port data to the output buffer.

The above definitions are provided for reference only as actual keyboard and mouse control is no longer performed bit-by bit using the above ports but controlled directly by keyboard / mouse controller internal logic. Data is sent and received using the command codes listed on the following page.

Port 60 - Keyboard Controller Input Buffer..... WO

Only write to port 60h if port 64h bit-1 = 0 (1=full).

Port 60 - Keyboard Controller Output Buffer..... RO

Only read from port 60h if port 64h bit-0 = 1 (0=empty).

Port 64 - Keyboard / Mouse Status..... RO

- 7 Parity Error**
 - 0 No parity error (odd parity received)..... default
 - 1 Even parity occurred on last byte received from keyboard / mouse
- 6 General Receive / Transmit Timeout**
 - 0 No error default
 - 1 Error
- 5 Mouse Output Buffer Full**
 - 0 Mouse output buffer empty default
 - 1 Mouse output buffer holds mouse data
- 4 Keylock Status**
 - 0 Locked
 - 1 Free
- 3 Command / Data**
 - 0 Last write was data write..... default
 - 1 Last write was command write
- 2 System Flag**
 - 0 Power-On Default..... default
 - 1 Self Test Successful
- 1 Input Buffer Full**
 - 0 Input Buffer Empty default
 - 1 Input Buffer Full
- 0 Keyboard Output Buffer Full**
 - 0 Keyboard Output Buffer Empty default
 - 1 Keyboard Output Buffer Full

KBC Control Register.....(R/W via Commands 20h/60h)

- 7 Reserved** always reads 0
- 6 PC Compatibility**
 - 0 Disable scan conversion
 - 1 Convert scan codes to PC format; convert 2-byte break sequences to 1-byte PC-compatible break codes..... default
- 5 Mouse Interface**
 - 0 Enable..... default
 - 1 Disable
- 4 Keyboard Interface**
 - 0 Enable..... default
 - 1 Disable
- 3 Reserved** always reads 0
- 2 System Flag** default=0
This bit may be read back as status register bit-2
- 1 Mouse Interrupts**
 - 0 Disable..... default
 - 1 Enable - Generate interrupt on IRQ12 when mouse data comes into output buffer
- 0 Keyboard Interrupts**
 - 0 Disable..... default
 - 1 Enable - Generate interrupt on IRQ1 when output buffer has been written.

Port 64 - Keyboard / Mouse CommandWO

This port is used to send commands to the keyboard / mouse controller. The command codes recognized by the VT8233A are listed in the table below.

Table 8. Keyboard Controller Command Codes

Code	Keyboard Command Code Description
20h	Read Control Byte (next byte is Control Byte)
21-3Fh	Read SRAM Data (next byte is Data Byte)
60h	Write Control Byte (next byte is Control Byte)
61-7Fh	Write SRAM Data (next byte is Data Byte)
A1h	Output Keyboard Controller Version #
A4h	Test if Password is installed (always returns F1h to indicate not installed)
A7h	Disable Mouse Interface
A8h	Enable Mouse Interface
A9h	Mouse Interface Test (puts test results in port 60h) (value: 0=OK, 1=clk stuck low, 2=clk stuck high, 3=data stuck lo, 4=data stuck hi, FF=general error)
AAh	KBC self test (returns 55h if OK, FCh if not)
ABh	Keyboard Interface Test (see A9h Mouse Test)
ADh	Disable Keyboard Interface
A Eh	Enable Keyboard Interface
AFh	Return Version #
C0h	Read Input Port (read input data to output buffer)
C1h	Poll Input Port (read Mouse Data In continuously to status bit 5)
C8h	Unblock Mouse Output (use before D1 to change active mode)
C9h	Reblock Mouse Output (protection mechanism for D1)
CAh	Read Mode (output KBC mode info to port 60 output buffer: bit-0=0 if ISA, 1 if PS/2)
D0h	Read Output Port (copy output port values to port 60)
D1h	Write Output Port (data byte following is written to keyboard output port as if it came from keyboard)
D2h	Write Keyboard Output Buffer & clear status bit-5 (write following byte to keyboard)
D3h	Write Mouse Output Buffer & set status bit-5 (write following byte to mouse; put value in mouse input buffer so it appears to have come from the mouse)
D4h	Write Mouse (write following byte to mouse)
E0h	Read Keyboard Clock In and Mouse Clock In (return in bits 0-1 respectively of response byte)
Exh	Set Mouse Clock Out per command bit 3 Set Mouse Data Out per command bit 2 Set Gate A20 per command bit 1
Fxh	Pulse Mouse Clock Out low for 6usec per cmd bit 3 Pulse Mouse Data Out low for 6usec per cmd bit 2 Pulse Gate A20 low for 6usec per command bit 1 Pulse System Reset low for 6usec per cmd bit 0

All other codes not listed are undefined.

DMA Controller I/O Registers

Ports 00-0F - Master DMA Controller

Channels 0-3 of the Master DMA Controller control System DMA Channels 0-3. There are 16 Master DMA Controller registers:

<u>I/O Address Bits 15-0</u>	<u>Register Name</u>	
0000 0000 000x 0000	Ch 0 Base / Current Address	RW
0000 0000 000x 0001	Ch 0 Base / Current Count	RW
0000 0000 000x 0010	Ch 1 Base / Current Address	RW
0000 0000 000x 0011	Ch 1 Base / Current Count	RW
0000 0000 000x 0100	Ch 2 Base / Current Address	RW
0000 0000 000x 0101	Ch 2 Base / Current Count	RW
0000 0000 000x 0110	Ch 3 Base / Current Address	RW
0000 0000 000x 0111	Ch 3 Base / Current Count	RW
0000 0000 000x 1000	Status / Command	RW
0000 0000 000x 1001	Write Request	WO
0000 0000 000x 1010	Write Single Mask	WO
0000 0000 000x 1011	Write Mode	WO
0000 0000 000x 1100	Clear Byte Pointer F/F	WO
0000 0000 000x 1101	Master Clear	WO
0000 0000 000x 1110	Clear Mask	WO
0000 0000 000x 1111	R/W All Mask Bits	RW

Ports C0-DF - Slave DMA Controller

Channels 0-3 of the Slave DMA Controller control System DMA Channels 4-7. There are 16 Slave DMA Controller registers:

<u>I/O Address Bits 15-0</u>	<u>Register Name</u>	
0000 0000 1100 000x	Ch 4 Base / Current Address	RW
0000 0000 1100 001x	Ch 4 Base / Current Count	RW
0000 0000 1100 010x	Ch 5 Base / Current Address	RW
0000 0000 1100 011x	Ch 5 Base / Current Count	RW
0000 0000 1100 100x	Ch 6 Base / Current Address	RW
0000 0000 1100 101x	Ch 6 Base / Current Count	RW
0000 0000 1100 110x	Ch 7 Base / Current Address	RW
0000 0000 1100 111x	Ch 7 Base / Current Count	RW
0000 0000 1101 000x	Status / Command	RW
0000 0000 1101 001x	Write Request	WO
0000 0000 1101 010x	Write Single Mask	WO
0000 0000 1101 011x	Write Mode	WO
0000 0000 1101 100x	Clear Byte Pointer F/F	WO
0000 0000 1101 101x	Master Clear	WO
0000 0000 1101 110x	Clear Mask	WO
0000 0000 1101 111x	Read/Write All Mask Bits	WO

Note that not all bits of the address are decoded.

The Master and Slave DMA Controllers are compatible with the Intel 8237 DMA Controller chip. Detailed description of 8237 DMA controller operation can be obtained from the Intel Peripheral Components Data Book and numerous other industry publications.

Ports 80-8F - DMA Page Registers

There are eight DMA Page Registers, one for each DMA channel. These registers provide bits 16-23 of the 24-bit address for each DMA channel (bits 0-15 are stored in registers in the Master and Slave DMA Controllers). They are located at the following I/O Port addresses:

<u>I/O Address Bits 15-0</u>	<u>Register Name</u>	
0000 0000 1000 0111	Channel 0 DMA Page (M-0).....	RW
0000 0000 1000 0011	Channel 1 DMA Page (M-1).....	RW
0000 0000 1000 0001	Channel 2 DMA Page (M-2).....	RW
0000 0000 1000 0010	Channel 3 DMA Page (M-3).....	RW
0000 0000 1000 1111	Channel 4 DMA Page (S-0)	RW
0000 0000 1000 1011	Channel 5 DMA Page (S-1)	RW
0000 0000 1000 1001	Channel 6 DMA Page (S-2)	RW
0000 0000 1000 1010	Channel 7 DMA Page (S-3)	RW

DMA Controller Shadow Registers

The DMA Controller shadow registers are enabled by setting function 0 Rx77 bit 0. If the shadow registers are enabled, they are read back at the indicated I/O port instead of the standard DMA controller registers (writes are unchanged).

<u>Port 0 –Channel 0 Base Address</u>	<u>RO</u>
<u>Port 1 –Channel 0 Byte Count.....</u>	<u>RO</u>
<u>Port 2 –Channel 1 Base Address</u>	<u>RO</u>
<u>Port 3 –Channel 1 Byte Count.....</u>	<u>RO</u>
<u>Port 4 –Channel 2 Base Address</u>	<u>RO</u>
<u>Port 5 –Channel 2 Byte Count.....</u>	<u>RO</u>
<u>Port 6 –Channel 3 Base Address</u>	<u>RO</u>
<u>Port 7 –Channel 3 Byte Count.....</u>	<u>RO</u>
<u>Port 8 –1st Read Channel 0-3 Command Register</u>	<u>RO</u>
<u>Port 8 –2nd Read Channel 0-3 Request Register</u>	<u>RO</u>
<u>Port 8 –3rd Read Channel 0 Mode Register</u>	<u>RO</u>
<u>Port 8 –4th Read Channel 1 Mode Register</u>	<u>RO</u>
<u>Port 8 –5th Read Channel 2 Mode Register</u>	<u>RO</u>
<u>Port 8 –6th Read Channel 3 Mode Register</u>	<u>RO</u>
<u>Port F –Channel 0-3 Read All Mask.....</u>	<u>RO</u>
<u>Port C4 –Channel 5 Base Address</u>	<u>RO</u>
<u>Port C6 –Channel 5 Byte Count.....</u>	<u>RO</u>
<u>Port C8 –Channel 6 Base Address</u>	<u>RO</u>
<u>Port CA –Channel 6 Byte Count.....</u>	<u>RO</u>
<u>Port CC –Channel 7 Base Address</u>	<u>RO</u>
<u>Port CE –Channel 7 Byte Count</u>	<u>RO</u>
<u>Port D0 –1st Read Channel 4-7 Command Register</u>	<u>RO</u>
<u>Port D0 –2nd Read Channel 4-7 Request Register</u>	<u>RO</u>
<u>Port D0 –3rd Read Channel 4 Mode Register</u>	<u>RO</u>
<u>Port D0 –4th Read Channel 5 Mode Register</u>	<u>RO</u>
<u>Port D0 –5th Read Channel 6 Mode Register</u>	<u>RO</u>
<u>Port D0 –6th Read Channel 7 Mode Register</u>	<u>RO</u>
<u>Port DE –Channel 4-7 Read All Mask.....</u>	<u>RO</u>

Interrupt Controller I/O Registers

Ports 20-21 - Master Interrupt Controller

The Master Interrupt Controller controls system interrupt channels 0-7. Two registers control the Master Interrupt Controller. They are:

<u>I/O Address Bits 15-0</u>	<u>Register Name</u>	
0000 0000 001x xxx0	Master Interrupt Control	RW
0000 0000 001x xxx1	Master Interrupt Mask	RW

Note that not all bits of the address are decoded.

The Master Interrupt Controller is compatible with the Intel 8259 Interrupt Controller chip. Detailed descriptions of 8259 Interrupt Controller operation can be obtained from the Intel Peripheral Components Data Book and numerous other industry publications.

Ports A0-A1 - Slave Interrupt Controller

The Slave Interrupt Controller controls system interrupt channels 8-15. The slave system interrupt controller also occupies two register locations:

<u>I/O Address Bits 15-0</u>	<u>Register Name</u>	
0000 0000 101x xxx0	Slave Interrupt Control	RW
0000 0000 101x xxx1	Slave Interrupt Mask	RW

Note that not all address bits are decoded.

The Slave Interrupt Controller is compatible with the Intel 8259 Interrupt Controller chip. Detailed descriptions of 8259 Interrupt Controller operation can be obtained from the Intel Peripheral Components Data Book and numerous other industry publications.

Interrupt Controller Shadow Registers

The following shadow registers are enabled by setting function 0 Rx47[4]. If the shadow registers are enabled, they are read back at the indicated I/O port instead of the standard interrupt controller registers (writes are unchanged).

Port 20 - Master Interrupt Control Shadow RO
Port A0 - Slave Interrupt Control Shadow RO

7	Reservedalways reads 0
6	OCW3 bit 2 (POLL)	
5	OCW3 bit 0 (RIS)	
4	OCW3 bit 5 (SMM)	
3	OCW2 bit 7 (R)	
2	ICW4 bit 4 (SFNM)	
1	ICW4 bit 1 (AEOI)	
0	ICW1 bit 3 (LTIM)	

Port 21 - Master Interrupt Mask Shadow RO
Port A1 - Slave Interrupt Mask Shadow RO

7-5	Reservedalways reads 0
4-0	T7-T3 of Interrupt Vector Address	

Timer / Counter Registers

Ports 40-43 - Timer / Counter I/O Registers

There are 4 Timer / Counter registers:

<u>I/O Address Bits 15-0</u>	<u>Register Name</u>	
0000 0000 010x xx00	Timer / Counter 0 Count	RW
0000 0000 010x xx01	Timer / Counter 1 Count	RW
0000 0000 010x xx10	Timer / Counter 2 Count	RW
0000 0000 010x xx11	Timer / Counter Cmd Mode	WO

Note that not all bits of the address are decoded.

The Timer / Counters are compatible with the Intel 8254 Timer / Counter chip. Detailed descriptions of 8254 Timer / Counter operation can be obtained from the Intel Peripheral Components Data Book and numerous other industry publications.

Timer / Counter Shadow Registers

The following shadow registers are enabled for readback by setting function 0 Rx47[4]. If the shadow registers are enabled, they are read back at the indicated I/O port instead of the standard timer / counter registers (writes are unchanged).

Port 40 – Counter 0 Base Count Value (LSB 1st MSB 2nd)RO
Port 41 – Counter 1 Base Count Value (LSB 1st MSB 2nd)RO
Port 42 – Counter 2 Base Count Value (LSB 1st MSB 2nd)RO

CMOS / RTC I/O Registers

Port 70 - CMOS Address.....RW

- 7 **NMI Disable** RW
 - 0 Enable NMI Generation. NMI is asserted on encountering SERR# on the PCI bus.
 - 1 Disable NMI Generation.....default
- 6-0 **CMOS Address** (lower 128 bytes) RW

Port 71 - CMOS Data.....RW

7-0 **CMOS Data** (128 bytes)

Note: Ports 70-71 may be accessed if Rx5A bit-2 is set to one to select the internal RTC. If Rx5A bit-2 is set to zero, accesses to ports 70-71 will be directed to an external RTC.

Port 74 - CMOS Address.....RW

7-0 **CMOS Address** (256 bytes) RW

Port 75 - CMOS Data.....RW

7-0 **CMOS Data** (256 bytes)

Note: Ports 74-75 may be accessed only if Function 0 Rx5B bit-1 is set to one to enable the internal RTC SRAM and if Rx48 bit-3 (Port 74/75 Access Enable) is set to one to enable port 74/75 access.

Note: Ports 70-71 are compatible with PC industry-standards and may be used to access the lower 128 bytes of the 256-byte on-chip CMOS RAM. Ports 74-75 may be used to access the full on-chip extended 256-byte space in cases where the on-chip RTC is disabled.

Note: The system Real Time Clock (RTC) is part of the “CMOS” block. The RTC control registers are located at specific offsets in the CMOS data area (0-0Dh and 7D-7Fh). Detailed descriptions of CMOS / RTC operation and programming can be obtained from the VIA VT82887 Data Book or numerous other industry publications. For reference, the definition of the RTC register locations and bits are summarized in the following table:

Offset	Description	Binary Range	BCD Range
00	Seconds	00-3Bh	00-59h
01	Seconds Alarm	00-3Bh	00-59h
02	Minutes	00-3Bh	00-59h
03	Minutes Alarm	00-3Bh	00-59h
04	Hours	am 12hr: 01-1Ch pm 12hr: 81-8Ch 24hr: 00-17h	01-12h 81-92h 00-23h
05	Hours Alarm	am 12hr: 01-1Ch pm 12hr: 81-8Ch 24hr: 00-17h	01-12h 81-92h 00-23h
06	Day of the Week	Sun=1: 01-07h	01-07h
07	Day of the Month	01-1Fh	01-31h
08	Month	01-0Ch	01-12h
09	Year	00-63h	00-99h

0A Register A

- 7 **UIP** Update In Progress
- 6-4 **DV2-0** Divide (010=ena osc & keep time)
- 3-0 **RS3-0** Rate Select for Periodic Interrupt

0B Register B

- 7 **SET** Inhibit Update Transfers
- 6 **PIE** Periodic Interrupt Enable
- 5 **AIE** Alarm Interrupt Enable
- 4 **UIE** Update Ended Interrupt Enable
- 3 **SQWE** No function (read/write bit)
- 2 **DM** Data Mode (0=BCD, 1=binary)
- 1 **24/12** Hours Byte Format (0=12, 1=24)
- 0 **DSE** Daylight Savings Enable

0C Register C

- 7 **IRQF** Interrupt Request Flag
- 6 **PF** Periodic Interrupt Flag
- 5 **AF** Alarm Interrupt Flag
- 4 **UF** Update Ended Flag
- 3-0 **0** Unused (always read 0)

0D Register D

- 7 **VRT** Reads 1 if VBAT voltage is OK
- 6-0 **0** Unused (always read 0)

0E-7C Software-Defined Storage Registers (111 Bytes)

Offset	Extended Functions	Binary Range	BCD Range
7D	Date Alarm	01-1Fh	01-31h
7E	Month Alarm	01-0Ch	01-12h
7F	Century Field	13-14h	19-20h

80-FF Software-Defined Storage Registers (128 Bytes)

Table 9. CMOS Register Summary

Keyboard / Mouse Wakeup Index / Data Registers

The Keyboard / Mouse Wakeup registers are accessed by performing I/O operations to / from an index / data pair of registers in system I/O space at port addresses 2Eh and 2Fh. The registers accessed using this mechanism are used to initialize Keyboard / Mouse Wakeup functions at index values in the range of E0-EF.

Keyboard / Mouse Wakeup initialization is accomplished in three steps:

- 1) Enter initialization mode (set Function 0 Rx51[1] = 1)
- 2) Initialize the chip
 - a) Write index to port 2Eh
 - b) Read / write data from / to port 2Fh
 - c) Repeat a and b for all desired registers
- 3) Exit initialization mode (set Function 0 Rx51[1] = 0)

Port 2Eh – Keyboard Wakeup Index.....RW

7-0 Index Value

Function 0 PCI configuration space register Rx51[1] must be set to 1 to enable access to the configuration registers.

Port 2Fh – Keyboard Wakeup Data.....RW

7-0 Data Value

Keyboard / Mouse Wakeup Registers

These registers are accessed via the port 2E / 2F index / data register pair with Function 0 Rx51[1] = 1 using the indicated index values below

Index E0 – Keyboard / Mouse Wakeup Enable (08h)....RW

- 7-5 **Reserved** always reads 0
- 4 **Reserved (Do Not Program)**..... default = 0
- 3 **Win98 Keyboard Power Key Wake-up**
 - 0 Disable
 - 1 Enabledefault
- 2 **Password Wake-up**
 - 0 Disabledefault
 - 1 Enable
- 1 **PS/2 Mouse Wake-up**
 - 0 Disabledefault
 - 1 Enable
- 0 **Keyboard Wake-up**
 - 0 Disabledefault
 - 1 Enable

Index E1 – Keyboard Wakeup Scan Code Set 0 (F0h).. RW

- 7-0 **Keyboard Wakeup First Scan Code** def = F0h

Index E2 – Keyboard Wakeup Scan Code Set 1 (00h).. RW

- 7-0 **Keyboard Wakeup Second Scan Code** def = 00h

Index E3 – Keyboard Wakeup Scan Code Set 2 (00h).. RW

- 7-0 **Keyboard Wakeup Third Scan Code** def = 00h

Index E4 – Keyboard Wakeup Scan Code Set 3 (00h).. RW

- 7-0 **Keyboard Wakeup Fourth Scan Code** def = 00h

Index E5 – Keyboard Wakeup Scan Code Set 4 (00h).. RW

- 7-0 **Keyboard Wakeup Fifth Scan Code** def = 00h

Index E6 – Keyboard Wakeup Scan Code Set 5 (00h).. RW

- 7-0 **Keyboard Wakeup Sixth Scan Code** def = 00h

Index E7 – Keyboard Wakeup Scan Code Set 6 (00h).. RW

- 7-0 **Keyboard Wakeup Seventh Scan Code** def = 00h

Index E8 – Keyboard Wakeup Scan Code Set 7 (00h).. RW

- 7-0 **Keyboard Wakeup Eighth Scan Code** def = 00h

Index E9 –Mouse Wakeup Scan Code Set 1 (09h)..... RW

- 7-0 **Mouse Wakeup Scan Code Set 1** def = 09h

Index EA –Mouse Wakeup Scan Code Set 2(00h)..... RW

- 7-0 **Mouse Wakeup Scan Code Set 2** def = 00h

Index EB –Mouse Wakeup Scan Code Mask (00h)..... RW

- 7-0 **Mouse Wakeup Scan Code Mask** def = 00h

Memory Mapped I/O APIC Registers

Memory Address FEC0000 – APIC Index.....RW

7-0 APIC Index default = 00h
8-bit pointer to APIC registers.

Memory Address FEC0013-10 – APIC Data.....RW

31-0 APIC Data default = 0000 0000h
Data for the APIC register pointed to by the APIC index

Memory Address FEC0020 – APIC IRQ Pin AssertionWO

7-5 Reserved always reads 0
4-0 APIC IRQ Number.....default undefined
IRQ # for this interrupt. Valid values are 0-23 only.

Memory Address FEC0040 – APIC EOI.....WO

7-0 Redirection Entry Clear.....default undefined
When a write is issued to this register, the APIC will check this field and compare it with the vector field for each entry in the I/O redirection table. When a match is found, the “Remote_IRR” bit for that I/O Redirection Entry will be cleared.

Indexed I/O APIC Registers

Offset 0 – APIC Identification (0000 0000h)..... RW

31-28 Reservedalways reads 0
27-24 APIC Identification..... default = 0
Software must program this value before using the APIC.
23-0 Reservedalways reads 0

Offset 1 – APIC Version (00178002)..... RO

31-24 Reservedalways reads 00h
23-16 Maximum Redirection.....always reads 17h
Equal to the number of APIC interrupt pins minus one. For this APIC, this value is 17h (23 decimal).
15 PCI IRQ
Always reads 1 to indicate that the IRQ assertion register is implemented and that PCI devices are allowed to write to it to cause interrupts.
14-8 Reservedalways reads 0
7-0 APIC Version.....always reads 02h
The implementation version for this APIC is 02h.

Offset 2 – APIC Arbitration (0000 0000h)..... RO

31-28 Reservedalways reads 00h
27-24 APIC Arbitration ID.....always reads 00h
23-0 Reservedalways reads 00h

Offset 3 – Boot Configuration (0000 0000h)..... RW

31-1 Reservedalways reads 00h
0 Interrupt Delivery Mechanism
0 APIC Serial Bus default
1 Front Side Bus Message

Offset 3F-10 – I/O Redirection Table

This table contains 24 registers, with one dedicated table entry for each of the 24 APIC interrupt signals. Each 64-bit register consists of two 32-bit values at consecutive index locations, with the low 32 bits at the even index and the upper 32 bits at the odd index. The default value for all registers is xxx1 xxxx xxxx xxxh.

- Offset 11-10 – I/O Redirection – APIC IRQ0 RW**
- Offset 13-12 – I/O Redirection – APIC IRQ1 RW**
- Offset 15-14 – I/O Redirection – APIC IRQ2 RW**
- Offset 17-16 – I/O Redirection – APIC IRQ3 RW**
- Offset 19-18 – I/O Redirection – APIC IRQ4 RW**
- Offset 1B-1A – I/O Redirection – APIC IRQ5..... RW**
- Offset 1D-1C – I/O Redirection – APIC IRQ6 RW**
- Offset 1F-1E – I/O Redirection – APIC IRQ7 RW**
- Offset 21-20 – I/O Redirection – APIC IRQ8 RW**
- Offset 23-22 – I/O Redirection – APIC IRQ9 RW**
- Offset 25-24 – I/O Redirection – APIC IRQ10 RW**
- Offset 27-26 – I/O Redirection – APIC IRQ11 RW**
- Offset 29-28 – I/O Redirection – APIC IRQ12 RW**
- Offset 2B-2A – I/O Redirection – APIC IRQ13..... RW**
- Offset 2D-2C – I/O Redirection – APIC IRQ14 RW**
- Offset 2F-2E – I/O Redirection – APIC IRQ15 RW**
- Offset 31-30 – I/O Redirection – APIC IRQ16 RW**
- Offset 33-32 – I/O Redirection – APIC IRQ17 RW**
- Offset 35-34 – I/O Redirection – APIC IRQ18 RW**
- Offset 37-36 – I/O Redirection – APIC IRQ19 RW**
- Offset 39-38 – I/O Redirection – APIC IRQ20 RW**
- Offset 3B-3A – I/O Redirection – APIC IRQ21..... RW**
- Offset 3D-3C – I/O Redirection – APIC IRQ22 RW**
- Offset 3F-3E – I/O Redirection – APIC IRQ23 RW**

Format for Each I/O Redirection Table Entry:

Physical Mode (bit-11=0)

- 63-60 Reserved**always reads 0
- 59-56 APIC ID** default = undefined

Logical Mode (bit-11=1)

- 63-56 Destination** default = undefined

- 55-17 Reserved**always reads 0

16 Interrupt Masked

- 0 Not masked..... default
- 1 Masked

15 Trigger Mode

- 0 Edge Sensitive default
- 1 Level Sensitive

14 Remote IRR (Level Sensitive Interrupts Only) RO

- 0 EOI message with a matching interrupt vector received from a local APIC
- 1 Level sensitive interrupt sent by IOAPIC accepted by local APIC(s)

13 Interrupt Input Pin Polarity

- 0 Active High default
- 1 Active Low

12 Delivery Status..... RO

Contains the current status of the delivery of this interrupt.

- 0 Idle (no activity)
- 1 Send Pending (the interrupt has been injected but its delivery is temporarily delayed either because the APIC bus is busy or because the receiving APIC unit cannot currently accept the interrupt)

11 Destination Mode

Determines the interpretation of bits 56-63.

- 0 Physical Mode default
- 1 Logical Mode

10-8 Delivery Mode

Specifies how the APICs listed in the destination field should act upon reception of this signal

- 000 Fixed default
- 001 Lowest Priority
- 010 SMI
- 011 -reserved-
- 100 NMI
- 101 INIT
- 110 -reserved-
- 111 External INT

7-0 Interrupt Vector

Contains the interrupt vector for this interrupt. Vector values range from 10h to FEh.

Configuration Space I/O

Configuration space accesses for all functions use PCI configuration mechanism 1 (see PCI specification revision 2.2 for more details). The ports respond only to double-word accesses. Byte or word accesses will be passed on unchanged.

There are 8 “functions” implemented in the VT8233A (see Table 5 on page 20). The following sections describe the registers and register bits of these functions.

Port CFB-CF8 - Configuration AddressRW

- 31 Configuration Space Enable**
 - 0 Disableddefault
 - 1 Convert configuration data port writes to configuration cycles on the PCI bus
- 30-24 Reserved** always reads 0
- 23-16 PCI Bus Number**
Used to choose a specific PCI bus in the system
- 15-11 Device Number**
Used to choose a specific device in the system
- 10-8 Function Number**
Used to choose a specific function if the selected device supports multiple functions
- 7-2 Register Number**
Used to select a specific doubleword in the device’s configuration space
- 1-0 Fixed** always reads 0

Port CFF-CFC - Configuration DataRW

Device 17 Function 0 Registers – Bus Control and Power Management

All registers are located in the device 17 function 0 configuration space of the VT8233A. These registers are accessed through PCI configuration mechanism #1 via I/O address 0CF8h / 0CFCh.

PCI Configuration Space Header

Offset 1-0 - Vendor ID (1106h)RO

Offset 3-2 - Device ID (3147h).....RO

Offset 5-4 - Command..... RW

- 15-8 **Reserved** always reads 0
- 7 **Address / Data Stepping**
 - 0 Disable
 - 1 Enabledefault
- 6-4 **Reserved** always reads 0
- 3 **Special Cycle Enable**Normally RW, default = 0
- 2 **Bus Master** always reads 1
- 1 **Memory Space**..... Normally RO, reads as 1
- 0 **I/O Space** Normally RO, reads as 1

Offset 7-6 - StatusRWC

- 15 **Detected Parity Error**write one to clear
- 14 **Signalled System Error**.....always reads 0
- 13 **Signalled Master Abort**.....write one to clear
- 12 **Received Target Abort**.....write one to clear
- 11 **Signalled Target Abort**write one to clear
- 10-9 **DEVSEL# Timing**fixed at 01 (medium)
- 8 **Data Parity Detected**always reads 0
- 7 **Fast Back-to-Back**always reads 0
- 6-0 **Reserved**always reads 0

Offset 8 - Revision ID (nnh)..... RO

- 7-0 **Revision ID** always reads nnh

Offset 9 - Program Interface (00h)..... RO

Offset A - Sub Class Code (01h)..... RO

Offset B - Class Code (06h)..... RO

Offset E - Header Type (80h) RO

- 7-0 **Header Type Code**..... 80h (Multifunction Device)

Offset F - BIST (00h)..... RO

Offset 2F-2C - Subsystem ID RO

Use offset 70-73 to change the value returned.

ISA Bus Control

Offset 40 - ISA Bus Control (00h)..... RW

- 7 **Reserved** always reads 0
- 6 **I/O Recovery Time**
The number of clocks between 2 I/O commands
 - 0 Disabledefault
 - 1 Enable (Rx4C[7:6] determines the # of clocks)
- 5 **ROM Wait States**
 - 0 1 Wait State.....default
 - 1 0 Wait States
- 4 **ROM Write**
 - 0 Disable (ROM writes are ignored).....default
 - 1 Enable (ROM can be written)
- 3 **Double DMA Clock**
 - 0 DMA clock runs at 4 MHz.....default
 - 1 DMA clock runs at 8 MHz
- 2 **4D0 / 4D1 Port Configuration**
Controls whether ports 4D0 / 4D1 can be configured. Ports 4D0 / 4D1 determine whether IRQ requests are edge or level triggered (4D0[7-0] for IRQ7-0, 4D1[7-0] for IRQ15-8) (0 = level, 1 = edge).
 - 0 Disabledefault
 - 1 Enable
- 1 **DMA / Interrupt / Timer Shadow Register Read**
 - 0 Disabledefault
 - 1 Enable (shadow register values can be read)
- 0 **Double ISA Bus Clock**
 - 0 Bus clock runs at PCLK / 4 (8 MHz).....default
 - 1 Bus clock runs at PCLK / 2 (16 MHz)

Offset 41 – BIOS ROM Decode Control (00h)..... RW

Setting these bits to 1 enables the indicated address range to be included in the ROMCS# decode:

- 7 **Reserved** always reads 0
- 6 **FFF0000h-FFF7FFFFh** default=0 (disable)
- 5 **FFE8000h-FFEFFFFFFh** default=0 (disable)
- 4 **FFE0000h-FFE7FFFFh**..... default=0 (disable)
- 3 **FFD8000h-FFDFFFFFFh** default=0 (disable)
- 2 **FFD0000h-FFD7FFFFh** default=0 (disable)
- 1 **FFC8000h-FFCFFFFFFh** default=0 (disable)
- 0 **FFC0000h-FFC7FFFFh** default=0 (disable)

Note: ROMCS# is always active when ISA addresses FFF80000-FFFFFFF and 000E0000-00FFFFFF are decoded.

Offset 42 – Line Buffer Control (00h)..... RW

- 7 **ISA Master DMA Line Buffer**
Controls whether the DMA line buffer is used.
 - 0 Disable..... default
 - 1 Enable. Master DMA waits until the line buffer is full (8 DWords) before transmitting data (bit-6 must also be enabled to insure that there are no coherency issues).
- 6 **Gate Interrupt Until Line Buffer Flush Complete**
This bit should be enabled if bit-7 is enabled.
 - 0 Disable..... default
 - 1 Enable. IRQs are gated until the line buffer is flushed to insure that there are no coherency issues.
- 5 **Flush Line Buffer for Interrupt**
This bit controls whether the line bufer is flushed when an interrupt request is generated. This bit should be enabled if bit-7 is enabled.
 - 0 Disable..... default
 - 1 Enable
- 4 **Uninterruptable Burst Read**
 - 0 Disable..... default
 - 1 Enable. The PCI bus is not granted to DMA until burst read transactions from the north bridge are completed.
- 3-0 **Reserved**always reads 0

Offset 43 – Delay Transaction Control (00h) RW

- 7-4 **Reserved (Do Not Program)** default = 0
- 3 **Delayed Transactions (PCI Spec Rev 2.1)**
This bit controls whether delayed transactions (delayed read / write and posted write) are enabled.
 - 0 Disable..... default
 - 1 Enable
- 2 **Only Posted Write**
This bit controls whether posted write is enabled, as opposed to bit-3 which controls whether delayed read / write as well as posted write are enabled.
 - 0 Disable..... default
 - 1 Enable
- 1 **Write Delay Transaction Timeout Timer**
When enabled, if a delayed transaction (write cycle only) is not retried after 2¹² PCI clocks, the transaction is terminated.
 - 0 Disable..... default
 - 1 Enable
- 0 **Read Delay Transaction Timeout Timer**
When enabled, if a delayed transaction (read cycle only) is not retried after 2¹² PCI clocks, the transaction is terminated.
 - 0 Disable..... default
 - 1 Enable

Offset 48 – Read Pass Write Control.....RW

- 7 APIC FSB Address Bit-2 Mask**
 - 0 Disable (A2 not masked).....default
 - 1 Enable (force A2 from APIC FSB to low)

Address bit A2 controls whether data is in the lower (0) or upper (1) doubleword of a quadword sent to the CPU. When this bit is enabled, A2 is masked which means it is always 0 to select the lower doubleword.
- 6-4 Reserved** always reads 0
- 3 AC97 / LPC Read Pass Write**
 - 0 Disable (a read cannot be performed before a preceeding write has been completed) ...default
 - 1 Enable (internal AC97 and LPC devices are allowed to perform a read before a preceeding write)
- 2 IDE Read Pass Write**
 - 0 Disable (a read cannot be performed before a preceeding write has been completed) ...default
 - 1 Enable (the internal IDE controller is allowed to perform a read before a preceeding write)
- 1 USB Read Pass Write**
 - 0 Disable (a read cannot be performed before a preceeding write has been completed) ...default
 - 1 Enable (the internal USB controllers are allowed to perform a read before a preceeding write)
- 0 Reserved** always reads 0

Offset 49 – CCA Control..... RW

- 7 Reserved**always reads 0
- 6 South Bridge Internal Master Devices Priority Higher Than External PCI Master**
 - 0 Disable..... default
 - 1 Enable

The “CCA” is an internal arbiter that controls the priority of external PCI masters vs. internal master devices. Normally priority is the same for internal and external PCI master devices, but when this bit is enabled, internal master devices are given higher priority than external PCI masters (3/4 : 1/4).
- 5 CCA Clean to Mask Off IRQ**

Controls whether interrupt requests are gated until data is written to memory.

 - 0 Disable..... default
 - 1 Enable
- 4-3 Reserved (Do Not Program)**..... default = 0
- 2 WSC Mask Off INTR**

Controls whether INTR is masked until write snoop is complete.

 - 0 Disable..... default
 - 1 Enable
- 1-0 Reserved (Do Not Program)**..... default = 0

Miscellaneous Control

Offset 4C - IDE Interrupt Routing (04h) RW

- 7-6 I/O Recovery Time Select**
When Rx40[6] is enabled, this field determines the I/O recovery time.
 - 00 1 Bus Clock.....default
 - 01 2 Bus Clock
 - 10 4 Bus Clock
 - 11 8 Bus Clock
- 5-4 Reserved (do not program)..... default = 0**
- 3-2 IDE Secondary Channel IRQ Routing**
 - 00 IRQ14
 - 01 IRQ15.....default
 - 10 IRQ10
 - 11 IRQ11
- 1-0 IDE Primary Channel IRQ Routing**
 - 00 IRQ14.....default
 - 01 IRQ15
 - 10 IRQ10
 - 11 IRQ11

VT8233 Version CE:

Offset 4D – External APIC IRQ Output Control..... RW

- 7 IDE IRQ to APIC[23:16] with F1/Rx3C[2:0]**
 - 6 USB P4-5 IRQ to APIC[23:16] with F4/Rx3C[2:0]**
 - 5 LAN IRQ to APIC[23:16] with D0/F0/Rx3C[2:0]**
 - 4 Reserved always reads 0**
 - 3 MC97 IRQ to APIC[23:16] with F6/Rx3C[2:0]**
 - 2 AC97 IRQ to APIC[23:16] with F5/Rx3C[2:0]**
 - 1 USB P2-3 IRQ to APIC[23:16] with F3/Rx3C[2:0]**
 - 0 USB P0-1 IRQ to APIC[23:16] with F2/Rx3C[2:0]**
- All bits except bit-4:
- 0 Disabledefault
 - 1 Enable

VT8233A:

Offset 4D – Reserved..... RW

In the VT8233A, IRQ Routing to the APIC is fixed as follows:

- INTA# => IRQ16
- INTB# => IRQ17
- INTC# => IRQ18
- INTD# => IRQ19
- IDE IRQ => IRQ20
- USB1 IRQ => IRQ21
- USB2 IRQ => IRQ21 if Rx59[5] = 0
=> IRQ23 if Rx59[5] = 1
- AC97 / MC97 IRQ => IRQ22

Offset 4E - Internal RTC Test Mode RW

- 7-5 Reservedalways reads 0**
- 4 Last Port 70/74 Written Status**
 - 0 Last write was to port 70 default
 - 1 Last write was to port 74
- 3 Extra RTC Port 74/75**
The RTC is normally accessed though ports 70/74. This bit controls whether two extra ports (74 / 75) can be used to access the RTC.
 - 0 Disable..... default
 - 1 Enable
- 2-0 Reserved (Do Not Program)..... default = 0**

Offset 4F – PCI Bus and CPU Interface Control..... RW

- 7-4 Reservedalways reads 0**
- 3 CPU Reset Source**
This bit determines whether CPU Reset (generated through port 92 or the keyboard) uses INIT or CPURST.
 - 0 Use CPURST as CPU Reset..... default
 - 1 Use INIT as CPU Reset
- 2 Reserved (Do Not Program)..... default = 0**
- 1 Reservedalways reads 0**
- 0 Software PCI Resetwrite 1 to generate PCI reset**

Function Control

Offset 50 – Function Control 1 (09h).....RW

- 7 Function 6 MC97**
 - 0 Enabledefault
 - 1 Disable
- 6 Function 5 AC97**
 - 0 Enabledefault
 - 1 Disable
- 5 Function 3 USB Ports 2-3**
 - 0 Enabledefault
 - 1 Disable
- 4 Function 2 USB Ports 0-1**
 - 0 Enabledefault
 - 1 Disable
- 3 Function 1 IDE**
 - 0 Enable
 - 1 Disable**default**
- 2-0 Reserved** always reads 0
(Bit-2 is Function 4 USB Port 4-5 Disable in VT8233 and VT8233C)

Offset 51 – Function Control 2 (0Dh).....RW

- 7-4 Reserved** always reads 0
(Bits 5-4 are LAN control bits in VT8233/VT8233C)
- 3 Internal RTC**
 - 0 Disable
 - 1 Enable**default**
- 2 Internal PS2 Mouse**
 - 0 Disable
 - 1 Enable**default**
- 1 Internal KBC Configuration**
 - 0 Disable ports 2E / 2F offsets E0-EFdefault
 - 1 Enable ports 2E / 2F offsets E0-EF
- 0 Internal KBC**
 - 0 Disable
 - 1 Enable**default**

	0 / Disable	1 / Enable
<u>Pin</u>	<u>(External KBC)</u>	<u>(Internal KBC)</u>
W10	KBCS#	ROMCS#
N2	KBRC	KBDT
N1	KA20G	KBCK
M2	IRQ12	MSDT
N3	IRQ1	MSCK

Serial IRQ, LPC, and PC/PCI DMA Control

Offset 52 – Serial IRQ & LPC Control (00h)..... RW

- 7 Reserved**always reads 0
- 6 LPC Short Wait Abort**
 - 0 Disable..... default
 - 1 Enable. During a short wait, the cycle is aborted after 8Ts.
- 5 LPC Frame Wait State Time**
 - 0 Frame Wait State is 1T default
 - 1 Frame Wait State is 2T
- 4 LPC Stop to Start Frame Wait State**
 - 0 Enable. One idle state is inserted between Stop and Start default
 - 1 Disable. Stop is followed immediately by Start.
- 3 Serial IRQ**
 - 0 Disable..... default
 - 1 Enable (IRQ Asserted via Serial IRQ Pin W8)
- 2 Serial IRQ Quiet Mode**
 - 0 Continuous Mode default
 - 1 Quiet Mode
- 1-0 Serial IRQ Start-Frame Width**
 - 00 4 PCI Clocks..... default
 - 01 6 PCI Clocks
 - 10 8 PCI Clocks
 - 11 10 PCI Clocks

Plug and Play Control - PCI

Offset 54 - PCI Interrupt PolarityRW

7-4 **Reserved** always reads 0

The following bits all default to “level” triggered (0)

3 **PCI INTA# Invert (edge) / Non-invert (level) . (1/0)**

2 **PCI INTB# Invert (edge) / Non-invert (level).. (1/0)**

1 **PCI INTC# Invert (edge) / Non-invert (level) . (1/0)**

0 **PCI INTD# Invert (edge) / Non-invert (level) . (1/0)**

Note: PCI INTA-D# normally connect to PCI interrupt pins INTA-D# (see pin definitions for more information).

Offset 55 – PCI PNP Interrupt Routing 1.....RW

7-4 **PCI INTA# Routing** (see PnP IRQ routing table)

3-0 **Reserved** always reads 0

Offset 56 – PCI PNP Interrupt Routing 2.....RW

7-4 **PCI INTC# Routing** (see PnP IRQ routing table)

3-0 **PCI INTB# Routing** (see PnP IRQ routing table)

Offset 57 – PCI PNP Interrupt Routing 3.....RW

7-4 **PCI INTD# Routing** (see PnP IRQ routing table)

3-0 **Reserved** always reads 0

Table 10. PnP IRQ Routing Table

0000	Disabled.....	default
0001	IRQ1	
0010	Reserved	
0011	IRQ3	
0100	IRQ4	
0101	IRQ5	
0110	IRQ6	
0111	IRQ7	
1000	Reserved	
1001	IRQ9	
1010	IRQ10	
1011	IRQ11	
1100	IRQ12	
1101	Reserved	
1110	IRQ14	
1111	IRQ15	

GPIO and Miscellaneous Control

Offset 58 – Miscellaneous Control 0 (40h) RW

- 7 Reserved** always reads 0
- 6 Internal APIC**
 - 0 Disable
 - 1 Enabledefault
- 5 Reserved** always reads 0
- 4 Address Decode**
 - 0 Subtractivedefault
 - 1 Positive
- 3 RTC High Bank Access**
 - 0 Disable access to upper 128 bytes.....default
 - 1 Enable access to upper 128 bytes
- 2 RTC Rx32 Write Protect**
 - 0 Disable (not protected).....default
 - 1 Enable (write protected)
- 1 RTC Rx0D Write Protect**
 - 0 Disable (not protected).....default
 - 1 Enable (write protected)
- 0 RTC Rx32 Map to Century Byte**
Controls whether RTC Rx32 is mapped to the century byte.
 - 0 Disabledefault
 - 1 Enable

Offset 59 – Miscellaneous Control 1 (00h) RW

- 7-6 Reserved** always reads 0
- 5 USB Controller 2 (Ports 2-3) IRQ Routing**
 - 0 Route USB2 IRQ to APIC IRQ21default
 - 1 Route USB2 IRQ to APIC IRQ23

(Bit 5 is APIC Specification 1.4 Compatibility Enable in the VT8233 and VT8233C)
- 4 LPC Keyboard**
 - 0 Disable (ISA Keyboard).....default
 - 1 Enable (LPC Keyboard)
- 3 External M CCS to LPC**
Controls whether external M CCS is through LPC or ISA when internal M CCS is not used.
 - 0 Disable (ISA M CCS)default
 - 1 Enable (LPC M CCS)
- 2 Internal M CCS (Microcontroller Chip Select)**
 - 0 Disable (external M CCS).....default
 - 1 Enable (internal M CCS)
- 1 A20M# Active**
 - 0 Disable (A20M# signal not asserted)default
 - 1 Enable (A20M# signal asserted)
- 0 NMI on PCI Parity Error**
 - 0 Disabledefault
 - 1 Enable (to generate NMI, Port 61[3] and Port 70[7] must also be set)

Offset 5A – DMA Bandwidth Control (00h) RW

- 7 DMA Channel 7 Bandwidth**
 - 0 Normal..... default
 - 1 Improved
- 6 DMA Channel 6 Bandwidth**
 - 0 Normal..... default
 - 1 Improved
- 5 DMA Channel 5 Bandwidth**
 - 0 Normal..... default
 - 1 Improved
- 4 DMA Single Transfer Mode Bandwidth**
 - 0 Normal..... default
 - 1 Improved
- 3 DMA Channel 3 Bandwidth**
 - 0 Normal..... default
 - 1 Improved
- 2 DMA Channel 2 Bandwidth**
 - 0 Normal..... default
 - 1 Improved
- 1 DMA Channel 1 Bandwidth**
 - 0 Normal..... default
 - 1 Improved
- 0 DMA Channel 0 Bandwidth**
 - 0 Normal..... default
 - 1 Improved

The above bits determine if DMA bandwidth is improved for the specified channel. If enabled, bandwidth improvement is accomplished by reducing the transaction latency between the DMA Controller and the LPC Bus Controller.

Programmable Chip Select Control

Offset 5D-5C – PCS 0 I/O Port Address (0000h).....RW

15-0 PCS 0 I/O Port Address default = 0

Offset 5F-5E – PCS 1 I/O Port Address (0000h)RW

15-0 PCS 1 I/O Port Address default = 0

Offset 61-60 – PCS 2 I/O Port Address (0000h)RW

15-0 PCS 2 I/O Port Address default = 0

Offset 63-62 – PCS 3 I/O Port Address (0000h)RW

15-0 PCS 3 I/O Port Address default = 0

Offset 65-64 – PCS I/O Port Address Mask (0000h).....RW

15-12 PCS 3 I/O Port Address Mask 3-0

- 0000 Decode range is 1 bytedefault
- 0001 Decode range is 2 bytes
- 0011 Decode range is 4 bytes
- 0111 Decode range is 8 bytes
- 1111 Decode range is 16 bytes

11-8 PCS 2 I/O Port Address Mask 3-0

- 0000 Decode range is 1 bytedefault
- 0001 Decode range is 2 bytes
- 0011 Decode range is 4 bytes
- 0111 Decode range is 8 bytes
- 1111 Decode range is 16 bytes

7-4 PCS 1 I/O Port Address Mask 3-0

- 0000 Decode range is 1 bytedefault
- 0001 Decode range is 2 bytes
- 0011 Decode range is 4 bytes
- 0111 Decode range is 8 bytes
- 1111 Decode range is 16 bytes

3-0 PCS 0 I/O Port Address Mask 3-0

- 0000 Decode range is 1 bytedefault
- 0001 Decode range is 2 bytes
- 0011 Decode range is 4 bytes
- 0111 Decode range is 8 bytes
- 1111 Decode range is 16 bytes

Offset 66 – PCS Control (00h)..... RW

7 PCS 3 Internal I/O

- 0 Disable (External)..... default
- 1 Enable (Internal)

6 PCS 2 Internal I/O

- 0 Disable (External)..... default
- 1 Enable (Internal)

5 PCS 1 Internal I/O

- 0 Disable (External)..... default
- 1 Enable (Internal)

4 PCS 0 Internal I/O

- 0 Disable (External)..... default
- 1 Enable (Internal)

The above 4 bits determine whether Programmable Chip Selects 0-3 are treated as internal I/O

3 PCS 3

- 0 Disable..... default
- 1 Enable

2 PCS 2

- 0 Disable..... default
- 1 Enable

1 PCS 1

- 0 Disable..... default
- 1 Enable

0 PCS 0

- 0 Disable..... default
- 1 Enable

Offset 67 – Output Control (04h) RW

7-3 Reservedalways reads 0

2 FERR Voltage

- 0 2.5V
- 1 1.5V **default**

1-0 Reservedalways reads 0

ISA Decoding Control

Offset 6C – ISA Positive Decoding Control 1RW

- 7 On-Board I/O (Ports 00-FFh) Positive Decoding**
 - 0 Disabledefault
 - 1 Enable
- 6 Microsoft-Sound System I/O Port Positive Decoding**
 - 0 Disabledefault
 - 1 Enable (bits 5-4 determine the decode range)
- 5-4 Microsoft-Sound System I/O Decode Range**
 - 00 0530h-0537hdefault
 - 01 0604h-060Bh
 - 10 0E80-0E87h
 - 11 0F40h-0F47h
- 3 Internal APIC Positive Decoding**
 - 0 Disabledefault
 - 1 Enable
- 2 BIOS ROM Positive Decoding**
 - 0 Disabledefault
 - 1 Enable
- 1 Internal PCS1# Positive Decoding**
 - 0 Disabledefault
 - 1 Enable
- 0 Internal PCS0# Positive Decoding**
 - 0 Disabledefault
 - 1 Enable

Offset 6D – ISA Positive Decoding Control 2RW

- 7 FDC Positive Decoding**
 - 0 Disabledefault
 - 1 Enable
- 6 LPT Positive Decoding**
 - 0 Disabledefault
 - 1 Enable
- 5-4 LPT Decode Range**
 - 00 3BCh-3BFh, 7BCh-7BEhdefault
 - 01 378h-37Fh, 778h-77Ah
 - 10 278h-27Fh, 678h-67Ah
 - 11 -reserved-
- 3 Game Port Positive Decoding**
 - 0 Disabledefault
 - 1 Enable
- 2 MIDI Positive Decoding**
 - 0 Disabledefault
 - 1 Enable
- 1-0 MIDI Decode Range**
 - 00 300-303hdefault
 - 01 310-313h
 - 10 320-323h
 - 11 330-333h

Offset 6E – ISA Positive Decoding Control 3 RW

- 7 COM Port B Positive Decoding**
 - 0 Disable..... default
 - 1 Enable
- 6-4 COM-Port B Decode Range**
 - 000 3F8h-3FFh (COM1)..... default
 - 001 2F8h-2FFh (COM2)
 - 010 220h-227h
 - 011 228h-22Fh
 - 100 238h-23Fh
 - 101 2E8h-2EFh (COM4)
 - 110 338h-33Fh
 - 111 3E8h-3EFh (COM3)
- 3 COM Port A Positive Decoding**
 - 0 Disable..... default
 - 1 Enable
- 2-0 COM-Port A Decode Range**
 - 000 3F8h-3FFh (COM1)..... default
 - 001 2F8h-2FFh (COM2)
 - 010 220h-227h
 - 011 228h-22Fh
 - 100 238h-23Fh
 - 101 2E8h-2EFh (COM4)
 - 110 338h-33Fh
 - 111 3E8h-3EFh (COM3)

Offset 6F – ISA Positive Decoding Control 4 RW

- Note: Bits 4 and 5 are reserved in the VT8233 and VT8233C)
- 7-6 Reserved**always reads 0
 - 5 PCS2# and PCS3# Positive Decoding (8233A only)**
 - 0 Disable..... default
 - 1 Enable
 - 4 I/O Port 0CF9h Positive Decoding (8233A only)**
 - 0 Disable..... default
 - 1 Enable
 - 3 FDC Decoding Range**
 - 0 Primary default
 - 1 Secondary
 - 2 Sound Blaster Positive Decoding**
 - 0 Disable..... default
 - 1 Enable
 - 1-0 Sound Blaster Decode Range**
 - 00 220-233h..... default
 - 01 240-253h
 - 10 260-273h
 - 11 280-293h

I/O Pad Control

Offset 7C – I/O Pad Control (00h).....RW

- 7-6 **Reserved** always reads 0
- 5-4 **IDE Interface Output Drive Strength**
 - 00 Lowest.....default
 -
 - 11 Highest
- 3-2 **PLL PCLK Input Delay Select**
 - 00default
 - 01
 - 10
 - 11
- 1-0 **PLL CLK66 Feedback Delay Select**
 - 00default
 - 01
 - 10
 - 11

Power Management-Specific Configuration Registers

Offset 80 – General Configuration 0 RW

- 7 **Reserved** always reads 0
- 6 **Sleep Button**
 - 0 Disable default
 - 1 Sleep Button is on GPI21 / ACSDIN3 pin
- 5 **Debounce LID and PWRBTN# Inputs for 200us**
This bit controls whether the debounce circuit for the LID# and PWRBTN# inputs is enabled to reduce possible noise.
 - 0 Disable default
 - 1 Enable
- 4 **Reserved (Do Not Program)**..... default = 0
- 3 **Microsoft Sound Monitor in Audio Access**
This bit controls whether an I/O access to the sound port sets I/O Rx33-30[10] (Audio Access Status) = 1.
 - 0 Disable default
 - 1 Enable
- 2 **Game Port Monitor in Audio Access**
This bit controls whether an I/O access to the game port sets I/O Rx33-30[10] (Audio Access Status) = 1.
 - 0 Disable default
 - 1 Enable
- 1 **Sound Blaster Monitor in Audio Access**
This bit controls whether an I/O access to the sound blaster port sets I/O Rx33-30[10] (Audio Access Status) = 1.
 - 0 Disable default
 - 1 Enable
- 0 **MIDI Monitor in Audio Access**
This bit controls whether an I/O access to the MIDI port sets I/O Rx33-30[10] (Audio Access Status) = 1.
 - 0 Disable default
 - 1 Enable

Offset 81 - General Configuration 1 RW

- 7 **I/O Enable for ACPI I/O Base**
 - 0 Disable access to ACPI I/O block default
 - 1 Allow access to Power Management I/O Register Block (see offset 4B-48 to set the base address for this register block). The definitions of the registers in the Power Management I/O Register Block are included later in this document, following the Power Management Subsystem overview.
- 6-4 **Reserved** always reads 0
- 3 **ACPI Timer Count Select**
 - 0 24-bit Timer..... default
 - 1 32-bit Timer
- 2 **RTC Enable Signal Gated with PSON (SUSC#) in Soft-Off Mode**
This bit controls whether RTC control signals are gated during system on/off (PWRGD or SUSC# low). This is to prevent the RTC from being accessed during system on/off when the control signals may not be stable.
 - 0 Disable..... default
 - 1 Enable
- 1 **Clock Throttling Clock Select (STPCLK#)**
This bit controls the timer tick base for the throttle timer.
 - 0 30 usec (480 usec cycle time when using a 4-bit timer)..... default
 - 1 1 msec (16 msec cycle time when using a 4-bit timer)

The timer tick base can be further lowered to 7.5 usec (120 usec cycle time when using a 4-bit timer) by setting Rx8D[4] = 1. When Rx8D[4] = 1, the setting of this bit is ignored.
- 0 **Reserved (Do Not Program)**..... default = 0

Offset 82 - ACPI Interrupt Select.....RW

- 7 ATX / AT Power Indicator** RO
 - 0 ATX
 - 1 AT
- 6 SUSC# State** RO
 During system on/off, this status bit reports whether RTC signals are stable (whether the signals are still gated) and controls whether the RTC can be accessed. When this bit equals one, RTC signals are stable and the RTC is ready to be accessed.
- 5 Reserved** always reads 0
- 4 SUSC# AC-Power-On Default Value** RO
 This bit is written at RTC Index 0D bit-7. If this bit is 0, the system is configured to “default on” when power is connected.

3-0 SCI Interrupt Assignment

- This field determines the routing of the ACPI IRQ.
- 0000 Disabled..... default
 - 0001 IRQ1
 - 0010 Reserved
 - 0011 IRQ3
 - 0100 IRQ4
 - 0101 IRQ5
 - 0110 IRQ6
 - 0111 IRQ7
 - 1000 IRQ8
 - 1001 IRQ9
 - 1010 IRQ10
 - 1011 IRQ11
 - 1100 IRQ12
 - 1101 IRQ13
 - 1110 IRQ14
 - 1111 IRQ15

Offset 85-84 - Primary Interrupt Channel (0000h).....RW

If a device IRQ is enabled as a Primary IRQ, that device's IRQ can be used to generate wake events. The bits in this register are used in conjunction with:

- PMIO Rx28[7] – Primary Resume Status
- PMIO Rx2A[7] – Primary Resume Enable

If a device on one of the IRQ's is set to enable the Primary Interrupt, once the device generates an IRQ, the PMIO Rx28[7] status bit will become 1 to report the occurrence of the Primary IRQ. If PMIO Rx2A[7] is set to 1 to enable Resume-on-Primary-IRQ, the IRQ then becomes a wake event.

- | | |
|----|--|
| 15 | 1/0 = Ena/Disa IRQ15 as Primary Intrpt Channel |
| 14 | 1/0 = Ena/Disa IRQ14 as Primary Intrpt Channel |
| 13 | 1/0 = Ena/Disa IRQ13 as Primary Intrpt Channel |
| 12 | 1/0 = Ena/Disa IRQ12 as Primary Intrpt Channel |
| 11 | 1/0 = Ena/Disa IRQ11 as Primary Intrpt Channel |
| 10 | 1/0 = Ena/Disa IRQ10 as Primary Intrpt Channel |
| 9 | 1/0 = Ena/Disa IRQ9 as Primary Intrpt Channel |
| 8 | 1/0 = Ena/Disa IRQ8 as Primary Intrpt Channel |
| 7 | 1/0 = Ena/Disa IRQ7 as Primary Intrpt Channel |
| 6 | 1/0 = Ena/Disa IRQ6 as Primary Intrpt Channel |
| 5 | 1/0 = Ena/Disa IRQ5 as Primary Intrpt Channel |
| 4 | 1/0 = Ena/Disa IRQ4 as Primary Intrpt Channel |
| 3 | 1/0 = Ena/Disa IRQ3 as Primary Intrpt Channel |
| 2 | Reserved always reads 0 |
| 1 | 1/0 = Ena/Disa IRQ1 as Primary Intrpt Channel |
| 0 | 1/0 = Ena/Disa IRQ0 as Primary Intrpt Channel |

Offset 87-86 - Secondary Interrupt Channel (0000h).... RW

For legacy PMU, the bits in this register are used in conjunction with:

- PMIO Rx28[1] – Secondary Event Timer Timeout Status
- PMIO Rx2A[7] – SMI on Secondary Event Timer Timeout

Secondary IRQ's are different from Primary IRQ's in that systems that resume due to a Secondary IRQ can return directly to suspend state after the secondary event timer times out. For this to work, PMIO Rx2A[1] needs to be set to one to enable SMI-on-Secondary-Event-Timer-Timeout (when PMIO Rx28[1] = 1). The timer's count value can be set via Rx93-90[27-26].

- | | |
|----|--|
| 15 | 1/0 = Ena/Disa IRQ15 as Secondary Intr Channel |
| 14 | 1/0 = Ena/Disa IRQ14 as Secondary Intr Channel |
| 13 | 1/0 = Ena/Disa IRQ13 as Secondary Intr Channel |
| 12 | 1/0 = Ena/Disa IRQ12 as Secondary Intr Channel |
| 11 | 1/0 = Ena/Disa IRQ11 as Secondary Intr Channel |
| 10 | 1/0 = Ena/Disa IRQ10 as Secondary Intr Channel |
| 9 | 1/0 = Ena/Disa IRQ9 as Secondary Intr Channel |
| 8 | 1/0 = Ena/Disa IRQ8 as Secondary Intr Channel |
| 7 | 1/0 = Ena/Disa IRQ7 as Secondary Intr Channel |
| 6 | 1/0 = Ena/Disa IRQ6 as Secondary Intr Channel |
| 5 | 1/0 = Ena/Disa IRQ5 as Secondary Intr Channel |
| 4 | 1/0 = Ena/Disa IRQ4 as Secondary Intr Channel |
| 3 | 1/0 = Ena/Disa IRQ3 as Secondary Intr Channel |
| 2 | Reserved always reads 0 |
| 1 | 1/0 = Ena/Disa IRQ1 as Secondary Intr Channel |
| 0 | 1/0 = Ena/Disa IRQ0 as Secondary Intr Channel |

Offset 8B-88 – Power Management I/O BaseRW

- 31-16 **Reserved** always reads 0
- 15-7 **Power Management I/O Register Base Address**
Port Address for the base of the 128-byte Power Management I/O Register block, corresponding to AD[15:7]. See “Power Management I/O Space Registers” in this document for “PMIO” register definitions.
- 6-0 **0000001b**

Offset 8C – Host Bus Power Management Control.....RW

- 7-4 **Thermal Duty Cycle**
Determines the STPCLK# duty cycle when the THRM# pin is asserted. The duty cycle indicates the percentage of performance (the lower the percentage, the lower the performance and the higher the power savings). The STPCLK# duty cycle when THRM# is NOT asserted is controlled by PMIO Rx10[3:0]. If the setting in that field is lower than the setting in this field, the lower setting will be used.
0000 Reserved.....default
0001 0-6.25%
0010 6.25-12.50%
0011 18.75-25.00%
0100 31.25-37.50%
0101 37.50-43.75%
0110 43.75-50.00%
0111 50.00-56.25%
1000 56.25-62.50%
1001 62.50-68.75%
1010 68.75-75.00%
1011 75.00-87.50%
1100 75.00-81.25%
1101 81.25-87.50%
1110 87.50-93.75%
1111 93.75-100%
- 3 **THRM Input**
0 Disabledefault
1 Enable
- 2 **Reserved** always reads 0
- 1 **PCI Arbitration for C3 / POS**
0 Disabledefault
1 Enable
- 0 **CPU Stop Grant Cycle Select**
Controls whether halt can be used as stop grant cycle.
0 Halt is used as Stop Grant Cycle.....default
1 Halt is not used as Stop Grant Cycle

This bit is combined with PMIO Rx2C[3] for controlling the start of CPUSTP# assertion during system suspend mode:

PMIO Rx2C[3]	This Bit	CPUSTP# Assertion
0	x	Immediate
1	0	Wait for CPU Halt / Stop Grant cycle
1	1	Wait for CPU Stop Grant cycle

Offset 8D – Throttle / Clock Stop Control..... RW

- 7 **Throttle Timer Reset**..... def = 0
- 6-5 **Throttle Timer**
This field determines the number of bits used for the throttle timer, which in conjunction with the throttle timer tick determines the cycle time of STPCLK#. For example, if a 2-bit timer and a 7.5 usec timer tick are selected, the STPCLK# cycle time would be 30 usec (2**2 x 7.5). If a 4-bit timer and a 7.5 usec timer tick is selected, the cycle time would be 120 usec (2**4 x 7.5).
0x 4-Bit default
10 3-Bit
11 2-Bit
- 4 **Fast Clock (7.5us) as Throttle Timer Tick**
This bit controls whether the throttle timer tick uses 7.5 usec as its time base (120 usec cycle time when using a 4-bit timer).
0 Timer Tick is selected by Rx80[1] default
1 Timer Tick is 7.5 usec (Rx80[1] is ignored)
- 3 **SMI Level Output (Low)**
0 Disable..... default
1 Enable (during an SMI event, SMI# is held low until SMI event status is cleared)
- 2 **Internal Clock Stop for PCI Idle**
This bit controls whether the internal PCI clock is stopped when PCKRUN# is high.
0 PCI clock is not stopped..... default
1 PCI clock is stopped
- 1 **Internal Clock Stop During C3**
This bit controls whether the internal PCI clock is stopped during C3 state.
0 PCI clock is not stopped..... default
1 PCI clock is stopped
- 0 **Internal Clock Stop During Suspend**
This bit controls whether the internal PCI clock is stopped during Suspend state.
0 PCI clock is not stopped..... default
1 PCI clock is stopped

Offset 93-90 - GP Timer Control (0000 0000h)RW

- 31-30 Conserve Mode Timer Count Value**
 - 00 1/16 seconddefault
 - 01 1/8 second
 - 10 1 second
 - 11 1 minute

29 Conserve Mode Status
This bit reads 1 when in Conserve Mode

28 Conserve Mode
This bit controls whether conserve mode (throttling) is enabled. When this bit is set, the system can enter conserve mode when primary activity is not detected within a given time period (determined by bits 31-30 of this register). Primary activity is defined in PMIO Rx33-30.

- 0 Disabledefault
- 1 Enable

- 27-26 Secondary Event Timer Count Value**
 - 00 2 millisecondsdefault
 - 01 64 milliseconds
 - 10 1/2 second
 - 11 by EOI + 0.25 milliseconds

25 Secondary Event Occurred Status
This bit reads 1 to indicate that a secondary event has occurred (to resume the system from suspend) and the secondary event timer is counting down.

- 24 Secondary Event Timer Enable**
 - 0 Disabledefault
 - 1 Enable

23-16 GP1 Timer Count Value (base defined by bits 5-4)
Write to load count value; Read to get current count

15-8 GP0 Timer Count Value (base defined by bits 1-0)
Write to load count value; Read to get current count

7 GP1 Timer Start
On setting this bit to 1, the GP1 timer loads the value defined by bits 23-16 of this register and starts counting down. The GP1 timer is reloaded at the occurrence of certain peripheral events enabled in the GP Timer Reload Enable Register (Power Management I/O Space Offset 38h). If no such event occurs and the GP1 timer counts down to zero, then the GP1 Timer Timeout Status bit is set to one (bit-3 of the Global Status register at Power Management Register I/O Space Offset 28h). Additionally, if the GP1 Timer Timeout Enable bit is set (bit-3 of the Global Enable register at Power Management Register I/O Space Offset 2Ah), then an SMI is generated.

- 6 GP1 Timer Automatic Reload**
 - 0 GP1 Timer stops at 0default
 - 1 Reload GP1 timer automatically after counting down to 0

- 5-4 GP1 Timer Base**
 - 00 Disable..... default
 - 01 1/16 second
 - 10 1 second
 - 11 1 minute

3 GP0 Timer Start
On setting this bit to 1, the GP0 timer loads the value defined by bits 15-8 of this register and starts counting down. The GP0 timer is reloaded at the occurrence of certain peripheral events enabled in the GP Timer Reload Enable Register (Power Management I/O Space Offset 38h). If no such event occurs and the GP0 timer counts down to zero, then the GP0 Timer Timeout Status bit is set to one (bit-2 of the Global Status register at Power Management Register I/O Space Offset 28h). Additionally, if the GP0 Timer Timeout Enable bit is set (bit-2 of the Global Enable register at Power Management Register I/O Space Offset 2Ah), then an SMI is generated.

- 2 GP0 Timer Automatic Reload**
 - 0 GP0 Timer stops at 0 default
 - 1 Reload GP0 timer automatically after counting down to 0

- 1-0 GP0 Timer Base**
 - 00 Disable..... default
 - 01 1/16 second
 - 10 1 second
 - 11 1 minute

Offset 94 – Power Well Control..... WO

- 7 SMBus Clock Select**
 - 0 SMBus Clock from 14.31818 MHz Divider
 - 1 SMBus Clock from RTC 32.768 KHz ... default
- 6 STR Power Well Output Gating**
This bit controls whether the STR power well for internal signals is gated during STR.
 - 0 Disabledefault
 - 1 Enable
- 5 SUSC#Asserted in STR**
This bit controls whether SUSC# is asserted (low) during STR. Normally SUSC# is asserted during STD but not during STR.
 - 0 Disabledefault
 - 1 Enable
- 4 SUSST1# / GPO3 Select (Pin P1)**
 - 0 SUSST1#default
 - 1 GPO3
- 3 GPO2 / SUSB# Select (Pin W2)**
 - 0 SUSB#default
 - 1 GPO2

Before chip rev C, these definitions were reversed
- 2 GPO1 / SUSA# Select (Pin T2)**
 - 0 SUSA#default
 - 1 GPO1

Before chip rev C, these definitions were reversed
- 1-0 GPO0 Output Select (Pin P4)**
This field controls the GPO0 output signal for Pulse Width Modulation.
 - 00 GPO0 Fixed Output Level (defined by PMIO Rx4C[0])default
 - 01 GPO0 output is 1 Hz “SLOWCLK”
 - 10 GPO0 output is 4 Hz “SLOWCLK”
 - 11 GPO0 output is 16 Hz “SLOWCLK”

Offset 95 – Miscellaneous Power Well Control..... RW

- 7 CPUTP# to SUSST# Delay Select**
This bit controls the delay between the deassertion of CPUTP# and the deassertion of SUSST# during a resume.
 - 0 1 msec minimum default
 - 1 125 usec minimum
- 6 SUSST# Deasserted Before PWRGD for STD**
 - 0 Disable..... default
 - 1 Enable (SUST# is deasserted before PWRGD when resuming from STD)
- 5 Keyboard / Mouse Port Swap**
This bit determines whether the keyboard and mouse ports can be swapped.
 - 0 Disable..... default
 - 1 Enable
- 4 Reserved**always reads 0
- 3 SMB2 / GPO Select**
 - 0 SMBDT2 / SMBCK2 default
 - 1 GPO26 / GPO27
- 2 AOL 2 SMB Slave**
This bit controls whether external SMB masters can access internal SMB registers (for Alert-On-LAN).
 - 0 Enable (external SMB masters may reset / resume the system (when Rx96[4]=1) or detect GPI status)..... default
 - 1 Disable
- 1 SUSCLK / GPO4 Select**
 - 0 SUSCLK..... default
 - 1 GPO4
- 0 USB Wakeup for STR / STD / SoftOff**
This bit controls whether USB Wakeup is enabled when PMIO Rx21-20[14] (USB Wakeup Status) = 1. This allows wakeup from STR, STD, Soft Off, and POS.
 - 0 Disable..... default
 - 1 Enable

Offset 96 – Power On / Reset Control..... RW

- 7-4 Reserved**always reads 0
- 3-0 CPU Frequency Strapping Value Output to NMI, INTR, IGNNE#, and A20M# during RESET#**
The value written to this field is strapped through NMI, INTR, IGNNE#, and A20M# during RESET# to determine the multiplier for setting the CPU’s internal frequency. If the CPU hangs due to inappropriate settings written here, the GP3 timer (second timeout) can be used to initiate a system reboot (PMIO Rx42[2] = 1). Refer to the BIOS Porting Guide for additional details.

Offset 98 – GP2 / GP3 Timer ControlRW

7 GP3 Timer Start

On setting this bit to 1, the GP3 timer loads the value defined by Rx5A and starts counting down. The GP3 timer is reloaded at the occurrence of certain events enabled in the GP Timer Reload Enable Register (Power Management I/O Space Offset 38h). If no such event occurs and the GP3 timer counts down to zero, then the GP3 Timer Timeout Status bit is set to one (bit-13 of the Global Status register at Power Management Register I/O Space Offset 28h). Additionally, if the GP3 Timer Timeout Enable bit is set (bit-13 of the Global Enable register at Power Management Register I/O Space Offset 2Ah), then an SMI is generated.

6 GP3 Timer Automatic Reload

- 0 GP3 Timer stops at 0default
- 1 Reload GP3 timer automatically after counting down to 0

5-4 GP3 Timer Tick Select

- 00 Disabledefault
- 01 1/16 second
- 10 1 second
- 11 1 minute

3 GP2 Timer Start

On setting this bit to 1, the GP2 timer loads the value defined by Rx59 and starts counting down. The GP2 timer is reloaded at the occurrence of certain events enabled in the GP Timer Reload Enable Register (Power Management I/O Space Offset 38h). If no such event occurs and the GP2 timer counts down to zero, then the GP2 Timer Timeout Status bit is set to one (bit-12 of the Global Status register at Power Management Register I/O Space Offset 28h). Additionally, if the GP2 Timer Timeout Enable bit is set (bit-12 of the Global Enable register at Power Management Register I/O Space Offset 2Ah), then an SMI is generated.

2 GP2 Timer Automatic Reload

- 0 GP2 Timer stops at 0default
- 1 Reload GP2 timer automatically after counting down to 0

1-0 GP2 Timer Tick Select

- 00 Disabledefault
- 01 1/16 second
- 10 1 second
- 11 1 minute

Offset 99 – GP2 Timer RW

- 7 **Write: GP2 Timer Load Value** default = 0
- Read: GP2 Timer Current Count**

Offset 9A – GP3 Timer..... RW

- 7 **Write: GP3 Timer Load Value** default = 0
- Read: GP3 Timer Current Count**

Offset C3-C0 – Power Management Capability..... RO

- 31-16 Power Management Capability**.always reads 0002h
- 15-8 Next Pointer**always reads 00h
- 7-0 Capability ID**always reads 01h

Offset C7-C4 – Power Mgmt Capability CSR RW

- 31-24 Power Management Data**always reads 00h
- 23-16 PM CSR P2P Support Extensions** always reads 00h
- 15-0 PM Control / Status (D0/D3 Only)**.. default = 0000h

System Management Bus-Specific Configuration Registers

Offset D1-D0 – SMBus I/O Base.....RW

- 15-4 I/O Base (16-byte I/O space) default = 00h
- 3-0 Fixed always reads 0001b

Offset D2 – SMBus Host Configuration.....RW

- 7-4 Reserved always reads 0
- 3 **SMBus Interrupt Select**
 - 0 SMIdefault
 - 1 SCI
- 2 **SMBus Clock From 64K Source (Divider from 14.31818 MHz)**
 - 0 Disabledefault
 - 1 Enable
- 1 **SMBus IRQ**
 - 0 Disabledefault
 - 1 Enable
- 0 **SMBus Host Controller Enable**
 - 0 Disable SMB controller functions.....default
 - 1 Enable SMB controller functions

Offset D3 – SMBus Host Slave Command RW

- 7-0 SMBus Host Slave Command Code..... default=0

Offset D4 – SMBus Slave Address for Port 1..... RW

- 7-1 SMBus Slave Address for Port 1..... default=0
- 0 Read / Write for Shadow Port 1

Offset D5 – SMBus Slave Address for Port 2..... RW

- 7-1 SMBus Slave Address for Port 2..... default=0
- 0 Read / Write for Shadow Port 2

Offset D6 – SMBus Revision ID RO

- 7-0 SMBus Revision Code

General Purpose I/O Control Registers

Offset E0 – GPI Inversion Control.....RW

- 7-0 **GPI[27-24, 19-16] Input Inversion**
 - 0 Non-inverted inputdefault
 - 1 Inverted input

Offset E1 – GPI SCI / SMI Select.....RW

- 7-0 **GPI[27-24, 19-16] SCI / SMI Select**
When GPI[27-24,19-16] are set to enable SCI / SMI generation (PMIO Rx52), this field determines whether an SCI or SMI is generated.
 - 0 SCIdefault
 - 1 SMI

Offset E4 – GPO Pin Select.....RW

- 7 **GPO22-23 / IOR#, IOW# Select (Pins R9, T7)**
 - 0 R9 = GPO22, T7 = GPO23default
 - 1 R9 = IOR#, T7 = IOW#
- 6 **ACSDIN2,3 / GPIO20,21 Select (Pins M1, L3)**
This bit is ignored if any of RxE5 bits 1, 2, 4, or 5 = 1
 - 0 M1 = ACSDIN2, L3 = ACSDIN3default
 - 1 M1 = GPIO20, L3 = GPIO21
- 5 **SA[19:16] / GPO[19:16] Select (R10, U8, Y9, W9)**
 - 0 SA[19:16].....default
 - 1 GPO[19:16]
- 4 **GPIO[15:12] Direction**
 - 0 Input (pins are GPI[15:12]).....default
 - 1 Output (pins are GPO[15:12])
- 3 **GPIO[11:8] Direction**
 - 0 Input (pins are GPI[11:8]).....default
 - 1 Output (pins are GPO[11:8])
- 2 **SLP# / GPO7 Select (Pin K19)**
 - 0 K19 = SLP#default
 - 1 K19 = GPO7
- 1 **PCISTP# / GPO6 Select (Pin V6)**
 - 0 V6 = PCISTP#default
 - 1 V6 = GPO6
- 0 **CPUSTP# / GPO5 Select (Pin Y5)**
 - 0 Y5 = CPUSTP#default
 - 1 Y5 = GPO5

Offset E5 – GPIO I/O Select 1.....RW

- 7 **Reserved**always reads 0
- 6 **AGPBZ# as Source of Bus Master Status (PMIO Rx0[4])**
 - 0 Disable..... default
 - 1 Enable
- 5 **AGPBZ# on ACSDIN3 (Pin L3)**
 - 0 L3 = ACSDIN3 / GPIO21 / PCS1# default
 - 1 L3 = AGPBZ# (bit 2 and RxE4[6] are ignored)
- 4 **VGATE on ACSDIN2 (Pin M1)**
 - 0 M1 = ACSDIN2 / GPIO20 / PCS0# default
 - 1 M1 = VGATE (bit 1 and RxE4[6] are ignored)
- 3 **Intel Speedstep Function**
 - 0 Enable (Pin U6 = VIDSEL, W5 = GHI#, C8 = VRDPSLP) default
 - 1 Disable (Pin U6 = GPIO31 / GPIOE, W5 = GPIO30 / GPIOD, C8 = GPIO9)
- 2 **PCS1# on ACSDIN3 (Pin L3)**
 - 0 L3 = ACSDIN3 / GPIO21 / AGPBZ / SLPBTN# default
 - 1 L3 = PCS1# (RxE4[6] ignored)
- 1 **PCS0# on ACSDIN2 (Pin M1)**
 - 0 M1 = ACSDIN2 / GPIO20 / VGATE ... default
 - 1 M1 = PCS0# (RxE4[6] ignored)
- 0 **IORDY / GPI19 Select (Pin R8)**
 - 0 R8 = IORDY default
 - 1 R8 = GPI19

Offset E6 – GPIO I/O Select 2.....RW

- 7 **GPI31 / GPO31 (GPIOE) Select (Pin U6)**
 - 0 U6 = GPI31 default
 - 1 U6 = GPO31 / GPIOE
- 6 **GPI30 / GPO30 (GPIOD) Select (Pin W5)**
 - 0 W5 = GPI30 default
 - 1 W5 = GPO30 / GPIOD
- 5-2 **Reserved**always reads 0
- 1 **GPI25 / GPO25 (GPIOC) Select (Pin T6)**
 - 0 T6 = GPI25 default
 - 1 T6 = GPO25 / GPIOC
- 0 **GPI24 / GPO24 (GPIOA) Select (Pin V4)**
 - 0 V4 = GPI24 default
 - 1 V4 = GPO24 / GPIOA

Offset E7 – GPO Output Type.....RW

These bits determine whether the indicated GPO pin is open drain or TTL when the corresponding bit of RxE6 = 1.

- 7 **GPO31 OD/TTL Select (Pin U6)**
- 6 **GPO30 OD/TTL Select (Pin W5)**
- 5-2 **Reserved**always reads 0
- 1 **GPO25 OD/TTL Select (Pin T6)**
- 0 **GPO24 OD/TTL Select (Pin V4)**

For all defined bits above:

- 0 OD default
- 1 TTL

Power Management I/O-Space Registers

Basic Power Management Control and Status

I/O Offset 1-0 - Power Management Status.....RWC

The bits in this register are set only by hardware and can be reset by software by writing a one to the desired bit position.

- 15 Wakeup Status** default = 0
This bit is set when the system is in the suspend state and an enabled resume event occurs. Upon setting this bit, the system automatically transitions from the suspend state to the normal working state (from C3 to C0 for the processor).
- 14-12 Reserved** always reads 0
- 11 Abnormal Power-Off Status** default = 0
- 10 RTC Alarm Status** default = 0
This bit is set when the RTC generates an alarm (on assertion of the RTC IRQ signal).
- 9 Sleep Button Status**..... default = 0
This bit is set when the sleep button (SLPBTN# / IRQ6 / GPI4) is pressed.
- 8 Power Button Status** default = 0
This bit is set when the PWRBTN# signal is asserted low. If the PWRBTN# signal is held low for more than four seconds, this bit is cleared, the PBOR_STS bit is set, and the system will transition into the soft off state.
- 7-6 Reserved** always reads 0
- 5 Global Status**..... default = 0
This bit is set by hardware when the BIOS Release bit is set (typically by an SMI routine to release control of the SCI / SMI lock). When this bit is cleared by software (by writing a one to this bit position) the BIOS Release bit is also cleared at the same time by hardware.
- 4 Bus Master Status**..... default = 0
This bit is set when a system bus master requests the system bus. All PCI master, ISA master and ISA DMA devices are included. See also Function 0 RxE5[6] (“AGPBZ# as Source of Bus Master Status”).
- 3-1 Reserved** always reads 0
- 0 ACPI Timer Carry Status**..... default = 0
The bit is set when the 23rd (31st) bit of the 24 (32) bit ACPI power management timer changes.

I/O Offset 3-2 - Power Management Enable RW

The bits in this register correspond to the bits in the Power Management Status Register at offset 1-0.

- 15 Reserved**always reads 0
- 14-12 Reserved** always reads 0
- 11 Reserved**always reads 0
- 10 RTC Alarm Enable** default = 0
This bit may be set to trigger either an SCI or an SMI (depending on the setting of the SCI Enable bit) to be generated when the RTC Status bit is set.
- 9 Sleep Button Enable**..... default = 0
This bit may be set to trigger either an SCI or SMI when the Sleep Button Status bit is set.
- 8 Power Button Enable** default = 0
This bit may be set to trigger either an SCI or an SMI (depending on the setting of the SCI Enable bit) to be generated when the Power Button Status bit is set.
- 7-6 Reserved**always reads 0
- 5 Global Enable** default = 0
This bit may be set to trigger either an SCI or an SMI (depending on the setting of the SCI Enable bit) to be generated when the Global Status bit is set.
- 4 Reserved**always reads 0
- 3-1 Reserved**always reads 0
- 0 ACPI Timer Enable** default = 0
This bit may be set to trigger either an SCI or an SMI (depending on the setting of the SCI Enable bit) to be generated when the Timer Status bit is set.

I/O Offset 5-4 - Power Management ControlRW

- 15 Soft Resume**
This bit is used to allow a system using an AT power supply to operate as if an ATX power supply were being used. Refer to the BIOS Porting Guide for implementation details.
0 Disabledefault
1 Enable
- 14 Reserved** always reads 0
- 13 Sleep Enable** always reads 0
This is a write-only bit; reads from this bit always return zero. Writing a one to this bit causes the system to sequence into the sleep (suspend) state defined by the Sleep Type field.
- 12-10 Sleep Type**
000 Normal On
001 Suspend to RAM (STR)
010 Suspend to Disk (STD) (also called Soft Off).
The VCC power plane is turned off while the VCCS and VBAT planes remain on.
011 Reserved
100 Power On Suspend without Reset
101 Power On Suspend with CPU Reset
110 Power On Suspend with CPU/PCI Reset
111 Reserved
In any sleep state, there is minimal interface between powered and non-powered planes so that the effort for hardware design may be well managed.
- 9 Reserved** always reads 0
- 8 STD Command Generates System Reset Only**
0 Disabledefault
1 Enable (STD command generates a system reset and not STD)
- 7-3 Reserved** always reads 0
- 2 Global Release** **WO**, default = 0
This bit is set by ACPI software to indicate the release of the SCI / SMI lock. Upon setting of this bit, the hardware automatically sets the BIOS Status bit. The bit is cleared by hardware when the BIOS Status bit is cleared by software. Note that the setting of this bit will cause an SMI to be generated if the BIOS Enable bit is set (bit-5 of the Global Enable register at offset 2Ah).
- 1 Bus Master Reload**
This bit controls whether bus master requests (PMIO Rx00[4] = 1) transition the processor from C3 to C0 state.
0 Bus master requests are ignored by power management logicdefault
1 Bus master requests transition the processor from the C3 state to the C0 state

- 0 SCI Enable**
This bit controls whether SCI or SMI is generated for power management events triggered by the Power Button, Sleep Button, and RTC (when PMIO Rx1-0 bits 8, 9, or 10 equal one).
0 Generate SMI default
1 Generate SCI
Note that certain power management events can be programmed individually to generate an SCI or SMI independent of the setting of this bit (refer to the General Purpose SCI Enable and General Purpose SMI Enable registers at offsets 22 and 24). Also, Timer Status & Global Status always generate SCI and BIOS Status always generates SMI.

I/O Offset 0B-08 - Power Management Timer RW

- 31-24 Extended Timer Value**
This field reads back 0 if the 24-bit timer option is selected (Rx41 bit-3).
- 23-0 Timer Value**
This read-only field returns the running count of the power management timer. This is a 24/32-bit counter that runs off a 3.579545 MHz clock, and counts while in the S0 (working) system state. The timer is reset to an initial value of zero during a reset, and then continues counting until the 14.31818 MHz input to the chip is stopped. If the clock is restarted without a reset, then the counter will continue counting from where it stopped.

Processor Power Management Registers

I/O Offset 13-10 - Processor & PCI Bus ControlRW

- 31-12 **Reserved** always reads 0
- 11 **PCISTP# Asserted when PCKRUN# is Deasserted**
 - 0 Enabledefault
 - 1 Disable
- 10 **PCI Bus Clock Run Without Stop**
 - 0 PCKRUN# is always asserted.....default
 - 1 PCKRUN# will be de-activated after the PCI bus is idle for 26 clocks
- 9 **Host Clock Stop**
This bit controls whether CPUSTP# is asserted in C3 and S1 states. Normally CPUSTP# is not asserted in C3 and S1 states, only STPCLK# is asserted.
 - 0 CPUSTP# will not be asserted in C3 and S1 states (only STPCLK# is asserted).....default
 - 1 CPUSTP# will be asserted in C3 and S1 states
- 8 **Assert SLP# for Processor Level 3 Read**
This bit controls whether SLP# is asserted in C3 state.
 - 0 SLP# is not asserted in C3 statedefault
 - 1 SLP# is asserted in C3 state
 Used with Intel CPUs only.
- 1 **Lower CPU Voltage During C3 / S1**
This bit controls whether the CPU voltage is lowered when in C3/S1 state. The voltage is lowered using the VRDSLP signal to the voltage regulator (PMIO RxE5[3] must be 0 to enable the voltage change function).
 - 0 Disable (normal voltage during C3/S1)def
 - 1 Enable (lower voltage during C3/S1)
- 6-5 **Reserved** always reads 0

- 4 **Throttling Enable**
Setting this bit starts clock throttling (modulating the STPCLK# signal) regardless of the CPU state. The throttling duty cycle is determined by bits 3-0 of this register.
- 3-0 **Throttling Duty Cycle**
This field determines the duty cycle of the STPCLK# signal when the system is in throttling mode ("Throttling Enable" bit set to one). The duty cycle indicates the percentage of performance (the lower the percentage, the lower the performance and the higher the power savings).
 - 0000 Reserved
 - 0001 0-6.25%
 - 0010 6.25-12.50%
 - 0011 18.75-25.00%
 - 0100 31.25-37.50%
 - 0101 37.50-43.75%
 - 0110 43.75-50.00%
 - 0111 50.00-56.25%
 - 1000 56.25-62.50%
 - 1001 62.50-68.75%
 - 1010 68.75-75.00%
 - 1011 75.00-87.50%
 - 1100 75.00-81.25%
 - 1101 81.25-87.50%
 - 1110 87.50-93.75%
 - 1111 93.75-100%

I/O Offset 14 - Processor Level 2..... RO

- 7-0 **Level 2**always reads 0
Reads from this register put the processor into the Stop Grant state (the VT8233 asserts STPCLK# to suspend the processor). Wake up from Stop Grant state is by interrupt (INTR, SMI, and SCI).

Reads from this register return all zeros; writes have no effect.

I/O Offset 15 - Processor Level 3..... RO

- 7-0 **Level 3**always reads 0
Reads from this register put the processor in the C3 clock state with the STPCLK# signal asserted. If Rx10[9] = 1 then the CPU clock is also stopped by asserting CPUSTP#. Wakeup from the C3 state is by interrupt (INTR, SMI, and SCI).

Reads from this register return all zeros; writes have no effect.

General Purpose Power Management Registers

I/O Offset 21-20 - General Purpose Status..... RWC

- 15 **North Bridge SERR# Status**
- 14 **USB Wake-Up Status**
For STR / STD / Soff
- 13 **AC97 Wake-Up Status**
Can be set only in suspend mode
- 12 **Battery Low Status**
Set when the BATLOW# input is asserted low.
- 11 **Notebook Lid Status**
Set when the LID input detects the edge selected by Rx2C bit-7 (0=rising, 1=falling).
- 10 **Thermal Detect Status**
Set when the THRM# input detects the edge selected by Rx2C bit-6 (0=rising, 1=falling).
- 9 **USB Resume Status**
Set when a USB peripheral generates a resume event.
- 8 **Ring Status**
Set when the RING# input is asserted low.
- 7 **Reserved** always reads 0
- 6 **INTRUDER# Status**
Set when the INTRUDER# pin is asserted low.
- 5 **PME# Status**
Set when the PME# pin is asserted low.
- 4 **EXTSMI# Status**
Set when the EXTSMI# pin is asserted low.
- 3 **Internal LAN PME Status**
Set when the internal LAN PME signal is asserted.
- 2 **Internal KBC PME Status**
Set when the internal KBC PME signal is asserted.
- 1 **GPI1 Status**
Set when the GPI1 pin is asserted low.
- 0 **GPI0 Status**
Set when the GPI0 pin is asserted low.

Note that the above bits correspond one for one with the bits of the General Purpose SCI Enable and General Purpose SMI Enable registers at offsets 22 and 24: an SCI or SMI is generated if the corresponding bit of the General Purpose SCI or SMI Enable registers, respectively, is set to one.

The above bits are set by hardware only and can only be cleared by writing a one to the desired bit.

I/O Offset 23-22 - General Purpose SCI Enable RW

- 15 **Enable SCI on setting of Rx21-20[15]..... def=0**
- 14 **Enable SCI on setting of Rx21-20[14]..... def=0**
- 13 **Enable SCI on setting of Rx21-20[13]..... def=0**
- 12 **Enable SCI on setting of Rx21-20[12]..... def=0**
- 11 **Enable SCI on setting of Rx21-20[11]..... def=0**
- 10 **Enable SCI on setting of Rx21-20[10]..... def=0**
- 9 **Enable SCI on setting of Rx21-20[9]..... def=0**
- 8 **Enable SCI on setting of Rx21-20[8]..... def=0**
- 7 **Reserved** always reads 0
- 6 **Enable SCI on setting of Rx21-20[6]..... def=0**
- 5 **Enable SCI on setting of Rx21-20[5]..... def=0**
- 4 **Enable SCI on setting of Rx21-20[4]..... def=0**
- 3 **Enable SCI on setting of Rx21-20[3]..... def=0**
- 2 **Enable SCI on setting of Rx21-20[2]..... def=0**
- 1 **Enable SCI on setting of Rx21-20[1]..... def=0**
- 0 **Enable SCI on setting of Rx21-20[0]..... def=0**

These bits allow generation of an SCI using a separate set of conditions from those used for generating an SMI.

I/O Offset 25-24 - General Purpose SMI Enable RW

- 15 **Enable SMI on setting of Rx21-20[15]..... def=0**
- 14 **Enable SMI on setting of Rx21-20[14]..... def=0**
- 13 **Enable SMI on setting of Rx21-20[13]..... def=0**
- 12 **Enable SMI on setting of Rx21-20[12]..... def=0**
- 11 **Enable SMI on setting of Rx21-20[11]..... def=0**
- 10 **Enable SMI on setting of Rx21-20[10]..... def=0**
- 9 **Enable SMI on setting of Rx21-20[9]..... def=0**
- 8 **Enable SMI on setting of Rx21-20[8]..... def=0**
- 7 **Reserved** always reads 0
- 6 **Enable SMI on setting of Rx21-20[6]..... def=0**
- 5 **Enable SMI on setting of Rx21-20[5]..... def=0**
- 4 **Enable SMI on setting of Rx21-20[4]..... def=0**
- 3 **Enable SMI on setting of Rx21-20[3]..... def=0**
- 2 **Enable SMI on setting of Rx21-20[2]..... def=0**
- 1 **Enable SMI on setting of Rx21-20[1]..... def=0**
- 0 **Enable SMI on setting of Rx21-20[0]..... def=0**

These bits allow generation of an SMI using a separate set of conditions from those used for generating an SCI.

Generic Power Management Registers

I/O Offset 29-28 - Global Status..... RWC

- 15 **GPIO Range 1 Access Status** default = 0
- 14 **GPIO Range 0 Access Status** default = 0
- 13 **GP3 Timer Timeout Status** default = 0
- 12 **GP2 Timer Timeout Status** default = 0
- 11 **SERIRQ SMI Status**..... default = 0
- 10 **Rx5[5] Write SMI Status**..... default = 0
This bit reports whether Rx5[5] is written. If Rx2B[3] is set to enable SMI, an SMI is generated when this bit = 1.
- 9 **Reserved** always reads 0
- 8 **PCKRUN# Resume Status** default = 0
This bit is set when PCI bus peripherals wake up the system by asserting PCKRUN#
- 7 **Primary IRQ/INIT/NMI/SMI Resume Status**def=0
This bit is set at the occurrence of primary IRQs as defined in Rx85-84 of PCI configuration space
- 6 **Software SMI Status**..... default = 0
This bit is set when the SMI Command port (Rx2F) is written.
- 5 **BIOS Status** default = 0
This bit is set when the Global Release bit is set to one (typically by the ACPI software to release control of the SCI/SMI lock). When this bit is reset (by writing a one to this bit position) the Global Release bit is reset at the same time by hardware.
- 4 **Legacy USB Status**..... default = 0
This bit is set when a legacy USB event occurs. This is normally used for USB keyboards.
- 3 **GP1 Timer Time Out Status** default = 0
This bit is set when the GP1 timer times out.
- 2 **GP0 Timer Time Out Status** default = 0
This bit is set when the GP0 timer times out.
- 1 **Secondary Event Timer Time Out Status**..... def=0
This bit is set when the secondary event timer times out.
- 0 **Primary Activity Status**..... default = 0
This bit is set at the occurrence of any enabled primary system activity (see the Primary Activity Detect Status register at offset 30h and the Primary Activity Detect Enable register at offset 34h). After checking this bit, software can check the status bits in the Primary Activity Detect Status register at offset 30h to identify the specific source of the primary event. Note that setting this bit can be enabled to reload the GP0 timer (see bit-0 of the GP Timer Reload Enable register at offset 38).

Note that SMI can be generated based on the setting of any of the above bits (see the Rx2A Global Enable register bit descriptions in the right hand column of this page).

The bits in this register are set by hardware only and can only be cleared by writing a one to the desired bit position.

The bits in this register are for SMI's only while the bits in Rx21-20 are for SMI's and SCI's

I/O Offset 2B-2A - Global Enable RW

- 15 **GPIO Range 1 SMI Enable** default = 0
- 14 **GPIO Range 0 SMI Enable** default = 0
- 13 **GP3 Timer Timeout SMI Enable**..... default = 0
- 12 **GP2 Timer Timeout SMI Enable**..... default = 0
- 11 **SERIRQ SMI Enable**..... default = 0
- 10 **SMI on Sleep Enable Write** default = 0
- 9 **Reserved** always reads 0
- 8 **PCKRUN# Resume Enable** default = 0
This bit may be set to trigger an SMI to be generated when the PCKRUN# Resume Status bit is set.
- 7 **Primary IRQ/INIT/NMI/SMI Resume Enable In Post State** default = 0
This bit may be set to trigger an SMI to be generated when the Primary IRQ / INIT / NMI / SMI Resume Status bit is set.
- 6 **SMI on Software SMI** default = 0
This bit may be set to trigger an SMI to be generated when the Software SMI Status bit is set.
- 5 **SMI on BIOS Status**..... default = 0
This bit may be set to trigger an SMI to be generated when the BIOS Status bit is set.
- 4 **SMI on Legacy USB** default = 0
This bit may be set to trigger an SMI to be generated when the Legacy USB Status bit is set.
- 3 **SMI on GP1 Timer Time Out** default = 0
This bit may be set to trigger an SMI to be generated when the GP1 Timer Timeout Status bit is set.
- 2 **SMI on GP0 Timer Time Out** default = 0
This bit may be set to trigger an SMI to be generated when the GP0 Timer Timeout Status bit is set.
- 1 **SMI on Secondary Event Timer Time Out** def=0
This bit may be set to trigger an SMI to be generated when the Secondary Event Timer Timeout Status bit is set.
- 0 **SMI on Primary Activity** default = 0
This bit may be set to trigger an SMI to be generated when the Primary Activity Status bit is set.

I/O Offset 2D-2C - Global ControlRW

- 15-12 Reserved** always reads 0
- 11 IDE Secondary Bus Power-Off**
 - 0 Disabledefault
 - 1 Enable
- 10 IDE Primary Bus Power-Off**
 - 0 Disabledefault
 - 1 Enable
- 9 Reserved** always reads 0
- 8 SMI Active**
 - 0 SMI Inactivedefault
 - 1 SMI Active. If the SMI Lock bit is set, this bit needs to be written with a 1 to clear it before the next SMI can be generated.
- 7 LID Triggering Polarity**
 - 0 Rising Edge.....default
 - 1 Falling Edge
- 6 THRM# Triggering Polarity**
 - 0 Rising Edge.....default
 - 1 Falling Edge
- 5 Battery Low Resume Disable**
 - 0 Enable resume.....default
 - 1 Disable resume from suspend when BATLOW# is asserted
- 4 SMI Lock**
 - 0 Disable SMI Lock
 - 1 Enable SMI Lock (SMI low to gate for the next SMI).....default
- 3 Wait for Halt / Stop Grant Cycle for CPUSTP# Assertion**
 - 0 Don't waitdefault
 - 1 Wait

This bit works with Rx8C[0] of PCI configuration space to control the start of CPUSTP# assertion.
- 2 Power Button Triggering Select**
 - 0 SCI/SMI generated by PWRBTN# rising edgedefault
 - 1 SCI/SMI generated by PWRBTN# low level

Set to zero to avoid the situation where the Power Button Status bit is set to wake up the system then reset again by PBOR Status to switch the system into the soft-off state.
- 1 BIOS Release**

This bit is set by legacy software to indicate release of the SCI/SMI lock. Upon setting of this bit, hardware automatically sets the Global Status bit. This bit is cleared by hardware when the Global Status bit cleared by software.

Note that if the Global Enable bit is set (Power Management Enable register Rx2[5]), then setting this bit causes an SCI to be generated (because setting this bit causes the Global Status bit to be set).
- 0 SMI Enable**
 - 0 Disable all SMI generationdefault
 - 1 Enable SMI generation

I/O Offset 2F - SMI Command..... RW

- 7-0 SMI Command**

Writing to this port sets the Software SMI Status bit. Note that if the Software SMI Enable bit is set (see Global Enable register Rx2A[6]), then an SMI is generated.

I/O Offset 33-30 - Primary Activity Detect Status..... RWC

These bits correspond to the Primary Activity Detect Enable bits in Rx37-34. If the corresponding bit is set in that register, setting of a bit below will cause the Primary Activity Status (PACT_STS) bit to be set (Global Status register Rx28[0]). All bits in this register default to 0, are set by hardware only, and may only be cleared by writing 1s to the desired bit.

- 31-11 Reserved**always read 0
- 10 Audio Access Status..... (AUD_STS)**
Set if Audio is accessed.
- 9 Keyboard Controller Access Status (KBC_STS)**
Set if the KBC is accessed via I/O port 60h.
- 8 VGA Access Status (VGA_STS)**
Set if the VGA port is accessed via I/O ports 3B0-3DFh or memory space A0000-BFFFFh.
- 7 Parallel Port Access Status..... (LPT_STS)**
Set if the parallel port is accessed via I/O ports 278-27Fh or 378-37Fh (LPT2 or LPT1).
- 6 Serial Port B Access Status(COMB_STS)**
Set if the serial port is accessed via I/O ports 2F8-2FFh or 2E8-2Efh (COM2 and COM4 respectively).
- 5 Serial Port A Access Status..... (COMA_STS)**
Set if the serial port is accessed via I/O ports 3F8-3FFh or 3E8-3EFh (COM1 and COM3, respectively).
- 4 Floppy Access Status(FDC_STS)**
Set if the floppy controller is accessed via I/O ports 3F0-3F5h or 3F7h.
- 3 Secondary IDE Access Status(SIDE_STS)**
Set if the IDE controller is accessed via I/O ports 170-177h or 376h.
- 2 Primary IDE Access Status..... (PIDE_STS)**
Set if the IDE controller is accessed via I/O ports 1F0-1F7h or 3F6h.
- 1 Primary Interrupt Activity Status.....(PIRQ_STS)**
Set on the occurrence of a primary interrupt (enabled via the "Primary Interrupt Channel" register at Function 4 PCI configuration register offset 44h).
- 0 PCI Master Access Status (DRQ_STS)**
Set on the occurrence of PCI master activity.

I/O Offset 37-34 - Primary Activity Detect Enable..... RW

These bits correspond to the Primary Activity Detect Status bits in Rx33-30. Setting of any of these bits also sets the Primary Activity Status (PACT_STS) bit (Rx28[0]) which causes the GP0 timer to be reloaded (if the Primary Activity GP0 Enable bit is set) or generates an SMI (if Primary Activity Enable is set).

- 31-11 Reserved** always read 0
- 10 SMI on Audio Status..... (AUD_EN)**
0 Don't set PACT_STS if AUD_STS is set.... def
1 Set PACT_STS if AUD_STS is set
- 9 SMI on Keyboard Controller Status (KBC_EN)**
0 Don't set PACT_STS if KBC_STS is set def
1 Set PACT_STS if KBC_STS is set
- 8 SMI on VGA Status (VGA_EN)**
0 Don't set PACT_STS if VGA_STS is set.... def
1 Set PACT_STS if VGA_STS is set
- 7 SMI on Parallel Port Status..... (LPT_EN)**
0 Don't set PACT_STS if LPT_STS is set def
1 Set PACT_STS if LPT_STS is set
- 6 SMI on Serial Port B Status(COMB_EN)**
0 Don't set PACT_STS if COMB_STS is set. def
1 Set PACT_STS if COMB_STS is set
- 5 SMI on Serial Port A Status..... (COMA_EN)**
0 Don't set PACT_STS if COMA_STS is set. def
1 Set PACT_STS if COMA_STS is set
- 4 SMI on Floppy Status(FDC_EN)**
0 Don't set PACT_STS if FDC_STS is set..... def
1 Set PACT_STS if FDC_STS is set
- 3 SMI on Secondary IDE Status(SIDE_EN)**
0 Don't set PACT_STS if SIDE_STS is set.... def
1 Set PACT_STS if SIDE_STS is set
- 2 SMI on Primary IDE Status.....(PIDE_EN)**
0 Don't set PACT_STS if PIDE_STS is set.... def
1 Set PACT_STS if PIDE_STS is set
- 1 SMI on Primary IRQ Status (PIRQ_EN)**
0 Don't set PACT_STS if PIRQ_STS is set ... def
1 Set PACT_STS if PIRQ_STS is set
- 0 SMI on PCI Master Status (DRQ_EN)**
0 Don't set PACT_STS if DRQ_STS is set.... def
1 Set PACT_STS if DRQ_STS is set

Note: Setting of Primary Activity Status (PACT_STS) may be done to enable a "Primary Activity Event": an SMI will be generated if the Primary Activity Enable bit is set (Global Enable register Rx2A[0]) and/or the GP0 timer will be reloaded if the "GP0 Timer Reload on Primary Activity" bit is set (GP Timer Reload Enable register Rx38[0]).

Note: Bits 2-9 above also correspond to bits of GP Timer Reload Enable register Rx38: If bits are set in that register, setting a corresponding bit in this register will cause the GP1 timer to be reloaded.

I/O Offset 3B-38 - GP Timer Reload EnableRW

All bits in this register default to 0 on power up.

- 31-8 Reserved** always reads 0
- 7 GP1 Timer Reload on KBC Access**
 - 0 Normal GP1 Timer Operation.....default
 - 1 Setting of KBC_STS causes the GP1 timer to reload.
- 6 GP1 Timer Reload on Serial Port Access**
 - 0 Normal GP1 Timer Operationdefault
 - 1 Setting of COMA_STS or COMB_STS causes the GP1 timer to reload.
- 5 Reserved** always reads 0
- 4 GP1 Timer Reload on VGA Access**
 - 0 Normal GP1 Timer Operationdefault
 - 1 Setting of VGA_STS causes the GP1 timer to reload.
- 3 GP1 Timer Reload on IDE/Floppy Access**
 - 0 Normal GP1 Timer Operationdefault
 - 1 Setting of FDC_STS, SIDE_STS, or PIDE_STS causes the GP1 timer to reload.
- 2 GP3 Timer Reload on GPIO Range 1 Access**
 - 0 Normal GP3 Timer Operationdefault
 - 1 Setting of GR1_STS causes the GP3 timer to reload.
- 1 GP2 Timer Reload on GPIO Range 0 Access**
 - 0 Normal GP2 Timer Operationdefault
 - 1 Setting of GR0_STS causes the GP2 timer to reload.
- 0 GP0 Timer Reload on Primary Activity**
 - 0 Normal GP0 Timer Operationdefault
 - 1 Setting of PACT_STS causes the GP0 timer to reload. Primary activities are enabled via the Primary Activity Detect Enable register (offset 37-34) with status recorded in the Primary Activity Detect Status register (offset 33-30).

I/O Offset 40 – Extended I/O Trap Status.....RWC

- 7-5 Reserved**always reads 0
- 4 BIOS Write Access Status**
- 3 GP3 Timer Second Timeout With No Cycles**
 - 0 Disable..... default
 - 1 Enable (GP3 timer timed out twice with no cycles in between)
- 2 GP3 Timer Second Timeout Status**
- 1 GPIO Range 3 Access Status**
- 0 GPIO Range 2 Access Status**

I/O Offset 42 – Extended I/O Trap Enable RW

- 7-5 Reserved**always reads 0
- 4 SMI on BIOS Write Access**
This bit controls whether SMI is generated when BIOS Write Access Status Rx40[4] = 1.
 - 0 Disable..... default
 - 1 Enable (can be reset only by OCI_Reset)
- 3 Reserved**always reads 0
- 2 GP3 Timer Second Timeout Reboot**
This bit controls whether the system is rebooted when the GP3 timer times out twice (Rx40[2] = 1).
 - 0 Disable..... default
 - 1 Enable
- 1 SMI on GPIO Range 3 Access**
This bit controls whether SMI is generated when GPIO range 3 is accessed (Rx40[1] = 1)
 - 0 Disable..... default
 - 1 Enable
- 0 SMI on GPIO Range 2 Access**
This bit controls whether SMI is generated when GPIO range 2 is accessed (Rx40[0] = 1)
 - 0 Disable..... default
 - 1 Enable

General Purpose I/O Registers

I/O Offset 45 – SMI / IRQ / Resume StatusRO

- 7-5 **Reserved** always reads 0
- 4 **Latest PCSn Status**
 - 0 Latest PCSn was an I/O Read
 - 1 Latest PCSn was an I/O Write
- 3 **Serial SMI Status**
This bit is used to report a Serial-IRQ-generated SMI.
- 2 **Reserved** always reads 0
- 1 **SMBus IRQ Status**
This bit is used to report an SMBus SMI.
- 0 **SMBus Resume Status**
This bit is used to report an SMBus Resume Event.

I/O Offset 4B-48 - GPI Port Input Value (GPIVAL).....RO

- 31-0 **GPI[31-0] Input Value**.....Read Only

I/O Offset 4F-4C - GPO Port Output Value (GPOVAL)RW

Reads from this register return the last value written (held on chip). Some GPIO pins can be used as both input and output (GPIO pins 8-15 and 20-31). The output type of these pins is OD (open drain) so to use one of these pins as an input pin, a one must be written to the corresponding bit of this register. See also Function 0 RxE4[4-3] for I/O control of GPIO pins 8-15.

- 31-0 **GPO[31-0] Output Value**def = FFFFFFFFh

I/O Offset 50 – GPI Pin Change StatusRW

- 7 **GPI27 Pin Change Status**..... default = 0
- 6 **GPI26 Pin Change Status**..... default = 0
- 5 **GPI25 Pin Change Status**..... default = 0
- 4 **GPI24 Pin Change Status**..... default = 0
- 3 **GPI19 Pin Change Status**..... default = 0
- 2 **GPI18 Pin Change Status**..... default = 0
- 1 **GPI17 Pin Change Status**..... default = 0
- 0 **GPI16 Pin Change Status**..... default = 0

I/O Offset 52 – GPI Pin Change SCI/SMI SelectRW

- 7 **GPI27 Pin SCI / SMI Select**
- 6 **GPI26 Pin SCI / SMI Select**
- 5 **GPI25 Pin SCI / SMI Select**
- 4 **GPI24 Pin SCI / SMI Select**
- 3 **GPI19 Pin SCI / SMI Select**
- 2 **GPI18 Pin SCI / SMI Select**
- 1 **GPI17 Pin SCI / SMI Select**
- 0 **GPI16 Pin SCI / SMI Select**
 - 0 SCI on pin input change.....default
 - 1 SMI on pin input change

I/O Trap Registers

I/O Offset 57-54 – I/O Trap PCI Data RO

- 31-0 **PCI Data During I/O Trap SMI**

I/O Offset 59-58 – I/O Trap PCI I/O Address..... RO

- 15-0 **PCI Address During I/O Trap SMI**

I/O Offset 5A – I/O Trap PCI Command / Byte Enable RO

- 7-4 **PCI Command Type During I/O Trap SMI**
- 3-0 **PCI Byte Enable During I/O Trap SMI**

I/O Offset 5C – CPU Performance..... RO

- 7-1 **Reserved** always reads 0
- 0 **Lower CPU Frequency During C3 / S1**
This bit controls whether the CPU frequency is lowered when in C3/S1 state. The frequency is lowered using the GHI# signal (PMIO RxE5[3] must be 0 to enable the frequency change function).
 - 0 Disable (normal frequency during C3/S1)... def
 - 1 Enable (lower frequency during C3/S1)

System Management Bus I/O-Space Registers

The base address for these registers is defined in RxD1-D0 of the Device 17 Function 0 PCI configuration registers. The System Management Bus I/O space is enabled for access by the system if Device 17 Function 0 RxD2[0] = 1.

I/O Offset 00 – SMBus Host StatusRWC

- 7 **Reserved** always reads 0
- 6 **SMB Semaphore** **RWC**
This bit is used as a semaphore among various independent software threads that may need to use the Host SMBus logic and has no effect on hardware. After reset, this bit reads 0. Writing 1 to this bit causes the next read to return 0, then all reads after that return 1. Writing 0 to this bit has no effect. Software can therefore write 1 to request control and if readback is 0 then it will own usage of the host controller.
- 5 **Reserved** always reads 0
- 4 **Failed Bus Transaction**..... **RWC**
 - 0 SMBus interrupt not caused by failed bus transaction.....default
 - 1 SMBus interrupt caused by failed bus transaction. This bit may be set when the KILL bit (I/O Rx02[1]) is set and can be cleared by writing a 1 to this bit position.
- 3 **Bus Collision**..... **RWC**
 - 0 SMBus interrupt not caused by transaction collision.....default
 - 1 SMBus interrupt caused by transaction collision. This bit is only set by hardware and can be cleared by writing a 1 to this bit position.
- 2 **Device Error**..... **RWC**
 - 0 SMBus interrupt not caused by generation of an SMBus transaction error.....default
 - 1 SMBus interrupt caused by generation of an SMBus transaction error (illegal command field, unclaimed host-initiated cycle, or host device timeout). This bit is only set by hardware and can be cleared by writing a 1 to this bit position.
- 1 **SMBus Interrupt**..... **RWC**
 - 0 SMBus interrupt not caused by host command completiondefault
 - 1 SMBus interrupt caused by host command completion. This bit is only set by hardware and can be cleared by writing a 1 to this bit position.
- 0 **Host Busy** **RO**
 - 0 SMBus controller host interface is not processing a command.....default
 - 1 SMBus host controller is busy processing a command. None of the other SMBus registers should be accessed if this bit is set.

I/O Offset 01h – SMBus Slave Status.....RWC

- 7-6 **Reserved** always reads 0
- 5 **Alert Status** **RWC**
 - 0 SMBus interrupt not caused by SMBALERT# signal default
 - 1 SMBus interrupt caused by SMBALERT# signal. This bit will be set only if the Alert Enable bit is set in the SMBus Slave Control Register at I/O Offset R08[3]. This bit is only set by hardware and can be cleared by writing a 1 to this bit position.
- 4 **Shadow 2 Status** **RWC**
 - 0 SMBus interrupt not caused by address match to SMBus Shadow Address Port 2 default
 - 1 SMBus interrupt or resume event caused by slave cycle address match to SMBus Shadow Address Port 2. This bit is only set by hardware and can be cleared by writing a 1 to this bit position.
- 3 **Shadow 1 Status** **RWC**
 - 0 SMBus interrupt not caused by address match to SMBus Shadow Address Port 1 default
 - 1 SMBus interrupt or resume event caused by slave cycle address match to SMBus Shadow Address Port 1. This bit is only set by hardware and can be cleared by writing a 1 to this bit position.
- 2 **Slave Status** **RWC**
 - 0 SMBus interrupt not caused by slave event match default
 - 1 SMBus interrupt or resume event caused by slave cycle event match of the SMBus Slave Command Register at PCI Function 4 Configuration Offset D3h (command match) and the SMBus Slave Event Register at SMBus Base + Offset 0Ah (data event match). This bit is only set by hardware and can be cleared by writing a 1 to this bit position.
- 1 **Reserved** always reads 0
- 0 **Slave Busy** **RO**
 - 0 SMBus controller slave interface is not processing data default
 - 1 SMBus controller slave interface is busy receiving data. None of the other SMBus registers should be accessed if this bit is set.

I/O Offset 02h – SMBus Host Control..... RW

- 7 **Reserved** always reads 0
- 6 **Start** always reads 0
 - 0 Writing 0 has no effect.....default
 - 1 **Start Execution of Command**
Writing a 1 to this bit causes the SMBus controller host interface to initiate execution of the command programmed in the SMBus Command Protocol field (bits 4-2). All necessary registers should be programmed prior to writing a 1 to this bit. The Host Busy bit (SMBus Host Status Register bit-0) can be used to identify when the SMBus controller has completed command execution.

5-2 SMBus Command Protocol

Selects the type of command the SMBus host controller will execute. Reads or Writes are determined by Rx04[0].

- 0000 Quick default
- 0001 Byte
- 0010 Byte Data
- 0011 Word Data
- 0100 Process Call
- 0101 Block
- 0110 I2C with 10-bit Address
- 0111 -reserved-
- 10xx -reserved-
- 1100 I2C Process Call
- 1101 I2C Block
- 1110 I2C with 7-bit Address
- 1111 Universal

1 Kill Transaction in Progress

- 0 Normal host controller operationdefault
- 1 **Stop host transaction currently in progress.**
Setting this bit also sets the FAILED status bit (Host Status bit-4) and asserts the interrupt selected by the SMB Interrupt Select bit (Function 4 SMBus Host Configuration Register Rx02[3]).

0 Interrupt Enable

- 0 Disable interrupt generation.....default
- 1 Enable generation of interrupts on completion of the current host transaction.

I/O Offset 03h – SMBus Host Command RW

- 7-0 **SMBUS Host Command** default = 0
This field contains the data transmitted in the command field of the SMBus host transaction.

I/O Offset 04h – SMBus Host Address RW

The contents of this register are transmitted in the address field of the SMBus host transaction.

- 7-1 **SMBUS Address** default = 0
This field contains the 7-bit address of the targeted slave device.

0 SMBUS Read or Write

- 0 Execute a WRITE command default
- 1 Execute a READ command

I/O Offset 05h – SMBus Host Data 0 RW

The contents of this register are transmitted in the Data 0 field of SMBus host transaction writes. On reads, Data 0 bytes are stored here.

- 7-0 **SMBUS Data 0** default = 0
For Block Write commands, this field is programmed with the block transfer count (a value between 1 and 32). Counts of 0 or greater than 32 are undefined. For Block Read commands, the count received from the SMBus device is stored here.

I/O Offset 06h – SMBus Host Data 1 RW

The contents of this register are transmitted in the Data 1 field of SMBus host transaction writes. On reads, Data 1 bytes are stored here.

- 7-0 **SMBUS Data 1** default = 0

I/O Offset 07h – SMBus Block Data RW

Reads and writes to this register are used to access the 32-byte block data storage array. An internal index pointer is used to address the array. It is reset to 0 by reads of the SMBus Host Control register (I/O Offset 2) and incremented automatically by each access to this register. The transfer of block data into (read) or out of (write) this storage array during an SMBus transaction always starts at index address 0.

- 7-0 **SMBUS Block Data** default = 0

I/O Offset 08h – SMBus Slave Control.....RW

- 7-4 **Reserved** always reads 0
- 3 **SMBus Alert Enable**
 - 0 Disabledefault
 - 1 Enable generation of an interrupt or resume event on the assertion of the SMBALERT# signal
- 2 **SMBus Shadow Port 2 Enable**
 - 0 Disabledefault
 - 1 Enable generation of an interrupt or resume event on external SMBus master generation of a transaction with an address that matches the SMBus Slave Shadow Port 2 register (PCI function 4 configuration register RxD5).
- 1 **SMBus Shadow Port 1 Enable**
 - 0 Disabledefault
 - 1 Enable generation of an interrupt or resume event on external SMBus master generation of a transaction with an address that matches the SMBus Slave Shadow Port 1 register (PCI function 4 configuration register RxD4).
- 0 **SMBus Slave Enable**
 - 0 Disabledefault
 - 1 Enable generation of an interrupt or resume event on external SMBus master generation of a transaction with an address that matches the SMBus host controller slave port of 10h, a command field which matches the SMBus Slave Command register (PCI function 4 configuration register RxD3), and a match of one of the corresponding enabled events in the SMBus Slave Event Register (I/O Offset 0Ah).

I/O Offset 09h – SMBus Shadow CommandRO

This register is used to store command values for external SMBus master accesses to the host slave and slave shadow ports.

- 7-0 **Shadow Command**..... default = 0
This field contains the command value which was received during an external SMBus master access whose address field matched the host slave address (10h) or one of the slave shadow port addresses.

I/O Offset 0B-0Ah – SMBus Slave Event RW

This register is used to enable generation of interrupt or resume events for accesses to the host controller’s slave port.

- 15-0 **SMBus Slave Event** default = 0
This field contains data bits used to compare against incoming data to the SMBus Slave Data Register (I/O Offset 0Ch). When a bit in this register is set and the corresponding bit the Slave Data register is also set, an interrupt or resume event will be generated if the command value matches the value in the SMBus Slave Command register and the access was to SMBus host address 10h.

I/O Offset 0D-0Ch – SMBus Slave Data RO

This register is used to store data values for external SMBus master accesses to the shadow ports or the SMBus host controller’s slave port.

- 15-0 **SMBus Slave Data** default = 0
This field contains the data value which was transmitted during an external SMBus master access whose address field matched one of the slave shadow port addresses or the SMBus host controller slave port address of 10h.

Device 17 Function 1 Registers - Enhanced IDE Controller

This Enhanced IDE controller interface is fully compatible with the SFF 8038i v.1.0 specification. There are two sets of software accessible registers -- PCI configuration registers and Bus Master IDE I/O registers. The PCI configuration registers are located in the function 1 PCI configuration space of the VT8233A. The Bus Master IDE I/O registers are defined in the SFF8038i v1.0 specification.

PCI Configuration Space Header

Offset 1-0 - Vendor ID (1106h=VIA).....RO

Offset 3-2 - Device ID (0571h=IDE Controller).....RO

Offset 5-4 – Command (0000h).....RW

- 15-3 **Reserved** always reads 0
- 2 **Bus Master** default = 0 (disabled)
S/G operation can be issued only when the “Bus Master” bit is enabled.
- 1 **Reserved** always reads 0
- 0 **I/O Space** default = 0 (disabled)
When the “I/O Space” bit is disabled, the device will not respond to any I/O addresses for both compatible and native mode.

Offset 7-6 – Status (0290h).....RO

- 15 **Detected Parity Error** fixed at 0
- 14 **Signalled System Error** fixed at 0
- 13 **Received Master Abort**..... fixed at 0
- 12 **Received Target Abort** fixed at 0
- 11 **Signalled Target Abort**..... fixed at 0
- 10-9 **DEVSEL# Timing**..... always reads 01 (medium)
- 8 **Data Parity Detected**..... fixed at 0
- 7 **Fast Back to Back** fixed at 1
- 6-5 **Reserved** always reads 0
- 4 **Capability List**..... fixed at 1
- 3-0 **Reserved** always reads 0

Offset 8 - Revision ID (06).....RO

- 7-0 **Revision Code for IDE Controller Logic Block**

Offset 9 - Programming Interface..... RW

- 7 **Master IDE Capability** fixed at 1 (Supported)
- 6-4 **Reserved** always reads 0
- 3 **Programmable Indicator - Secondary**..... fixed at 1
Supports both modes (may be set to either mode by writing Rx42[6])
- 2 **Channel Operating Mode - Secondary**
0 Compatibility Mode default
1 Native Mode
- 1 **Programmable Indicator - Primary** fixed at 1
Supports both modes (may be set to either mode by writing Rx42[7])
- 0 **Channel Operating Mode - Primary**
0 Compatibility Mode default
1 Native Mode

Compatibility Mode (fixed IRQs and I/O addresses):

Channel	Command Block	Control Block	
	Registers	Registers	IRQ
Pri	1F0-1F7	3F6	14
Sec	170-177	376	15

Native PCI Mode (registers are programmable in I/O space)

Channel	Command Block	Control Block
	Registers	Registers
Pri	BA @offset 10h	BA @offset 14h
Sec	BA @offset 18h	BA @offset 1Ch

Command register blocks are 8 bytes of I/O space
Control registers are 4 bytes of I/O space (only byte 2 is used)

Offset A - Sub Class Code (01h=IDE Controller)..... RO

Offset B - Base Class Code (01h=Mass Storage Ctrlr)... RO

Offset 13-10 - Pri Data / Command Base AddressRW

Specifies an 8 byte I/O address space.

- 31-16 **Reserved**always read 0
- 15-3 **Port Address**..... default=01F0h
- 2-0 **Fixed at 001b**fixed

Offset 17-14 - Pri Control / Status Base AddressRW

Specifies a 4 byte I/O address space of which only the third byte is active (i.e., 3F6h for the default base address of 3F4h).

- 31-16 **Reserved**always read 0
- 15-2 **Port Address**..... default=03F4h
- 1-0 **Fixed at 01b**fixed

Offset 1B-18 - Sec Data / Command Base AddressRW

Specifies an 8 byte I/O address space.

- 31-16 **Reserved**always read 0
- 15-3 **Port Address** default=0170h
- 2-0 **Fixed at 001b**fixed

Offset 1F-1C - Sec Control / Status Base Address.....RW

Specifies a 4 byte I/O address space of which only the third byte is active (i.e., 376h for the default base address of 374h).

- 31-16 **Reserved**always read 0
- 15-2 **Port Address** default=0374h
- 1-0 **Fixed at 01b**fixed

Offset 23-20 - Bus Master Control Regs Base Address..RW

Specifies a 16 byte I/O address space compliant with the SFF-8038i rev 1.0 specification.

- 31-16 **Reserved**always read 0
- 15-4 **Port Address** default=CC0h
- 3-0 **Fixed at 0001b**fixed

See Rx42[7-6] for Native / Compatibility mode select for the above registers

Offset 2D-2C – Sub Vendor ID (0000h)..... RO

The readback value may be changed by writing to RxD5-D4.

Offset 2F-2E – Sub Device ID (0000h)..... RO

The readback value may be changed by writing to RxD7-D6.

Offset 34 - Capability Pointer (C0h)..... RO

Offset 3C - Interrupt Line (0Eh)..... RO

- 7-4 **Reserved** always read 0
- 3-0 **IDE Interrupt Routing** (for native mode)
 - 0000 Disable
 - 0001 IRQ1
 - 0010 IRQ2
 -
 - 1101 IRQ13
 - 1110 IRQ14 default
 - 1111 IRQ15
 - APIC (See Device 17 Function 0 Rx4D[7])
 - x000 IRQ16
 - x001 IRQ17
 - x010 IRQ18
 -
 - x111 IRQ23

Offset 3D - Interrupt Pin (00h)..... RO

- 7-0 **Interrupt Routing Mode**
 - 00h Legacy mode interrupt routing default
 - 01h Native mode interrupt routing

Offset 3E - Minimum Grant (00h) RO

Offset 3F - Maximum Latency (00h)..... RO

IDE-Controller-Specific Configuration Registers

Offset 40 - Chip EnableRW

- 7-2 **Reserved** always reads 0
- 1 **Primary Channel**
 - 0 Disabledefault
 - 1 Enable
- 0 **Secondary Channel**
 - 0 Disabledefault
 - 1 Enable

Offset 41 - IDE Configuration I.....RW

- 7 **Primary IDE Read Prefetch Buffer**
 - 0 Disabledefault
 - 1 Enable
- 6 **Primary IDE Post Write Buffer**
 - 0 Disabledefault
 - 1 Enable
- 5 **Secondary IDE Read Prefetch Buffer**
 - 0 Disabledefault
 - 1 Enable
- 4 **Secondary IDE Post Write Buffer**
 - 0 Disabledefault
 - 1 Enable
- 3-0 **Reserved** always reads 0

Offset 42 - IDE Configuration II.....RW

- 7 **PIO Operating Mode - Primary Channel**
Selects the mode used in the primary channel for the I/O Base Address (not IRQ routing or sharing)
 - 0 Compatibility Mode (fixed addressing) .default
 - 1 Native PCI Mode (flexible addressing)
- 6 **PIO Operating Mode - Secondary Channel**
Selects the mode used in the secondary channel for the I/O Base Address (not IRQ routing or sharing)
 - 0 Compatibility Mode (fixed addressing) .default
 - 1 Native PCI Mode (flexible addressing)
- 5-0 **Reserved** always reads 0

Offset 43 - FIFO Configuration..... RW

- 7-4 **Reserved**always reads 0
- 3-2 **Primary Channel FIFO Threshold**
Determines the threshold required before the primary channel FIFO is flushed.
 - 00 FIFO flushed when 1/4 full
 - 01 FIFO flushed when 1/2 full
 - 10 FIFO flushed when 3/4 full default
 - 11 FIFO flushed when completely full (32 DWs)
- 1-0 **Secondary Channel FIFO Threshold**
Determines the threshold required before the secondary channel FIFO is flushed.
 - 00 FIFO flushed when 1/4 full
 - 01 FIFO flushed when 1/2 full
 - 10 FIFO flushed when 3/4 full default
 - 11 FIFO flushed when completely full (32 DWs)

Offset 44 - Miscellaneous Control 1.....RW

- 7-5 **Reserved** always reads 0
- 4 **PIO Read Pre-Fetch Byte Counter**
Determines whether the amount of data prefetched under PIO read is limited.
 - 0 Disable (no limit)default
 - 1 Enable. The maximum number of bytes that can be prefetched is determined by Rx61-60[11:0] for the primary channel and Rx69-68[11:0] for the secondary channel.
- 3 **Bus Master IDE Status Register Read Retry**
Determines whether a read to the bus master IDE status register is retried when DMA operation is not complete.
 - 0 Disable. Reads will return status even if DMA operation is not complete.
 - 1 Enable. Reads of the status register are automatically retried while DMA operation is not complete.....**default**
- 2 **Packet Command Prefetching**
Determines whether prefetching is enabled for packet commands. Packet commands are commands for ATAPI, which is used for operating devices such as CD-ROM drives.
 - 0 Disabledefault
 - 1 Enable
- 1 **Reserved** always reads 0
- 0 **UltraDMA Host Must Wait for First Transfer Before Termination**
 - 0 Enable. The UltraDMA host must wait until at least the first transfer is completed before it can terminate a transaction.....default
 - 1 Disable

Offset 45 - Miscellaneous Control 2 RW

- 7 **Reserved**always reads 0
- 6 **Interrupt Steering Swap**
Controls whether primary and secondary channel interrupts are swapped.
 - 0 Primary channel interrupt is steered to IRQ14, Secondary channel is steered to IRQ15. default
 - 1 Primary channel interrupt is steered to IRQ15, Secondary channel interrupt steered to IRQ14
- 5 **Reserved**always reads 1
- 4 **Rx3C Write Protect**
 - 0 Disable (writes to Rx3C are allowed).... default
 - 1 Enable (writes to Rx3C are ignored). Under Native Mode (Rx9[2]=1 or Rx9[0]=1) Rx3C should not be write protected as it is used to route IRQ lines.
- 3 **“Memory-Read-Multiple” Command**
 - 0 Disable..... default
 - 1 Enable
- 2 **“Memory-Write-and-Invalidate” Command**
 - 0 Disable..... default
 - 1 Enable
- 1-0 **Reserved**always reads 0

Offset 46 - Miscellaneous Control 3 RW

- 7 **Primary Channel Read DMA FIFO Flush**
 - 0 Disable
 - 1 Enable. The primary channel DMA FIFO is flushed when an interrupt request is generated default
- 6 **Secondary Channel Read DMA FIFO Flush**
 - 0 Disable
 - 1 Enable. The secondary channel DMA FIFO is flushed when an interrupt request is generated default
- 5-0 **Reserved**always reads 0

Offset 4B-48 - Drive Timing Control.....RW

The following fields define the Active Pulse Width and Recovery Time for the IDE DIOR# and DIOW# signals when accessing the data ports (1F0 and 170):

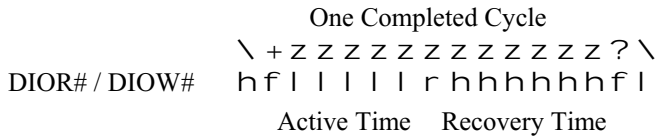

- 31-28 Primary Drive 0 Active Pulse Width..... def=1010b
- 27-24 Primary Drive 0 Recovery Time..... def=1000b
- 23-20 Primary Drive 1 Active Pulse Width..... def=1010b
- 19-16 Primary Drive 1 Recovery Time..... def=1000b
- 15-12 Secondary Drive 0 Active Pulse Width.. def=1010b
- 11-8 Secondary Drive 0 Recovery Time def=1000b
- 7-4 Secondary Drive 1 Active Pulse Width.. def=1010b
- 3-0 Secondary Drive 1 Recovery Time def=1000b

The actual value for each field is the encoded value in the field plus one and indicates the number of PCI clocks. For example, if the value in the field is 1010b (10 decimal), the active pulse width or recovery time is 11 PCI clocks.

Offset 4C - Address Setup TimeRW

The following fields define the Address Setup Time. The Address Setup Time is measured from the point when address signals are stable to the point when DIOR# and DIOW# are asserted. The IDE specification requires the setup time to not exceed 1T. However, the VT8233 provides flexibility for devices that may not be able to meet the 1T requirement.

- 7-6 Primary Drive 0 Address Setup Time
- 5-4 Primary Drive 1 Address Setup Time
- 3-2 Secondary Drive 0 Address Setup Time
- 1-0 Secondary Drive 1 Address Setup Time

For each field above:

- 00 1T
- 01 2T
- 10 3T
- 11 4Tdefault

Offset 4E – Sec Non-1F0 Port Access Timing.....RW

- 7-4 DIOR# / DIOW# Active Pulse Width.....def = 0Bh
- 3-0 DIOR# / DIOW# Recovery Time def = 06h

Offset 4F – Pri Non-1F0 Port Access Timing.....RW

- 7-4 DIOR# / DIOW# Active Pulse Width.....def = 0Bh
- 3-0 DIOR# / DIOW# Recovery Time def = 06h

The above fields define the primary and secondary channel DIOR# and DIOW# active pulse widths and recovery times when accessing non-data ports. The times are defined in terms of PCI clocks and the actual value is equal to the value encoded in the field plus one.

Offset 53-50 - UltraDMA Extended Timing Control..... RW

- 31 Pri Drive 0 UltraDMA-Mode Enable Method
 - 0 Enable by using “Set Feature” command def
 - 1 Enable by setting bit-30 of this register
- 30 Pri Drive 0 UltraDMA-Mode Enable
 - 0 Disable..... default
 - 1 Enable UltraDMA-Mode Operation
- 29 Pri Drive 0 Transfer Mode
 - 0 DMA or PIO Mode default
 - 1 UltraDMA Mode
- 28 Pri Drive 0 Cable Type Reporting
 - 0 40-pin cable is being used default
 - 1 80-pin cable is being used
- 27-24 Pri Drive 0 Cycle Time (T = 7.5 ns for 133 MHz)

(T = 10 ns for 100 MHz in 8233 and 8233C)

 - 0000 2T
 - 0001 3T
 - 0010 4T
 - 0011 5T
 - 0100 6T
 - 0101 7T
 - 0110 8T
 - 0111 9T default
 - 1000 10T
 - 1001 11T
 - 1010 12T
 - 1011 13T
 - 1100 14T
 - 1101 15T
 - 1110 16T
 - 1111 17T

- 23 Pri Drive 1 UltraDMA-Mode Enable Method
- 22 Pri Drive 1 UltraDMA-Mode Enable
- 21 Pri Drive 1 Transfer Mode
- 20 Pri Drive 1 Cable Type Reporting
 - 0 40-pin cable is being used default
 - 1 80-pin cable is being used
- 19-16 Pri Drive 1 Cycle Time
- 15 Sec Drive 0 UltraDMA-Mode Enable Method
- 14 Sec Drive 0 UltraDMA-Mode Enable
- 13 Sec Drive 0 Transfer Mode
- 12 Sec Drive 0 Cable Type Reporting
 - 0 40-pin cable is being used default
 - 1 80-pin cable is being used
- 11-8 Sec Drive 0 Cycle Time
- 7 Sec Drive 1 UltraDMA-Mode Enable Method
- 6 Sec Drive 1 UltraDMA-Mode Enable
- 5 Sec Drive 1 Transfer Mode
- 4 Sec Drive 1 Cable Type Reporting
 - 0 40-pin cable is being used default
 - 1 80-pin cable is being used
- 3-0 Sec Drive 1 Cycle Time

Each byte defines UltraDMA operation for the indicated drive. The bit definitions are the same within each byte.

Offset 54 – UltraDMA FIFO Control (04h).....RW

- 7 **Reserved** always reads 0
- 6 **Lower ISA Request Priority When Write Device Packet Command is Issued**
The IDE secondary channel shares a bus internally with the ISA interface. When this bit is enabled, the IDE secondary channel is given higher priority over ISA, which results in better performance.
0 Disabledefault
1 Enable
- 5 **Clear Native Mode Interrupt on Falling Edge of Gated Interrupt**
0 Disabledefault
1 Enable. The interrupt will be automatically cleared on the falling edge of the gated interrupt.
- 4 **Improve PIO Prefetch and Post-Write Performance**
0 Enable. PIO prefetch and post write performance is increased by being given higher throughput.....default
1 Disable
- 3 **Memory Prefetch Size**
This bit determines how many lines are prefetched from memory for IDE transactions.
0 Prefetch 1 linedefault
1 Prefetch 3 lines (24 DoubleWords). This setting improves ATA100 / 133 throughput.
- 2 **Change Drive Clears All FIFO & Internal States**
0 Disable
1 Command switch from one drive to another drive in the same channel terminates all previous outstanding transactions involving the previous drive.....**default**
- 1 **Reserved** always reads 0
- 0 **Complete DMA Cycle with Transfer Size Less Than FIFO Size**
0 Enable. DMA transfer size is less than the FIFO size.....default
1 Disable

Offset 61-60 - Primary Sector SizeRW

- 15-12 **Reserved** always reads 0
- 11-0 **Number of Bytes Per Sector...** def=200h (512 bytes)
This field determines the maximum number of bytes that can be prefetched when Rx44[4] = 1.

Offset 69-68 - Secondary Sector SizeRW

- 15-12 **Reserved** always reads 0
- 11-0 **Number of Bytes Per Sector...** def=200h (512 bytes)
This field determines the maximum number of bytes that can be prefetched when Rx44[4] = 1.

Offset 70 – Primary IDE Status..... RO

- 7 **Interrupt Status**..... RO
1 Primary channel interrupt request pending
- 6 **Prefetch Buffer Status**..... RO
1 PIO Prefetch transaction in progress
- 5 **Post Write Buffer Status**..... RO
1 PIO Post Write transaction in progress
- 4 **DMA Read Prefetch Status** RO
1 DMA Read Prefetch transaction in progress
- 3 **DMA Write Pipeline Status**..... RO
1 DMA Write transaction in progress
- 2 **S/G Operation Complete** RO
1 Scatter / Gather operation complete
- 1 **FIFO Empty Status**..... RO
1 Primary Channel FIFO empty
- 0 **Response to External DMA Request** RO
1 External pri channel DMA request pending

Offset 71 – Primary Interrupt Control (01h)..... RW

- 7-1 **Reserved** always reads 0
- 0 **Interrupt Gating**
0 Disable
1 Enable (IRQ output gated until FIFO empty)
..... **default**

Offset 78 – Secondary IDE Status..... RO

- 7 **Interrupt Status**..... RO
1 Secondary channel interrupt request pending
- 6 **Prefetch Buffer Status**..... RO
1 PIO Prefetch transaction in progress
- 5 **Post Write Buffer Status**..... RO
1 PIO Post Write transaction in progress
- 4 **DMA Read Prefetch Status** RO
1 DMA Read Prefetch transaction in progress
- 3 **DMA Write Pipeline Status**..... RO
1 DMA Write transaction in progress
- 2 **S/G Operation Complete** RO
1 Scatter / Gather operation complete
- 1 **FIFO Empty Status**..... RO
1 Secondary Channel FIFO empty
- 0 **Response to External DMA Request** RO
1 External sec channel DMA request pending

Offset 79 - Secondary Interrupt Control (01h)..... RW

- 7-1 **Reserved** always reads 0
- 0 **Interrupt Gating**
0 Disable
1 Enable (IRQ output gated until FIFO empty)
..... **default**

Offset 83-80 – Primary S/G Descriptor Address..... RO

Offset 8B-88 – Secondary S/G Descriptor Address RO

These registers are used for debugging purposes only.

IDE Power Management Registers

Offset C3-C0 – Power Management Capabilities.....RO

31-0 PCI PM Block 1 always reads 0002 0001h
 This field reports support details for Power Management Capabilities according to the PCI Power Management specification.

Offset C7-C4 – Power State.....RO

31-2 Reserved always reads 0
1-0 Power State
 00 D0default
 01 -reserved-
 10 -reserved-
 11 D3 Hot

IDE Back Door Registers

Offset D0 – Back Door – Revision ID (06h)RW

Offset D3-D2 – Back Door – Device ID (0571h)RW

Offset D5-D4 – Back Door – Sub-Vendor ID (0000h)....RW

Offset D7-D6 – Back Door – Sub-Device ID (0000h)RW

IDE I/O Registers

These registers are compliant with the SFF 8038I v1.0 standard. Refer to the SFF 8038I v1.0 specification for further details.

I/O Offset 0 - Primary Channel Command

I/O Offset 2 - Primary Channel Status

I/O Offset 4-7 - Primary Channel PRD Table Address

I/O Offset 8 - Secondary Channel Command

I/O Offset A - Secondary Channel Status

I/O Offset C-F - Secondary Channel PRD Table Address

Device 17 Function 2 Registers - USB Controller Ports 0-1

This Universal Serial Bus host controller interface is fully compatible with UHCI specification v1.1. There are two sets of software accessible registers: PCI configuration registers and USB I/O registers. The PCI configuration registers are located in the function 2 PCI configuration space of the VT8233A. The USB I/O registers are defined in UHCI specification v1.1. The registers in this function control USB ports 0-1 (see function 3 for ports 2-3 and function 4 for ports 4-5).

PCI Configuration Space Header

Offset 1-0 - Vendor IDRO

7-0 Vendor ID (1106h = VIA Technologies)

Offset 3-2 - Device ID.....RO

7-0 Device ID (3038h = VT8233A USB Controller)

Offset 5-4 - Command.....RW

- 15-8 Reserved always reads 0
- 7 Reserved (address stepping)fixed at 0
- 6 Reserved (parity error response).....fixed at 0
- 5 Reserved (VGA palette snoop).....fixed at 0
- 4 Reserved (memory write and invalidate).....fixed at 0
- 3 Reserved (special cycle monitoring).....fixed at 0
- 2 Bus Masterfixed at 0
- 1 Memory Space.....fixed at 0
- 0 I/O Space default=0 (disabled)

Offset 7-6 - Status.....RWC

- 15 Reserved (detected parity error)..... always reads 0
- 14 Signalled System Error default=0
- 13 Received Master Abort..... default=0
- 12 Received Target Abort default=0
- 11 Signalled Target Abort..... default=0
- 10-9 DEVSEL# Timing
 - 00 Fast
 - 01 Medium.....default (fixed)
 - 10 Slow
 - 11 Reserved
- 8-0 Reserved always reads 0

Offset 8 - Revision ID (nnh)..... RO

- 7-0 Silicon Revision Code (0 indicates first silicon)
06h Corresponds to Chip Revision D

Offset 9 - Programming Interface (00h)..... RO

Offset A - Sub Class Code (03h=USB Controller)..... RO

Offset B - Base Class Code (0Ch=Serial Bus Controller)RO

Offset 23-20 - USB I/O Register Base Address RW

- 31-16 Reservedalways reads 0
- 15-5 USB I/O Register Base Address. Port Address for the base of the 32-byte USB I/O Register block, corresponding to AD[15:5]
- 4-0 00001b

Offset 2D-2C – Sub Vendor ID (0000h)..... RO

Offset 2F-2E – Sub Device ID (0000h)..... RO

Offset 3C - Interrupt Line (00h)..... RW

- 7-4 Reservedalways reads 0
- 3-0 USB Interrupt Routing
 - 0000 Disabled..... default
 - 0001 IRQ1
 - 0010 Reserved
 - 0011 IRQ3
 - 0100 IRQ4
 - 0101 IRQ5
 - 0110 IRQ6
 - 0111 IRQ7
 - 1000 IRQ8
 - 1001 IRQ9
 - 1010 IRQ10
 - 1011 IRQ11
 - 1100 IRQ12
 - 1101 IRQ13
 - 1110 IRQ14
 - 1111 Disabled

Offset 3D - Interrupt Pin (04h)..... RO

- 7-0 Interrupt Pin.....always reads 04h to indicate INTC#

USB-Specific Configuration Registers

Offset 40 - Miscellaneous Control 1.....RW

- 7 **Reserved** always reads 0
- 6 **Babble Option**
This bit controls whether the port is disabled when EOF (End-Of-Frame) babble occurs. Babble is unexpected bus activity that persists into the EOF interval. When this bit is 0, the port with the EOF babble is disabled. When it is 1, it is not disabled
 - 0 Automatically disable babbled port when EOF babble occursdefault
 - 1 Don't disable babbled port
- 5 **Reserved** always reads 0
- 4 **Reserved (Do Not Program)**..... default = 0
- 3 **USB Data Length Option**
 - 0 Support TD length up to 1280.....default
 - 1 Support TD length up to 1023
(TD = Transfer Descriptor)
- 2 **Reserved** always reads 0
- 1 **DMA Option**
 - 0 Enhanced performance (8 DW burst access with better FIFO latency).....default
 - 1 Normal performance (16 DW burst access with normal FIFO latency)
- 0 **PCI Wait States**
 - 0 Zero Wait States.....default
 - 1 One Wait State

Offset 41 - Miscellaneous Control 2..... RW

- 7 **USB 1.1 Improvement for EOP**
This bit controls whether USB Specification 1.1 or 1.0 is followed when a stuffing error occurs before an EOP (End-Of-Packet). A stuffing error results when the receiver sees seven consecutive ones in a packet. Under USB specification 1.1, when this occurs in the interval just before an EOP, the receiver will accept the packet. Under USB specification 1.0, the packet is ignored.
 - 0 USB Spec 1.1 Compliant (packet accepted) def
 - 1 USB Spec 1.0 Compliant (packet ignored)
- 6-3 **Reserved (Do Not Program)**..... default = 0
- 2 **Trap Option**
Under the UHCI spec, port 60 / 64 is trapped only when its corresponding enable bits are set. When this bit is set, trap can be set without checking the enable bits.
 - 0 Set trap 60/64 status bits only when trap 60/64 enable bits are set default
 - 1 Set trap 60/64 status bits without checking enable bits
- 1 **A20Gate Pass Through Option**
This bit controls whether the A20Gate pass-through sequence (as defined in UHCI) is followed. The A20Gate sequence consists of 4 commands. When this bit is 0, the 4-command sequence is followed. When this bit is 1, the last command (write FFh to port 64) is skipped.
 - 0 A20GATE Pass-through command sequence as defined in UHCI..... default
 - 1 Last command skipped
- 0 **Reserved**always reads 0

Offset 48 - Miscellaneous Control 3.....RW

- 7-4 **Reserved** always reads 0
- 3-2 **Reserved (Do Not Program)**..... default = 0
- 1 **Lengthen PreSOF Time**
The preSOF time point determines whether there is enough time in the remaining frame period to perform a 64-byte transaction. It prevents a packet that may not fit in the remaining frame period from being initiated. This bit controls whether the preSOF time point is moved back so that the preSOF time is lengthened.
 - 0 Disabledefault
 - 1 Enable (PreSOF time lengthened)
- 0 **Issue Nonzero Bad CRC Code on FIFO Underrun**
A FIFO underrun occurs when there is no data in the FIFO to supply data transmission. When this occurs, the south bridge invalidates the data by sending an incorrect CRC code to the device. This bit controls the type of incorrect CRC sent.
 - 0 Non zero CRC (recommended).....default
 - 1 All zero CRC

This option isn't really needed any more as non-zero CRC always works.

Offset 49 – MIA Analog Control.....RW

- 7-3 **Reserved** always reads 0
- 2 **Reserved (Do Not Program)**..... default = 0
- 1-0 **Port Slew Rate Control**
This field controls the slew rate of signals from the port. The voltage values are Pn+ and Pn- crossover-point voltages. The different crossover points are generated by controlling the rising edge of both Pn+ and Pn- signals.
 - 00 1.50Vdefault
 - 01 1.65V
 - 10 1.80V
 - 11 1.95V

Offset 60 - Serial Bus Release Number.....RO

- 7-0 **Release Number** always reads 10h

Offset 83-80 – PM Capability.....RO

- 31-0 **PM Capability** always reads 00020001h

Offset 84 – PM Capability StatusRW

- 7-0 **PM Capability Status**
 - 00 D0default
 - 11 D3 Hot

Offset C1-C0 - Legacy Support.....RO

- 15-0 **UHCI v1.1 Compliant**..... always reads 2000h

USB I/O Registers

These registers are compliant with the UHCI v1.1 standard. Refer to the UHCI v1.1 specification for further details.

I/O Offset 1-0 - USB Command

I/O Offset 3-2 - USB Status

I/O Offset 5-4 - USB Interrupt Enable

I/O Offset 7-6 - Frame Number

I/O Offset B-8 - Frame List Base Address

I/O Offset 0C - Start Of Frame Modify

I/O Offset 11-10 - Port 0 Status / Control

I/O Offset 13-12 - Port 1 Status / Control

Device 17 Function 3 Registers - USB Controller Ports 2-3

This Universal Serial Bus host controller interface is fully compatible with UHCI specification v1.1. There are two sets of software accessible registers: PCI configuration registers and USB I/O registers. The PCI configuration registers are located in the function 3 PCI configuration space of the VT8233A. The USB I/O registers are defined in UHCI specification v1.1. The registers in this function control USB ports 2-3 (see function 2 for ports 0-1 and function 4 for ports 4-5).

PCI Configuration Space Header

Offset 1-0 - Vendor IDRO

7-0 Vendor ID (1106h = VIA Technologies)

Offset 3-2 - Device ID.....RO

7-0 Device ID (3038h = VT8233A USB Controller)

Offset 5-4 - Command.....RW

- 15-8 Reserved always reads 0
- 7 Reserved (address stepping)fixed at 0
- 6 Reserved (parity error response).....fixed at 0
- 5 Reserved (VGA palette snoop).....fixed at 0
- 4 Reserved (memory write and invalidate).....fixed at 0
- 3 Reserved (special cycle monitoring).....fixed at 0
- 2 Bus Masterfixed at 0
- 1 Memory Space.....fixed at 0
- 0 I/O Space default=0 (disabled)

Offset 7-6 - Status.....RWC

- 15 Reserved (detected parity error)..... always reads 0
- 14 Signalled System Error default=0
- 13 Received Master Abort..... default=0
- 12 Received Target Abort default=0
- 11 Signalled Target Abort..... default=0
- 10-9 DEVSEL# Timing
 - 00 Fast
 - 01 Medium.....default (fixed)
 - 10 Slow
 - 11 Reserved
- 8-0 Reserved always reads 0

Offset 8 - Revision ID (nnh)..... RO

7-0 Silicon Revision Code (0 indicates first silicon)

Offset 9 - Programming Interface (00h)..... RO

Offset A - Sub Class Code (03h=USB Controller)..... RO

Offset B - Base Class Code (0Ch=Serial Bus Controller)RO

Offset 23-20 - USB I/O Register Base Address RW

- 31-16 Reservedalways reads 0
- 15-5 USB I/O Register Base Address. Port Address for the base of the 32-byte USB I/O Register block, corresponding to AD[15:5]
- 4-0 00001b

Offset 2D-2C – Sub Vendor ID (0000h)..... RO

Offset 2F-2E – Sub Device ID (0000h)..... RO

Offset 3C - Interrupt Line (00h)..... RW

- 7-4 Reservedalways reads 0
- 3-0 USB Interrupt Routing default = 16h
 - 0000 Disabled..... default
 - 0001 IRQ1
 - 0010 Reserved
 - 0011 IRQ3
 - 0100 IRQ4
 - 0101 IRQ5
 - 0110 IRQ6
 - 0111 IRQ7
 - 1000 IRQ8
 - 1001 IRQ9
 - 1010 IRQ10
 - 1011 IRQ11
 - 1100 IRQ12
 - 1101 IRQ13
 - 1110 IRQ14
 - 1111 Disabled

Offset 3D - Interrupt Pin (04h)..... RO

USB-Specific Configuration Registers

Offset 40 - Miscellaneous Control 1.....RW

- 7 **Reserved** always reads 0
- 6 **Babble Option**
This bit controls whether the port is disabled when EOF (End-Of-Frame) babble occurs. Babble is unexpected bus activity that persists into the EOF interval. When this bit is 0, the port with the EOF babble is disabled. When it is 1, it is not disabled
 - 0 Automatically disable babbled port when EOF babble occursdefault
 - 1 Don't disable babbled port
- 5 **Reserved** always reads 0
- 4 **Reserved (Do Not Program)**..... default = 0
- 3 **USB Data Length Option**
 - 0 Support TD length up to 1280.....default
 - 1 Support TD length up to 1023
(TD = Transfer Descriptor)
- 2 **Reserved** always reads 0
- 1 **DMA Option**
 - 0 Enhanced performance (8 DW burst access with better FIFO latency).....default
 - 1 Normal performance (16 DW burst access with normal FIFO latency)
- 0 **PCI Wait States**
 - 0 Zero Wait States.....default
 - 1 One Wait State

Offset 41 - Miscellaneous Control 2..... RW

- 7 **USB 1.1 Improvement for EOP**
This bit controls whether USB Specification 1.1 or 1.0 is followed when a stuffing error occurs before an EOP (End-Of-Packet). A stuffing error results when the receiver sees seven consecutive ones in a packet. Under USB specification 1.1, when this occurs in the interval just before an EOP, the receiver will accept the packet. Under USB specification 1.0, the packet is ignored.
 - 0 USB Spec 1.1 Compliant (packet accepted) def
 - 1 USB Spec 1.0 Compliant (packet ignored)
- 6-3 **Reserved (Do Not Program)**..... default = 0
- 2 **Trap Option**
Under the UHCI spec, port 60 / 64 is trapped only when its corresponding enable bits are set. When this bit is set, trap can be set without checking the enable bits.
 - 0 Set trap 60/64 status bits only when trap 60/64 enable bits are set default
 - 1 Set trap 60/64 status bits without checking enable bits
- 1 **A20Gate Pass Through Option**
This bit controls whether the A20Gate pass-through sequence (as defined in UHCI) is followed. The A20Gate sequence consists of 4 commands. When this bit is 0, the 4-command sequence is followed. When this bit is 1, the last command (write FFh to port 64) is skipped.
 - 0 A20GATE Pass-through command sequence as defined in UHCI..... default
 - 1 Last command skipped
- 0 **Reserved**always reads 0

Offset 48 - Miscellaneous Control 3.....RW

- 7-4 **Reserved** always reads 0
- 3-2 **Reserved (Do Not Program)**..... default = 0
 - 1 **Lengthen PreSOF Time**
The preSOF time point determines whether there is enough time in the remaining frame period to perform a 64-byte transaction. It prevents a packet that may not fit in the remaining frame period from being initiated. This bit controls whether the preSOF time point is moved back so that the preSOF time is lengthened.
 - 0 Disabledefault
 - 1 Enable (PreSOF time lengthened)
 - 0 **Issue Nonzero Bad CRC Code on FIFO Underrun**
A FIFO underrun occurs when there is no data in the FIFO to supply data transmission. When this occurs, the south bridge invalidates the data by sending an incorrect CRC code to the device. This bit controls the type of incorrect CRC sent.
 - 0 Non zero CRC (recommended).....default
 - 1 All zero CRC
 This option isn't really needed any more as non-zero CRC always works.

Offset 49 – MIA Analog Control.....RW

- 7-3 **Reserved** always reads 0
- 2 **Reserved (Do Not Program)**..... default = 0
- 1-0 **Port Slew Rate Control**
This field controls the slew rate of signals from the port. The voltage values are Pn+ and Pn- crossover-point voltages. The different crossover points are generated by controlling the rising edge of both Pn+ and Pn- signals.
 - 00 1.50Vdefault
 - 01 1.65V
 - 10 1.80V
 - 11 1.95V

Offset 60 - Serial Bus Release Number.....RO

- 7-0 **Release Number** always reads 10h

Offset 83-80 – PM Capability.....RO

- 31-0 **PM Capability** always reads 00020001h

Offset 84 – PM Capability StatusRW

- 7-0 **PM Capability Status**
 - 00 D0default
 - 11 D3 Hot

Offset C1-C0 - Legacy Support.....RO

- 15-0 **UHCI v1.1 Compliant**..... always reads 2000h

USB I/O Registers

These registers are compliant with the UHCI v1.1 standard. Refer to the UHCI v1.1 specification for further details.

I/O Offset 1-0 - USB Command

I/O Offset 3-2 - USB Status

I/O Offset 5-4 - USB Interrupt Enable

I/O Offset 7-6 - Frame Number

I/O Offset B-8 - Frame List Base Address

I/O Offset 0C - Start Of Frame Modify

I/O Offset 11-10 - Port 0 Status / Control

I/O Offset 13-12 - Port 1 Status / Control

Device 17 Function 5 Registers - AC97 Audio Controller

The audio controller interface is hardware compatible with AC97. The PCI configuration registers for the audio controller are located in the function 5 PCI configuration space of the VT8233A. The I/O registers are located in the system I/O space.

PCI Configuration Space Header

Offset 1-0 - Vendor ID.....RO

7-0 Vendor ID (1106h = VIA Technologies)

Offset 3-2 - Device ID.....RO

7-0 Device ID (3059h = VT8233A Audio Controller)

Offset 5-4 - Command.....RW

- 15-10 Reserved always reads 0
- 9 Reserved (fast back-to-back) fixed at 0
- 8 SERR# Enable..... fixed at 0
- 7 Reserved (address stepping) fixed at 0
- 6 Reserved (parity error response)..... fixed at 0
- 5 Reserved (VGA palette snoop)..... fixed at 0
- 4 Reserved (memory write and invalidate)..... fixed at 0
- 3 Reserved (special cycle monitoring)..... fixed at 0
- 2 Bus Master fixed at 0
- 1 Memory Space..... fixed at 0
- 0 I/O Space default=0 (disabled)

Offset 7-6 - Status.....RO

- 15 Detected Parity Error fixed at 0
- 14 Signalled System Error fixed at 0
- 13 Received Master Abort..... fixed at 0
- 12 Received Target Abort fixed at 0
- 11 Signalled Target Abort..... fixed at 0
- 10-9 DEVSEL# Timing
 - 00 Fast
 - 01 Medium..... fixed
 - 10 Slow
 - 11 Reserved
- 8 Data Parity Error fixed at 0
- 7 Fast Back-to-Back Capable..... fixed at 0
- 6-5 Reserved always reads 0
- 4 PM 1.1 fixed at 1
- 3-0 Reserved always reads 0

Offset 8 - Revision ID (40h).....RO

7-0 Silicon Revision Code

Offset 9 - Programming Interface (00h).....RO

Offset A - Sub Class Code (01h=Audio Device)RO

Offset B - Base Class Code (04h=Multimedia Device).....RO

Offset 13-10 - Base Address 0 – SGD Control / Status.. RW

- 31-16 Reserved always reads 0
- 15-8 Base Address..... default = 00h
- 7-0 00000001b (256 bytes)

Device 0 Offset 2D-2C – Subsystem Vendor ID (0000h)*RO

- 15-0 Subsystem Vendor ID default = 0
- *This register is RW if function 5-6 Rx44[4] = 1

Device 0 Offset 2F-2E – Subsystem ID (0000h)..... *RO

- 15-0 Subsystem ID default = 0
- *This register is RW if function 5-6 Rx44[4] = 1

Offset 34 – Capture Pointer (C0h)..... RO

Offset 3C - Interrupt Line RW

- 7-4 Reserved always reads 0
- 3-0 Audio Interrupt Routing
 - 0000 Disabled..... default
 - 0001 IRQ1
 - 0010 Reserved
 - 0011 IRQ3
 - 0100 IRQ4
 - 0101 IRQ5
 - 0110 IRQ6
 - 0111 IRQ7
 - 1000 IRQ8
 - 1001 IRQ9
 - 1010 IRQ10
 - 1011 IRQ11
 - 1100 IRQ12
 - 1101 IRQ13
 - 1110 IRQ14
 - 1111 Disabled

Offset 3D - Interrupt Pin (03h)..... RO

Offset 3E - Minimum Grant (00h)..... RO

Offset 3F - Maximum Latency (00h)..... RO

Audio-Specific PCI Configuration Registers

Offset 40 – AC Link Interface StatusRO

- 7-6 **Reserved** always reads 0
- 5 **Codec CID=11b Ready StatusRO**
 - 0 Codec Not Ready
 - 1 Codec Ready (audio ctrlr can access codec)
- 4 **Codec CID=10b Ready StatusRO**
 - 0 Codec Not Ready
 - 1 Codec Ready (audio ctrlr can access codec)
- 3 **Reserved** always reads 0
- 2 **Codec CID=01b Ready StatusRO**
 - 0 Codec Not Ready
 - 1 Codec Ready (audio ctrlr can access codec)
- 1 **AC97 Low-Power StatusRO**
 - 0 AC97 Codecs not in low-power mode
 - 1 AC97 Codecs in low-power mode
This bit reports 1 when Rx26[4] of the codecs is 1. It is used to determine whether the bit-clock should be gated.
- 0 **Codec CID=00b Ready StatusRO**
 - 0 Codec Not Ready
 - 1 Codec Ready (audio ctrlr can access codec)

Offset 41 – AC Link Interface Control..... RW

- 7 **AC-Link Interface**
 - 0 Disable..... default
 - 1 Enable
- 6 **AC-Link Reset**
 - 0 Assert AC-Link Reset (used for cold reset) def
 - 1 De-assert AC-Link Reset
- 5 **AC-Link Sync**
 - 0 Release SYNC..... default
 - 1 Force SYNC High (used for warm reset)
- 4 **AC-Link Serial Data Out**
 - 0 Release SDO default
 - 1 Force SDO High
- 3 **Variable-Sample-Rate On-Demand Mode**
 - 0 Disable (AC Link sends data every frame).. def
 - 1 Enable (AC Link sends data only when there is a request from the codec)
- 2 **AC Link SGD Read Channel PCM Data Output (8233A Only)**
 - 0 Disable..... default
 - 1 Enable

(Bit-2 is “3D Audio Channel Slots 3/4” in 8233)
- 1-0 **Reserved**always reads 0

Offset 42 – Function Enable.....RW

- 7-6 **Reserved** always reads 0
- 5 **Function 5 Config Reg Rx2C Writable.....RW**
 - 0 Device 17 Function 5 Rx2C-2F RO.....default
 - 1 Device 17 Function 5 Rx2C-2F RW
- 4-0 **Reserved** always reads 0

Offset 44 – MC97 Interface Control.....RO

Mapped RO to function 5 (RW in func 6) for status reporting.

- 7 **AC-Link Interface for Slot-5 (Modem).....RO**
 - 0 Disabledefault
 - 1 Enable
- 6 **Secondary Codec Support.....RO**
 - 0 Disabledefault
 - 1 Enable
- 5 **Function 6 Config Reg Rx9-B Writable.....RO**
 - 0 Device 17 Function 6 Rx9-B ROdefault
 - 1 Device 17 Function 6 Rx9-B RW
- 4 **Function 6 Config Reg 2Ch Writable.....RO**
 - 0 Device 17 Function 6 Rx2C-2F RO.....default
 - 1 Device 17 Function 6 Rx2C-2F RW
- 3 **SyncRO**
 This bit reports whether there is activity in function 6 (modem). When function 5 (audio) enters low-power state and wants to gate bit-clock, software needs to check this bit to see whether bit-clock can actually be gated, as function 6 shares the same bit-clock.
 - 0 Function 6 activity in progress that requires bit-clock
 - 1 Function 6 does not need bit-clock so bit-clock can be gated
- 2-0 **Reserved** always reads 0

Offset 48 – Volume Change Rate Control..... RW

- 7-4 **Reserved**always reads 0
 (Bits 7-4 are Volume Change Rate in 8233/8233C)
- 3 **Sync**
 This bit reports whether there is activity in function 5 (audio). When function 6 (modem) enters low-power state and wants to gate bit-clock, software needs to check this bit to see whether bit-clock can actually be gated, as function 5 shares the same bit-clock.
 - 0 Function 5 activity in progress that requires bit-clock
 - 1 Function 5 does not need bit-clock so bit-clock can be gated
- 2-0 **Reserved** RW

Offset 49 – S/PDIF Control..... RW

- 7-4 **Reserved** always reads 0
- 3 **DX3 (DirectSound) Channel S/PDIF Support**
 This bit controls whether DirectSound Channel 3 is used as S/PDIF support
 - 0 Disable..... default
 - 1 Enable
- 2 **Reserved**always reads 0
- 1-0 **S/PDIF Data Slot Select**
 - 00 Slot 10/11 default
 - 01 Slot 3/4
 - 10 Slot 7/8
 - 11 Slot 6/9

Offset C3-C0 – Power Mgmt Capability RO

- 31-0 **Power Mgmt Capability** ...always reads 0002 0001h

Offset C7-C4 – Power State..... RW

- 31-2 **Reserved**always reads 0
- 1-0 **Power State (D3 / D0 Only)**

I/O Base 0 Regs – Audio Scatter / Gather DMA

VT8233 and VT8233C have channels 0-3 at offsets 00-3F.

I/O Offset 30 – DXS Channel 3 SGD Status RWC

- 7 SGD ActiveRO**
 - 0 SGD has completed or been terminated.default
 - 1 SGD Active
- 6-5 Reserved always reads 0**
- 4 Current SGD Index Equals Stop IndexRO**
 - 0 SGD index not equal to stop indexdefault
 - 1 SGD index being processed equals the stop index. This bit differs from bit-2 of this register in that this bit becomes 1 as soon as the SGD *reaches* the index equal to the stop index. Bit-2 becomes 1 after the SGD *finishes* processing the index equal to the stop index. So this bit will always turn on before bit-2.
- 3 SGD Trigger Queued.....RO**

This bit reports whether the trigger used to restart the SGD operation is queued (I/O Offset 31[1] = 1 while the SGD engine is running).

 - 0 SGD trigger not queueddefault
 - 1 SGD trigger queued (when SGD reaches EOL, it will restart).
- 2 SGD Stop Interrupt Status..... RWC**
 - 1 SGD finished the index equal to the stop index set in 3B-38[31-24].
- 1 SGD EOL (End Of Link) RWC**
 - 1 Block is the last of the link. May be used by software as a signal to generate an interrupt request if I/O Offset 31[1] = 1.
- 0 SGD Flag RWC**
 - 1 Block complete. May be used by software as a signal to generate an interrupt request if I/O Offset 31[0] = 1.

I/O Offset 31 – DXS Channel 3 SGD Control RW

- 7 SGD Start WO (always reads 0)**
 - 0 No effect
 - 1 Start SGD operation
- 6 SGD Terminate WO (always reads 0)**
 - 0 No effect
 - 1 Terminate SGD operation
- 5 SGD Auto-Start**
 - 0 Stop at EOL default
 - 1 Auto Restart at EOL
- 4 Reservedalways reads 0**
- 3 SGD Pause**
 - 0 Release pause and resume the transfer
 - 1 Pause SGD read operation (SGD pointer stays at the current address). SGD will finish transferring the current block before pausing.
- 2 Interrupt on Stop Index = Current Index and End of Block**

Controls whether an interrupt is generated when the current index equals the stop index (30[2] = 1).

 - 0 Disable..... default
 - 1 Enable
- 1 Interrupt on EOL @ End of Block**

Controls whether an interrupt is generated on EOL (30[1] = 1).

 - 0 Disable..... default
 - 1 Enable
- 0 Interrupt on FLAG @ End-of-Block**

Controls whether an interrupt is generated on FLAG (30[0] = 1).

 - 0 Disable..... default
 - 1 Enable

I/O Offset 32 – Reserved..... always reads 0
I/O Offset 33 – Reserved..... always reads 0
 (Offsets 32 and 33 are DXS Channel Left & Right Volume in VT8233 and VT8233C)

I/O Offset 37-34 – DXS Chan 3 SGD Table Ptr Base.....RW
31-0 SGD Table Pointer Base Address (even addr) ... W
 Current Pointer Address..... R

I/O Offset 3B-38 – StopIndex / DataType / SampleRateRW
31-24 SGD Stop Index Setting..... default = FFh
23-22 Reserved always reads 0
21-20 PCM Format
 Selects the format used by the controller to process the incoming sample.
 00 8-bit Monodefault
 01 8-bit Stereo
 10 16-bit Mono
 11 16-bit Stereo
19-0 Reserved always reads 0
 (Bits 19-0 are Sample Rate in VT8233 and 8233C)

I/O Offset 3F-3C – DXS Chan 3 SGD Current Count ... RO

31-24 **Current SGD Index**
 This field reports the index the SGD engine is currently processing.
23-0 **Current SGD Count**
 This field reports the count remaining in the current entry being processed. For example, if 10 bytes of a 30-byte count have been transferred, this field would read 20 to indicate 20 bytes remaining.

Audio SGD Table Format

<u>63</u>	<u>62</u>	<u>61-56</u>	<u>55-32</u>	<u>31-0</u>
EOL	FLAG	-reserved-	Base Count [23:0]	Base Address [31:0]

EOL End Of Link. 1 indicates this block is the last of the link. If the channel “Interrupt on EOL” bit is set, then an interrupt is generated at the end of the transfer.
FLAG Block Flag. If set, transfer pauses at the end of this block. If the channel “Interrupt on FLAG” bit is set, then an interrupt is generated at the end of this block.

Multichannel SGD Registers

I/O Offset 40 – Multichannel SGD Status.....RWC

- 7 **SGD Active**RO
 - 0 SGD has completed or been terminated. default
 - 1 SGD Active
- 6-5 **Reserved** always reads 0
- 4 **Current SGD Index Equals Stop Index**RO
 - 0 SGD index not equal to stop index default
 - 1 SGD index being processed equals the stop index. This bit differs from bit-2 of this register in that this bit becomes 1 as soon as the SGD *reaches* the index equal to the stop index. Bit-2 becomes 1 after the SGD *finishes processing* the index equal to the stop index. So this bit will always turn on before bit-2.
- 3 **SGD Trigger Queued.....**RO

This bit reports whether the trigger used to restart the SGD operation is queued (I/O Offset 41[1] = 1 while the SGD engine is running).

 - 0 SGD trigger not queued default
 - 1 SGD trigger queued (when SGD reaches EOL, it will restart).
- 2 **SGD Stop Interrupt Status.....**RWC
 - 1 SGD finished the index equal to the stop index set in 4B-48[31-24].
- 1 **SGD EOL (End Of Link)**RWC
 - 1 Block is the last of the link. May be used by software as a signal to generate an interrupt request if I/O Offset 41[1] = 1.
- 0 **SGD Flag**RWC
 - 1 Block complete. May be used by software as a signal to generate an interrupt request if I/O Offset 41[0] = 1.

I/O Offset 41 – Multichannel SGD Control..... RW

- 7 **SGD Start**WO (always reads 0)
 - 0 No effect
 - 1 Start SGD operation
- 6 **SGD Terminate**WO (always reads 0)
 - 0 No effect
 - 1 Terminate SGD operation
- 5 **SGD Auto-Start**
 - 0 Stop at EOL default
 - 1 Auto Restart at EOL
- 4 **Reserved** always reads 0
- 3 **SGD Pause**
 - 0 Release pause and resume the transfer
 - 1 Pause SGD read operation (SGD pointer stays at the current address). SGD will finish transferring the current block before pausing.
- 2 **Interrupt on Stop Index = Current Index and End of Block**

Controls whether an interrupt is generated when the current index equals the stop index (40[2] = 1).

 - 0 Disable..... default
 - 1 Enable
- 1 **Interrupt on EOL @ End of Block**

Controls whether an interrupt is generated on EOL (40[1] = 1).

 - 0 Disable..... default
 - 1 Enable
- 0 **Interrupt on FLAG @ End-of-Block**

Controls whether an interrupt is generated on FLAG (40[0] = 1).

 - 0 Disable..... default
 - 1 Enable

I/O Offset 42 – Multichannel SGD Format.....RW

- 7 PCM Format**
Selects the PCM format used by the controller to process the incoming sample.
 - 0 8-bitdefault
 - 1 16-bit
- 6-4 # of Channels**
 - 000 -reserved-default
 - 001 One Channel
 - 010 Two Channels
 - 011 -reserved- (Three Channels in VT8233/8233C)
 - 100 Four Channels
 - 101 -reserved- (Five Channels in VT8233/8233C)
 - 110 Six Channels
 - 111 -reserved-
- 3-0 Reserved** always reads 0

I/O Offset 43 – Multichannel Scratch Register.....RW

- 7-0 No Hardware Function**..... default = 00h

I/O Offset 47-44 – Multichannel SGD Table Ptr Base...RW

- 31-0 SGD Table Pointer Base Address (even addr)W**
Current Pointer Address.....R

I/O Offset 4B-48 – Multichannel SGD Stop Index..... RW

- 31-24 SGD Stop Index Setting**default = FFh
- 23-0 Reserved**always reads 0
(Bits 0-23 are SGD Slot Select in VT8233/8233C)

I/O Offset 4F-4C – Multichannel SGD Current Count.. RO

- 31-24 Current SGD Index**
This field reports the index the SGD engine is currently processing.
- 23-0 Current SGD Count**
This field reports the count remaining in the current entry being processed. For example, if 10 bytes of a 30-byte count have been transferred, this field would read 20 to indicate 20 bytes remaining.

Write Channel 0 SGD Registers

I/O Offset 60 – Write Channel 0 SGD Status RWC

- 7 SGD ActiveRO**
0 SGD has completed or been terminated. default
1 SGD Active
- 6 SGD Paused.....RO**
0 SGD not pauseddefault
1 SGD Paused
- 5 Reserved always reads 0**
- 4 Current SGD Index Equals Stop IndexRO**
0 SGD index not equal to stop indexdefault
1 SGD index being processed equals the stop index. This bit differs from bit-2 of this register in that this bit becomes 1 as soon as the SGD *reaches* the index equal to the stop index. Bit-2 becomes 1 after the SGD *finishes processing* the index equal to the stop index. So this bit will always turn on before bit-2.
- 3 SGD Trigger Queued.....RO**
This bit reports whether the trigger used to restart the SGD operation is queued (I/O Offset 61[1] = 1 while the SGD engine is running).
0 SGD trigger not queueddefault
1 SGD trigger queued (when SGD reaches EOL, it will restart).
- 2 SGD Stop Interrupt Status..... RWC**
1 SGD finished the index equal to the stop index set in 6B-68[31-24].
- 1 SGD EOL (End Of Link) RWC**
1 Block is the last of the link. May be used by software as a signal to generate an interrupt request if I/O Offset 61[1] = 1.
- 0 SGD Flag RWC**
1 Block complete. May be used by software as a signal to generate an interrupt request if I/O Offset 61[0] = 1.

I/O Offset 61 – Write Channel 0 SGD Control..... RW

- 7 SGD Start WO (always reads 0)**
0 No effect
1 Start SGD operation
- 6 SGD Terminate WO (always reads 0)**
0 No effect
1 Terminate SGD operation
- 5 SGD Auto-Start**
0 Stop at EOL default
1 Auto Restart at EOL
- 4 Reserved always reads 0**
- 3 SGD Pause**
0 Release pause and resume the transfer
1 Pause SGD read operation (SGD pointer stays at the current address). SGD will finish transferring the current block before pausing.
- 2 Interrupt on Stop Index = Current Index and End of Block**
Controls whether an interrupt is generated when the current index equals the stop index (60[2] = 1).
0 Disable..... default
1 Enable
- 1 Interrupt on EOL @ End of Block**
Controls whether an interrupt is generated on EOL (60[1] = 1).
0 Disable..... default
1 Enable
- 0 Interrupt on FLAG @ End-of-Block**
Controls whether an interrupt is generated on FLAG (60[0] = 1).
0 Disable..... default
1 Enable

I/O Offset 62 – Write Channel 0 SGD FormatRW

- 7 **Reserved (Do Not Program)**.....always write 0
- 6 **Recording FIFO**
 - 0 Disabledefault
 - 1 Enable
- 5-0 **Reserved** always reads 0

I/O Offset 63 – Write Channel 0 Input Select.....RW

- 7-3 **Reserved** always reads 0
- 2 **Input Source Select**
 - 0 Line In (Slot 3, 4).....default
 - 1 Mic In (Slot 6)
- 1-0 **Recording Source Select**
 - 00 Primary Codexdefault
 - 01 Secondary Codec 01
 - 10 Secondary Codec 10
 - 11 Secondary Codec 11

I/O Offset 67-64 – Wr Channel 0 SGD Table Ptr Base..RW

- 31-0 **SGD Table Pointer Base Address (even addr)W**
- Current Pointer Address.....R**

I/O Offset 6B-68 – Write Channel 0 SGD Stop Index ... RW

- 31-24 **SGD Stop Index Setting**.....default = FFh
- 23-22 **Reserved**always reads 0
- 21-20 **PCM Format**
 - Selects the PCM format used by the controller to process the incoming sample.
 - 00 8-bit Mono..... default
 - 01 8-bit Stereo
 - 10 16-bit Mono
 - 11 16-bit Stereo
- 19-16 **Reserved** RW
- 15-0 **Reserved**always reads 0

I/O Offset 6F-6C – Wr Channel 0 SGD Current Count RO

- 31-24 **Current SGD Index**
 - This field reports the index the SGD engine is currently processing.
- 23-0 **Current SGD Count**
 - This field reports the count remaining in the current entry being processed. For example, if 10 bytes of a 30-byte count have been transferred, this field would read 20 to indicate 20 bytes remaining.

I/O Offset 70-7F – Reservedalways reads 0
(Offsets 70-7F are Write Channel 1 in 8233/8233C)

Codec Command / Status SGD Registers

These registers are used to send commands to the codecs

I/O Offset 83-80 – AC97 Controller Cmd (W) / Status (R)

This register may be accessed from either function 5 or 6

- 31-30 Codec ID** RW
 - 00 Select Codec CID = 00
 - 01 Select Codec CID = 01
 - 10 Select Codec CID = 10
 - 11 Select Codec CID = 11
- 29 Codec 11 Data / Status / Index Valid**..... RO
 - 0 Not Valid
 - 1 Valid (OK to Read bits 0-23)
- 28 Codec 10 Data / Status / Index Valid**..... RO
 - 0 Not Valid
 - 1 Valid (OK to Read bits 0-23)
- 27 Codec 01 Data / Status / Index Valid**..... RO
 - 0 Not Valid
 - 1 Valid (OK to Read bits 0-23)
- 26 Reserved** always reads 0
- 25 Codec 00 Data / Status / Index Valid**..... RO
 - 0 Not Valid
 - 1 Valid (OK to Read bits 0-23)
- 24 AC97 Controller Busy** RO
 - 0 Codec is ready for a register access command
 - 1 AC97 Controller is sending a command to the codec (commands are not accepted)
- 23 Codec Register Read / Write Mode**..... RW
 - 0 Select Codec register write mode
 - 1 Select Codec register read mode
- 22-16 Codec Register Index [7:1]**.....RW

Index of the AC97 codec register to access (in the attached codec). Data must be written before or at the same time as Index because writing to the index triggers the AC97 controller to access the addressed codec register over the AC-link interface.
- 15-0 Codec Register Data** RW

I/O Offset 87-84 – SGD Status Shadow RO

- 31-28 Reserved** (Audio Record 1 in 8233/8233C). always 0
- 27 Audio Record 0 SGD Active Shadow** (Rx60[7])
- 26 Audio Record 0 SGD Stop Shadow** (Rx60[2])
- 25 Audio Record 0 SGD EOL Shadow**..... (Rx60[1])
- 24 Audio Record 0 SGD Flag Shadow**..... (Rx60[0])
- 23-20 Reserved**always reads 0
- 19 MultiChannel SGD Active Shadow** (Rx40[7])
- 18 MultiChannel SGD Stop Shadow** (Rx40[2])
- 17 MultiChannel SGD EOL Shadow**..... (Rx40[1])
- 16 MultiChannel SGD Flag Shadow**..... (Rx40[0])
- 15 DX Channel 3 SGD Active Shadow** (Rx30[7])
- 14 DX Channel 3 SGD Stop Shadow** (Rx30[2])
- 13 DX Channel 3 SGD EOL Shadow** (Rx30[1])
- 12 DX Channel 3 SGD Flag Shadow** (Rx30[0])
- 11-0 Reserved** (DXS Chan 0-2 in 8233/8233C)... always 0

I/O Offset 8B-88 – Codec GPI Interrupt Status / GPIO RO

This register may be accessed from either function 5 or 6

- 31-16 GPI Interrupt Status**..... RO
 - R GPI[15-0] Interrupt Status
 - W 1 to clear
- 15-0 Codec GPIO**..... RO
 - R Reflect status of Codec GPI[15-0]
 - W Triggers AC-Link slot-12 output to codec

I/O Offset 8F-8C – Codec GPI Interrupt Enable..... RO

This register may be accessed from either function 5 or 6

- 31-16 Interrupt on GPI[15-0] Change of Status** RO
 - 0 Disable
 - 1 Enable
- 15-0 Reserved**always reads 0

Offset 90-9F – Mapped from Function 5/6 Rx40-4F RO

Device 17 Function 6 Registers - AC97 Modem Controller

The modem controller interface is hardware compatible with AC97. The PCI configuration registers for the modem controller are located in the function 6 PCI configuration space of the VT8233A. The I/O registers are located in the system I/O space.

PCI Configuration Space Header

Offset 1-0 - Vendor ID.....RO

7-0 Vendor ID (1106h = VIA Technologies)

Offset 3-2 - Device ID.....RO

7-0 Device ID (3068h = VT8233A Modem Controller)

Offset 5-4 – Command.....RW

- 15-10 Reserved always reads 0
- 9 Reserved (fast back-to-back) fixed at 0
- 8 SERR# Enable..... fixed at 0
- 7 Reserved (address stepping) fixed at 0
- 6 Reserved (parity error response)..... fixed at 0
- 5 Reserved (VGA palette snoop)..... fixed at 0
- 4 Reserved (memory write and invalidate)..... fixed at 0
- 3 Reserved (special cycle monitoring)..... fixed at 0
- 2 Bus Master fixed at 0
- 1 Memory Space..... fixed at 0
- 0 I/O Space default=0 (disabled)

Offset 7-6 - Status (0200h).....RO

- 15 Detected Parity Error always reads 0
- 14 Signalled System Error fixed at 0
- 13 Received Master Abort..... fixed at 0
- 12 Received Target Abort fixed at 0
- 11 Signalled Target Abort..... fixed at 0
- 10-9 DEVSEL# Timing
 - 00 Fast
 - 01 Medium..... fixed
 - 10 Slow
 - 11 Reserved
- 8 Data Parity Error fixed at 0
- 7 Fast Back-to-Back Capable..... fixed at 0
- 6-0 Reserved always reads 0

Offset 8 - Revision ID (78h).....RO

7-0 Silicon Revision Code

Offset 9 - Programming Interface (00h).....*RO

Offset A - Sub Class Code (80h).....*RO

Offset B - Base Class Code (07h).....*RO

*Registers 9-B are RW if function 5-6 Rx44[5] = 1

Offset 13-10 - Base Address 0 – SGD Control / Status.. RW

- 31-16 Reserved always reads 0
- 15-8 Base Address..... default = 00h
- 7-0 00000001b (256 bytes)

Device 0 Offset 2D-2C – Subsystem Vendor ID (0000h)*RO

15-0 Subsystem Vendor ID default = 0
*This register is RW if function 5-6 Rx44[4] = 1

Device 0 Offset 2F-2E – Subsystem ID (0000h).....*RO

15-0 Subsystem ID default = 0
*This register is RW if function 5-6 Rx44[4] = 1

Offset 3C - Interrupt Line RW

- 7-4 Reserved always reads 0
- 3-0 Modem Interrupt Routing
 - 0000 Disabled..... default
 - 0001 IRQ1
 - 0010 Reserved
 - 0011 IRQ3
 - 0100 IRQ4
 - 0101 IRQ5
 - 0110 IRQ6
 - 0111 IRQ7
 - 1000 IRQ8
 - 1001 IRQ9
 - 1010 IRQ10
 - 1011 IRQ11
 - 1100 IRQ12
 - 1101 IRQ13
 - 1110 IRQ14
 - 1111 Disabled

Offset 3D - Interrupt Pin (03h).....RO

Offset 3E - Minimum Grant (00h).....RO

Offset 3F - Maximum Latency (00h).....RO

Modem-Specific PCI Configuration Registers

Offset 40 – AC Link Interface StatusRO

- 7-6 **Reserved** always reads 0
- 5 **Codec CID=11b Ready StatusRO**
 - 0 Codec Not Ready
 - 1 Codec Ready (modem ctrlr can access codec)
- 4 **Codec CID=10b Ready StatusRO**
 - 0 Codec Not Ready
 - 1 Codec Ready (modem ctrlr can access codec)
- 3 **Reserved** always reads 0
- 2 **Codec CID=01b Ready StatusRO**
 - 0 Codec Not Ready
 - 1 Codec Ready (modem ctrlr can access codec)
- 1 **AC97 Low-Power StatusRO**
 - 0 AC97 Codecs not in low-power mode
 - 1 AC97 Codecs in low-power mode

This bit reports 1 when Rx26[4] of the codecs is 1. It is used to determine whether the bit-clock should be gated.
- 0 **Codec CID=00b Ready StatusRO**
 - 0 Codec Not Ready
 - 1 Codec Ready (modem ctrlr can access codec)

Offset 41 – AC Link Interface Control..... RW

- 7 **AC-Link Interface**
 - 0 Disable..... default
 - 1 Enable
- 6 **AC-Link Reset**
 - 0 Assert AC-Link Reset (used for cold reset) def
 - 1 De-assert AC-Link Reset
- 5 **AC-Link Sync**
 - 0 Release SYNC..... default
 - 1 Force SYNC High (used for warm reset)
- 4 **AC-Link Serial Data Out**
 - 0 Release SDO default
 - 1 Force SDO High
- 3 **Variable-Sample-Rate On-Demand Mode..... RO**

This bit is controlled through function 5 but may be read from function 6.

 - 0 Disable (AC Link sends data every frame).. def
 - 1 Enable (AC Link sends data only when there is a request from the codec)
- 2 **AC Link SGD Read Chan PCM Data Output (8233A Only)..... RO**

(Bit-2 is "3D Audio Channel Slots 3/4" in 8233)

 - 0 Disable..... default
 - 1 Enable
- 1-0 **Reserved**always reads 0

Offset 42 – Function Enable.....RO

This register is controlled through function 5 but may be read from function 6.

- 7-6 **Reserved** always reads 0
- 5 **Function 5 Config Reg Rx2C Writable.....RO**
 - 0 Device 17 Function 5 Rx2C-2F RO.....default
 - 1 Device 17 Function 5 Rx2C-2F RW
- 4-0 **Reserved** always reads 0

Offset 44 – MC97 Interface Control.....RW

- 7 **AC-Link Interface for Slot-5 (Modem)**
 - 0 Disabledefault
 - 1 Enable
- 6 **Secondary Codec Support**
 - 0 Disabledefault
 - 1 Enable
- 5 **Function 6 Config Reg Rx9-B Writable**
 - 0 Device 17 Function 6 Rx9-B ROdefault
 - 1 Device 17 Function 6 Rx9-B RW
- 4 **Function 6 Config Reg 2Ch Writable**
 - 0 Device 17 Function 6 Rx2C-2F RO.....default
 - 1 Device 17 Function 6 Rx2C-2F RW
- 3 **Sync**

This bit reports whether there is activity in function 6 (modem). When function 5 (audio) enters low-power state and wants to gate bit-clock, software needs to check this bit to see whether bit-clock can actually be gated, as function 6 shares the same bit-clock.

 - 0 Function 6 activity in progress that requires bit-clock
 - 1 Function 6 does not need bit-clock so bit-clock can be gated
- 2-0 **Reserved** always reads 0

Offset 48 – Volume Change Rate Control RO

This register is controlled through function 5 but may be read from function 6.

- 7-4 **Reserved** always reads 0
(Bits 7-4 are Volume Change Rate in 8233/8233C)
- 3 **Sync** **RO**

This bit reports whether there is activity in function 5 (audio). When function 6 (modem) enters low-power state and wants to gate bit-clock, software needs to check this bit to see whether bit-clock can actually be gated, as function 5 shares the same bit-clock.

 - 0 Function 5 activity in progress that requires bit-clock
 - 1 Function 5 does not need bit-clock so bit-clock can be gated
- 2-0 **Reserved** always reads 0

Offset 49 – S/PDIF Control..... RO

This register is controlled through function 5 but may be read from function 6.

- 7-4 **Reserved** **RO**
- 3 **DX3 (DirectSound) Channel S/PDIF Support.. RO**

This bit controls whether DirectSound Channel 3 is used as S/PDIF support

 - 0 Disable..... default
 - 1 Enable
- 2 **Reserved** **RO**
- 1-0 **S/PDIF Data Slot Select RO**
 - 00 Slot 10/11 default
 - 01 Slot 3/4
 - 10 Slot 7/8
 - 11 Slot 6/9

Offset D3-D0 – Power Mgmt Capability RO

- 31-0 **Power Mgmt Capability ...always reads 0002 0001h**

Offset D7-D4 – Power State..... RW

- 31-2 **Reserved** always reads 0
- 1-0 **Power State (D3 / D0 Only)**

I/O Base 0 Regs – Modem Scatter / Gather DMA

Modem SGD Read Channel Registers

I/O Offset 40 – Modem SGD Read Channel StatusRWC

- 7 **SGD Active**RO
 - 0 SGD has completed or been terminated. default
 - 1 SGD Active
- 6 **SGD Paused**.....RO
 - 0 SGD not pauseddefault
 - 1 SGD Paused
- 5-4 **Reserved** always reads 0
- 3 **SGD Trigger Queued**.....RO

This bit reports whether the trigger used to restart the SGD operation is queued (I/O Offset 41[1] = 1 while the SGD engine is running).

 - 0 SGD trigger not queueddefault
 - 1 SGD trigger queued (when SGD reaches EOL, it will restart).
- 2 **SGD Stop Interrupt Status**..... RWC
 - 1 SGD finished the index equal to the stop index set in 4B-48[31-24].
- 1 **SGD EOL (End Of Link)** RWC
 - 1 Block is the last of the link. May be used by software as a signal to generate an interrupt request if I/O Offset 41[1] = 1.
- 0 **SGD Flag** RWC
 - 1 Block complete. May be used by software as a signal to generate an interrupt request if I/O Offset 41[0] = 1.

I/O Offset 41 – Modem SGD Read Channel Control.....RW

- 7 **SGD Start** WO (always reads 0)
 - 0 No effect
 - 1 Start SGD read channel operation
- 6 **SGD Terminate**..... WO (always reads 0)
 - 0 No effect
 - 1 Terminate SGD read channel operation
- 5-4 **Test (Do Not Program)**.....always write 0
- 3 **SGD Pause** RW
 - 0 Release SGD read channel pause and resume the transfer from the paused line
 - 1 Pause SGD read channel operation (SGD read channel pointer stays at the current address)
- 2-0 **Reserved** always reads 0

I/O Offset 42 – Modem SGD Read Channel Type..... RW

- 7 **Auto-Start SGD at EOL**
 - 0 Stop at EOL default
 - 1 Auto restart at EOL
- 6-4 **Reserved**always reads 0
- 3-2 **Interrupt Select**

This bit determines the timing of interrupt generation when bit-1 or bit-0 of this register are equal to 1.

 - 00 Interrupt at PCI Read of Last Line default
 - 01 Interrupt at Last Sample Sent
 - 10 Interrupt at Less Than One Line to Send
 - 11 -reserved-
- 1 **Interrupt on EOL @ End of Block**
 - 0 Disable..... default
 - 1 Enable
- 0 **Interrupt on FLAG @ End-of-Blk**
 - 0 Disable..... default
 - 1 Enable

I/O Offset 47-44 – Modem SGD R Ch Table Ptr Base .. RW

- 31-0 **SGD Table Pointer Base Address (even addr).... W**
Current Pointer Address R

I/O Offset 4F-4C – Modem SGD R Ch Current Count.. RO

- 31-24 **Current Modem SGD Read Channel Index**

This field reports the index the SGD engine is currently processing.
- 23-0 **Current Modem SGD Read Channel Count**

This field reports the count remaining in the current entry being processed. For example, if 10 bytes of a 30-byte count have been transferred, this field would read 20 to indicate 20 bytes remaining.

Modem SGD Table Format

<u>63</u>	<u>62</u>	<u>61</u>	<u>60-56</u>	<u>55-32</u>	<u>31-0</u>
EOL	FLAG	STOP	-reserved-	Base	Base
				Count	Address
				[23:0]	[31:0]

Modem SGD Write Channel Registers

I/O Offset 50 – Modem SGD Write Channel StatusRO

- 7 **SGD Active**RO
 - 0 SGD has completed or been terminated. default
 - 1 SGD Active
- 6 **SGD Paused**.....RO
 - 0 SGD not pauseddefault
 - 1 SGD Paused
- 5-4 **Reserved** always reads 0
- 3 **SGD Trigger Queued**.....RO

This bit reports whether the trigger used to restart the SGD operation is queued (I/O Offset 51[1] = 1 while the SGD engine is running).

 - 0 SGD trigger not queueddefault
 - 1 SGD trigger queued (when SGD reaches EOL, it will restart).
- 2 **SGD Stop Interrupt Status**..... RWC
 - 1 SGD finished the index equal to the stop index set in 5B-58[31-24].
- 1 **SGD EOL (End Of Link)** RWC
 - 1 Block is the last of the link. May be used by software as a signal to generate an interrupt request if I/O Offset 51[1] = 1.
- 0 **SGD Flag** RWC
 - 1 Block complete. May be used by software as a signal to generate an interrupt request if I/O Offset 51[0] = 1.

I/O Offset 51 – Modem SGD Write Channel Control....RW

- 7 **SGD Start** WO (always reads 0)
 - 0 No effect
 - 1 Start SGD write channel operation
- 6 **SGD Terminate**..... WO (always reads 0)
 - 0 No effect
 - 1 Terminate SGD write channel operation
- 5-4 **Test (Do Not Program)**.....always write 0
- 3 **SGD Pause** RW
 - 0 Release SGD write channel pause and resume the transfer from the paused line
 - 1 Pause SGD write channel operation (SGD write channel pointer stays at current address)
- 2 **Reserved** always reads 0
- 1 **Reset Modem Write SGD Operation**RW
- 0 **Reserved** always reads 0

I/O Offset 52 – Modem SGD Write Channel Type..... RW

- 7 **Auto-Start SGD at EOL**
 - 0 Stop at EOL default
 - 1 Auto restart at EOL
- 6-2 **Reserved**always reads 0
- 1 **Interrupt on EOL @ End of Block**
 - 0 Disable..... default
 - 1 Enable
- 0 **Interrupt on FLAG @ End-of-Blk**
 - 0 Disable..... default
 - 1 Enable

I/O Offset 57-54 – Modem SGD W Ch Table Ptr Base. RW

- 31-0 **SGD Table Pointer Base Address (even addr).... W**
- Current Pointer Address** R

I/O Offset 5F-5C – Modem SGD W Ch Current Count RO

- 31-24 **Current Modem SGD Write Channel Index**

This field reports the index the SGD engine is currently processing.
- 23-0 **Current Modem SGD Write Channel Count**

This field reports the count remaining in the current entry being processed. For example, if 10 bytes of a 30-byte count have been transferred, this field would read 20 to indicate 20 bytes remaining.

- EOL** End Of Link. 1 indicates this block is the last of the link. If the channel “Interrupt on EOL” bit is set, then an interrupt is generated at the end of the transfer.
- FLAG** Block Flag. If set, transfer pauses at the end of this block. If the channel “Interrupt on FLAG” bit is set, then an interrupt is generated at the end of this block.
- STOP** Block Stop. If set, transfer pauses at the end of this block. To resume the transfer, write 1 to Rx?0[2].

Codec Command / Status SGD Registers

These registers are used to send commands to the codecs

Offset 83-80 – AC97 Controller Command (W) / Status (R)

This register may be accessed from either function 5 or 6

- 31-30 Codec ID** RW
 - 00 Select Codec CID = 00
 - 01 Select Codec CID = 01
 - 10 Select Codec CID = 10
 - 11 Select Codec CID = 11
- 29 Codec 11 Data / Status / Index Valid**..... RO
 - 0 Not Valid
 - 1 Valid (OK to Read bits 0-23)
- 28 Codec 10 Data / Status / Index Valid**..... RO
 - 0 Not Valid
 - 1 Valid (OK to Read bits 0-23)
- 27 Codec 01 Data / Status / Index Valid**..... RO
 - 0 Not Valid
 - 1 Valid (OK to Read bits 0-23)
- 26 Reserved** always reads 0
- 25 Codec 00 Data / Status / Index Valid**..... RO
 - 0 Not Valid
 - 1 Valid (OK to Read bits 0-23)
- 24 AC97 Controller Busy** RO
 - 0 Codec is ready for a register access command
 - 1 AC97 Controller is sending a command to the codec (commands are not accepted)
- 23 Codec Register Read / Write Mode**..... RW
 - 0 Select Codec register write mode
 - 1 Select Codec register read mode
- 22-16 Codec Register Index [7:1]**..... RW
Index of the AC97 codec register to access (in the attached codec). Data must be written before or at the same time as Index because writing to the index triggers the AC97 controller to access the addressed codec register over the AC-link interface.
- 15-0 Codec Register Data** RW

Offset 87-84 – Modem SGD Status Shadow RO

- 31-30 Reserved**always reads 0
- 29 Modem Write SGD Active Shadow** (Rx50[7])
- 28 Modem Read SGD Active Shadow** (Rx40[7])
- 27-26 Reserved**always reads 0
- 25 Modem Write SGD Stop Shadow** (Rx50[2])
- 24 Modem Read SGD Stop Shadow** (Rx40[2])
- 23-22 Reserved**always reads 0
- 21 Modem Write SGD EOL Shadow**..... (Rx50[1])
- 20 Modem Read SGD EOL Shadow**..... (Rx40[1])
- 19-18 Reserved**always reads 0
- 17 Modem Write SGD Flag Shadow** (Rx50[0])
- 16 Modem Read SGD Flag Shadow**..... (Rx40[0])
- 15-0 Reserved**always reads 0

Offset 8B-88 – Codec GPI Interrupt Status / GPIORWC

This register may be accessed from either function 5 or 6

- 31-16 GPI Interrupt Status**..... RWC
 - R GPI[15-0] Interrupt Status
 - W 1 to clear
- 15-0 Codec GPIO**.....RW
 - R Reflect status of Codec GPI[15-0]
 - W Triggers AC-Link slot-12 output to codec

Offset 8F-8C – Codec GPI Interrupt Enable RW

This register may be accessed from either function 5 or 6

- 31-16 Interrupt on GPI[15-0] Change of Status**RW
 - 0 Disable
 - 1 Enable
- 15-0 Reserved**always reads 0

Offset 90-9F – Mapped from Function 5/6 Rx40-4F RO

FUNCTIONAL DESCRIPTIONS

Power Management

Power Management Subsystem Overview

The power management function of the VT8233A is indicated in the following block diagram:

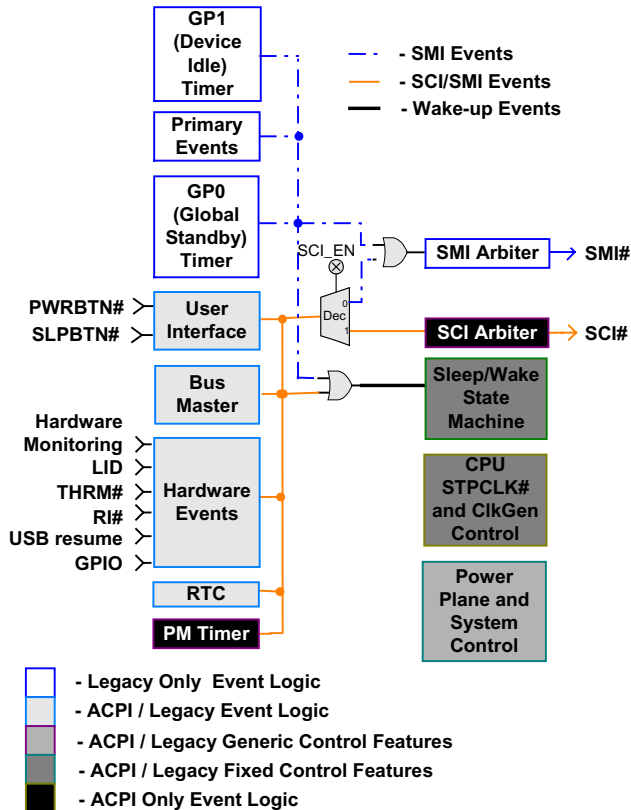

Figure 3. Power Management Subsystem Block Diagram

Refer to ACPI Specification v1.0 and APM specification v1.2 for additional information.

Processor Bus States

The VT8233A supports the complete set of C0 to C3 processor states as specified in the Advanced Configuration and Power Interface (ACPI) specification (and defined in ACPI I/O space Registers 10-15):

- C0: Normal Operation
- C1: CPU Halt (controlled by software).
- C2: Stop Clock. Entered when the Processor Level 2 register (PMIO Rx14) is read. The STPCLK# signal is asserted to put the processor in the Stop Grant State. The CPUSTP# signal is not asserted so that host clocks remain running. To exit this state, the chip negates STPCLK#.
- C3: Suspend. Entered when the Processor Level 3 register (PMIO Rx15) is read. In addition to STPCLK# assertion as in the C2 state, the SUSST1# (suspend status 1) signal is asserted to tell the north bridge to switch to "Suspend DRAM Refresh" mode based on the 32KHz suspend clock (SUSCLK) provided by the VT8233A. If the Host Stop bit is enabled, then CPUSTP# is also asserted to stop clock generation and put the CPU into Stop Clock State. To exit this state, the chip negates CPUSTP# and allows time for the processor PLL to lock. Then the SUSST1# and STPCLK# signals are negated to resume to normal operation.

During normal operation, two mechanisms are provided to modulate CPU execution and control power consumption by throttling the duty cycle of STPCLK#:

- a. Setting the Throttle Enable bit to 1, the duty cycle defined in Throttle Duty Cycle (PMIO Rx10) is used.
- b. THRM# pin assertion enables automatic clock throttling with duty cycle pre-configured in THRM# Duty Cycle (PCI configuration Rx4C).

System Suspend States and Power Plane Control

There are three power planes inside the VT8233A. The first power plane (VCCS) is always on unless turned off by the mechanical switch. The second power plane (VCC) is controlled by chip output SUSC# (also called “PSON”). The third plane (VCCRTC) is powered by the combination of the VCCS and the external battery (VBAT) for the integrated real time clock. Most of the circuitry inside the VT8233A is powered by VCC. The amount of logic powered by VCCS is very small; its main function is to control the supply of VCC and other power planes. VCCRTC is always on unless both the mechanical switch and VBAT are removed.

The VT8233A supports multiple system suspend states by configuring the Sleep Type field of PMIO Rx4-5:

- a) **POS (Power On Suspend):** Most devices in the system remain powered. The host bus is put into an equivalent of the C3 state. In particular, the CPU is put into the Stop Grant State or Stop Clock State depending on the setting of the Host Stop bit. SUSST1# is asserted to tell the north bridge to switch to “Suspend DRAM Refresh” mode based on the 32KHz SUSCLK provided by the VT8233A. As to the PCI bus, setting the PCLK Run bit to 0 enables the CLKRUN protocol defined in the PCI Mobile Design Guide. That is, the PCKRUN# pin will be de-activated after the PCI bus is idle for 26 clocks. Any PCI bus masters including the north bridge may resume PCI clock operation by pulling the PCKRUN# pin low. During the PCKRUN# de-activation period, the PCISTP# pin may be activated to disable the output of the PCI clock generator if the PCI Stop bit is enabled. When the system resumes from POS, the VT8233A can optionally resume without resetting the system, can reset the processor only, or can reset the entire system. When no reset is performed, the chip only needs to wait for the clock synthesizer and processor PLL to lock before the system is resumed, which typically takes 20ms.
- b) **STR (Suspend to RAM):** Power is removed from most of the system except the system DRAM. Power is supplied to the suspend refresh logic in the north bridge (e.g., VSUS25 of the VT8633) and the suspend logic of the VT8233A (VSUS33).
- c) **STD (Suspend to Disk, also called Soft-off):** Power is removed from most of the system except the suspend logic of VT8233A (VSUS33).
- d) **Mechanical Off:** This is not a suspend state. All power in the system is removed except the RTC battery.

The suspend state is entered by setting the Sleep Enable bit to 1. Three power plane control signals (SUSA#, SUSB# and SUSC#) are provided to turn off more system power planes as the system moves to deeper power-down states, i.e., from normal operation to POS (only SUSA# asserted), to STR (both SUSA# and SUSB# asserted), and to STD (all three SUS# signals asserted). In particular, the assertion of SUSC# can be used to turn off the VCC supply to the VT8233A.

One additional suspend status indicator (SUSST1#) is provided to inform the north bridge and the rest of the system of the processor and system suspend states. SUSST1# is asserted when the system enters the suspend state or the processor enters the C3 state. SUSST1# is connected to the north bridge to switch between normal and suspend-DRAM-refresh modes.

General Purpose I/O Ports

As ACPI compliant hardware, the VT8233A includes PWRBTN#, SLPBTN#, and RI# pins to implement power button, sleep button, and ring indicator functionality, respectively. Furthermore, the VT8233A offers many general-purpose I/O ports with the following capabilities:

- **I²C / SMB Support**
- **Thermal Detect**
- **Notebook Lid Open / Close Detect**
- **Battery Low Detect**
- **Twelve General Purpose Input Ports** (multiplexed with other functions).
- **Nineteen General Purpose Output Ports** (1 dedicated and 18 multiplexed with other functions)
- **Four General Purpose Input / Output Ports** (multiplexed with other functions)

In addition, the VT8233A provides an external dedicated SMI pin (EXTSMI#). The external SMI input can be programmed to trigger an SCI or SMI at both the rising and falling edges of the corresponding input signal. Software can check the status of the input pin and take appropriate actions.

Power Management Events

Three types of power management events are supported:

1) **ACPI-required Fixed Events** defined in the PM1a Status and PM1a Enable registers. These events can trigger either SCI or SMI depending on the SCI Enable bit:

- PWRBTN# Triggering
- RTC Alarm
- Sleep Button
- ACPI Power Management Timer Carry (always SCI)
- BIOS Release (always SCI)

2) **ACPI-aware General Purpose Function Events** defined in the GP Status and GP SCI Enable, and GP SMI Enable registers. These events can trigger either SCI or SMI depending on the setting of individual SMI and SCI enable bits:

- External SMI triggering
- USB Resume
- Ring Indicator (RI#)
- Battery Low Detect (BATLOW#)
- Notebook Lid Open/Close Detect (LID)
- Thermal Detect (THRM#)

3) **Generic Global Events** defined in the Global Status and Global Enable registers. These registers are mainly used for SMI:

- PCI Bus Clock Run Resume
- Primary Interrupt Occurance
- GP0 and GP1 Timer Time Out
- Secondary Event Timer Time Out
- Occurrence of Primary Events (defined in the Primary Activity Status and Primary Activity Enable registers)
- Legacy USB accesses (keyboard and mouse)
- Software SMI

System and Processor Resume Events

Depending on the system suspend state, different features can be enabled to resume the system. There are two classes of resume events:

- a) VSUS-based events. Event logic resides in the VSUS plane and thus can resume the system from any suspend state. Such events include PWRBTN#, RI#, BATLOW#, LID, SMBus resume event, RTC alarm, EXTSMI#, and GPI (EXTSMI1#).
- b) VCC-Based Events. Event logic resides in the VCC plane and thus can only resume the system from the POS state. Such events include the ACPI PM timer, USB resume, and EXTSMIn#.

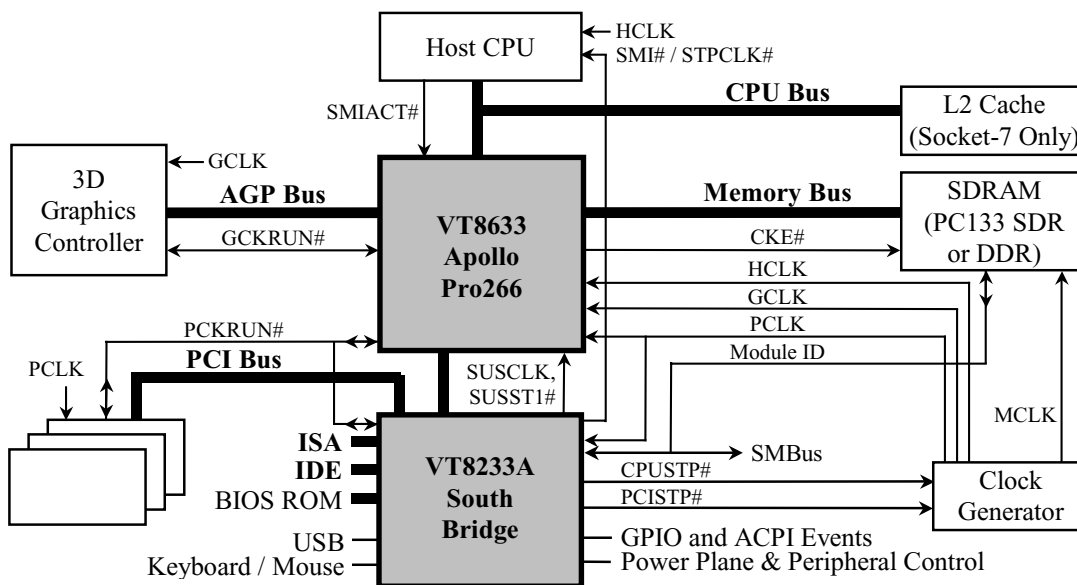

Figure 4. System Block Diagram Using the VT8633 North Bridge

Legacy Power Management Timers

In addition to the ACPI power management timer, the VT8233A includes the following four legacy power management timers:

- GP0 Timer:** general purpose timer with primary event
- GP1 Timer:** general purpose timer with peripheral event reload
- Secondary Event Timer:** to monitor secondary events
- Conserve Mode Timer:** Hardware-controlled return to standby

The normal sequence of operations for a general purpose timer (GP0 or GP1) is to

- 1) First program the time base and timer value of the initial count (register GP Timer Count).
- 2) Then activate counting by setting the GP0 Start or GP1 Start bit to one: the timer will start with the initial count and count down towards 0.
- 3) When the timer counts down to zero, an SMI will be generated if enabled (GP0 Timeout Enable and GP1 Timeout Enable in the Global Enable register) with status recorded (GP0 Timeout Status and GP1 Timeout Status in the Global Status register).
- 4) Each timer can also be programmed to reload the initial count and restart counting automatically after counting down to 0. This feature is not used in standard VIA BIOS.

The GP0 and GP1 timers can be used just as the general purpose timers described above. However, they can also be programmed to reload the initial count by system primary events or peripheral events thus used as primary event (global standby) timer and peripheral timer, respectively. The secondary event timer is solely used to monitor secondary events.

System Primary and Secondary Events

Primary system events are distinguished in the Primary Activity Status and Primary Activity Enable registers:

<u>Bit</u>	<u>Event</u>	<u>Trigger</u>
7	Keyboard Access	I/O port 60h
6	Serial Port Access	I/O ports 3F8h-3FFh, 2F8h-2FFh, 3E8h-3EFh, or 2E8h-2EFh
5	Parallel Port Access	I/O ports 378h-37Fh or 278h-27Fh
4	Video Access	I/O ports 3B0h-3DFh or memory A/B segments
3	IDE/Floppy Access	I/O ports 1F0h-1F7h, 170h-177h, or 3F5h
2	Reserved	
1	Primary Interrupts	Each channel of the interrupt controller can be programmed to be a primary or secondary interrupt
0	ISA Master/DMA Activity	

Each category can be enabled as a primary event by setting the corresponding bit of the Primary Activity Enable register to 1.

If enabled, the occurrence of the primary event reloads the GP0 timer if the Primary Activity GP0 Enable bit is also set to 1. The cause of the timer reload is recorded in the corresponding bit of Primary Activity Status register while the timer is reloaded. If no enabled primary event occurs during the count down, the GP0 timer will time out (count down to 0) and the system can be programmed (setting the GP0 Timeout Enable bit in the Global Enable register to one) to trigger an SMI to switch the system to a power down mode.

The VT8233A distinguishes two kinds of interrupt requests as far as power management is concerned: the primary and secondary interrupts. Like other primary events, the occurrence of a primary interrupt demands that the system be restored to full processing capability. Secondary interrupts, however, are typically used for housekeeping tasks in the background unnoticeable to the user. The VT8233A allows each channel of interrupt request to be declared as either primary, secondary, or ignorable in the Primary IRQ Channel and Secondary IRQ Channel registers. Secondary interrupts are the only system secondary events defined in the VT8233A.

Like primary events, primary interrupts can be made to reload the GP0 timer by setting the PIRQ Enable bit to 1. Secondary interrupts do not reload the GP0 timer. Therefore the GP0 timer will time out and the SMI routine can put the system into power down mode if no events other than secondary interrupts are happening periodically in the background.

Primary events can be programmed to trigger an SMI (setting of the Primary Activity Enable bit). Typically, this SMI triggering is turned off during normal system operation to avoid degrading system performance. Triggering is turned on by the SMI routine before entering the power down mode so that the system may be returned to normal operation at the occurrence of primary events. At the same time, the GP0 timer is reloaded and the count down process is restarted.

Peripheral Events

Primary and secondary events define system events in general and the response is typically expressed in terms of system events. Individual peripheral events can also be monitored by the VT8233A through the GP1 timer. The following four categories of peripheral events are distinguished (via the GP Reload Enable register):

- Bit-7 **Keyboard Access**
- Bit-6 **Serial Port Access**
- Bit-4 **Video Access**
- Bit-3 **IDE/Floppy Access**

The four categories are subsets of the primary events as defined in Primary Activity Enable and the occurrence of these events can be checked through a common register Primary Activity Status. As a peripheral timer, GP1 can be used to monitor one (or more than one) of the above four device types by programming the corresponding bit to one and the other bits to zero. Time out of the GP1 timer indicates no activity of the corresponding device type and appropriate action can be taken as a result.

ELECTRICAL SPECIFICATIONS

Absolute Maximum Ratings

Symbol	Parameter	Min	Max	Unit	Comment
T _S	Storage Temperature	-55	125	°C	
T _C	Case Operating Temperature	0	85	°C	
V _{CC}	Core Voltage	-0.5	3.6	Volts	3.3V (VT8233CE is 2.5V)
V _{CC33}	3.3V I/O Voltage	-0.5	3.6	Volts	3.3V
V _{CC25}	2.5V I/O Voltage	-0.5	2.625	Volts	2.5V
V _{SUS33}	Suspend Voltage	-0.5	V _{CC33} + 0.3	Volts	3.3V
V _{CCUSB}	USB Voltage	-0.5	V _{CC33} + 0.3	Volts	3.3V
V _{CCPLL}	PLL Voltage	-0.5	V _{CC25} + 0.25	Volts	2.5V
V _{CCVK}	V-Link Compensation Voltage	-0.5	V _{CC25} + 0.25	Volts	2.5V
V _{BAT}	Battery Voltage	-0.5	V _{CC33} + 0.3	Volts	3.3V
V _{LREF}	V-Link Reference Voltage	-0.5	V _{CC25} * 0.38	Volts	
	Input voltage (3.3V-only inputs)	-0.5	V _{CC33} + 0.3	Volts	FERR#, USBCLK, PWRBTN#, EXTSMI#, BATLOW#, SMBCK1-2, SMBDT1-2

Note: Stress above the conditions listed may cause permanent damage to the device. Functional operation of this device should be restricted to the conditions described under operating conditions.

DC Characteristics

T_C = 0 - 85°C, V_{CC33} = V_{SUS33} = V_{CCUSB} = 3.3V ±5%, V_{BAT} = 3.3V +0.3 / -1.3V

V_{CC} = V_{CC25} = V_{CCVK} = V_{CCPLL} = 2.5V ±5%, V_{LREF} = 0.9V ±5%, GND = 0V

Symbol	Parameter	Min	Max	Unit	Condition
V _{IL}	Input low voltage	-0.5	0.8	V	
V _{IH}	Input high voltage	2.0	V _{CC} +0.3	V	
V _{OL}	Output low voltage	-	0.45	V	I _{OL} = 4.0mA
V _{OH}	Output high voltage	2.4	-	V	I _{OH} = -1.0mA
I _{IL}	Input leakage current	-	±10	uA	0 < V _{IN} < V _{CC}
I _{OZ}	Tristate leakage current	-	±20	uA	0.45 < V _{OUT} < V _{CC}

Power Requirements

Symbol	Parameter	Typ	Max	Unit	Condition
I _{CC}	Power supply current – Core (3.3V)			mA	At max operating frequency
I _{CC25}	Power supply current – I/O (2.5V)			mA	At max operating frequency
I _{CC33}	Power supply current – I/O (3.3V)			mA	At max operating frequency
I _{SUS33}	Power supply current – Suspend (3.3V)			mA	At max operating frequency
I _{CCUSB}	Power supply current – USB (3.3V)			mA	At max operating frequency
I _{CCVK}	Power supply current – V-Link (2.5V)			mA	At max operating frequency
I _{CCPLL}	Power supply current – PLL (2.5V)			mA	At max operating frequency
I _{VLREF}	Power supply current – 0.9V Reference			uA	At max operating frequency
I _{BAT}	Power supply current – RTC Battery		5	uA	At max operating frequency
P _{MAX}	Power dissipation		2.5	W	At max operating frequency

PACKAGE MECHANICAL SPECIFICATIONS

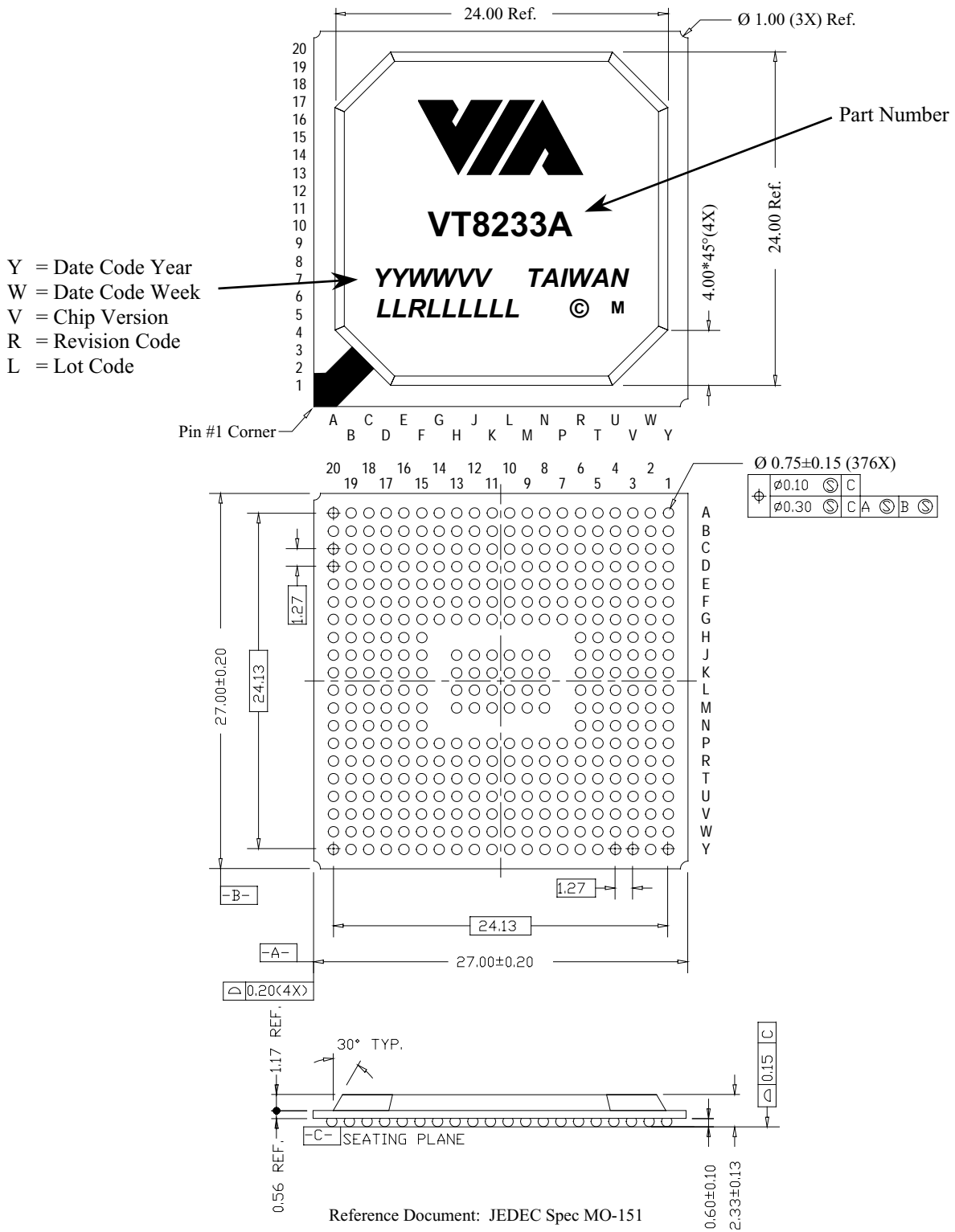

Figure 5. Mechanical Specifications – 376 Pin Ball Grid Array Package