

SV92EX

PCI-Express Soft Modem



FEATURES

- Two-chip, single-lane PCI-Express soft modem solution with an integrated interface that supports the PCI-Express revision 1.1 standard:
 - SV92EX host interface in a 32-pin MLCC.
 - CSP1040 DAA in a 20-pin TSSOP.
- Data mode capabilities:
 - ITU-T™ V.92*: 56000 bits/s—28000 bits/s.
 - ITU-T V.90*: 56000 bits/s—28000 bits/s.
 - ITU-T V.34: 33600 bits/s—2400 bits/s.
 - V.32bis and fallbacks.
 - V.44, V.42, V.42 bis, and MNP™ Class 5 data compression.
 - High compression throughput due to parallel access directly to the host PC.
- FAX mode capabilities:
 - ITU-T.T.31 class 1 FAX.
 - ITU-T V.17: 14400 bits/s, 12000 bits/s, 9600 bits/s, 7200 bits/s (TCM).
 - ITU-T V.29: 9600 bits/s, 7200 bits/s (QAM).
 - ITU-T V.27ter: 4800 bits/s, 2400 bits/s (DPSK).
 - ITU-T V.21 Channel 2: 300 bits/s (FSK).
- CSP1040:
 - System-powered.
 - Proprietary isolation barrier.
 - Programmable event detect for caller-ID reception and power ring detection.
 - Programmable pulse shaping and spark quench.
 - Programmable dc-impedance termination for country-specific VI templates.
 - Programmable ac-impedance termination for return-loss matching.
 - Programmable ringer-impedance emulation.
- Hardware support for pulse dialing for accurate make/break timing.
- Wake-on-ring and caller ID support.
- Common driver across multiple platforms.



The SV92EX chip set using LSI's third-generation silicon DAA is a soft modem solution for PCI-Express applications. The chip set works with LSI's standard soft modem drivers and supports V.92 and lower rates.

The CSP1040 device is LSI's third-generation silicon DAA, which reduces the number of components and board area required to implement a full-featured modem, while achieving compliance with worldwide regulatory requirements. A low-profile digital transformer provides the communications link between the CSP1040 and SV92EX devices. This digital link also provides power to the CSP1040, allowing full operation on marginal phone lines.

The CSP1040 includes hardware support for detecting line-in-use status, overcurrent, polarity reversals, caller ID, and ringing, without the need for additional external circuitry. This allows for full-featured modem designs without increased bill-of-materials or board space.

OPERATING SYSTEM SUPPORT

- Windows® 98, Windows 2000, Windows ME®, and Windows XP 32/64-bit Editions, Windows VISTA 32/64-bit Editions
- Microsoft Designed for Windows logo device requirement compliant

* Actual speeds over U.S. telephone lines vary and are less than 56K due to current FCC regulations and line conditions.

Functional Description

The LSI SV92EX chip set is a two-chip solution consisting of an LSI SV92EX PCI-Express interface and a CSP1040 silicon DAA. It supports V.92/V.90/V.34 data and FAX rates up to 14.4 kbits/s. The SV92EX is an interface device with the memory required for receiving, transmitting, and buffering data sent between the host system (soft modem stack) and the DAA or line codec.

- The SV92EX uses the PCI-Express interface to communicate with the host system or soft modem stack over a single PCI-Express lane. With this interface, the SV92EX can take control of the local bus and exchange data directly with the host system memory.
- The CSP1040 has an integrated line codec and is part of the line interface. The CSP1040 sits on the high-voltage side of the modem circuit. It interfaces with the SV92EX via a digital isolation barrier.

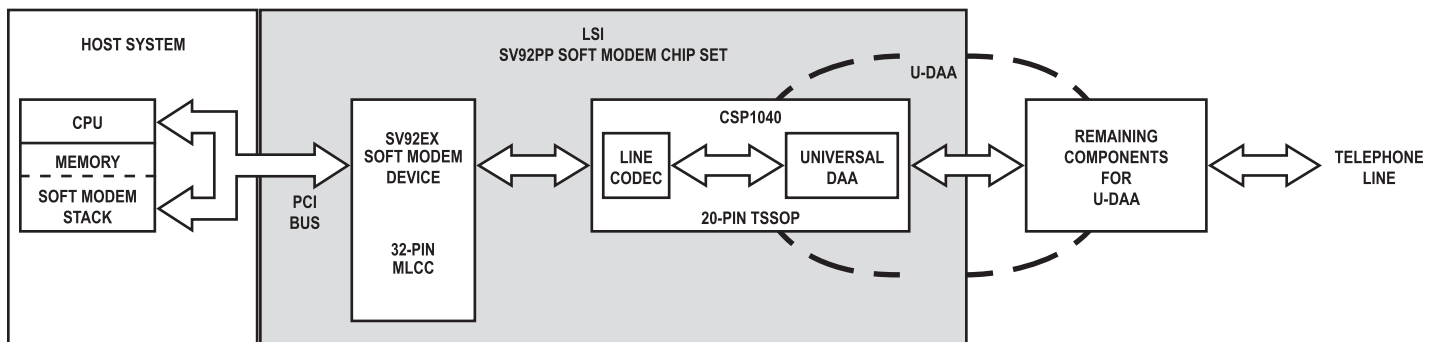

V.92 Features

The ITU-T recommendation for V.92 includes several features that are supported by LSI's soft modem drivers. Downstream connection rates of up to 56000 bits/s are supported when connecting to V.90/V.92 capable server modems through an appropriate path. Not all phone lines can support these connection rates. LSI's soft modem driver will automatically fall back to V.34 rates if a V.90/V.92 connection is not negotiated. When connecting in V.92 mode, the fast-connect feature allows the modem to shorten the start-up time on recognized connections. If call-waiting service is available, the modem-on-hold feature allows the user to place the modem connection on hold and switch to an incoming voice call if desired.

Ordering Information

Table 1. SV92EX Chip Set Part Numbers

DEVICE	PART NUMBER	PACKAGE	COM CODE
L-SV92EX	L-SV92EX-M32-D	32-pin MLCC	7110151050
	L-SV92EX-M32-DT*	32-pin MLCC	7110151060
L-CSP1040	L-CSP1040A3-E11-D	20-pin ETSSOP	7110072260
	L-CSP1040A3-E11-DT*	20-pin ETSSOP	7110072670

* D indicates tubes

DT indicates tube and reel

For more information and sales office locations, please visit the LSI web sites at: lsi.com lsi.com/contacts

LSI Corporation, the LSI logo design, and SANtricity are trademarks or registered trademarks of LSI Corporation. All other brand and product names may be trademarks of their respective companies.

LSI Corporation reserves the right to make changes to any products and services herein at any time without notice. LSI does not assume any responsibility or liability arising out of the application or use of any product or service described herein, except as expressly agreed to in writing by LSI; nor does the purchase, lease, or use of a product or service from LSI convey a license under any patent rights, copyrights, trademark rights, or any other of the intellectual property rights of LSI or of third parties.

Copyright ©2007 by LSI Corporation. All rights reserved.

May 2007 PB07-030DMOD