

# SMX/386™



Includes all PC/ AT motherboard functions

- 40 MHz 80386SX CPU
- 2MB DRAM internal
- DRAM controller supports up to 64M bytes
- Full PC core logic (DMA, interrupt, timer/counter, AT keyboard, RTC)
- Full 8 or 16-bit ISA or PC/104 bus

## Additional Features

- 2 Serial ports (16550 compatible)
- 1 Bi-directional parallel port (EPP/ECP)
- Floppy drive controller
- IDE hard disk drive interface
- Bootable solid state disk
- Watchdog timer & supply voltage monitor
- Embedded BIOS
- DOS Operating system
- 5V only operation
- Low Power with power management capability
- Supports PC/104 interrupt sharing

## GENERAL DESCRIPTION

The SMX/386 OEModule is the fastest, most cost-effective way to incorporate ZF MicroSystems' Single Device PC™ (SDPC), a fully PC/AT compatible system controller into your OEM product with the lowest possible development risk and the greatest reduction in time-to-market. It provides you with a complete PC/AT-compatible motherboard in a module the size of a large integrated circuit. It requires minimal external components because it was designed from its conception for use in embedded systems. Development done on a PC/AT can be transferred directly to the embedded system with little or no modification.

OEModules combine system hardware, software and solid state mass storage in a single compact device. The unique chip-like design of OEModules makes them ideally suited to product designs where low power consumption, high reliability and minimizing overall product size is essential.

## Complete Feature Set

The SMX/386 includes all standard motherboard functions, including 2MB DRAM, serial and parallel I/O, floppy and IDE disk controllers, AT-compatible BIOS, General Software's Mini-DOS ROM, and 256Kb of user-available internal flash for totally solid state operation.

The feature set has been selected to optimize the OEM designer's ability to quickly incorporate IBM PC/AT hardware, software and bus compatibility within proprietary product designs.

## Increased System Reliability

By integrating a full 80386SX AT compatible computer into your proprietary OEM design, you eliminate the necessity for multiple boards within your product. There are no cables to cause reliability problems and no mounting hardware to vibrate loose.

## Industry Standard PC/AT Compatibility

Full compatibility with the PC/AT ISA (Industry Standard Architecture) gives you access to the widest available selection of hardware and software:

Your design starts with proven architecture supported by hundreds of suppliers

Desktop PC volume drives down all component costs

Cost effective development tools and operating systems are readily available

Largest base of standard software applications

OEModules are complete systems that plug directly into your design and expand your design options

## Highly Cost Effective

Inventory management and system assembly are significantly reduced by eliminating as many as half a dozen interconnecting cables, assorted connectors and mounting hardware required with typical single board computers. Field service is also greatly simplified.



ZF MicroSystems, Inc. • 1052 Elwell Court • Palo Alto, CA 94303  
Tel: 415-965-3800 Fax: 965-4050 • Internet: www.zfmicro.com



SMX/386-40-A 05/97

## SPECIFICATIONS: SMX/386-40 OEModule

### 386SX-40 CPU

- Full 32-bit internal architecture
- Cost effective 16-bit hardware environment
- Virtual memory, paging, and hardware enforced protection
- Physical memory space of up to 64 Megabytes
- Sophisticated Power Control Circuit including multiple power down modes for reduced power operation

### DRAM Controller supporting

- High performance MUXed DRAM interleave, CPU pipelined operation
- Programmable DRAM timing, page mode and 2-way interleaving
- Shadow RAM
- Multiple context EMS support

### PC Core Logic with PC/AT compatible:

- DMA controllers
- Interrupt controllers
- Timer/counters
- AT keyboard controller
- Real-time clock

### Serial Ports

- Two 16550 compatible serial ports

### Parallel Port

- Fully compatible with the AT printer port plus bi-directional operation (EPP/ECP)

### Floppy Disk Controller

- Software compatible with the CMOS765B controller for one or two drives
- Integrated digital data separator capable of data transfer rates up to 2Mbps
- Requires no external components

### IDE Hard Disk Controller Interface

- Full 40-pin interface to standard IDE hard disk drive
- Supports up to two IDE drives (master/slave)
- LED activity light support

### Solid State Flash Disk Controller

- Expandable by adding external Flash memory devices
- 512KB Internal Flash Memory
- 256KB Solid State Disk available for OEM software use - normally the boot drive
- Embedded BIOS and Mini-DOS ROM pre-loaded

### Embedded BIOS

- Firmware with support for OEM add-ons and special applications
- Compatible with General Software's Embedded-DOS ROM, Embedded DOS 6-XL, and MS-DOS V.5x & 6x

### DOS Operating System

- General Software's Embedded DOS ROM operating system included
- Full compatibility with MS-DOS interrupts and file systems
- MS-DOS like command set
- Support for standard DOS software
- Supports General Software's Embedded DOS 6-XL real-time operating system - Designs benefit from true multi-threading from the kernel up

- APIs for non-DOS file systems, and other optional features
- Watchdog Timer

## MECHANICAL / ENVIRONMENTAL

- Body Size: 2.20 x 3.00 x .350 inches (55.9 x 76.2 x 8.89 mm)
- Overall Footprint: 2.344 x 3.145 inches (59.54 x 79.88 mm)
- Leads: 240 (50 x 70) gull wing pins at 0.030 inches (0.762mm) width on 0.040 inch (1.016mm) pitch
- Pin-out optimized for ease of bus layout
- Power requirement: +5V only  $\pm 5\%$ , maximums at: 40MHz - 2.2W, 33MHz - 2.0W, 25MHz - 1.7W, 16MHz - 1.45W, 8MHz - 1.05W
- Operating environment:
  - 32°F to 158°F (0° to 70°C)
  - Extended temperature screening available (-40°C to +85°C) - contact factory for additional information
  - 5% to 95% relative humidity, non-condensing
- Storage temperature:
  - -67°F to 185°F (-55° to +85°C)
- Weight: 3 oz. (85.5 gm)

## OFF-MODULE REQUIREMENTS for PC/AT COMPATIBILITY

- DRAM - Memory configuration (discrete components, SIMMs, etc.) entirely at designer's discretion
- RS-232 voltage interface IC if required
- Back-up battery if required for time and date
- Connectors as required: Full 8 or 16-bit ISA or PC/104 bus, COM1, COM2, LPT, keyboard, sound, power, IDE, FDC
- Display Controller if required (a terminal on a serial port may be used as the console)

## ORDERING INFORMATION:

- Order SBX-386 Development Board Kit or ZF3/104 CPUModule Development Kit for evaluation platform

## To order module for production:

- **SMX-386-Q-02:** SMX/386-40 OEModule, BIOS and Embedded DOS ROM only (no documentation or utility software is included)

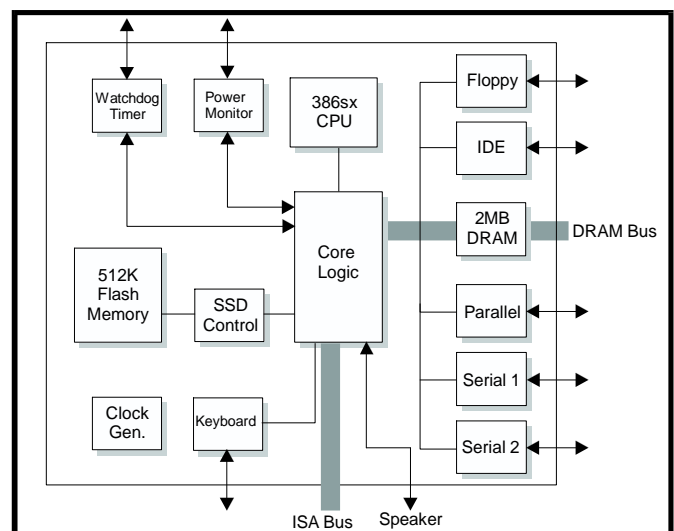

SMX/386-40 Block Diagram