



# **SiI3132 PCI Express to Serial ATA Controller**

## **Data Sheet**

Document # SiI-DS-0138-D

February 2007

## **Copyright Notice**

Copyright © 2007 Silicon Image, Inc. All rights reserved. These materials contain proprietary and confidential information (including trade secrets, copyright and other interests) of Silicon Image, Inc. You may not use these materials except only for your bona fide non-commercial evaluation of your potential purchase of products and/or services from Silicon Image or its affiliates, and/or only in connection with your purchase of products and/or services from Silicon Image or its affiliates, and only in accordance with the terms and conditions herein. You have no right to copy, modify, transfer, sublicense, publicly display, create derivative works of or distribute these materials, or otherwise make these materials available, in whole or in part, to any third party.

## **Trademark Acknowledgment**

Silicon Image™, VastLane™, SteelVine™, PinnaClear™, Simplay™, Simplay HD™, Satalink™, and TMDS™ are trademarks or registered trademarks of Silicon Image, Inc. in the United States and other countries. HDMI™, the HDMI logo and High-Definition Multimedia Interface™ are trademarks or registered trademarks of, and are used under license from, HDMI Licensing, LLC.

## **Further Information**

To request other materials, documentation, and information, contact your local Silicon Image, Inc. sales office or visit the Silicon Image, Inc. web site at [www.siliconimage.com](http://www.siliconimage.com).

## **Revision History**

<b>Revision</b>	<b>Date</b>	<b>Comment</b>
A	4/8/05	Derived from preliminary datasheet rev 0.3
A1	8/15/05	Updated register description for BAR0 Offset 50 <sub>H</sub>
A2	8/11/06	Corrected inconsistent sentences (minor fixes including mistyping)
C	2/2/07	This document is no longer under NDA, removed confidential markings. Updated Marking Specification.
D	2/23/07	Changes to package drawing. New formatting applied.

© 2007 Silicon Image, Inc.

## Table of Contents

<b>Overview</b> .....	<b>1</b>
<b>Features</b> .....	<b>1</b>
Overall Features.....	1
PCI Express Features.....	1
Serial ATA Features.....	1
<b>References</b> .....	<b>1</b>
<b>Electrical Characteristics</b> .....	<b>2</b>
<b>Device Electrical Characteristics</b> .....	<b>2</b>
<b>SATA Interface Timing Specifications</b> .....	<b>4</b>
<b>SATA Interface Transmitter Output Jitter Characteristics</b> .....	<b>4</b>
<b>PCI Express Interface Timing Specifications</b> .....	<b>5</b>
<b>PCI Express Interface Transmitter Output Jitter Characteristics</b> .....	<b>5</b>
<b>CLKI SATA Reference Clock Input Requirements</b> .....	<b>6</b>
<b>Power Supply Noise Requirements</b> .....	<b>6</b>
<b>Pin Definitions</b> .....	<b>7</b>
<b>SiI3132 Pin Listing</b> .....	<b>7</b>
<b>SiI3132 Pin Diagram</b> .....	<b>9</b>
<b>SiI3132 Pin Descriptions</b> .....	<b>10</b>
PCI Express Pins.....	10
Flash / I <sup>2</sup> C / LED Pins.....	10
Serial ATA Signals.....	10
Test Pins.....	11
Power/Ground Pins.....	11
<b>Package Drawing</b> .....	<b>12</b>
<b>Programming Model</b> .....	<b>14</b>
<b>SiI3132 Block Diagram</b> .....	<b>14</b>
<b>SiI3132 SATA Port Block Diagram</b> .....	<b>15</b>
<b>Data Structures</b> .....	<b>17</b>
The Command Slot.....	17
The Scatter/Gather Entry (SGE).....	17
The Scatter/Gather Table (SGT).....	18
The Port Request Block (PRB).....	18
The PRB Control Field.....	19
The PRB Protocol Override Field.....	20
Standard ATA Command PRB Structure.....	20
PACKET Command PRB Structure.....	22
Soft Reset PRB Structure.....	23
External Command PRB Structure.....	24
Interlocked Receive PRB Structure.....	25
<b>Operation</b> .....	<b>26</b>
Command Issuance.....	26
Reset and Initialization.....	26
Port Reset Operation.....	27
Initialization Sequence.....	27
Interrupts and Command Completion.....	28
Interrupt Sources.....	29
Command Completion — The Slot Status Register.....	32

The Attention Bit .....	32
Interrupt Service Procedure .....	32
Interrupt No Clear on Read .....	33
Error Processing.....	33
Error Recovery Procedures.....	34
<b>Auto-Initialization .....</b>	<b>34</b>
<b>Auto-Initialization from Flash .....</b>	<b>35</b>
<b>Auto-Initialization from EEPROM.....</b>	<b>36</b>
<b>Register Definitions.....</b>	<b>38</b>
<b>PCI Configuration Space.....</b>	<b>38</b>
Device ID – Vendor ID.....	39
PCI Status – PCI Command.....	39
PCI Class Code – Revision ID .....	40
BIST – Header Type – Latency Timer – Cache Line Size.....	40
Base Address Register 0.....	41
Base Address Register 1.....	41
Base Address Register 2.....	42
Subsystem ID — Subsystem Vendor ID .....	42
Expansion ROM Base Address.....	43
Capabilities Pointer .....	43
Max Latency – Min Grant – Interrupt Pin – Interrupt Line.....	43
Header Write Enable.....	44
Power Management Capability .....	44
Power Management Control + Status .....	45
MSI Capability .....	45
Message Address.....	46
MSI Message Data.....	46
PCI Express Capability.....	46
Device Capabilities.....	47
Device Status and Control.....	47
Link Capabilities .....	48
Link Status and Control .....	48
Global Register Offset.....	49
Global Register Data.....	49
Port Register Offset.....	49
Port Register Data.....	49
Advanced Error Reporting Capability.....	50
Uncorrectable Error Status.....	50
Uncorrectable Error Mask .....	51
Uncorrectable Error Severity.....	51
Correctable Error Status.....	51
Correctable Error Mask .....	52
Advanced Error Capabilities and Control .....	52
Header Log.....	53
<b>Internal Register Space – Base Address 0.....</b>	<b>54</b>
Port Slot Status Registers .....	54
Global Control .....	55
Global Interrupt Status.....	55
PHY Configuration.....	56
BIST Control Register .....	56
BIST Pattern Register .....	57
BIST Status Register .....	57
I <sup>2</sup> C Control.....	57
I <sup>2</sup> C Status.....	58
I <sup>2</sup> C Slave Address.....	59

I <sup>2</sup> C Data Buffer.....	59
Flash Address.....	59
Flash Memory Data / GPIO Control .....	60
<b>Internal Register Space – Base Address 1 .....</b>	<b>61</b>
Port LRAM.....	62
Port Slot Status.....	63
Port Control Set.....	63
Port Status .....	65
Port Control Clear.....	65
Port Interrupt Status .....	66
Port Interrupt Enable Set / Port Interrupt Enable Clear.....	67
32-bit Activation Upper Address .....	67
Port Command Execution FIFO .....	67
Port Command Error .....	68
Port FIS Configuration.....	69
Port PCI Express Request FIFO Threshold .....	70
Port 8B/10B Decode Error Counter.....	71
Port CRC Error Counter .....	71
Port Handshake Error Counter.....	72
Port PHY Configuration .....	72
Port Device Status Register .....	73
Port Device QActive Register.....	73
Port Context Register .....	74
SControl.....	74
SStatus .....	75
SError .....	76
SActive .....	76
SNotification .....	77
<b>Internal Register Space – Base Address 2 .....</b>	<b>77</b>
Global Register Offset.....	77
Global Register Data .....	77
Port Register Offset.....	78
Port Register Data.....	78
<b>Power Management.....</b>	<b>79</b>
<b>Flash, GPIO, EEPROM, and I<sup>2</sup>C Programming.....</b>	<b>80</b>
<b>Flash Memory Access .....</b>	<b>80</b>
PCI Direct Access.....	80
Register Access.....	80
<b>I<sup>2</sup>C Operation .....</b>	<b>80</b>

## List of Figures

Figure 1. Eye Diagram.....	3
Figure 2. Pin Diagram.....	9
Figure 3. Package Drawing 88 QFN .....	12
Figure 4. Marking Specification .....	13
Figure 5. SiI3132 Block Diagram.....	14
Figure 6. Port Logic Block Diagram.....	15
Figure 7. SiI3132 Interrupt Map.....	30
Figure 8. Auto-Initialization from Flash Timing .....	35
Figure 9. Auto-Initialization from EEPROM Timing.....	36

## List of Tables

Table 1. Absolute Maximum Ratings .....	2
Table 2. DC Specifications.....	2
Table 3. SATA Interface DC Specifications .....	3
Table 4. PCI Express Interface DC Specifications .....	3
Table 5. SATA Interface Timing Specifications .....	4
Table 6. SATA Interface Transmitter Output Jitter Characteristics, 1.5 Gbit/s .....	4
Table 7. SATA Interface Transmitter Output Jitter Characteristics, 3 Gbit/s .....	5
Table 8. PCI Express Interface Timing Specifications .....	5
Table 9. PCI Express Interface Transmitter Output Jitter Characteristics .....	5
Table 10. CLKI SerDes Reference Clock Input Requirement .....	6
Table 11. Power Supply Noise Requirement .....	6
Table 12. Sil3132 Pin Listing .....	7
Table 13. Pin Types .....	8
Table 14. PCI Express Pin Descriptions.....	10
Table 15. Flash / I <sup>2</sup> C / LED Pin Descriptions .....	10
Table 16. Serial ATA Signal Pin Descriptions .....	10
Table 17. Test Pin Descriptions .....	11
Table 18. Power/Ground Pin Descriptions.....	11
Table 19. Package Dimensions .....	12
Table 20. Scatter/Gather Entry (SGE) .....	17
Table 21. Scatter/Gather Table (SGT) .....	18
Table 22. Control Field Bit Definitions .....	19
Table 23. Protocol Override Bit Definitions.....	20
Table 24. Port Request Block for Standard ATA Command .....	20
Table 25. PRB FIS Area Definition.....	21
Table 26. Port Request Block for PACKET Command .....	22
Table 27. Port Request Block for Soft Reset Command .....	23
Table 28. Port Request Block for External Commands .....	24
Table 29. Port Request Block For Receiving Interlocked FIS .....	25
Table 30. Interrupt Steering .....	29
Table 31. Port Interrupt Causes and Control .....	31
Table 32. Auto-Initialization from Flash Timing .....	35
Table 33. Flash Data Description.....	35
Table 34. Auto-Initialization from EEPROM Timing .....	36
Table 35. Auto-Initialization from EEPROM Timing Symbols .....	36
Table 36. EEPROM Data Description.....	37
Table 37. Sil3132 PCI Configuration Space .....	38
Table 38. Sil3132 Internal Register Space – Base Address 0.....	54
Table 39. Sil3132 Internal Register Space – Base Address 1 .....	61
Table 40. Port LRAM layout.....	62
Table 41. Port LRAM Slot layout.....	62
Table 42. Command Error Codes.....	68
Table 43. Default FIS Configurations.....	70
Table 44. SError Register Bits (DIAG Field).....	76
Table 45. Sil3132 Internal Register Space – Base Address 2 .....	77
Table 46. Power Management Register Bits .....	79





## Overview

The Silicon Image SiI3132 is a two-port PCI Express to Serial ATA controller. The SiI3132 is designed to provide multiple-port serial ATA connectivity with minimal host overhead and host-to-device latency. The SiI3132 supports a 1-lane 2.5 Gbit/s PCI Express bus and the Serial ATA Generation 2 transfer rate of 3.0 Gbit/s (300 MByte/s).

## Features

### Overall Features

- Host Protocol:
  - Optimized for transaction oriented designs — minimal Host overhead
  - Supports two command issuance mechanisms:
    - Efficient in both embedded and PC implementations
    - Reduces dependency on bridge behavior
- Supports up to 4-Mbit external flash for BIOS expansion
- Supports a master/slave I<sup>2</sup>C interface
- Supports external flash or serial EEPROM for programmable subsystem vendor ID / subsystem product ID
- Fabricated in a 0.18 $\mu$  CMOS process with a 1.8 volt core and 3.3 volt I/Os
- Available in an 88-pin QFN package (10x10 mm, 0.4 mm lead pitch). **An EPAD must be soldered to PCB GND**
- JTAG boundary scan

### PCI Express Features

- Supports 1-lane 2.5 Gbit/s PCI Express
- Internal application interface multiplexed to 2 ports
- All registers appear in unified memory space
- All registers accessible through I/O space
- Full-chip command completion status accessible with single PCI Express access

### Serial ATA Features

- Integrated Serial ATA Link and PHY logic
- Compliant with Serial ATA 1.0 specifications
- Supports Serial ATA Generation 2 transfer rate of 3.0 Gbit/s
- Plesiochronous, Single PLL architecture, 1 PLL for 2 ports
- Output Swing Control
- Supports two independent Serial ATA channels:
  - Independent Link, Transport, and data FIFO
  - Independent command fetch, scatter/gather, and command execution with hard-coded state machines — no code space or download
  - Supports Legacy Command Queuing (LCQ)
  - Supports Native Command Queuing (NCQ)
  - Supports Non-zero offsets NCQ
  - Supports Out of order data delivery NCQ
  - Supports FIS-based switching with Port Multipliers
- 31 Commands and Scatter/Gather Tables per port on-chip
- Protocol Override per Command
- Staggered Spin-up Control

## References

- Serial ATA / High Speed Serialized AT Attachment specification, Revision 1.0
- PCI Express Base Specification Revision 1.0a

## Electrical Characteristics

### Device Electrical Characteristics

Specifications are for commercial temperature range, 0°C to +70°C, unless otherwise specified.

**Table 1. Absolute Maximum Ratings**

Symbol	Parameter	Ratings	Unit
VDDO	I/O Supply Voltage	4.0	V
VDDD	Core Supply Voltage	2.15	V
VDDSRX, VDDSTX VDDSPLL, VDDPRX VDDPTX, VDDPTXPLL VDDPRXPLL, VDDX	Supply Voltage for SATA and PCI Express Receivers, Transmitters, and PLLs, respectively	2.15	V
V <sub>IN</sub>	Input Voltage	-0.3 ~ VDD+0.3	V
I <sub>OUT</sub>	DC Output Current	16	mA
θ <sub>JA</sub>	Thermal Resistance, Junction to Ambient, Still Air	22.2 <sup>1</sup>	°C/W
T <sub>STG</sub>	Storage Temperature	-65 ~ 150	°C

Notes: <sup>1</sup> An EPAD must be soldered to PCB GND

**Table 2. DC Specifications**

Symbol	Parameter	Condition	Type	Limits			Unit
				Min	Typ	Max	
VDDD	Core Supply Voltage	-	-	1.71	1.8	1.89	V
VDDSRX	SATA Receiver Supply Voltage	-	-				
VDDSTX	SATA Transmitter Supply Voltage	-	-				
VDDSPLL	SATA SerDes PLL Supply Voltage	-	-				
VDDPRX	PCI Exp Receiver Supply Voltage	-	-				
VDDPTX	PCI Exp Transmitter Supply Voltage	-	-				
VDDPTXPLL	PCI Exp Transmitter PLL Supply Voltage	-	-				
VDDPRXPLL	PCI Exp Receiver PLL Supply Voltage	-	-				
VDDX	Oscillator Supply Voltage	-	-				
VDDO	Supply Voltage(I/O)	-	-	3.0	3.3	3.6	V
IDD <sub>1.8V-3G</sub>	Supply Current (1.8V Supply)	3-GHz Operating	-	-	450	570	mA
IDD <sub>1.8V-1.5G</sub>	Supply Current (1.8V Supply)	1.5-GHz Operating	-	-	380	500	mA
V <sub>IH</sub>	Input High Voltage	3.3V I/O		2.0	-	-	V
V <sub>IL</sub>	Input Low Voltage	3.3V I/O				0.8	V
V <sub>+</sub>	Input High Voltage	3.3V I/O	Schmitt	-	1.8	2.3	V
V <sub>-</sub>	Input Low Voltage	3.3V I/O	Schmitt	0.5	0.9	-	V
V <sub>H</sub>	Hysteresis Voltage	3.3V I/O	Schmitt	0.4	-	-	V
I <sub>IH</sub>	Input High Current	V <sub>IN</sub> = VDD	-	-10	-	10	μA
I <sub>IL</sub>	Input Low Current	V <sub>IN</sub> = VSS	-	-10	-	10	μA
V <sub>OH</sub>	Output High Voltage	-	-	2.4	-	-	V
V <sub>OL</sub>	Output Low Voltage	-	-	-	-	0.4	V
I <sub>OZ</sub>	3-State Leakage Current	-	-	-10	-	10	μA

Note: 3.3V power consumption depends on LED, JTAG, Enclosure management status. If all are disabled, 3.3V power consumption will be μA.

**Table 3. SATA Interface DC Specifications**

Symbol	Parameter	Condition	Limits			Unit
			Min	Typ	Max	
V <sub>SATA_DOUT</sub>	TX+/TX- differential peak-to-peak voltage swing.	Terminated by 50 Ω. BAR1 1050h [4:0] = 0x0C <sup>1</sup>	400	550	700	mV
V <sub>SATA_DIN</sub>	RX+/RX- differential peak-to-peak input sensitivity	-	240	-	-	mV
V <sub>SATA_SQ</sub>	RX+/RX- OOB Signal Detection Threshold	-	50	125	240	mV
V <sub>SATA_ACCM</sub>	Tx AC common-mode voltage	-	-	-	50	mV
Z <sub>SATA_DIN</sub>	Tx Pair Differential impedance	-	85	100	115	Ω
Z <sub>SATA_DOUT</sub>	Rx Pair Differential impedance	-	85	100	115	Ω
Z <sub>SATA_SIN</sub>	Tx Single-Ended impedance	-	40	-	-	Ω
Z <sub>SATA_SOUT</sub>	Rx Single-Ended impedance	-	40	-	-	Ω

Notes: <sup>1</sup> 0x0A is a reset value

**Table 4. PCI Express Interface DC Specifications**

Symbol	Parameter	Condition	Limits			Unit
			Min	Typ	Max	
V <sub>PCI_DOUT</sub>	TX+/TX- differential peak-to-peak voltage swing.	Terminated by 50 Ω.	800	1000	1200	mV
V <sub>PCI_DE-RATIO</sub>	Tx De-Emphasized Differential Output Voltage	Ratio	- 3.0	-3.5	-4.0	dB
V <sub>PCI_DIN</sub>	RX+/RX- differential peak-to-peak input sensitivity	-	175	-	1200	mV
Z <sub>PCI_DIN</sub>	Tx Pair Differential impedance	DC impedance	80	100	120	Ω
Z <sub>PCI_DOUT</sub>	Rx Pair Differential impedance	DC impedance	80	100	120	Ω
Z <sub>PCI_SIN</sub>	Tx Single-Ended impedance	DC impedance	40	50	60	Ω
Z <sub>PCI_SOUT</sub>	Rx Single-Ended impedance	DC impedance	40	50	60	Ω
Z <sub>PCI_RX-HIGH-IMP-DC</sub>	Rx Powered Down Impedance	DC impedance	200k	-	-	Ω
Z <sub>PCI_RX-IDLE-DET-DIFFp-p</sub>	Electrical Idle Detect Threshold	Measured at the Rx pins	65	-	175	mV

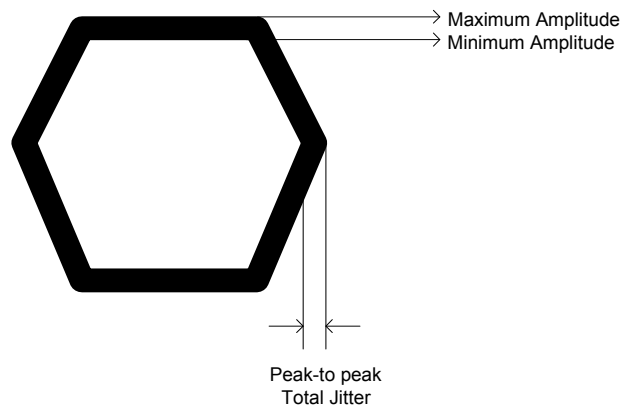

**Figure 1. Eye Diagram**

## SATA Interface Timing Specifications

Table 5. SATA Interface Timing Specifications

Symbol	Parameter	Condition	Limits			Unit
			Min	Typ	Max	
T <sub>TX_RISE_FALL</sub>	Rise and Fall time at transmitter	20%-80% at Gen 1 20%-80% at Gen 2	100 67	-	273 136	ps
T <sub>TX_TOL_FREQ</sub>	Tx Frequency Long Term Stability	-	-350	-	+350	ppm
T <sub>TX_AC_FREQ</sub>	Tx Spread-Spectrum Modulation Deviation	CLKI = SSC AC modulation, subject to the "Downspread SSC" triangular modulation (30-33 kHz) profile per 6.6.4.5 in SATA 1.0 specification	-5000	-	+0	ppm
T <sub>TX_SKEW</sub>	Tx Differential Skew	-	-	-	15	ps

## SATA Interface Transmitter Output Jitter Characteristics

Table 6. SATA Interface Transmitter Output Jitter Characteristics, 1.5 Gbit/s

Symbol	Parameter	Condition	Limits			Unit
			Min	Typ	Max	
TJ <sub>5UI_15G</sub>	Total Jitter, Data-Data 5UI	Measured at Tx output pins peak to peak phase variation Random data pattern	-	80	-	ps
DJ <sub>5UI_15G</sub>	Deterministic Jitter, Data-Data 5UI	Measured at Tx output pins peak to peak phase variation Random data pattern	-	40	-	ps
TJ <sub>250UI_15G</sub>	Total Jitter, Data-Data 250UI	Measured at Tx output pins peak to peak phase variation Random data pattern	-	100	-	ps
DJ <sub>250UI_15G</sub>	Deterministic Jitter, Data-Data 250UI	Measured at Tx output pins peak to peak phase variation Random data pattern	-	60	-	ps

**Table 7. SATA Interface Transmitter Output Jitter Characteristics, 3 Gbit/s**

Symbol	Parameter	Condition	Limits			Unit
			Min	Typ	Max	
T <sub>J</sub> IBAND/10_3G	Total Jitter, $f_{C3dB}=f_{BAUD}/10$	Measured at SATA Compliance Point Random data pattern Load = LL Laboratory Load	-	60	-	ps
D <sub>J</sub> IBAND/10_3G	Deterministic Jitter, $f_{C3dB}=f_{BAUD}/10$	Measured at SATA Compliance Point Random data pattern Load = LL Laboratory Load	-	15	-	ps
T <sub>J</sub> IBAND/500_3G	Total Jitter, $f_{C3dB}=f_{BAUD}/500$	Measured at SATA Compliance Point Random data pattern Load = LL Laboratory Load	-	70	-	ps
D <sub>J</sub> IBAND/500_3G	Deterministic Jitter, $f_{C3dB}=f_{BAUD}/500$	Measured at SATA Compliance Point Random data pattern Load = LL Laboratory Load	-	20	-	ps

## PCI Express Interface Timing Specifications

**Table 8. PCI Express Interface Timing Specifications**

Symbol	Parameter	Condition	Limits			Unit
			Min	Typ	Max	
T <sub>PCI_UI</sub>	Tx / Rx Unit Interval	SSC disabled	399.88	400	400.12	ps
T <sub>PCI_TX_RISE_FALL</sub>	Rise and Fall time at transmitter	20%-80%	0.125	-	-	UI
T <sub>PCI_TX-IDLE-MIN</sub>	Minimum time spent in Electrical Idle	-	50	-	-	UI
T <sub>PCI_TX-IDLE-SET-TO-IDLE</sub>	Maximum time to transition to a valid Electrical Idle after sending an Electrical Idle ordered set	-	-	-	20	UI
T <sub>PCI_TX-IDLE-TO-TO-DIFF-DATA</sub>	Maximum time to transition to valid TX specifications after leaving an Electrical Idle condition	-	-	-	20	UI
T <sub>PVPERL</sub>	Power stable to PERST# inactive	-	100	-	-	ms
T <sub>PERST-CLK</sub>	REFCLK stable before PERST# inactive	-	100	-	-	us
T <sub>PERST</sub>	PERST# active time	-	100	-	-	us

## PCI Express Interface Transmitter Output Jitter Characteristics

**Table 9. PCI Express Interface Transmitter Output Jitter Characteristics**

Symbol	Parameter	Condition	Limits			Unit
			Min	Typ	Max	
T <sub>J</sub> PCle	Total Jitter	Defined by PCI Express Base Specification Rev 1.1	-	65	-	ps

## CLKI SATA Reference Clock Input Requirements

Table 10. CLKI SerDes Reference Clock Input Requirement

Symbol	Parameter	Condition	Limits			Unit
			Min	Typ	Max	
T <sub>CLKI_FREQ</sub>	Nominal Frequency	-	-	25	-	MHz
V <sub>CLKI_IH</sub>	Input High Voltage	-	0.7xVD DX	-	-	V
V <sub>CLKI_IL</sub>	Input Low Voltage	-	-	-	0.3xVD DX	V
T <sub>CLKI_J</sub>	CLKI frequency tolerance	-	-50	-	+50	ppm
T <sub>CLKI_RISE_FALL</sub>	Rise and Fall time at CLKI	25-MHz reference	-	-	4	ns
T <sub>CLKI_RJ</sub>	Random Jitter	Measured at CLKI pin 10 <sup>-12</sup> Bit Error Ratio 1 sigma deviation	-	-	50	psrms
T <sub>CLKI_TJ</sub>	Total Jitter	Measured at CLKI pin 10 <sup>-12</sup> Bit Error Ratio peak-to-peak phase noise	-	-	1	ns
T <sub>CLKI_RC_DUTY</sub>	CLKI duty cycle	20%-80%	40	-	60	%

## Power Supply Noise Requirements

Table 11. Power Supply Noise Requirement

Symbol	Parameter	Condition	Limits			Unit
			Min	Typ	Max	
V <sub>NOISE_VDDA</sub>	1.8V Analog Power Noise	peak-to-peak sinewave across 500-kHz to 3-GHz frequency range.	-	-	50	mV
V <sub>NOISE_VDDD</sub>	1.8V Digital Power Noise		-	-	100	mV
V <sub>NOISE_VDDO</sub>	3.3V IO Power Noise	Measured with differential probe trigger by noise source	-	-	200	mV

## Pin Definitions

### SiI3132 Pin Listing

This section describes the pin-out of the SiI3132 PCI Express to Serial ATA host controller. Table 12 gives the pin numbers, pin names, pin types, drive types where applicable, internal resistors where applicable, and descriptions. Power pins (VDD and VSS) are excluded from this listing.

**Table 12. SiI3132 Pin Listing**

Pin #	Pin Name	Type	Drive	Internal Resistor	Description
4	RX1+	Diff In	-	-	Serial port 1 differential receiver + input
5	RX1-	Diff In	-	-	Serial port 1 differential receiver – input
8	TX1-	Diff Out	-	-	Serial port 1 differential transmitter – output
9	TX1+	Diff Out	-	-	Serial port 1 differential transmitter + output
13	TX0+	Diff Out	-	-	Serial port 0 differential transmitter + output
14	TX0-	Diff Out	-	-	Serial port 0 differential transmitter – output
17	RX0-	Diff In	-	-	Serial port 0 differential receiver – input
18	RX0+	Diff In	-	-	Serial port 0 differential receiver + input
20	REFCLK+	Diff In	-	-	PCI Express differential reference clock + input
21	REFCLK-	Diff In	-	-	PCI Express differential reference clock - input
25	PRX+	Diff In	-	-	PCI Express differential receiver + input
26	PRX-	Diff In	-	-	PCI Express differential receiver – input
29	PTX-	Diff Out	-	-	PCI Express differential transmitter – output
30	PTX+	Diff Out	-	-	PCI Express differential transmitter + output
34	PERST_N	I-Schmitt	-	-	PCI Express Reset
36	LED1	OD	12 mA	-	Channel 1 activity LED indicator
37	LED0	OD	12 mA	-	Channel 0 activity LED indicator
39	FL_DATA0	I/O	8 mA	PU-70k	Flash Memory Data 0
40	FL_DATA1	I/O	8 mA	PU-70k	Flash Memory Data 1
41	FL_DATA2	I/O	8 mA	PU-70k	Flash Memory Data 2
42	FL_DATA3	I/O	8 mA	PU-70k	Flash Memory Data 3
43	FL_DATA4	I/O	8 mA	PU-70k	Flash Memory Data 4
45	FL_DATA5	I/O	8 mA	PU-70k	Flash Memory Data 5
46	FL_DATA6	I/O	8 mA	PU-70k	Flash Memory Data 6
47	FL_DATA7	I/O	8 mA	PU-70k	Flash Memory Data 7
49	FL_ADDR00	I/O	8 mA	PU-70k	Flash Memory Address 0
50	FL_ADDR01	I/O	8 mA	PU-70k	Flash Memory Address 1
51	FL_ADDR02	I/O	8 mA	PU-70k	Flash Memory Address 2
52	FL_ADDR03	I/O	8 mA	PU-70k	Flash Memory Address 3
53	FL_ADDR04	I/O	8 mA	PU-70k	Flash Memory Address 4
55	FL_ADDR05	I/O	8 mA	PU-70k	Flash Memory Address 5
56	FL_ADDR06	I/O	8 mA	PU-70k	Flash Memory Address 6
57	FL_ADDR07	I/O	8 mA	PU-70k	Flash Memory Address 7
58	FL_ADDR08	I/O	8 mA	PU-70k	Flash Memory Address 8
59	FL_ADDR09	I/O	8 mA	PU-70k	Flash Memory Address 9
61	FL_ADDR10	I/O	8 mA	PU-70k	Flash Memory Address 10
62	FL_ADDR11	I/O	8 mA	PU-70k	Flash Memory Address 11

**Table 12. Sil3132 Pin Listing (continued)**

Pin #	Pin Name	Type	Drive	Internal Resistor	Description
63	FL_ADDR12	I/O	8 mA	PU-70k	Flash Memory Address 12
64	FL_ADDR13	I/O	8 mA	PU-70k	Flash Memory Address 13
65	FL_ADDR14	I/O	8 mA	PU-70k	Flash Memory Address 14
68	FL_ADDR15	I/O	8 mA	PU-70k	Flash Memory Address 15
69	FL_ADDR16	I/O	8 mA	PU-70k	Flash Memory Address 16
70	FL_ADDR17	I/O	8 mA	PU-70k	Flash Memory Address 17
71	FL_ADDR18	I/O	8 mA	PU-70k	Flash Memory Address 18
72	FL_RD_N	I/O	8 mA	PU-70k	Flash Memory Read Strobe
73	FL_WR_N	I/O	8 mA	PU-70k	Flash Memory Write Strobe
74	FL_CS_N	I/O	8 mA	PU-70k	Flash Memory Chip Select
76	TMS	I	-	PU-70k	JTAG Test Mode Select
77	TCK	I-Schmitt	-	-	JTAG Test Clock
78	TDI	I	-	PU-70k	JTAG Test Data In
79	TDO	O	4 mA	-	JTAG Test Data Out
80	TRSTN	I	-	PU-70k	JTAG Test Reset
81	SCAN_MODE	I	--	PD-60k	Internal Scan Mode Control
82	I2C_SDAT	I/O-Schmitt	4 mA	PU-70k	I <sup>2</sup> C Serial Data
83	I2C_SCLK	I/O-Schmitt	4 mA	PU-70k	I <sup>2</sup> C Serial Clock
86	XTALO	Analog	-	-	Crystal Output
87	XTALI/CLKI	Analog	-	-	Crystal or Clock Input

**Table 13. Pin Types**

Pin Type	Pin Description
I	Input Pin with LVTTTL Thresholds
I-Schmitt	Input Pin with Schmitt Trigger
O	Output Pin
I/O	Bi-directional Pin
I/O-Schmitt	Bi-directional Pin with Schmitt Trigger
OD	Open Drain Output Pin



## Sil3132 Pin Diagram

Figure 2 shows the pin layout for the Sil3132.

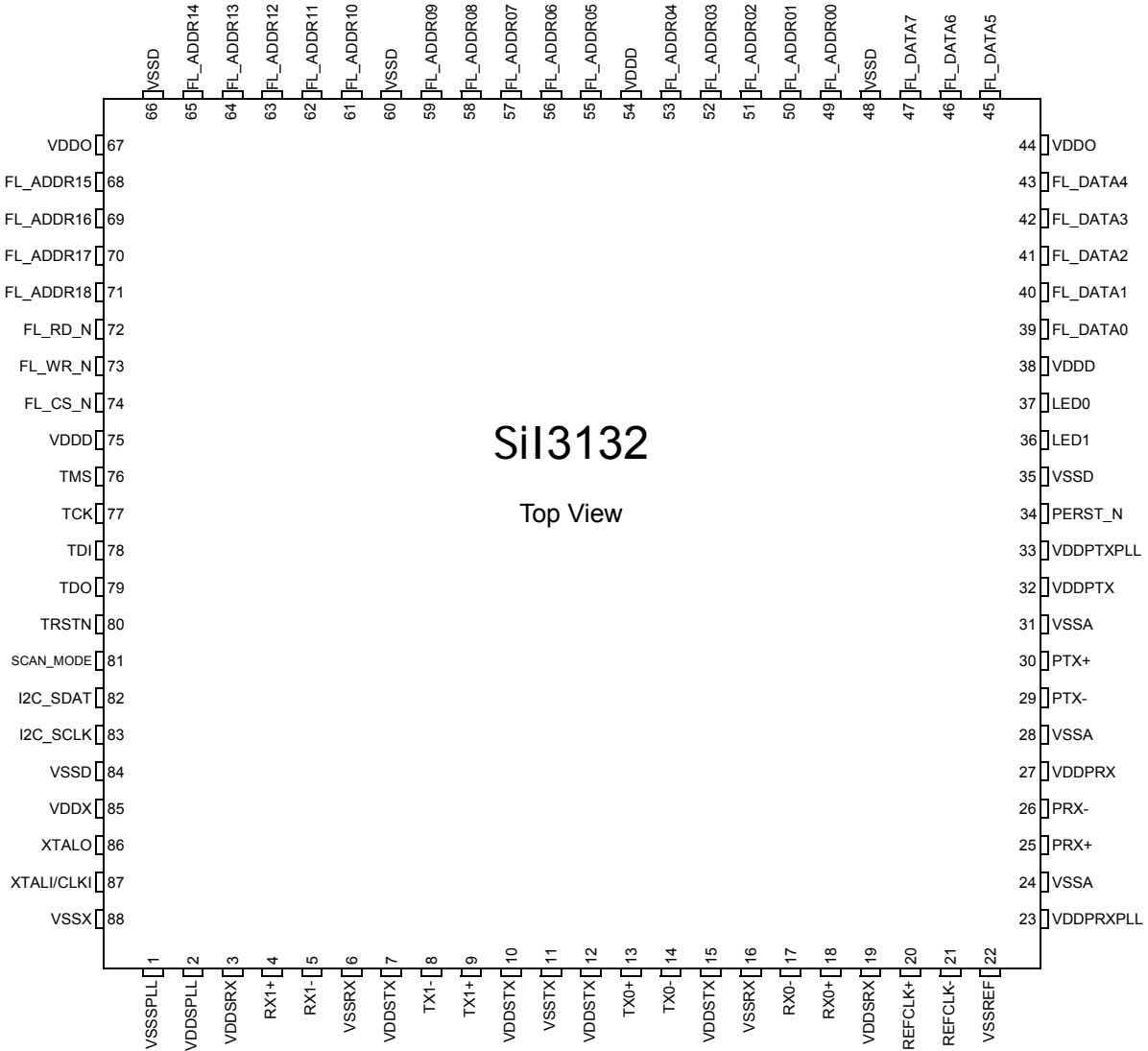

Figure 2. Pin Diagram

## SiI3132 Pin Descriptions

### PCI Express Pins

Table 14. PCI Express Pin Descriptions

Signal Name	Pin Number(s)	Description
PRx+	25	<b>Receive +.</b> Serial receiver differential signal, positive side. Must be AC coupled
PRx-	26	<b>Receive -.</b> Serial receiver differential signal, negative side. Must be AC coupled
PTx+	30	<b>Transmit +.</b> Serial transmitter differential signal, positive side. Must be AC coupled with a 100nF capacitor
PTx-	29	<b>Transmit -.</b> Serial transmitter differential signal, negative side. Must be AC coupled with a 100nF capacitor
REFCLK+	20	<b>Reference Clock +.</b> PCI Express system supplied differential reference clock, positive side. This input signal must be compliant with PCI Express Card Electromechanical Specification Revision 1.0a
REFCLK-	21	<b>Reference Clock -.</b> PCI Express system supplied differential reference clock, negative side. This input signal must be compliant with PCI Express Card Electromechanical Specification Revision 1.0a
PERST_N	34	<b>Reset.</b> PERST_N initializes the PCI Express interface and sets internal registers to their initial state.

### Flash / I<sup>2</sup>C / LED Pins

Table 15. Flash / I<sup>2</sup>C / LED Pin Descriptions

Signal Name	Pin Number(s)	Description
FL_ADDR[18:00]	49-53, 55-59, 61-65, 68-71	<b>Flash Address.</b> FL_ADDR[18:00] is the Flash Memory address for up to 512k of flash Memory.
FL_DATA[07:00]	39-43, 45-47	<b>Flash Data.</b> 8-bit flash memory data bus
FL_RD_N	72	<b>Flash Read Enable.</b> Active low
FL_WR_N	73	<b>Flash Write Enable.</b> Active low
FL_CS_N	74	<b>Flash Chip Select.</b> Active low
I2C_SDAT	82	<b>I<sup>2</sup>C Serial Data.</b> Serial Interface (I <sup>2</sup> C) data line (internally connected to PHY I <sup>2</sup> C data line)
I2C_SCLK	83	<b>I<sup>2</sup>C Serial Clock.</b> Serial Interface (I <sup>2</sup> C) clock (internally connected to PHY I <sup>2</sup> C clock)
LED[1:0]	36, 37	<b>Activity LED.</b> Activity LED drivers for channels 1 and 0.

### Serial ATA Signals

Table 16. Serial ATA Signal Pin Descriptions

Signal Name	Pin Number(s)	Description
Rx[1:0]+	4, 18	<b>Receive +.</b> Serial receiver differential signal, positive side. Must be AC coupled
Rx[1:0]-	5, 17	<b>Receive -.</b> Serial receiver differential signal, negative side. Must be AC coupled
Tx[1:0]+	9, 13	<b>Transmit +.</b> Serial transmitter differential signal, positive side. Must be AC coupled
Tx[1:0]-	8, 14	<b>Transmit -.</b> Serial transmitter differential signal, negative side. Must be AC coupled
XTALI/CLKI	87	<b>Crystal In.</b> Crystal oscillator pin for SerDes reference clock. When external clock source is selected, the 25-MHz external clock will come in through this pin. The clock must be 1.8V swing and the precision recommendation is ±50ppm. Please refer for the detail
XTALO	86	<b>Crystal Out.</b> Crystal oscillator pin for SerDes reference clock. A 25-MHz crystal must be used.

## Test Pins

Table 17. Test Pin Descriptions

Signal Name	Pin Number(s)	Description
TMS	76	<b>JTAG Test Mode Select</b>
TCK	77	<b>JTAG Test Clock</b>
TDI	78	<b>JTAG Test Data In</b>
TDO	79	<b>JTAG Test Data Out</b>
TRSTN	80	<b>JTAG Test Reset.</b> This pin must be tied to ground if JTAG function is not used.
SCAN_MODE	81	<b>Scan Mode.</b> Used for factory testing; do not connect.

## Power/Ground Pins

All like-named power/ground pins, in Table 18 below, are connected together within the package.

Table 18. Power/Ground Pin Descriptions

Pin Name	Pin Number(s)	Description
VDDSRX	3, 19	<b>Receiver Power.</b> These pins provide 1.8V for the Serial ATA receivers.
VSSRX	6, 16	<b>Receiver Ground.</b> These pins provide the Ground reference for the Serial ATA receivers.
VDDSTX	7, 10, 12, 15	<b>Transmitter Power.</b> These pins provide 1.8V for the Serial ATA transmitters.
VSSTX	11	<b>Transmitter Ground.</b> This pin provides the Ground reference for the Serial ATA transmitters.
VDDPRX	27	<b>Receiver Power.</b> This pin provides 1.8V for the PCI Express receivers.
VDDPTX	32	<b>Transmitter Power.</b> This pin provides 1.8V for the PCI Express transmitters.
VDDPTXPLL	33	<b>PLL Power.</b> This pin provides 1.8V for the PCI Express transmitter PLL.
VDDPRXPLL	23	<b>PLL Power.</b> This pin provides 1.8V for the PCI Express receiver PLL.
VSSA	24, 28, 31	<b>PCI-E Ground.</b> These pins provide the Ground reference for the PCI Express SerDes.
VDDSPLL	2	<b>PLL Power.</b> This pin provides 1.8V for the Serial ATA PLL and crystal oscillator.
VSSPLL	1	<b>PLL Ground.</b> This pin provides the Ground reference for the Serial ATA PLL.
VSSREF	22	<b>Reference Clock Ground.</b> This pin provides the Ground reference for the PCI-Express reference clock receiver.
VDDX	85	<b>Oscillator Power.</b> This pin provides 1.8V for the crystal oscillator (associated with XTALI and XTALO pins).
VSSX	88	<b>Oscillator Ground.</b> This pin provides the Ground reference for the crystal oscillator (associated with XTALI and XTALO pins).
VDDO	44, 67	<b>I/O Power.</b> These pins provide 3.3V for the digital I/O.
VDDD	38, 54, 75	<b>Digital Power.</b> These pins provide 1.8V for the digital logic.
VSSD	35, 48, 60, 66, 84	<b>Digital Ground.</b> These pins provide the Ground reference for the digital portion of the chip.

## Package Drawing

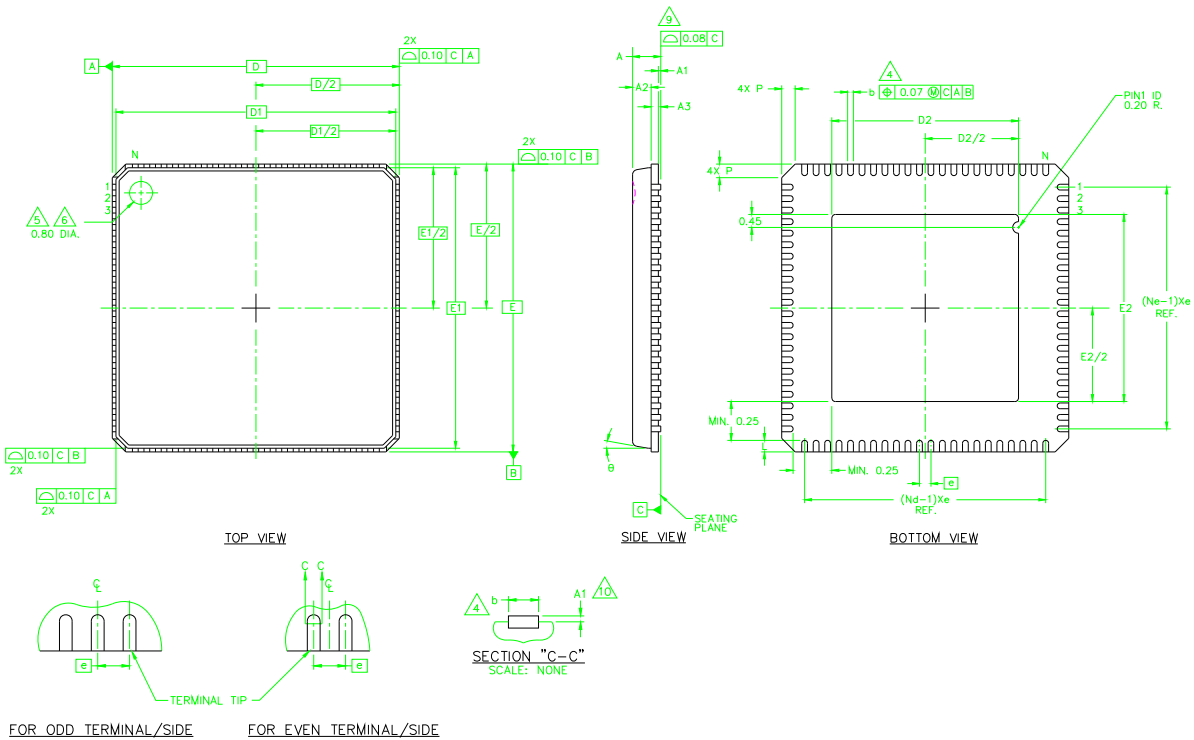

Figure 3. Package Drawing 88 QFN

Table 19. Package Dimensions

Symbol	Dimensions (mm)		
	Minimum	Nominal	Maximum
e		0.40	
L	0.30	0.40	0.50
b	0.15	0.20	0.25
D2	5.85	6.00 <sup>1</sup>	6.65
E2	5.85	6.00 <sup>1</sup>	6.65
A	-	0.85	0.90
A1	0.00	0.02	0.05
A2	-	0.65	0.70
A3	0.20 REF		
D	10.00 BSC		
D1	9.75 BSC		
E	10.00 BSC		
E1	9.75 BSC		
θ			12°
P	0.24	0.42	0.60

Note: <sup>1</sup> It is required that an EPAD is soldered to PCB ground and the landing area be incorporated on the PCB within the footprint of the package corresponding to the EPAD. The size of this landing area can be larger than the exposed pad on the package, should be at least the same as the maximum size of exposed pad of the package (6.65 x 6.65mm). If the traces are within the maximum size of exposed pad, the trace may short to the exposed pad when the package has the exposed pad with the maximum dimension.

Silicon Image, Inc.

### Part Ordering Number

SiI3132CNU (88-pin QFN lead free package with an exposed pad)

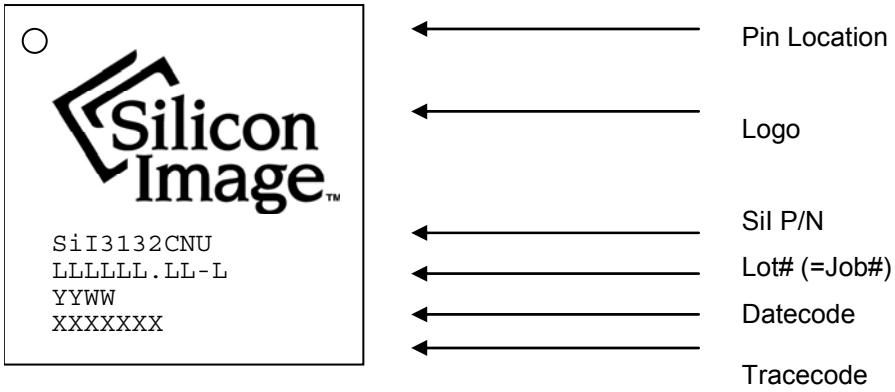

Figure 4. Marking Specification

## Programming Model

### Sil3132 Block Diagram

The Sil3132 programs the major logic modules are illustrated in Figure 5.

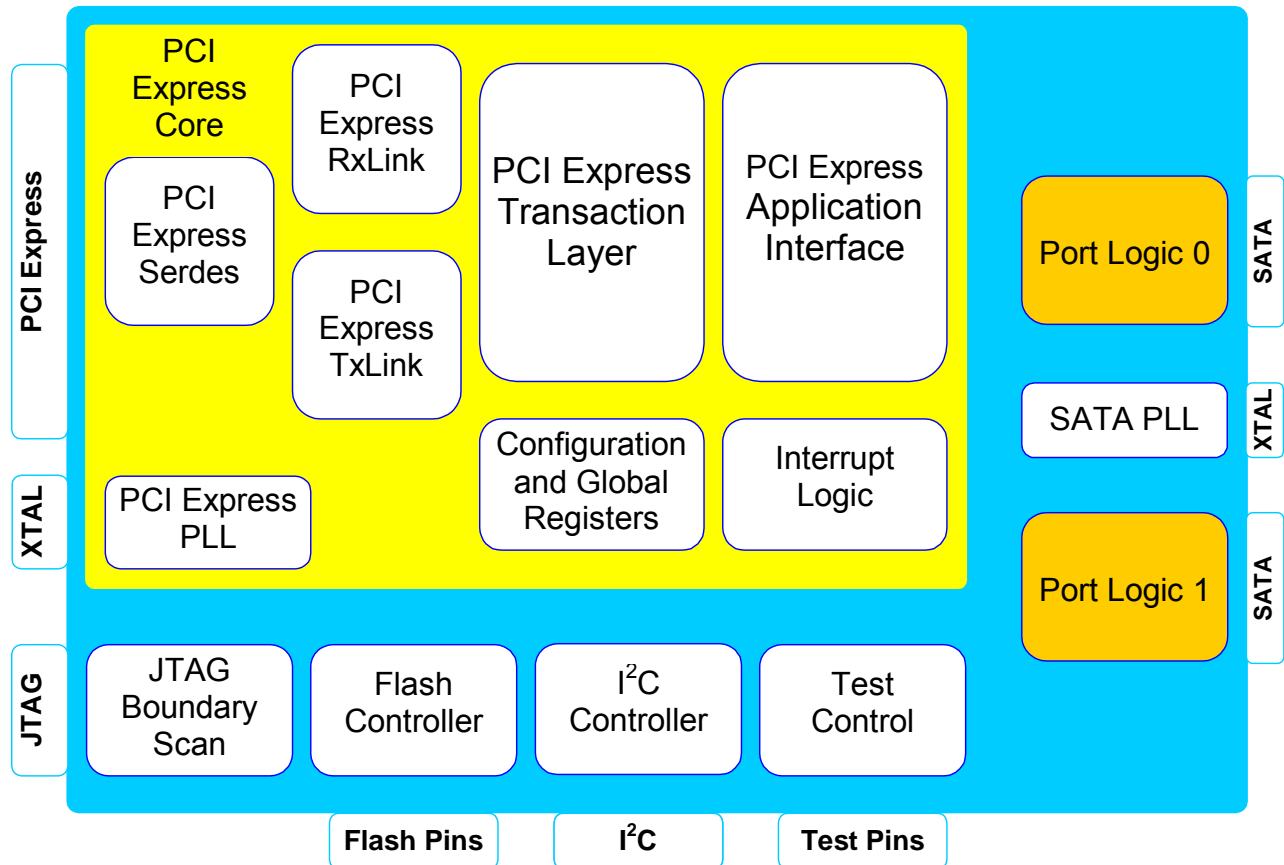

Figure 5. Sil3132 Block Diagram

The PCI Express Core logic block provides PCI Express 1.0a compatibility. The Global Register File block corresponds to the registers addressed by Base Address Register 0; refer to “PCI Express Capability” section on page 46 for more information.

The initialization function provided by the I<sup>2</sup>C Controller and Flash Controller is described in “” section on page 34 for more information.

## Sii3132 SATA Port Block Diagram

The block diagram illustrated in Figure 6 shows the logic structure of each of the Sii3132 SATA Ports.

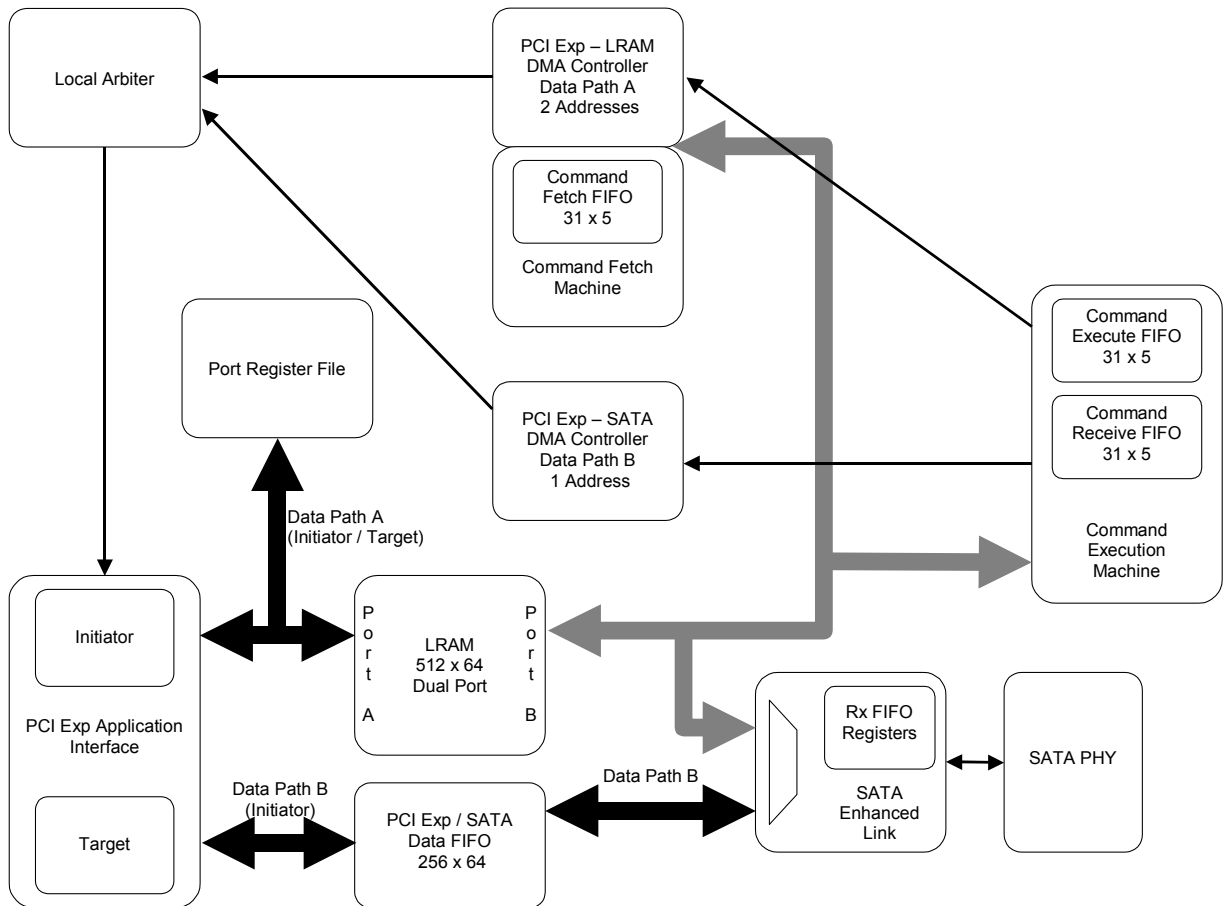

**Figure 6. Port Logic Block Diagram**

The Port Logic consists of:

- A Local Arbiter that arbitrates between the two DMA Controllers
- A DMA Controller for the PCI Express to LRAM Data Path
- A DMA Controller for the PCI Express to Serial-ATA Data Path
- A 512x64 Local RAM (LRAM) that contains: 31 LRAM Slots each of which is 128 bytes (16 Qwords) and 128 bytes used to support 16 Port Multiplier devices (1 Qword per device)
- A Data FIFO that contains 2048 bytes (256 Qwords)
- A State Machine for Command Fetch
- A State Machine for Command Execution
- A Serial-ATA Link
- A Serial-ATA PHY

Each of the two state machines has an associated FIFO which, when non-empty, indicates that processing is required. The FIFO is loaded with a 5-bit command “slot” number to activate a state machine. The slot number can range from 0 to 30, corresponding to the maximum number of active commands supported.

Command flow begins with a host driver building a command in a non-cached region of host memory. The data structure is referred to as a PRB (Port Request Block). The 64-byte PRB is transferred into an available command slot in the LRAM by one of two methods: the direct method or the indirect method. The host driver is responsible

for determining which slots are available. Either of the two command transfer methods may be used for each command transfer. The two methods are:

*Direct Command Transfer Method – Host controlled write to Slot*

In systems that have the capability to perform burst writes, this is the preferred method of command transfer. Embedded systems would most likely use this method. LRAM is directly mapped through use of Base Address Register 1, and appears as a block of memory to the host driver. The host driver writes the PRB contents into the appropriate slot in LRAM. Ideally, this operation is performed as a single PCI Express transaction. The 5-bit slot number (0-30) is written to the *Command Execution FIFO*. The Active bit associated with the selected slot becomes set in the Port Slot Status register. Note that the *Command Fetch FIFO* and *Command Fetch State Machine* are not used for the direct method of command transfer.

*Indirect Command Transfer Method – Sil3132 controlled command transfer*

The host driver builds a PRB in host memory, selects a free slot, and writes the physical address of the PRB into the Activation register corresponding to the selected slot. This causes the Sil3132 to push the 5-bit slot number (0-30) into the *Command Fetch FIFO*. The *Command Fetch State Machine*, while in an idle state, continuously interrogates the *Command Fetch FIFO* for a “non-empty” condition. Upon retrieval of a 5-bit slot number from the FIFO, the *Command Fetch State Machine* retrieves the physical address of the PRB from the corresponding activation register, sets the Active bit associated with the selected slot in the Port Slot Status register, and queues a PCI Express read of the PRB into the associated Slot in LRAM. The *Command Fetch State Machine* waits for completion of the transfer, pushes the 5-bit slot number into the *Command Execution FIFO*, and returns to the idle state, waiting for a non-empty condition in the *Command Fetch FIFO*.

The *Command Execution State Machine* is responsible for directing the flow of the command and response FISes between the command slot and the serial ATA link, directing the flow of data between PCI Express and the serial ATA link, and posting completion status to the host. It is also responsible for error handling when exceptions occur in the normal command flow. Command execution begins when the idle *Command Execution State Machine* recognizes that the serial ATA bus is in a non-busy state and the *Command Execution FIFO* is non-empty. The *Command Execution State Machine* retrieves the 5-bit slot number (0-30) from the *Command Execution FIFO* and uses it to index the command slot in LRAM. The command FIS is addressed and sent to the serial ATA link to be sent to the device. Control flags in the command slot determine the type of data transfer. The *Command Execution State Machine* waits for a response FIS from the device and directs its activities accordingly. If the received FIS is a data FIS, the DMA address and count are determined by examining the Scatter/Gather Entries in the PRB and, if necessary, “walking” a Scatter/Gather Table. The DMA address and count are loaded into the DMA controller and the controller is armed. A DMA activate FIS causes similar behavior, with data flowing from PCI Express to the Serial ATA link. When the command has completed, the Command Completion bit in the Port Interrupt Status register is set to reflect the successful completion of the command. If an error occurred, the Command Error bit is set in the Port Interrupt Status register.

The basic command flow proceeds as follows:

1. The host builds a 64-byte Port Request Block (PRB) that contains:
  - The Register- Host to Device FIS to send to the SATA device
  - Up to two scatter/gather entries to define regions of host memory to be accessed for associated read/write data. Additional scatter/gather entries may be associated with the command.
  - Various optional control flags to direct the Sil3132 to perform special processing, to control interrupt assertion, to vary the normal protocol flow, etc.
2. The host issues the command to the Sil3132.
3. The Sil3132 executes the command, performing all interaction with the SATA device and transferring data between host memory and the SATA device.
4. The Sil3132 asserts a PCI Express interrupt to indicate command completion.
5. The host reads the Sil3132 port slot status to determine which command(s) have completed.



## Data Structures

### The Command Slot

Each port within the SiI3132 contains 31 command slots. The slots are numbered 0 through 30. Each command issued by the host occupies a single command slot. The host decides which slot to use and issues a command to the selected slot. A command slot occupies 128 bytes within the SiI3132 RAM array and consists of a 64 byte PRB (Port Request Block) and a 64-byte scatter/gather table. The host builds the PRB. It contains the Register-Host To Device FIS to transmit to the attached SATA device and up to two scatter/gather entries that define host memory regions to be used for any read/write data associated with the command. If more scatter/gather entries are required to define additional host memory regions, the SiI3132 will fetch them from host memory as needed. The host may simply append the additional SGT entries to the PRB, or one of the scatter/gather entries in the PRB may be used to define an SGT (scatter/gather table) that resides in host memory.

The host may issue commands to any number of available command slots. The host may freely intermix non-queued, legacy queued, native queued, PIO, and DMA command types in any available slot. Commands will always be executed in the order that they were issued. The SiI3132 will enforce command type issuance to the SATA device and will not allow incompatible command types to be issued to a device. This relieves the host of the burden of making sure that incompatible command types are not intermixed in the device.

It is the host's responsibility to manage slot usage. The host must keep track of which slots have commands outstanding and which slots are available for new commands. Issuing a command to a slot that is currently in use will result in unpredictable behavior.

For queued commands, the slot number is used as the queue tag. It is the host's responsibility to ensure that the tag number in the Register-Host to Device FIS defined in the PRB matches the slot number to which the command is issued.

### The Scatter/Gather Entry (SGE)

A scatter/gather entry (SGE) defines a region of host memory to be used for data transfer associated with a command. Each scatter/gather entry defines a single contiguous physically addressed region.

**Table 20. Scatter/Gather Entry (SGE)**

31					0	
Data Address Low						0x00
Data Address High						0x04
Data Count						0x08
TRM (31)	LNK (30)	DRD (29)	XCF (28)	Reserved[27:0]		0x0C

The first quadword, at offset 0, contains the physical address of the region in host memory. The entire 64-bit address must be defined. On 32-bit systems the upper 32 bits must be zero. The data address may point to a region to be used for data transfer, or it may point to a scatter/gather table (SGT), which is a collection of four SGEs. The LNK bit (bit 30 at offset 0x0c) defines the type of region. When LNK is zero, the region is a data region; when LNK is one, the region is a scatter/gather table that will be fetched by the SiI3132 to obtain a data region definition.

The Data Count field at offset 0x08 defines the length, in bytes, of the contiguous data region. When the LNK bit is set to one, indicating an SGT link, the SiI3132 ignores this field.

The TRM bit (bit 31 at offset 0x0c), when set to one, indicates that this is the final SGE associated with the command and no additional SGEs follow it.

The DRD bit (bit 29 at offset 0x0c), when set to one, directs the SiI3132 to discard the data read from the device for the length associated with the data count. When this bit is set to one, the SiI3132 ignores the data address.

The XCF bit (bit 28 at offset 0x0c) indicates whether the region defined by this SGE is to be used for data transfer (XCF set to zero) or an external command fetch (XCF set to one). See section 0 for additional information on external command processing.

## The Scatter/Gather Table (SGT)

The SGT is simply a contiguous collection of four SGEs. The PRB contains two SGEs. When more than two SGEs are required to fully define the entire data transfer of a command, the Sil3132 fetches additional SGEs in groups of four at a time, or one SGT. The SGT occupies the upper 64 bytes of a command slot in Sil3132 RAM. When needed, only one SGT resides in RAM at a time. The Sil3132 fetches each required SGT, overwriting the previous SGT in RAM. Because the first two SGEs reside in the PRB RAM area, they are always available in case the Sil3132 needs to rescan the scatter/gather list for out of order data delivery.

SGTs must reside on a quadword (64-bit) naturally aligned boundary in host memory. In other words, bits[2:0] of the physical address of the SGT in host memory must be zero.

**Table 21. Scatter/Gather Table (SGT)**

31						0
SGE0 Data Address Low					0x00	
SGE0 Data Address High					0x04	
SGE0 Data Count					0x08	
SGE0 TRM	SGE0 LNK	SGE0 DRD	SGE0 XCF	Reserved[27:0]	0x0C	
SGE1 Data Address Low					0x10	
SGE1 Data Address High					0x14	
SGE1 Data Count					0x18	
SGE1 TRM	SGE1 LNK	SGE1 DRD	SGE1 XCF	Reserved[27:0]	0x1C	
SGE2 Data Address Low					0x20	
SGE2 Data Address High					0x24	
SGE2 Data Count					0x28	
SGE2 TRM	SGE2 LNK	SGE2 DRD	SGE2 XCF	Reserved[27:0]	0x2C	
SGE3 Data Address Low					0x30	
SGE3 Data Address High					0x34	
SGE3 Data Count					0x38	
SGE3 TRM	SGE3 LNK	SGE3 DRD	SGE3 XCF	Reserved[27:0]	0x3C	

## The Port Request Block (PRB)

The host builds a PRB to define a command to be executed by the Sil3132. The PRB occupies the first 64 bytes of a command slot in Sil3132 RAM. Once a command is issued, the PRB is overwritten in Sil3132 RAM as necessary to keep track of command context and execution status. The host should not depend on being able to read the contents of the PRB in slot RAM after command issuance. Upon command execution completion, the PRB area of the command slot may contain status information that can be read by the host, dependent upon the command type. The PRB structure can take several forms, dependent upon the command type that it defines.

The PRB contains the following major elements:

- A Control Field to indicate the type of PRB and any features to execute.
- A Protocol Override field used to optionally alter the normal SATA protocol flow.
- A FIS area that contains the initial FIS to be transmitted to the device upon PRB execution.
- Up to two Scatter/Gather entries (SGEs) to define areas of host memory that will be used for any data transfer associated with the PRB. For PACKET commands, the first SGE contains the 12 or 16-byte ATAPI command to be transmitted to the device.

Regardless of whether the command is to be issued with the direct or indirect method, the host driver should build the PRB as a structure in host memory. If the command is to be issued using the direct issuance method, the PRB can be copied from host RAM to the appropriate slot in Sil3132 RAM. If the command is to be issued using the indirect method, the host driver should write the physical address of the PRB to the command activation register associated with the desired command slot.

The PRB must reside on a quadword (64-bit) naturally aligned boundary in host memory. In other words, bits[2:0] of the physical address of the PRB in host memory must be zero.

The PRB can take various forms, depending on the type of command being issued. The command types are:

- **Standard ATA Commands.** This includes all the common ATA commands such as READ SECTORS, WRITE SECTORS, READ DMA, WRITE DMA, IDENTIFY DEVICE, SMART, etc. Also included are the queued commands in both legacy and SATA native queue modes. For these commands, the PRB contains the entire “Register – Host to Device” FIS containing the ATA command. By default, the SiI3132 decodes the ATA command type and executes the necessary SATA protocol automatically. The host driver may, optionally, execute any desired SATA protocol on a per-command basis.
- **PACKET Commands.** ATAPI PACKET commands operate in a similar fashion to the standard ATA commands. The “Register – Host to Device” FIS contains the ATA PACKET command. The 12 or 16-byte ATAPI command is placed in the area normally reserved for the first SGE. The SiI3132 does not decode the contents of the 12 or 16-byte ATAPI command, so the host driver indicates the direction of any data transfer associated with the command.
- **Soft Reset.** A special form of the PRB instructs the SiI3132 to transmit a soft reset sequence to a device. The SiI3132 creates the necessary “Register – Host to Device” FISes required for the sequence. No SGEs are required for this PRB type. Other than the control field, the only item that needs to be populated is the PMP field, to direct the soft reset sequence to the proper device in the event that a port multiplier is attached. Upon successful command completion, the “Register – Device to Host” FIS is available in the command slot, allowing the host driver to view the device signature.
- **External Command.** The external command feature allows the host driver to transmit any arbitrary FIS that will not fit in the FIS area of the PRB. This feature is useful in custom applications that have a need to send large FISes or Data FISes in a fashion that does not comply with the defined SATA protocol
- **Interlocked FIS Reception.** The interlocked FIS feature allows the host driver to receive any desired FIS type directly to a host memory buffer, bypassing all SATA protocol for that FIS type. To use this feature, the host first specifies the FIS type(s) to be interlocked. Then, any number of available command slots can be reserved for the reception of FISes matching the defined type(s).

## The PRB Control Field

The Control Field (offset 0x00, bits [15:0]) is used to indicate the type of PRB and features that are desired. For a standard ATA command, this field will normally contain a default value of 0x0000. Table 22 describes the bit functions for each bit in the Control Field.

**Table 22. Control Field Bit Definitions**

Bit	Name	Description
0	control_protocol_override	The Protocol Override Field is to be used instead of the default protocol for this command.
1	control_retransmit	Allows retransmission if an error occurs during an external command transmission.
2	control_external_command	The command FIS shall be fetched from host memory. This feature is used to send arbitrary FISes that will not fit in the command FIS area of the PRB.
3	control_receive	Reserves a command slot to be used to receive an interlocked FIS as described by the port FIS_CONFIG register.
4	control_packet_read	Indicates that the packet command associated with this PRB will transfer data from the device to the host. This bit must be set for all packet commands that perform read data transfers.
5	control_packet_write	Indicates that the packet command associated with this PRB will transfer data from the host to the device. This bit must be set for all packet commands that perform write data transfers.
6	control_interrupt_mask	Setting this bit to one will prevent the SiI3132 from issuing a normal successful completion interrupt for this command.
7	control_soft_reset	Causes the SiI3132 to issue a soft reset FIS sequence to the device.
15:8	reserved	Must be zero

## The PRB Protocol Override Field

The Protocol Override Field (offset 0x00, bits [31:16]) is used to specify a protocol behavior other than the default for this PRB. PRBs for which the default protocol is to be used should set this field to 0x0000. The SiI3132 will decode the 8-bit ATA command at PRB offset 0x0a and automatically execute the default protocol for the command. In certain cases it might be desirable to specify a non-default protocol to be used, such as with vendor specific device commands. To override the protocol, the host driver must set control\_protocol\_override (Control Field, bit 0) to one and place the desired protocol in this field. Table 23 describes the Protocol Override bit positions.

**Table 23. Protocol Override Bit Definitions**

Bit	Name	Description
16	protocol_packet	This command is to be executed as an ATAPI packet command.
17	protocol_legacy_queue	This command is to be executed as an ATA legacy queued command.
18	protocol_native_queue	This command is to be executed as a SATA native queued command.
19	protocol_read	This command is expected to transfer data from device to host.
20	protocol_write	This command is expected to transfer data from host to device.
21	protocol_transparent	This command is to be executed with no protocol. After the initial command FIS is successfully sent to the device, completion status will be posted without waiting for additional device transmissions.
31:22	Reserved	Must be zero.

Note that there is no distinction between DMA and PIO data transfers in the protocol. The SiI3132 is a native serial ATA device and relies on the SATA interface protocol to determine the data transfer type between the device and the SiI3132. From the host driver's perspective, all commands, whether PIO or DMA, transfer data through use of scatter/gather entries defined in the PRB and scatter/gather tables.

## Standard ATA Command PRB Structure

Table 24 shows the layout for standard ATA commands. The Control and protocol override fields must be populated as described above.

**Table 24. Port Request Block for Standard ATA Command**

31										0	
Protocol Override					Control					0x00	
Received Transfer Count										0x04	
Features / Error		Command / Status			C	R	R	R	PMP	FIS Type	0x08
Dev/Head		Cyl High			Cyl Low				Sector Number		0x0C
Features (Exp)		Cyl High (Exp)			Cyl Low (Exp)				Sector Num (Exp)		0x10
Device Control		Reserved			Sector Count (Exp)				Sector Count		0x14
Reserved		Reserved			Reserved				Reserved		0x18
Reserved – Must Be Zero										0x1C	
SGE0 Data Address Low										0x20	
SGE0 Data Address High										0x24	
SGE0 Data Count										0x28	
SGE0 TRM	SGE0 LNK	SGE0 DRD	SGE0 XCF	Reserved[27:0]						0x2C	
SGE1 Data Address Low										0x30	
SGE1 Data Address High										0x34	
SGE1 Data Count										0x38	
SGE1 TRM	SGE1 LNK	SGE1 DRD	SGE1 XCF	Reserved[27:0]						0x3C	

The Received Transfer Count field (offset 0x04) is reserved as an input to the SiI3132 and should be populated with a value of all zeroes. Upon successful command completion, this field will contain the total number of data bytes received during the command execution. The host driver may use this field to determine the transfer size for commands in which the total transfer size is unknown, such as ATAPI inquiries.

The FIS area (offset 0x08 through 0x1f) must be populated with the initial FIS to be sent to the device. This area contains the FIS header and all task file registers to describe the ATA command. Table 25 describes the FIS area fields.

**Table 25. PRB FIS Area Definition**

Offset	Bit(s)	Name	Description
0x08	7:0	FIS Type	The FIS type field must be populated with a valid SATA FIS type. In all but special custom cases this value will be 0x27, which defines a "Register – Host to Device" FIS type.
	11:8	PMP	4-bit Port Multiplier Port field that defines the port to which this command will be directed. If no port multiplier is attached, this field should be populated with all zeros
	14:12	Reserved	Must be zero.
	15	Command/Device Control	This bit must be set to one to indicate that this FIS contains a command.
	23:16	Task File Command	Populate with the desired ATA command type.
	31:24	Features	Populate with the desired features for this ATA command.
0x0c	7:0	Sector Number (LBA[7:0])	These fields should be populated with desired command-specific parameters.
	15:8	Cylinder Low (LBA[15:8])	
	23:16	Cylinder High (LBA[23:16])	
	31:24	Device/Head (LBA[27:24] for non-extended commands)	
0x10	7:0	Sector Number (Exp.) (LBA[31:24] for extended commands)	These fields should be populated with desired command-specific parameters.
	15:8	Cylinder Low (Exp.) (LBA[39:32] for extended commands)	
	23:16	Cylinder High (Exp.) (LBA[47:40] for extended commands)	
	31:24	Features (Exp.)	
0x14	7:0	Sector Count	These fields should be populated with desired command-specific parameters. The Reserved field must be zero for standard ATA commands that use the "Register –Host to Device" FIS to initiate a command.
	15:8	Sector Count (Exp.)	
	23:16	Reserved	
	31:24	Device Control	
0x18	31:0	Reserved	This field is reserved and must be zero for standard ATA commands that use the "Register – Host to Device" FIS to initiate a command.

## PACKET Command PRB Structure

Table 26 shows the layout for PACKET commands. The Control and protocol override fields must be populated as described above. The PACKET PRB FIS area is structured the same as a standard ATA command. The FIS area contains the PACKET ATA command. After the initial PACKET command is transmitted, the device will respond with a "PIO Setup" FIS, requesting a 12 or 16-byte ATAPI command. The host driver must populate the area normally used for the first SGE with the desired ATAPI command. The length of the ATAPI command is determined by the value of the packet length bit (Port Control, bit 5). If packet length is 0, 12 bytes will be transmitted. If packet length is one, 16 bytes will be transmitted. The packet length field must be initialized with the packet length value returned by the device in the IDENTIFY PACKET command. Table 26 shows a representative 12-byte ATAPI command layout. The highlighted ATAPI packet is an example typical of some commands; other command packets will have different formats within the highlighted bytes.

**Table 26. Port Request Block for PACKET Command**

31				0				
Protocol Override				Control				0x00
Received Transfer Count								0x04
Features / Error	Command / Status	C	R	R	R	PMP	FIS Type	0x08
Dev/Head	Cyl High	Cyl Low				Sector Number		0x0C
Features (Exp)	Cyl High (Exp)	Cyl Low (Exp)				Sector Num (Exp)		0x10
Device Control	Reserved	Sector Count (Exp)				Sector Count		0x14
Reserved	Reserved	Reserved				Reserved		0x18
Reserved – Must Be Zero								0x1C
LBA	LBA (MSB)	Reserved				ATAPI opcode		0x20
XFR Length (MSB)	Reserved	LBA (LSB)				LBA		0x24
Reserved	Reserved	Reserved				XFR Length (LSB)		0x28
Reserved	Reserved	Reserved				Reserved		0x2C
SGE1 Data Address Low								0x30
SGE1 Data Address High								0x34
SGE1Data Count								0x38
SGE1 TRM	SGE1 LNK	SGE1 DRD	SGE1 XCF	Reserved[27:0]				0x3C

The Sil3132 does not decode the ATAPI command to determine the necessity or direction of any associated data transfer. The host driver must supply this information by setting control\_packet\_read (control field, bit4) or control\_packet\_write (control field, bit 5) for any PACKET command that requires data transfer. Failure to set one of these bits for an ATAPI command that requests data transfer will result in an Overrun or Underrun Command Error condition.

## Soft Reset PRB Structure

To send a soft reset sequence, the host driver need only fill in the PMP field (offset 0x8, bits[11:8]) and set control\_soft\_reset (control field, bit 7). The Sil3132 will send a soft reset sequence to the device and wait for a "Register – Device to Host" FIS to deliver the device signature and terminate the command. Upon successful command completion, the host may inspect the FIS area of the slot in Sil3132 RAM (offset 0x08 through 0x1f) to determine the returned device signature. Please note that a soft reset is executed in the same manner as other PRBs. It will be executed in the order in which it was issued. Port Ready (Port Status, bit 31) must be one in order to issue this command. The shaded areas of Table 27 depict valid fields in slot RAM following successful command completion. These fields do not need to be supplied as inputs and may be in any state upon command issuance.

**Table 27. Port Request Block for Soft Reset Command**

31		Control (0x0080)						0	
N/A		Control (0x0080)						0x00	
N/A		N/A						0x04	
Features / Error	Command / Status	C	R	R	R	PMP	FIS Type		
Dev/Head	Cyl High	Cyl Low				Sector Number			
Features (Exp)	Cyl High (Exp)	Cyl Low (Exp)				Sector Num (Exp)			
Device Control	Reserved	Sector Count (Exp)				Sector Count			
N/A		N/A						0x18	
N/A		N/A						0x0C	
N/A		N/A						0x10	
N/A		N/A						0x14	
N/A		N/A						0x18	
N/A		N/A						0x1C	
N/A		N/A						0x20	
N/A		N/A						0x24	
N/A		N/A						0x28	
N/A		N/A						0x2C	
N/A		N/A						0x30	
N/A		N/A						0x34	
N/A		N/A						0x38	
N/A		N/A						0x3C	



**External Command PRB Structure**

An external command PRB is indicated by setting control\_external\_command (control field, bit 2). External commands execute in a manner similar to standard commands except that the initial command FIS is fetched from host memory instead of the PRB FIS area. By default, an external command uses the “transparent” protocol. That is, the command will be terminated immediately following the successful transmission of the external command FIS. If this is not the desired protocol, the host driver can set control\_protocol\_override (control field, bit 0) and place the desired protocol in the Protocol Override field (offset 0x00, bits [31:16]).

The external command FIS length may be any size (up to the 8k SATA limit) and will be automatically padded to a dword boundary. The Sil3132 will frame the FIS, adding SOF, EOF, and CRC. The host memory FIS image must contain the FIS header (FIS Type, PMP, etc.). The PRB PMP field (offset 0x08, bits [11:8]) must be populated to direct the FIS to the desired port multiplier port, or must be zero if no port multiplier is attached. For port multiplier applications, it is important that the PMP field in the host-resident FIS and the PRB match for proper operation.

The location of the external command FIS is defined in additional SGEs with the XCF bit (SGE offset 0x0c, bit 28) set to one. Any type of command may be sent using an external command, including commands that have associated data transfers. Data transfer host memory locations are defined in SGEs with the XCF bit (SGE offset 0x0c, bit 28) set to zero. SGEs used to define the external command FIS and SGEs used to define data transfer may be freely mixed in any order. The presence or absence of the XCF bit informs the Sil3132 whether an SGE should be used for the current transfer operation.

**Table 28. Port Request Block for External Commands**

<b>31</b>	Protocol Override				Control				<b>0</b>	0x00
	Received Transfer Count								0x04	
	Reserved				PMP		Reserved		0x08	
	0x0C									
	0x10									
	0x14									
	0x18									
	Reserved – Must Be Zero								0x1C	
	SGE0 Data Address Low								0x20	
	SGE0 Data Address High								0x24	
	SGE0 Data Count								0x28	
	SGE0 TRM	SGE0 LNK	SGE0 DRD	SGE0 XCF	Reserved[27:0]				0x2C	
	SGE1 Data Address Low								0x30	
	SGE1 Data Address High								0x34	
	SGE1 Data Count								0x38	
	SGE1 TRM	SGE1 LNK	SGE1 DRD	SGE1 XCF	Reserved[27:0]				0x3C	



## Interlocked Receive PRB Structure

Reserving a command slot to receive an interlocked FIS is indicated by setting control\_receive (control field, bit 3). To receive an interlocked FIS into host memory, the host driver first specifies the FIS type(s) to be interlocked by writing the appropriate value to the FIS Configuration register (port registers, offset 0x1028). The PRB is populated with SGEs that define the host memory region(s) that will be used to receive the interlocked FIS. When a FIS of the defined type is received, it will be written to the defined host memory area and the command will be completed. If an error occurs during receipt of the FIS, or the SGEs define an area that is not large enough to contain the entire FIS, the FIS will be rejected with an R\_ERR response and the command will not complete. When an interlocked FIS is received without error into a memory region that is large enough to contain it, the command will be successfully completed and the host driver may use the received FIS in any manner. The command slot is then free to be redefined as a receive slot or as any other command type.

After successfully receiving an interlocked FIS, the low-level link will be receiving WTRM primitives from the transmitting device, which is expecting a response. By default, the Sil3132 waits for the host driver to write a response bit to the port control register. If the host driver writes Interlock Accept (Port Control Set register, bit 12), an R\_OK response will be transmitted. If the host driver writes Interlock Reject (Port Control Set register, bit 11), an R\_ERR response will be transmitted. The host driver may also elect to set Auto Interlock Accept (Port Control Set register, bit 14) before performing interlocked operations. Setting this bit will cause an R\_OK response to be sent for all subsequently received interlocked FISes, without additional intervention from the host driver. It should be noted that in this mode, it is possible to receive one or more additional interlocked FISes before the host driver has had a chance to reserve command slots to receive them. If this occurs, any interlocked FIS that arrives without a reserved slot available will be acknowledged and discarded.

**Table 29. Port Request Block For Receiving Interlocked FIS**

31				0				
Protocol Override				Control				0x00
Received Transfer Count								0x04
								0x08
								0x0C
								0x10
								0x14
								0x18
Reserved – Must Be Zero								0x1C
SGE0 Data Address Low								0x20
SGE0 Data Address High								0x24
SGE0 Data Count								0x28
SGE0 TRM	SGE0 LNK	SGE0 DRD	SGE0 XCF	Reserved[27:0]				0x2C
SGE1 Data Address Low								0x30
SGE1 Data Address High								0x34
SGE1 Data Count								0x38
SGE1 TRM	SGE1 LNK	SGE1 DRD	SGE1 XCF	Reserved[27:0]				0x3C

## Operation

### Command Issuance

Before a command can be executed, it must reside in a slot in Sil3132 RAM and the Sil3132 must be informed that the PRB is ready to be executed. To accomplish this, the host must issue the command in one of two ways:

1. Indirect Command Issuance. The indirect method is the most common and flexible method of issuing commands. With this method, the host builds the PRB in host memory and writes the physical address of the PRB into one of 31 command activation registers, each associated with a command slot. This causes the Sil3132 to fetch the PRB from host memory and deposit it in the selected slot of Sil3132 RAM. After the command is fetched, the Sil3132 automatically informs the execution unit that the command is ready for execution.

The host may issue commands through additional command activation registers at any time without regard as to whether the previous PRB has been fetched. The Sil3132 will fetch the PRBs in the order requested when the necessary resources are available.

2. Direct Command Issuance. The host may write the 64-byte PRB directly into Sil3132 slot RAM. The RAM area is defined in the port register map and the host can easily calculate the slot offset to write the PRB. After the PRB is written to RAM, the host informs the execution unit that it is ready to process by writing the slot number into the command execution FIFO register.

Please note that when the direct command issue method is used, it is not possible to append scatter/gather entries to the PRB without defining a LNK in one of the PRB resident scatter/gather entries.

### Reset and Initialization

The Sil3132 has a hierarchical reset structure that allows initialization of the entire chip, single port, an attached device, or the internal command queue. In general, asserting a reset at a high level will cause all underlying circuits to be reset. There are five levels of reset and initialization possible. The resets, listed from highest to lowest level, are described in the sections that follow.

#### PERST# Reset

The PERST# reset pin, when asserted, holds the entire chip in a reset state. All configuration, global, and port registers are initialized to their default state. When deasserted, PCI Express configuration space is programmable, but the global and port register spaces and the port state machines/command queue remain in a reset state until the Global and Port Resets are deasserted through software control.

#### Global Reset

The Global Reset (Global Control Register, bit 31), when asserted, initializes all global registers, except PHY Configuration, and all port registers to the default state. All Port Resets are set to one (asserted) while Global Reset is asserted. The Global Reset must be cleared to zero to allow access to the global register space or to release any Port Reset. Software may use the Global Reset to initialize all ports with a single operation.

#### Port Reset

Each port contains a Port Reset (Port Control Set/Clear, bit 0) that remains set to one after the Global Reset is cleared to zero. While Port Reset is asserted, all port registers, except Port PHY Configuration and OOB Bypass (Port Control Set/Clear, bit 25), are initialized to their default state. The port state machines are reset and the command queue is cleared. The Port Reset must be cleared to zero by writing a one to bit zero of the Port Control Clear Register to release the Port Reset condition. Software may assert the port reset condition at any time by writing a one to bit zero of the Port Control Set Register.

## Device Reset

Each port contains a Device Reset (Port Control Set, bit 1) that may be used by software to reset an attached device without affecting the contents of the port registers. Writing a one to bit 1 of Port Control Set causes the execution state machines and pending command queue to be initialized. Then, a COMRESET is transmitted to the attached device. The effect of this sequence is to clear any outstanding commands and reset the attached device. The Device Reset bit is self-clearing. After the reset sequence has completed, the bit will be cleared to zero.

## Port Initialize

Each port contains a Port Initialize (Port Control Set, bit 2) that may be used by software to initialize the port data structures without affecting the contents of the port registers or resetting the device. Writing a one to bit 1 of Port Control Set causes the execution state machines and pending command queue to be initialized. The effect of this sequence is to clear any outstanding commands. The Port Initialize bit is self-clearing. After the initialization sequence has completed, the bit will be cleared to zero.

## Port Ready

Each port contains a Port Ready indicator (Port Status, bit 31) that is cleared to zero by any of the above reset conditions. The Port Ready signal, when one, indicates that the port is ready to execute commands. For all resets except Port Initialize, the Port Ready signal will not be asserted until a PHY ready condition is achieved. When Port Initialize is set, Port Ready will be cleared to zero then set to one after any currently active data transfers or FIS transmission/reception operations have completed and port initialization has completed.

## Port Reset Operation

Upon release of Port Reset, the low-level power management state machine is enabled and OOB signaling is initiated to the device. The SiI3132 starts OOB signaling by transmitting a COMRESET to the device. If the device responds with COMINIT and the OOB sequence is successful, a PHY ready condition will result, indicating that a link has been successfully established and the device may transmit an initial register FIS. At this time, the Port Ready signal will be asserted, indicating that the host driver may issue commands. If the device does not respond within the prescribed time allowed for OOB, the low-level power management machine will initiate another OOB sequence after a fixed delay. The period between OOB attempts is approximately 100 milliseconds.

Upon receipt of an initial "Register – Device to Host" FIS that clears the task file status BSY state, the port is allowed to transmit commands to the device.

## Initialization Sequence

The following is an example sequence of events that software might use to initialize the SiI3132 and enumerate an attached device or port multiplier. The sequence assumes that the system has powered up, the PERST# Reset has been deasserted, and the system has enumerated the PCI Express bus. Configuration space, including the Base Address Registers, has been initialized. It is now necessary to enable each port and determine the device type, if any, that is attached to each port.

1. Remove the Global Reset by writing 0x00000000 to the Global Control Register (Global offset 0x40).
2. For each Port to be initialized:
  - a. Clear Port Reset by writing one to Port Reset of Port Control Clear Register (Port offset (port\*0x2000)+0x1004, bit 0).
  - b. If 32-bit platform and 32-bit activation is desired, write one to 32-bit Activation of Port Control Set Register (Port offset (port\*0x2000)+0x1000, bit 10).
  - c. To enable interrupts for command completion and command errors, write 0x00000003 to the Port Interrupt Enable Set Register (Port offset (port\*0x2000)+0x1010).
  - d. To determine if device is present, poll the SStatus Register (Port offset (port\*0x2000)+0x1f04) for a PHYRDY condition indicated by the DET field (bits[3:0]) having a value of 0x3.

- e. Wait until Port Ready in Port Status Register (Port offset (port\*0x2000)+0x1000, bit 31) is one. If desired, an interrupt may be armed in the Port Interrupt Set Register (bit 2). Any change in Port Ready state will assert an interrupt.
- f. If the software supports port multipliers, build a Soft Reset PRB in host memory. Set the PMP field to 0x0f to direct the command to the control port of a port multiplier. Issue the command to any available slot. If the software does not support port multipliers, skip this step, as sending this command will cause the port multiplier to disable legacy access to device 0.
- g. Upon successful command completion of the soft reset command, read the device signature from the command slot (Port offset (port\*0x2000)+(slot\*0x80)+0x14(LSB), 0x0c, 0x0d, 0x0e(MSB)).
- h. If the signature is 0x96690101, then the attached device is a Port Multiplier. Perform the Port Multiplier Enumeration procedure:
  - i. Enable Port Multiplier context switching by writing a one to PM Enable in the Port Control Set Register (Port offset (port\*0x2000)+0x1000, bit 13).
  - ii. Read the Port Multiplier GSCR[2] register by issuing a Read Port Multiplier command to the control port. This register contains the number of device ports on the Port Multiplier.
  - iii. For each Port Multiplier Device Port:
    - 1. Enable the PHY by writing a 1, then a 0 to the Scontrol Register (PSCR[2]) DET field. Issue a Port Multiplier Write command for each of these operations.
    - 2. Wait for a PHYRDY condition in the port by polling the SStatus Register (PSCR[0]).
    - 3. Clear the X-bit and all other error bits in the Serror Register (PSCR[1]) by writing all ones to the register with a Write Port Multiplier command. The port is now ready for operation.
    - 4. Issue a Soft Reset command with the PMP field set to the appropriate port. This will return a device signature for the attached device.
    - 5. Issue the appropriate Identify Device or Identify Packet Device command and any associated Set Features, Set Write Multiple commands as may be necessary to initialize the device.
- i. If the signature is 0xeb140101, then the attached device is an ATAPI PACKET device.
  - i. Issue Identify Packet Device command to get device specific parameters
  - ii. While drive is not ready and timeout has not expired:
    - 1. Issue Test unit ready PACKET command
    - 2. If the command completes successfully, drive is ready
    - 3. Else, if command error indicates Device error condition due to drive not ready, write Initialize Port to the Port Control Register (port\*0x2000)+0x1000, bit 2)
    - 4. Wait until Port Ready in Port Status Register (Port offset (port\*0x2000)+0x1000, bit 31) is one. If desired, an interrupt may be armed in the Port Interrupt Set Register (bit 2). Any change in Port Ready state will assert an interrupt.
  - iii. Drive is ready for use. Issue appropriate Set Features, Set Read Multiple commands as needed.
- j. If the signature is 0x00000101, then the attached device is a disk drive.
  - i. Issue Identify Device command to get device specific parameters
  - ii. Drive is ready for use. Issue appropriate Set Features, Set Read Multiple commands as needed.

## Interrupts and Command Completion

Each port of the SiI3132 produces a single interrupt, which is an accumulation of various possible interrupt events. In its default mode, the SiI3132 combines the interrupts from the ports into a single interrupt that may be used either for INTA emulation or for a Message Signaled Interrupt. In certain embedded environments, it might be desirable for each port to generate an independent interrupt. Software may configure each port to direct its interrupt to one of four emulated interrupts. The Interrupt Steering field in the Port Interrupt Enable Set/Clear register (Port offset 0x1010/1014, bit [31:30]) is used to direct the port interrupt. By default, this field is set to a value of zero, indicating that the interrupt is directed to INTA. The register may be set to one of four values, shown in Table 30.

**Table 30. Interrupt Steering**

Interrupt Steering Value	Interrupt
0	INTA
1	INTB
2	INTC
3	INTD

## Interrupt Sources

Figure 7 on page 30 depicts a logical representation of the interrupt routing for the SiI3132. For each port, the possible interrupt causes are:

- **Command Completion.** Indicates that one or more commands have successfully completed. This interrupt is cleared in one of two ways, dependent upon the state of Interrupt NCoR (Port Control Register, bit 3). Reading the port Slot Status Register will clear this interrupt condition if Interrupt NCoR is zero. Writing a one to bit 0 or 16 of the port Interrupt Status Register will clear this interrupt condition if Interrupt NCoR is one. This interrupt is enabled or disabled with the corresponding bit in the port Interrupt Enable Set/Clear Register.
- **Command Error.** Indicates that a command did not complete successfully. The port Command Error register will contain an error code indicating the actual cause of failure. When this bit is set, Port Ready will be set to zero and no additional commands will be processed until the port is initialized by one of the reset methods and Port Ready is asserted. Writing a one to bit 1 or 17 of the port Interrupt Status Register clears this interrupt condition. This interrupt is enabled or disabled with the corresponding bit in the port Interrupt Enable Set/Clear Register.
- **Port Ready.** Indicates that the Port Ready state has changed from zero to one. Writing a one to bit 2 or 18 of the port Interrupt Status Register clears this interrupt condition. This interrupt is enabled or disabled with the corresponding bit in the port Interrupt Enable Set/Clear Register.
- **Power Management Change.** Indicates that the port power management state has been modified. The current power management state can be determined by reading the port SStatus Register. Writing a one to bit 3 or 19 of the port Interrupt Status Register clears this interrupt condition. This interrupt is enabled or disabled with the corresponding bit in the port Interrupt Enable Set/Clear Register.
- **PHY Ready Change.** Indicates that the PHY state has changed from Not Ready to Ready or from Ready to Not Ready. The current PHY state can be determined by reading the port SStatus Register. Writing a one to bit 4 or 20 of the port Interrupt Status Register clears this interrupt condition. This interrupt is enabled or disabled with the corresponding bit in the port Interrupt Enable Set/Clear Register.
- **COMWAKE Received.** Indicates that a COMWAKE OOB signal has been decoded on the receiver. Writing a one to bit 5 or 21 of the port Interrupt Status Register clears this interrupt condition. This interrupt is enabled or disabled with the corresponding bit in the port Interrupt Enable Set/Clear Register.
- **Unrecognized FIS.** Indicates that the F-bit has been set in the Serror Diag field. Writing a one to bit 6 or 22 of the port Interrupt Status Register clears this interrupt condition. This interrupt is enabled or disabled with the corresponding bit in the port Interrupt Enable Set/Clear Register.
- **Device Exchanged.** Indicates that the X-bit has been set in the Serror Diag field. The X-bit is set upon receipt of a COMINIT from the device. Writing a one to bit 7 or 23 of the port Interrupt Status Register clears this interrupt condition. This interrupt is enabled or disabled with the corresponding bit in the port Interrupt Enable Set/Clear Register.
- **8b/10b Decode Error Threshold Exceeded.** Indicates that the 8b/10b Decode Error counter has exceeded the programmed non-zero threshold value. Writing any value to the port 8b/10b Decode Error Counter Register or writing a one to bit 8 or 24 of the Interrupt Status Clear Register will clear this interrupt condition. This interrupt is enabled by writing a non-zero value to the threshold field (bit[31:16]) of the port 8b/10b Decode Error Counter Register. Writing a zero the threshold field will disable this interrupt.
- **CRC Error Threshold Exceeded.** Indicates that the CRC Error counter has exceeded the programmed non-zero threshold value. Writing any value to the port CRC Error Counter Register or writing a one to bit 9 or 25 of the Interrupt Status Clear Register will clear this interrupt condition. This interrupt is enabled by

writing a non-zero value to the threshold field (bit[31:16]) of the port CRC Error Counter Register. Writing a zero to the threshold field will disable this interrupt.

- **Handshake Error Threshold Exceeded.** Indicates that the Handshake Error counter has exceeded the programmed non-zero threshold value. A handshake error occurs when an R\_ERR primitive is received. Writing any value to the port Handshake Error Counter Register or writing a one to bit 10 or 26 of the Interrupt Status Clear Register will clear this interrupt condition. This interrupt is enabled by writing a non-zero value to the threshold field (bit[31:16]) of the port Handshake Error Counter Register. Writing a zero to the threshold field will disable this interrupt.
- **SDB Notify.** Indicates that a “Set Device Bits” FIS has been received with the N-bit set in the control field. ATAPI and Port Multiplier devices optionally use this feature to signal the host that an event has occurred that requires further scrutiny. Writing a one to bit 11 or 27 of the port Interrupt Status Register clears this interrupt condition. This interrupt is enabled or disabled with the corresponding bit in the port Interrupt Enable Set/Clear Register.

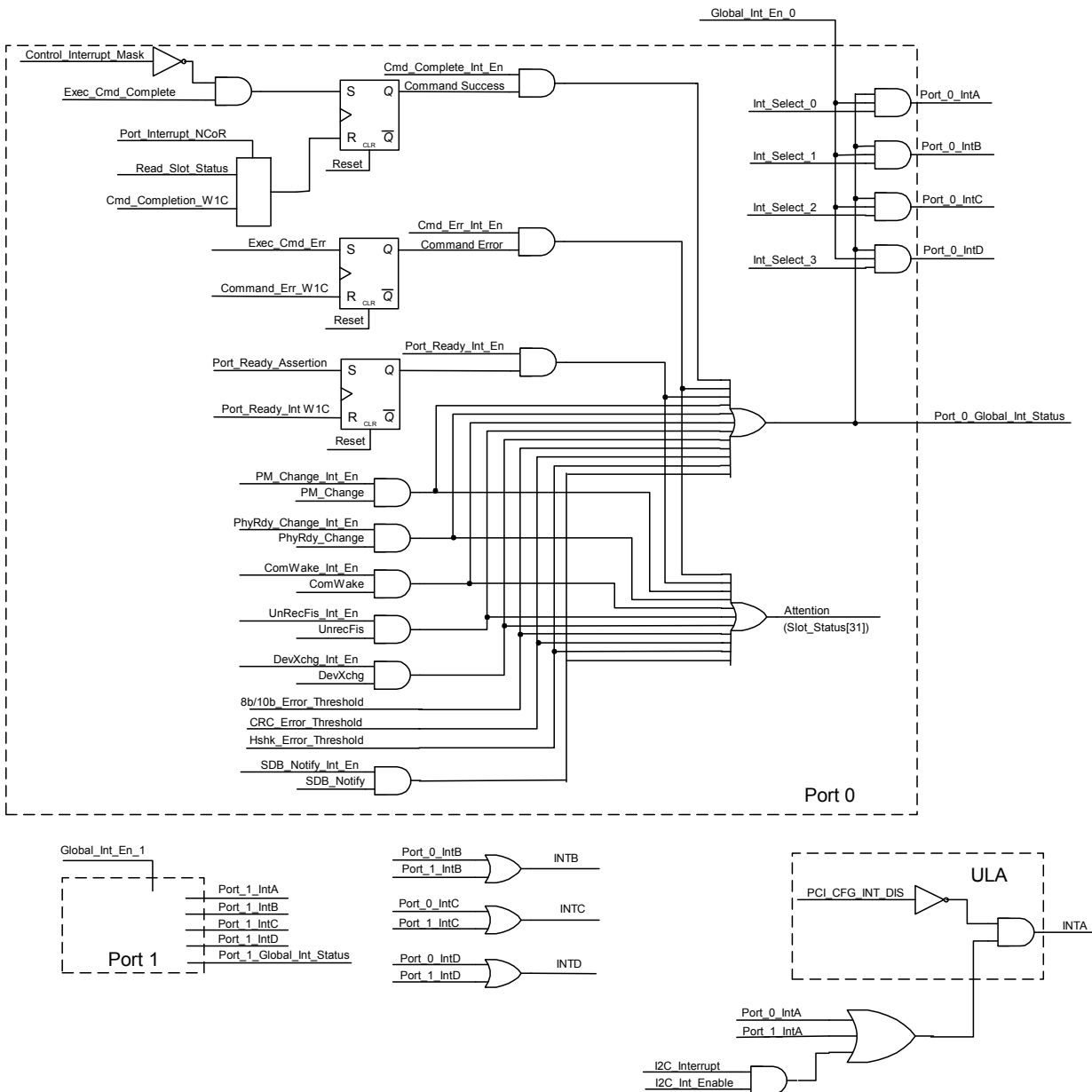

**Figure 7. SiI3132 Interrupt Map**



**Table 31. Port Interrupt Causes and Control**

Interrupt Cause	Interrupt Status Bit		To Clear:	To Enable:	To Disable:
	Masked	Raw			
Command Complete	0	16	If Interrupt W1C == 0 Read Slot Status  If Interrupt W1C == 1 Write 1 to Port Interrupt Status bit 0 or 16, OR, write one to desired port bit(s) in Global Interrupt Status.	Write 1 to Interrupt Enable Set bit 0	Write 1 to Interrupt Enable Clear bit 0 OR Write 1 to control_interrupt_mask in PRB Control field
Command Error	1	17	Write 1 to Interrupt Status bit 1 or 17	Write 1 to Interrupt Enable Set bit 1	Write 1 to Interrupt Enable Clear bit 1
Port Ready	2	18	Write 1 to Interrupt Status bit 2 or 18	Write 1 to Interrupt Enable Set bit 2	Write 1 to Interrupt Enable Clear bit 2
Power Management Change	3	19	Write 1 to Interrupt Status bit 3 or 19	Write 1 to Interrupt Enable Set bit 3	Write 1 to Interrupt Enable Clear bit 3
PHY Ready Change	4	20	Write 1 to Interrupt Status bit 4 or 20	Write 1 to Interrupt Enable Set bit 4	Write 1 to Interrupt Enable Clear bit 4
COMWAKE Received	5	21	Write 1 to Interrupt Status bit 5 or 21	Write 1 to Interrupt Enable Set bit 5	Write 1 to Interrupt Enable Clear bit 5
Unrecognized FIS Received	6	22	Write 1 to Interrupt Status bit 6 or 22	Write 1 to Interrupt Enable Set bit 6	Write 1 to Interrupt Enable Clear bit 6
Device Exchanged	7	23	Write 1 to Interrupt Status bit 7 or 23	Write 1 to Interrupt Enable Set bit 7	Write 1 to Interrupt Enable Clear bit 7
8b/10b Decode Error Threshold	8	24	Write 1 to Interrupt Status bit 8 or 24 OR Write any value to 8b/10b Decode Error Counter bits[15:0]	Write non-zero value to 8b/10b Decode Error Counter bits[31:16]	Write zero to 8b/10b Decode Error Counter bits[31:16]
CRC Error Threshold	9	25	Write 1 to Interrupt Status bit 9 or 25 OR Write any value to CRC Error Counter bits[15:0]	Write non-zero value to CRC Error Counter bits[31:16]	Write zero to CRC Error Counter bits[31:16]
Handshake Error Threshold	10	26	Write 1 to Interrupt Status bit 10 or 26 OR Write any value to Handshake Error Counter bits[15:0]	Write non-zero value to Handshake Error Counter bits[31:16]	Write zero to Handshake Error Counter bits[31:16]
Set Device Bits Notification Received	11	27	Write 1 to Interrupt Status bit 11 or 27	Write 1 to Interrupt Enable Set bit 11	Write 1 to Interrupt Enable Clear bit 11

## Command Completion — The Slot Status Register

The Slot Status register is designed such that an interrupt service routine can determine the successful completion state of outstanding commands, dismiss the command completion interrupt, and determine if any other enabled interrupt events are pending in a port with a single read of the Slot Status register.

The Slot Status Register (Port offset 0x1800 or Global offset 0x00 + (port \* 4)) bits 0 through 30 reflect the status of each of the 31 command slots in a port. When a PRB is issued to a command slot, the corresponding bit in the Slot Status register is set to one, indicating that the command is in progress. When a command is successfully completed, the corresponding command slot bit is cleared in the Slot Status register. The host driver may read the Slot Status register at any time to determine the activity state of any issued commands.

By default, a successfully completed command will set the command complete bit in the port Interrupt Status register. If the Command Complete interrupt is enabled, an interrupt will be asserted simultaneously. The host driver may optionally set `control_interrupt_mask` in the PRB Control field to prevent the command complete bit from being set on a per-command basis. This is useful when the host issues a series of commands and wants to be interrupted only after a selected command completes.

The command complete bit and associated interrupt will be cleared when the Slot Status register is read, unless the host driver has set Interrupt No Clear on Read (Port Control Set/Clear register, bit 3). If Interrupt No Clear on Read is set to one, the host driver must write a one to the Command Complete bit in the Interrupt Status Clear register in order to clear the command complete bit and associated interrupt.

## The Attention Bit

Bit 31 of the Slot Status register is the Attention bit. When set to one, it indicates that an enabled interrupt source, other than command completion, is asserted. It is possible that the Slot Status register can indicate an Attention condition while also showing that commands have successfully completed in bits 0 through 30. The interrupt service routine should always post-process any completed commands in addition to servicing a possible Attention condition. The Attention bit is set only for interrupt conditions that have been enabled as described in the *Interrupt Sources* section. The Attention bit will remain set to one in the Slot Status register until all enabled interrupt conditions have been cleared.

## Interrupt Service Procedure

The Sil3132 is designed to efficiently service interrupt events with minimal host overhead. There are a number of methods that the host may use to quickly determine the interrupt cause within any of the ports. The Global Interrupt Status Register (Global offset 0x44) may be read to determine which ports are interrupting. Then, the Slot Status Register for the interrupting ports may be read to determine the interrupt cause. Alternately, all port Slot Status Registers may be read in a single burst operation from the Global Register space starting at Global offset 0x00. If Interrupt No Clear on Read (port Control Register, Bit 3) is zero, any command complete interrupt will be cleared when the Slot Status registers are read. The host driver should then compare the outstanding command status in bits 0 through 30 to its internal copy of outstanding commands to determine which, if any, commands have successfully completed. Once the successful command completions have been noted, the host should check the Attention bit (bit 31) to determine if any other enabled interrupt events are pending on the port. If the Attention bit is one, the host should read the port Interrupt Status Register (Port offset (port\*0x2000)+0x1008) to ascertain the cause for the Attention condition. Once the Attention condition has been resolved and cleared, normal processing may continue.



## Interrupt No Clear on Read

By default, the Command Completion interrupt condition is cleared when the port Slot Status Register is read. In some cases, such as debug environments, clearing of the Command Completion interrupt might not be the desired effect of reading the Slot Status Register. In these cases, the host driver should set the Interrupt No Clear on Read bit (bit 3) in the port Control Register. When this bit is set, the host must clear the Command Completion interrupt by one of the following methods:

1. Write a one to the corresponding port interrupt status bit(s) in the Global Interrupt Status Register (Global offset 0x44). Or,
2. Write a one to bit 0 or bit 16 of the port Interrupt Status Register (Port offset (port\*0x2000)+ 0x1008).

Method 1 allows Command Complete interrupts for multiple ports to be cleared in a single write operation.

Method 2 will clear Command Complete only for the corresponding port.

## Error Processing

When an error occurs during command processing, the SiI3132 records the error condition and halts execution until the host driver is able to restore normal operation. The SiI3132 does not attempt to automatically recover from error conditions. Rather, it provides the host with the necessary information to handle the error condition. Errors that occur during command execution cause the Command Error bit to be set to one in the port Interrupt Status Register (Port offset (port\*0x2000)+ 0x1008) and an error code to be placed in the port Command Error Register (Port offset (port\*0x2000)+ 0x1024). Please see section documenting the "Port Command Error" register on page 68 for a complete list of possible error codes. Execution is then halted. Port Ready (Port Status Register, bit 31) will be cleared to zero. Only the port with the error condition is halted. All other ports will continue to process normally. If the Command Error interrupt is enabled, an interrupt is asserted and the Attention bit is asserted in the port Slot Status Register. The corresponding Slot Status bit for the command in error will NOT be cleared to zero, because the command did not complete successfully. If only non-queued commands are outstanding, the slot number for the command in error is available in the Port Status Register, bits[20:16]. The host may use this information to ascertain which outstanding command caused the error condition.

To recover from a Command Error condition, it is necessary to initialize the port by one of the Port Reset methods described in section 0 (Reset and Initialization). It might not be necessary to reset the device in all error cases. In fact, to properly recover from native queued error conditions, it may be necessary to send additional commands to the device in error to obtain additional error information. At the minimum, it will be necessary to assert a Port Initialize and wait for Port Ready before additional commands may be issued.

Errors may be grouped into three categories to determine the proper recovery action:

- Recoverable errors. Error codes 1 and 2 are device specific errors. These errors occur when the device returns an error bit in the final register FIS or in a Set Device Bits FIS. Depending upon the severity of the error type reported by the device, it might not be necessary to reset the device. If the error code is 1, the register FIS received from the device is available in the command slot PRB. The host may determine the error reported by the device by examining the error register field of this structure. Please see section 0 for more information regarding error recovery procedures.
- Locally detected data errors. Error code 3 is a unique error type. It indicates that the SiI3132 detected an error during command execution but the device failed to report the error upon command completion. For non-queued commands, this error type may be treated the same as a recoverable error. If queued commands are outstanding, the device must be reset because it is necessary to make sure that all queued commands are flushed from the device upon an error condition. Because the device did not report an error, it is unlikely that the queue has been flushed in the device.
- Fatal Errors. All other error codes indicate that an error condition has occurred that requires both the device and the internal operational state of the SiI3132 to be reset. The most common method to perform this function is to issue a Device Reset.

## Error Recovery Procedures

When a device returns error status for an outstanding command, the Sil3132 will halt command processing, post an error type of 1 or 2 in the Port Command Error register, set the command error bit in the interrupt status register and, if enabled, assert an interrupt to the host. The host driver may wish to attempt error recovery without resetting the device that issued the error. Note that error recovery procedures should only be attempted for error types 1 and 2. Error type 3 is also recoverable if no queued commands are outstanding. It is recommended that all other error types result in a reset of the affected device(s).

If the device in error is directly attached to the Sil3132 device port, the host may simply issue a Port Initialize by setting bit 2 in the Port Control Set register and waiting for a Port Ready condition. The host may then re-issue any commands that were outstanding when the error occurred. If native queued commands were outstanding, the host should issue a READ LOG EXTENDED for Log Page 10h to determine the details of the error condition. Refer to the Serial ATA II specification for further details on error handling with native queuing.

If the device in error is attached to a port multiplier, it is necessary for the host driver to wait until all outstanding commands to other devices attached to the port multiplier have completed before issuing the Port Initialize function. This is accomplished through a series of steps:

1. The host driver must note the PM port number for the device in error by extracting the PMP field (bit[8:5]) from the Port Context Register (port offset 0x1e04). The PMP field contains the PM port number for the device in error. It is then necessary to determine if any commands are outstanding for non-error devices. If there are no commands outstanding for non-error devices, the host driver may simply proceed to step 4 to issue a Port Initialize and wait for a Port Ready condition before reissuing commands.
2. If commands are outstanding to non-error devices, the host should set the Port Resume bit (bit 6) in the Port Control Set Register. Setting this bit will cause the following actions:
  - a. Force a Device Busy condition for the currently selected PM port (the port to which the device in error is attached) so that no additional issued commands will be sent to the device in error.
  - b. Continue processing of commands that have been issued.
3. The host driver must monitor command completion progress and determine when all commands for non-error devices have completed. Please note that the Port Slot Status register will still have a bit set for each outstanding command on the device in error. These bits will not be cleared and the host must ignore them while waiting for command completion on non-error devices. If another recoverable error occurs while waiting for commands to complete, the host driver must follow the same recovery steps for the new device in error, starting with step 1 above. It is possible to have multiple devices in an error recovery state concurrently. When the host driver has detected that all commands for non-error devices have completed, it must perform the following steps.
  - a. Clear Port Resume (Port Control Clear Register, Bit 6).
  - b. Clear bit[16:13] in the Port Device Status Register for the device(s) in error ((port\*0x2000) + 0xf80 + (PM port of device in error \* 8)). This action clears the device\_busy, native\_queue, legacy\_queue, and service\_pending bits to ready the device for further command processing.
  - c. Write zeroes (0x00000000) to the Port Device QActive Register for the device(s) in error ((port\*0x2000) + 0xf84 + (PM port of device in error \* 8)). This action ensures that all queued command context is removed before re-issuing commands.
  - d. Issue a Port Initialize and wait for Port Ready condition.
4. The host driver may now resume normal command processing. The host driver must determine which commands need to be re-issued to the device in error. Note that if native queued commands were outstanding to the device in error, the host must issue a READ LOG EXTENDED command to clear the pending error condition and determine the tag number (slot number) of the command in error before resuming command processing.

**Note:** It is a good idea to clear Port Resume (Port Control Clear Register, Bit 6) whenever a Port Initialize or Port Device Reset is issued. This ensures that the Port Resume bit is always cleared when starting normal processing in the event that an abnormal exit is taken from the error recovery procedure.

## Auto-Initialization

The Sil3132 supports an external flash and/or EEPROM device for BIOS extensions and user-defined PCI configuration header data.

## Auto-Initialization from Flash

The Sil3132 initiates the flash detection and configuration space loading sequence upon the release of PERST#. It begins by reading the highest two addresses (7FFFF<sub>H</sub> and 7FFFE<sub>H</sub>), checking for the correct data signature pattern – AA<sub>H</sub> and 55<sub>H</sub>, respectively. If the data signature pattern is correct, the Sil3132 continues to sequence the address downward, reading a total of twelve bytes. If the Data Signature is correct (55<sub>H</sub> at 7FFFC<sub>H</sub>), the last eight bytes are loaded into the PCI Configuration Space registers.

If both flash and EEPROM are installed, the PCI Configuration Space registers will be loaded with the EEPROM's data.

While the sequence is active, the Sil3132 responds to all PCI bus accesses with a Target Retry.

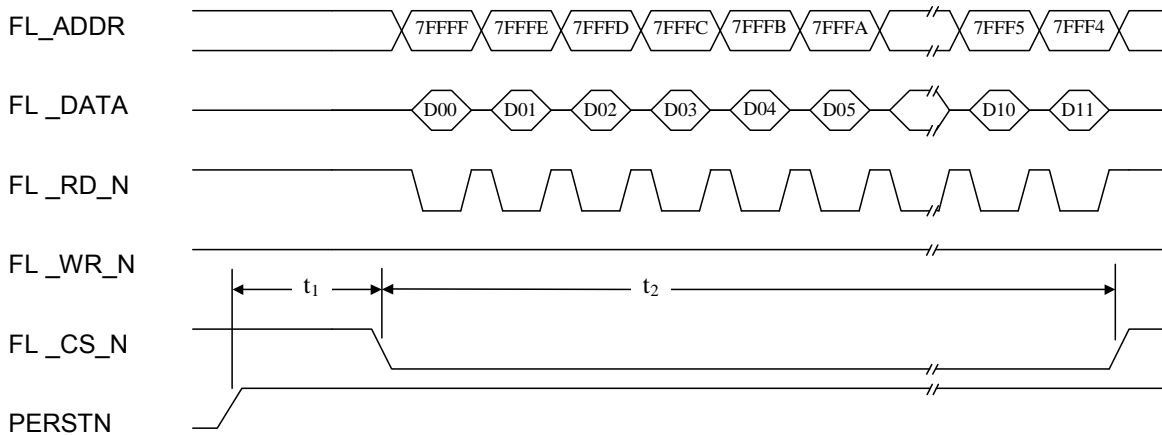

Figure 8. Auto-Initialization from Flash Timing

Table 32. Auto-Initialization from Flash Timing

Parameter	Value	Description
t <sub>1</sub>	660 ns	PCI reset to flash Auto-Initialization cycle begin
t <sub>2</sub>	4200 ns	Flash Auto-Initialization cycle time

Table 33. Flash Data Description

Address	Data Byte	Description
7FFFF <sub>H</sub>	D00	Data Signature = AA <sub>H</sub>
7FFFE <sub>H</sub>	D01	Data Signature = 55 <sub>H</sub>
7FFFD <sub>H</sub>	D02	AA = 120 ns flash device / Else, 240 ns flash device
7FFFC <sub>H</sub>	D03	Data Signature = 55 <sub>H</sub>
7FFFB <sub>H</sub>	D04	PCI Device ID [23:16]
7FFFA <sub>H</sub>	D05	PCI Device ID [31:24]
7FFF9 <sub>H</sub>	D06	PCI Class Code [15:08]
7FFF8 <sub>H</sub>	D07	PCI Class Code [23:16]
7FFF7 <sub>H</sub>	D08	PCI Sub-System Vendor ID [07:00]
7FFF6 <sub>H</sub>	D09	PCI Sub-System Vendor ID [15:08]
7FFF5 <sub>H</sub>	D10	PCI Sub-System ID [23:16]
7FFF4 <sub>H</sub>	D11	PCI Sub-System ID [31:24]

## Auto-Initialization from EEPROM

The Sil3132 initiates the EEPROM detection and configuration space loading sequence after the flash read sequence. The Sil3132 supports EEPROMs with an I<sup>2</sup>C serial interface. The sequence of operations consists of the following.

1. START condition defined as a high-to-low transition on I2C\_SDAT while I2C\_SCLK is high.
2. Control byte = 1010 (Control Code) + 000 (Chip Select) + 0 (Write Address)
3. Acknowledge
4. Starting address field = 00000000.
5. Acknowledge
6. Sequential data bytes separated by Acknowledges.
7. STOP condition.

While the sequence is active, the Sil3132 responds to all PCI bus accesses with a Target Retry.

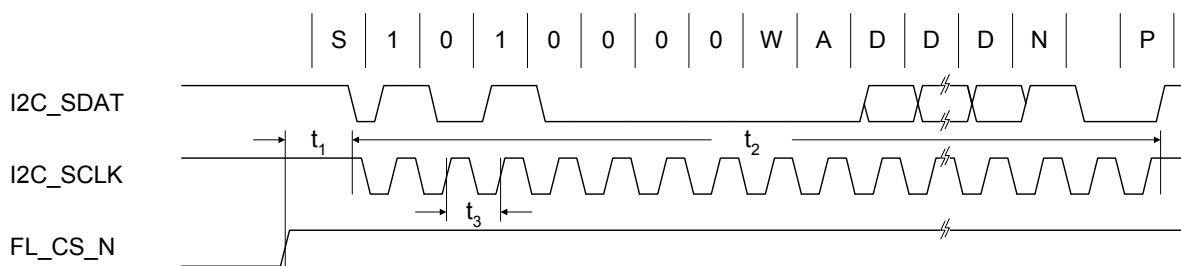

Figure 9. Auto-Initialization from EEPROM Timing

Table 34. Auto-Initialization from EEPROM Timing

Parameter	Value	Description
$t_1$	26.00 $\mu$ s	End of Auto-Initialization from flash to start of Auto-Initialization from EEPROM
$t_2$	1.4 ms	Auto-Initialization from EEPROM cycle time
$t_3$	10 $\mu$ s	EEPROM serial clock period

Table 35. Auto-Initialization from EEPROM Timing Symbols

Parameter	Description
S	START condition
W	R/W 0 = Write Command, 1 = Read Command
A	Acknowledge
D	Serial data
N	No-Acknowledge
P	STOP condition

**Table 36. EEPROM Data Description**

Address	Data Byte	Description
00 <sub>H</sub>	D00	Memory Present Pattern = AA <sub>H</sub>
01 <sub>H</sub>	D01	Memory Present Pattern = 55 <sub>H</sub>
02 <sub>H</sub>	D02	Data Signature = AA <sub>H</sub>
03 <sub>H</sub>	D03	Data Signature = 55 <sub>H</sub>
04 <sub>H</sub>	D04	PCI Device ID [23:16]
05 <sub>H</sub>	D05	PCI Device ID [31:24]
06 <sub>H</sub>	D06	PCI Class Code [15:08]
07 <sub>H</sub>	D07	PCI Class Code [23:16]
08 <sub>H</sub>	D08	PCI Sub-System Vendor ID [07:00]
09 <sub>H</sub>	D09	PCI Sub-System Vendor ID [15:08]
0A <sub>H</sub>	D10	PCI Sub-System ID [23:16]
0B <sub>H</sub>	D11	PCI Sub-System ID [31:24]

## Register Definitions

This section describes the registers within the Sil3132.

### PCI Configuration Space

As shown in Table 37, the PCI Configuration Space registers define the operation of the Sil3132 on the PCI Express bus.

**Table 37. Sil3132 PCI Configuration Space**

Address Offset	Register Name			
00 <sub>H</sub>	Device ID		Vendor ID	
04 <sub>H</sub>	PCI Status		PCI Command	
08 <sub>H</sub>	PCI Class Code			Revision ID
0C <sub>H</sub>	BIST	Header Type	Latency Timer	Cache Line Size
10 <sub>H</sub>	Base Address Register 0			
14 <sub>H</sub>				
18 <sub>H</sub>				
1C <sub>H</sub>	Base Address Register 1			
20 <sub>H</sub>	Base Address Register 2			
24 <sub>H</sub>	Reserved			
28 <sub>H</sub>	Reserved			
2C <sub>H</sub>	Subsystem ID		Subsystem Vendor ID	
30 <sub>H</sub>	Expansion ROM Base Address			
34 <sub>H</sub>	Reserved			Capabilities Ptr
38 <sub>H</sub>	Reserved			
3C <sub>H</sub>	Max Latency	Min Grant	Interrupt Pin	Interrupt Line
40 <sub>H</sub>	Reserved			
44 <sub>H</sub>	Reserved			
48 <sub>H</sub>	Reserved			Hdr Wr Ena
4C <sub>H</sub>	Reserved			
50 <sub>H</sub>	Reserved			
54 <sub>H</sub>	Power Management Capabilities		Next Capability	Pwr Mgt Cap ID
58 <sub>H</sub>	Data	Reserved	Control and Status	
5C <sub>H</sub>	Message Control		Next Capability	MSI Cap ID
60 <sub>H</sub>	Message Address			
64 <sub>H</sub>				
68 <sub>H</sub>	Reserved		Message Data	
6C <sub>H</sub>	Reserved			
70 <sub>H</sub>	PCI Express Capabilities Register		Next Capability	PCI Exp Cap ID
74 <sub>H</sub>	Device Capabilities			
78 <sub>H</sub>	Device Status		Device Control	
7C <sub>H</sub>	Link Capabilities			
80 <sub>H</sub>	Link Status		Link Control	
84 <sub>H</sub> -EF <sub>H</sub>	Reserved			
F0 <sub>H</sub> -FF <sub>H</sub>	Indirect Access			
100 <sub>H</sub>	Advanced Error Reporting Capability			
104 <sub>H</sub>	Uncorrectable Error Status			
108 <sub>H</sub>	Uncorrectable Error Mask			
10C <sub>H</sub>	Uncorrectable Error Severity			

**Table 37. Sii3132 PCI Configuration Space (continued)**

Address Offset	Register Name
110 <sub>H</sub>	Correctable Error Status
114 <sub>H</sub>	Correctable Error Mask
118 <sub>H</sub>	Advanced Error Capabilities and Control
11C <sub>H</sub> -12B <sub>H</sub>	Header Log

### Device ID – Vendor ID

Address Offset: 00<sub>H</sub>  
Access Type: Read /Write  
Reset Value: 0x3132\_1095

31	30	29	28	27	26	25	24	23	22	21	20	19	18	17	16	15	14	13	12	11	10	09	08	07	06	05	04	03	02	01	00
Device ID																Vendor ID															

This register defines the Device ID and Vendor ID associated with the Sii3132. The register bits are defined below.

- **Bit [31:16]:** Device ID (R/W) – Device ID. The value in this bit field is one of the following:
  - The default value of 0x3132 to identify the device as a Silicon Image Sii3132 .
  - The value loaded from an external memory device; if an external memory device – flash or EEPROM – is present with the correct signature, the Device ID is loaded from that device after reset. See “Auto-Initialization from Flash” section on page 35 for more information.
  - System programmed value; if bit 0 of the Configuration register (48<sub>H</sub>) is set, the Device ID is system programmable.
- **Bit [15:00]:** Vendor ID (R) – Vendor ID. This field defaults to 0x1095 to identify the vendor as Silicon Image.

### PCI Status – PCI Command

Address Offset: 04<sub>H</sub>  
Access Type: Read/Write/Write-One-to-Clear  
Reset Value: 0x0010\_0000

31	30	29	28	27	26	25	24	23	22	21	20	19	18	17	16	15	14	13	12	11	10	09	08	07	06	05	04	03	02	01	00
Det Par Err	Sig Sys Err	Rcvd M Abort	Rcvd T Abort	Sig T Abort	Reserved	Det M Par Err	Reserved	Capabilities List	Int Status	Reserved											Int Disable	Reserved	SERR Enable	Reserved	Par Error Resp	Reserved	Bus Master	Memory Space	IO Space		

This register defines the various control functions associated with the PCI bus. The register bits are defined below.

- **Bit 31:** Det Par Err (R/W1C) – Detected Parity Error.
- **Bit 30:** Sig Sys Err (R/W1C) – Signaled System Error.
- **Bit 29:** Rcvd M Abort (R/W1C) – Received Master Abort.
- **Bit 28:** Rcvd T Abort (R/W1C) – Received Target Abort.
- **Bit 27:** Sig T Abort (R/W1C) – Signaled Target Abort.
- **Bit 24:** Det M Par Err (R/W1C) – Detected Master Data Parity Error.
- **Bit 20:** Capabilities List (R) – PCI Capabilities List. This bit is hardwired to 1 to indicate that the Sii3132 implements Capabilities registers for Power Management, PCI-X, and Message Signaled Interrupt.

- **Bit [19]:** Interrupt Status (R).
- **Bit [26:25,23:21,18:11,9,7,5:3]:** Reserved (R). This bit field is reserved and returns zeros on a read.
- **Bit [10]:** Interrupt Disable (R/W).
- **Bit 08:** SERR Enable (R/W) – SERR Enable.
- **Bit 06:** Par Error Resp (R/W) – Parity Error Response Enable.
- **Bit 02:** Bus Master (R/W) – Bus Master Enable. This bit set enables the Sil3132 to act as PCI bus master, i.e., issue Memory Requests.
- **Bit 01:** Memory Space (R/W) – Memory Space Enable. This bit set enables the Sil3132 to respond to memory space accesses.
- **Bit 00:** I/O Space (R/W) – I/O Space Enable. This bit is hardwired to 0; the Sil3132 does not respond to I/O space accesses.

**PCI Class Code – Revision ID**

Address Offset: 08<sub>H</sub>  
 Access Type: Read/Write  
 Reset Value: 0x0180\_0001

31	30	29	28	27	26	25	24	23	22	21	20	19	18	17	16	15	14	13	12	11	10	09	08	07	06	05	04	03	02	01	00
PCI Class Code																								Revision ID							

This register defines the various control functions associated with the PCI bus. The register bits are defined below.

- **Bit [31:08]:** PCI Class Code (R) – PCI Class Code. This value in this bit field is one of the following:
  - The default value of 018000h for Mass Storage Class.
  - The value loaded from an external memory device; if an external memory device – flash or EEPROM – is present with the correct signature, the PCI Class Code is loaded from that device after reset. See “Auto-Initialization from Flash” section on page 35 for more information.
  - System programmed value; if bit 0 of the Configuration register (48<sub>H</sub>) is set the PCI Class Code is system programmable.
- **Bit [07:00]:** Revision ID (R) – Chip Revision ID. This bit field is hardwired to indicate the revision level of the chip design; revision 01<sub>H</sub> is defined by this specification.

**BIST – Header Type – Latency Timer – Cache Line Size**

Address Offset: 0C<sub>H</sub>  
 Access Type: Read/Write  
 Reset Value: 0x0000\_0000

31	30	29	28	27	26	25	24	23	22	21	20	19	18	17	16	15	14	13	12	11	10	09	08	07	06	05	04	03	02	01	00
BIST								Header Type								Latency Timer								Cache Line Size							

This register defines the various control functions associated with the PCI bus. The register bits are defined below.

- **Bit [31:24]:** BIST (R). This bit field is hardwired to 00<sub>H</sub>.
- **Bit [23:16]:** Header Type (R). This bit field is hardwired to 00<sub>H</sub>.
- **Bit [15:08]:** Latency Timer (R). This field is hardwired to 00<sub>H</sub>.
- **Bit [07:00]:** Cache Line Size (R/W). This bit field is Read/Write for legacy purposes. The field is not used by the Sil3132.



## Base Address Register 0

Address Offset: 10<sub>H</sub>

Access Type: Read/Write

Reset Value: 0x0000\_0000\_0000\_0004

63	62	61	60	59	58	57	56	55	54	53	52	51	50	49	48	47	46	45	44	43	42	41	40	39	38	37	36	35	34	33	32
Base Address Register 0																															
31	30	29	28	27	26	25	24	23	22	21	20	19	18	17	16	15	14	13	12	11	10	09	08	07	06	05	04	03	02	01	00
Base Address Register 0																								0000100							

This register defines the addressing of the Global Registers within the SiI3132. The register bits are defined below.

- **Bit [63:07]:** Base Address Register 0 (R/W). This register defines the base address for the 128-byte Memory Space containing the Global Registers.
- **Bit [06:00]:** (R). This bit field is hardwired to 0000100<sub>B</sub> to indicate a 64-bit base address.

## Base Address Register 1

Address Offset: 18<sub>H</sub>

Access Type: Read/Write

Reset Value: 0x0000\_0000\_0000\_0004

63	62	61	60	59	58	57	56	55	54	53	52	51	50	49	48	47	46	45	44	43	42	41	40	39	38	37	36	35	34	33	32
Base Address Register 1																															
31	30	29	28	27	26	25	24	23	22	21	20	19	18	17	16	15	14	13	12	11	10	09	08	07	06	05	04	03	02	01	00
Base Address Register 1														00 0000 0000 0100																	

This register defines the addressing of the Port Registers and LRAM within the SiI3132. The register bits are defined below.

- **Bit [63:15]:** Base Address Register 1 (R/W). This register defines the base address for the 16kbyte Memory Space containing the Port Registers.
- **Bit [14:00]:** (R). This bit field is hardwired to 0004<sub>H</sub> to indicate a 64-bit base address.

## Base Address Register 2

Address Offset: 20<sub>H</sub>  
 Access Type: Read/Write  
 Reset Value: 0x0000\_0001

31	30	29	28	27	26	25	24	23	22	21	20	19	18	17	16	15	14	13	12	11	10	09	08	07	06	05	04	03	02	01	00
Base Address Register 2																								000 0001							

This register defines the addressing of the Indirect I/O registers within the SiI3132. The register bits are defined below.

- **Bit [31:04]:** Base Address Register 2 (R/W). This register defines the base address for the 128-byte I/O Space.
- **Bit [03:00]:** (R). This bit field is hardwired to 000\_0001<sub>B</sub>.

## Subsystem ID — Subsystem Vendor ID

Address Offset: 2C<sub>H</sub>  
 Access Type: Read/Write  
 Reset Value: 0x3132\_1095

31	30	29	28	27	26	25	24	23	22	21	20	19	18	17	16	15	14	13	12	11	10	09	08	07	06	05	04	03	02	01	00
Subsystem ID																Subsystem Vendor ID															

This register defines the Subsystem ID fields associated with the PCI bus. The register bits are defined below.

- **Bit [31:16]:** Subsystem ID (R/W) – Subsystem ID. The value in this bit field is one of the following:
  - The default value of 0x3132
  - The value loaded from an external memory device; if an external memory device – flash or EEPROM – is present with the correct signature, the Subsystem ID is loaded from that device after reset. See “Auto-Initialization from Flash” section on page 35 for more information.
  - System programmed value; if bit 0 of the Configuration register (48<sub>H</sub>) is set the Subsystem ID is system programmable.
- **Bit [15:00]:** Subsystem Vendor ID (R/W) – Subsystem Vendor ID. The value in this bit field is one of the following:
  - The default value of 0x1095
  - The value loaded from an external memory device; if an external memory device – flash or EEPROM – is present with the correct signature, the Subsystem Vendor ID is loaded from that device after reset. See “Auto-Initialization from Flash” section on page 35 for more information.
  - System programmed value; if bit 0 of the Configuration register (48<sub>H</sub>) is set the Subsystem Vendor ID is system programmable.

## Expansion ROM Base Address

Address Offset: 30<sub>H</sub>  
Access Type: Read/Write  
Reset Value: 0x0000\_0000

31	30	29	28	27	26	25	24	23	22	21	20	19	18	17	16	15	14	13	12	11	10	09	08	07	06	05	04	03	02	01	00
Expansion ROM Base Address																		000_0000_0000_0000_000									Exp ROM Enable				

This register defines the Expansion ROM base address associated with the PCI bus. The register bits are defined below.

- **Bit [31:19]:** Expansion ROM Base Address (R/W) – Expansion ROM Base Address. This bit field defines the upper bits of the Expansion ROM base address.
- **Bit [18:01]:** (R). This bit field is hardwired to 00000<sub>H</sub> to indicate that the Expansion ROM address range is 512k bytes.
- **Bit [00]:** Exp ROM Enable (R/W) – Expansion ROM Enable. This bit is set to enable Expansion ROM access.

## Capabilities Pointer

Address Offset: 34<sub>H</sub>  
Access Type: Read  
Reset Value: 0x0000\_0054

31	30	29	28	27	26	25	24	23	22	21	20	19	18	17	16	15	14	13	12	11	10	09	08	07	06	05	04	03	02	01	00
Reserved																		Capabilities Pointer													

This register defines the link to a list of new capabilities associated with the PCI bus. The register bits are defined below.

- **Bit [31:08]:** Reserved (R). This bit field is reserved and returns zeros on a read.
- **Bit [07:00]:** Capabilities Pointer (R) – Capabilities Pointer. This bit field contains 54<sub>H</sub>, the address for the 1<sup>st</sup> Capabilities register set, the PCI Power Management Capability.

## Max Latency – Min Grant – Interrupt Pin – Interrupt Line

Address Offset: 3C<sub>H</sub>  
Access Type: Read/Write  
Reset Value: 0x0000\_0100

31	30	29	28	27	26	25	24	23	22	21	20	19	18	17	16	15	14	13	12	11	10	09	08	07	06	05	04	03	02	01	00
Max Latency								Min Grant								Interrupt Pin								Interrupt Line							

This register defines various control functions associated with the PCI bus. The register bits are defined below.

- **Bit [31:24]:** Max Latency (R) – Maximum Latency. This bit field is hardwired to 00<sub>H</sub>.
- **Bit [23:16]:** Min Grant (R) – Minimum Grant. This bit field is hardwired to 00<sub>H</sub>.
- **Bit [15:08]:** Interrupt Pin (R) – Interrupt Pin Used. This bit field is hardwired to 01<sub>H</sub> to indicate that the SiI3132 uses the INTA interrupt. The INTB, INTC, and INTD interrupts may be used by enabling them in the Port Interrupt Enable registers; this use is outside the PCI specification.

- **Bit [07:00]:** Interrupt Line (R/W) – Interrupt Line. This bit field is used by the system to indicate interrupt line routing information. The SiI3132 does not use this information.

### Header Write Enable

Address Offset: 48<sub>H</sub>  
 Access Type: Read/Write  
 Reset Value: 0x0000\_0000

31	30	29	28	27	26	25	24	23	22	21	20	19	18	17	16	15	14	13	12	11	10	09	08	07	06	05	04	03	02	01	00
Reserved																Ind Acc Ena		Hdr Wr Ena													

- **Bit [31:02]:** Reserved (R). This bit field is reserved and returns zeros on a read.
- **Bit [01]:** Ind Acc Ena (R) – Indirect Access Enable. This bit enables the Indirect Access registers at offset F0<sub>H</sub>-FF<sub>H</sub>.
- **Bit [00]:** Hdr Wr Ena (R) – Header Write Enable. This bit enables writing to registers defined as read-only by the PCI specification. This bit is required to meet PCI compliance testing that expects certain registers to be read-only. This bit is set to enable write access to the following registers in the PCI Configuration Header: Device ID (03-02<sub>H</sub>), PCI Class Code (09-0B<sub>H</sub>), Subsystem Vendor ID (2D-2C<sub>H</sub>), and Subsystem ID (2F-2E<sub>H</sub>).

### Power Management Capability

Address Offset: 54<sub>H</sub>  
 Access Type: Read Only  
 Reset Value: 0x0622\_5C01

31	30	29	28	27	26	25	24	23	22	21	20	19	18	17	16	15	14	13	12	11	10	09	08	07	06	05	04	03	02	01	00
PME Support				PPM D2 Support		PPM D1 Support		Auxiliary Current			Dev Special Init		Reserved		PME Clock		PPM Rev			Next Capability Pointer						Capability ID					

This register defines the power management capabilities associated with the PCI bus. The register bits are defined below.

- **Bit [31:27]:** PME Support (R) – Power Management Event Support. This bit field is hardwired to 00<sub>H</sub>; the SiI3132 does not support PME.
- **Bit [26]:** PPM D2 Support (R) – PCI Power Management D2 Support. This bit is hardwired to 1.
- **Bit [25]:** PPM D1 Support (R) – PCI Power Management D1 Support. This bit is hardwired to 1.
- **Bit [24:22]:** Auxiliary Current (R) – Auxiliary Current. This bit field is hardwired to 000<sub>B</sub>.
- **Bit [21]:** Dev Special Init (R) – Device Special Initialization. This bit is hardwired to 1 to indicate that the SiI3132 requires special initialization.
- **Bit [20]:** Reserved (R). This bit is reserved and returns zero on a read.
- **Bit [19]:** PME Clock (R) – Power Management Event Clock. This bit is hardwired to 0.
- **Bit [18:16]:** PPM Rev (R) – PCI Power Management Revision. This bit field is hardwired to 010<sub>B</sub> to indicate compliance with the PCI Power Management Interface Specification revision 1.1.
- **Bit [15:08]:** Next Capability Pointer (R) – PCI Next Capability Pointer. This bit field is hardwired to 5C<sub>H</sub> to point to the 2<sup>nd</sup> Capabilities register, the MSI Capability.
- **Bit [07:00]:** Capability ID (R) – PCI Capability ID. This bit field is hardwired to 01<sub>H</sub> to indicate that this is a PCI Power Management Capability.

## Power Management Control + Status

Address Offset: 58<sub>H</sub>  
Access Type: Read/Write  
Reset Value: 0x0C00\_2000

31	30	29	28	27	26	25	24	23	22	21	20	19	18	17	16	15	14	13	12	11	10	09	08	07	06	05	04	03	02	01	00
PPM Data								Reserved								PME Status	PPM Data Scale	PPM Data Sel			PME Ena	Reserved						PPM Power State			

This register defines the power management capabilities associated with the PCI bus. The register bits are defined below.

- **Bit [31:24]:** PPM Data (R) – PCI Power Management Data. This bit field is hardwired to 0x0C to indicate a power consumption of 1.2 Watt.
- **Bit [23:16]:** Reserved (R). This bit field is reserved and returns zeros on a read.
- **Bit [15]:** PME Status (R) – PME Status. This bit is hardwired to 0. The SiI3132 does not support PME.
- **Bit [14:13]:** PPM Data Scale (R) – PCI Power Management Data Scale. This bit field is hardwired to 01<sub>B</sub> to indicate a scaling factor of 100 mW.
- **Bit [12:09]:** PPM Data Sel (R/W) – PCI Power Management Data Select. This bit field is set by the system to indicate which data field is to be reported through the PPM Data bits (although current implementation hardwires the PPM Data to indicate 1.2 Watt).
- **Bit [08]:** PME Ena (R) – PME Enable. This bit is hardwired to 0. The SiI3132 does not support PME.
- **Bit [07:02]:** Reserved (R). This bit field is reserved and returns zeros on a read.
- **Bit [01:00]:** PPM Power State (R/W) – PCI Power Management Power State. This bit field is set by the system to dictate the current Power State: 00 = D0 (Normal Operation), 01 = D1, 10 = D2, and 11 = D3 (Hot).

## MSI Capability

Address Offset: 5C<sub>H</sub>  
Access Type: Read/Write  
Reset Value: 0x0080\_7005

31	30	29	28	27	26	25	24	23	22	21	20	19	18	17	16	15	14	13	12	11	10	09	08	07	06	05	04	03	02	01	00
Reserved								64-bit Addr	Multiple Message Enable	Multiple Message Capable	MSI Enable	Next Capability Pointer						Capability ID													

This register defines the MSI Capability Message Control. The register bits are defined below.

- **Bit [31:24]:** Reserved (R) – This bit field is reserved and returns zeros on a read.
- **Bit [23]:** 64-bit Addr (R) – 64-bit Address Capable. This bit is hardwired to 1.
- **Bit [22:20]:** Multiple Message Enable (R/W) – This bit field defaults to 000<sub>B</sub>.
- **Bit [19:17]:** Multiple Message Capable (R/W) – This bit field defaults to 000<sub>B</sub>.
- **Bit [16]:** MSI Enable (R/W) – This bit is set to enable Message Signaled Interrupts.
- **Bit [15:08]:** Next Capability Pointer (R) – Next Capability Pointer. This bit field is hardwired to 70<sub>H</sub> to point to the 3<sup>rd</sup> Capabilities register, the PCI Express Capability.
- **Bit [07:00]:** Capability ID (R) – This bit field is hardwired to 05<sub>H</sub> to indicate that this is a MSI Capability.

## Message Address

Address Offset: 60<sub>H</sub>-67<sub>H</sub>

Access Type: Read/Write

Reset Value: 0x0000\_0000\_0000\_0000

63	62	61	60	59	58	57	56	55	54	53	52	51	50	49	48	47	46	45	44	43	42	41	40	39	38	37	36	35	34	33	32
Message Address Upper																															
31	30	29	28	27	26	25	24	23	22	21	20	19	18	17	16	15	14	13	12	11	10	09	08	07	06	05	04	03	02	01	00
Message Address																															00

This register specifies the memory address for an MSI memory write transaction. The memory address must be of a dword (bits 1:0 must be 0).

## MSI Message Data

Address Offset: 68<sub>H</sub>

Access Type: Read/Write

Reset Value: 0x0000\_0000

31	30	29	28	27	26	25	24	23	22	21	20	19	18	17	16	15	14	13	12	11	10	09	08	07	06	05	04	03	02	01	00
Reserved																Message Data															

This register specifies the MSI Message Data. The register bits are defined below.

- **Bit [31:16]:** Reserved (R) – This bit field is reserved and returns zeros on a read.
- **Bit [15:00]:** Message Data (R/W) – This bit field specifies the Message Data for an MSI memory write transaction.

## PCI Express Capability

Address Offset: 70<sub>H</sub>

Access Type: Read Only

Reset Value: 0x0011\_0010

31	30	29	28	27	26	25	24	23	22	21	20	19	18	17	16	15	14	13	12	11	10	09	08	07	06	05	04	03	02	01	00
Reserved	Interrupt Message Number					Reserved	Device Type					Version					Next Capability Pointer					Capability ID									

- **Bit [31:30,24]:** Reserved (R) – These bits are reserved and return zero on a read.
- **Bit [29:25]:** Interrupt Message Number (R) – This bit field is hardwired to 0.
- **Bit [23:20]:** Device Type (R) – This bit field is hardwired to 0001<sub>B</sub> to indicate a PCI Express Legacy Endpoint device.
- **Bit [19:16]:** Version (R) – This bit field is hardwired to 01<sub>H</sub> to indicate compliance with the PCI Express Specification revision 1.0a.
- **Bit [15:08]:** Next Capability Pointer (R) – PCI Next Capability Pointer. This bit field is hardwired to 00<sub>H</sub> (this is the last capability).

- **Bit [07:00]:** Capability ID (R) – PCI Capability ID. This bit field is hardwired to 10<sub>H</sub> to indicate that this is a PCI Express Capability.

## Device Capabilities

Address Offset: 74<sub>H</sub>

Access Type: Read Only

Reset Value: 0x0000\_0003

31	30	29	28	27	26	25	24	23	22	21	20	19	18	17	16	15	14	13	12	11	10	09	08	07	06	05	04	03	02	01	00
Reserved				Slot Power								Reserved			Pwr Indicator	Atten Indicator	Atten Button	L1 Latency			L0s Latency		Ext Tag Sup	Phantom Functions		Max Payload					

- **Bit [31:28,17:15]:** Reserved (R) – These bits are reserved and return zero on a read.
- **Bit [27:18]:** Slot Power (R) – Captured Slot Power Limit Value and Limit Scale. This bit field is hardwired to 0.
- **Bit [14]:** Pwr Indicator (R) – Power Indicator Present. This bit field is hardwired to 0.
- **Bit [13]:** Atten Indicator (R) – Attention Indicator Present. This bit field is hardwired to 0.
- **Bit [12]:** Atten Button (R) – Attention Button Present. This bit field is hardwired to 0.
- **Bit [11:09]:** L1 Latency (R) – This bit field is hardwired to 000<sub>B</sub>.
- **Bit [08:06]:** L0s Latency (R) – This bit field is hardwired to 000<sub>B</sub>.
- **Bit [05]:** Ext Tag Sup (R) – Extended Tag Field Supported. This bit is hardwired to 0.
- **Bit [04:03]:** Phantom Functions (R) – This bit field is hardwired to 0.
- **Bit [02:00]:** Max Payload (R) – Max\_Payload\_Size Supported. This bit field is hardwired to 011<sub>B</sub> to indicate that a maximum 1024-byte payload is supported.

## Device Status and Control

Address Offset: 78<sub>H</sub>

Access Type: Read/Write/Write 1 to Clear

Reset Value: 0x0000\_2000

31	30	29	28	27	26	25	24	23	22	21	20	19	18	17	16	15	14	13	12	11	10	09	08	07	06	05	04	03	02	01	00
Reserved										Trans Pending	AUX Power	Unsup Req Det	Fatal Error Det	Non-Fatal Error	Corr Error Det	Reserved	Max Read Request Size		EnSnp Not Req	Aux Pwr PM En	Phntm Fnc En	Ext Tag Fld En	Max Payload Size		En Rixd Ord	Unsup Req Rep En	Fatal Err Rep En	NonFtl Err Rep En	Corr Err Rep En		

- **Bit [31:22,15]:** Reserved (R) – These bits are reserved and return zero on a read.
- **Bit [21]:** Trans Pending (R) – Transactions Pending.
- **Bit [20]:** AUX Power (R) – AUX Power Detected. This bit is hardwired to 0.
- **Bit [19]:** Unsup Req Det (R/W1C) – Unsupported Request Detected.
- **Bit [18]:** Fatal Error Det (R/W1C) – Fatal Error Detected.
- **Bit [17]:** Non-Fatal Error (R/W1C) – Non-Fatal Error Detected.
- **Bit [16]:** Corr Error Det (R/W1C) – Correctable Error Detected.
- **Bit [14:12]:** Max Read Request Size (R/W) – Allowable values are 000<sub>B</sub> to 011<sub>B</sub> (128 to 1024 bytes). Default is 010<sub>B</sub> (512 bytes).
- **Bit [11]:** EnSnp Not Req (R) – Enable No Snoop. This bit is hardwired to 0.
- **Bit [10]:** Aux Pwr PM En (R) – Auxiliary Power PM Enable. This bit is hardwired to 0.
- **Bit [09]:** Phntm Fnc En (R) – Phantom Functions Enable. This bit is hardwired to 0.
- **Bit [08]:** Ext Tag Fld En (R) – Extended Tag Field Enable. This bit is hardwired to 0.
- **Bit [07:05]:** Max Payload Size (R/W) – Allowable values are 000<sub>B</sub> to 011<sub>B</sub> (128 to 1024 bytes). Default is 000<sub>B</sub> (128 bytes).

- **Bit [04]:** En Rlxd Ord (R) – Enable Relaxed Ordering. This bit field is hardwired to 0.
- **Bit [03]:** UnsReq Rep En (R/W) – Unsupported Request Reporting Enable.
- **Bit [02]:** Fatal Err Rep En (R/W) – Fatal Error Reporting Enable.
- **Bit [01]:** NonFtl Err Rep En (R/W) – Non-Fatal Error Reporting Enable.
- **Bit [00]:** Corr Err Rep En (R/W) – Correctable Error Reporting Enable.

## Link Capabilities

Address Offset: 7C<sub>H</sub>  
Access Type: Read Only  
Reset Value: 0x0000\_7411

31	30	29	28	27	26	25	24	23	22	21	20	19	18	17	16	15	14	13	12	11	10	09	08	07	06	05	04	03	02	01	00
Port Number								Reserved								L1 Exit Latency		L0s Exit Latency		ASPM Support		Maximum Link Width				Maximum Link Speed					

- **Bit [31:24]:** Port Number (R) – This bit field is hardwired to 00<sub>H</sub>.
- **Bit [23:18]:** Reserved (R) – These bits are reserved and return zero on a read.
- **Bit [17:15]:** L1 Exit Latency (R) – This bit field is hardwired to 000<sub>B</sub>.
- **Bit [14:12]:** L0s Exit Latency (R) – This bit field is hardwired to 111<sub>B</sub>.
- **Bit [11:10]:** ASPM Support (R) – This bit field is hardwired to 01<sub>B</sub>.
- **Bit [09:04]:** Maximum Link Width (R) – This bit field is hardwired to 000001<sub>B</sub>.
- **Bit [03:00]:** Maximum Link Speed (R) – This bit field is hardwired to 0001<sub>B</sub>.

## Link Status and Control

Address Offset: 80<sub>H</sub>  
Access Type: Read/Write  
Reset Value: 0x0011\_0000 or 0x1011\_0000

31	30	29	28	27	26	25	24	23	22	21	20	19	18	17	16	15	14	13	12	11	10	09	08	07	06	05	04	03	02	01	00
Reserved			Slot Clk Config	Link Training	Link Train Err	Negotiated Link Width						Link Speed				Reserved						Ext Synch	Comm Clk Cfg	Retrain Link	Link Disable	RCB	Reserved	ASPM Control			

- **Bit [31:29,15:08,02]:** Reserved (R) – These bits are reserved and return zero on a read.
- **Bit [28]:** Slot Clk Config (R) – Slot Clock Configuration. This bit is 1 if the reference clock is detected.
- **Bit [27]:** Link Training (R) – This bit is hardwired to 0.
- **Bit [26]:** Link Train Err (R) – This bit is hardwired to 0.
- **Bit [25:20]:** Negotiated Link Width (R) – This bit field is hardwired to 000001<sub>B</sub>.
- **Bit [19:16]:** Link Speed (R) – This bit field is hardwired to 0001<sub>B</sub>.
- **Bit [07]:** Ext Synch (R/W) – Extended Synch.
- **Bit [06]:** Comm Clk Cfg (R/W) – Common Clock Configuration.
- **Bit [05]:** Retrain Link (R) – This bit is hardwired to 0.
- **Bit [04]:** Link Disable (R) – This bit is hardwired to 0.
- **Bit [03]:** RCB (R/W) – Read Completion Boundary.
- **Bit [01:00]:** ASPM Control (R/W)



### Global Register Offset

Address Offset: F0<sub>H</sub>  
Access Type: Read/Write  
Reset Value: 0x0000\_0000

31	30	29	28	27	26	25	24	23	22	21	20	19	18	17	16	15	14	13	12	11	10	09	08	07	06	05	04	03	02	01	00
Reserved																								Dword Offset			00				

This register provides indirect addressing of a Global Register otherwise accessible directly via Base Address Register 0. The dword address offset for an indirect access is in bits 6 to 2; bits 31 to 7, 1, and 0 are reserved and should always be 0.

Note that this is physically the same register as that addressed by Base Address Register 2, Offset 00<sub>H</sub>.

### Global Register Data

Address Offset: F4<sub>H</sub>  
Access Type: Read/Write

31	30	29	28	27	26	25	24	23	22	21	20	19	18	17	16	15	14	13	12	11	10	09	08	07	06	05	04	03	02	01	00
As defined for indirectly accessed register																															

This register provides the indirect access addressed by the Global Register Offset register.

### Port Register Offset

Address Offset: F8<sub>H</sub>  
Access Type: Read/Write  
Reset Value: 0x0000\_0000

31	30	29	28	27	26	25	24	23	22	21	20	19	18	17	16	15	14	13	12	11	10	09	08	07	06	05	04	03	02	01	00
Reserved													Dword Offset													00					

This register provides indirect addressing of a Port Register otherwise accessible directly via Base Address Register 1. The dword address offset for an indirect access is in bits 13 to 2; bits 31 to 14, 1, and 0 are reserved and should always be 0.

Note that this is physically the same register as that addressed by Base Address Register 2, Offset 08<sub>H</sub>.

### Port Register Data

Address Offset: FC<sub>H</sub>  
Access Type: Read/Write

31	30	29	28	27	26	25	24	23	22	21	20	19	18	17	16	15	14	13	12	11	10	09	08	07	06	05	04	03	02	01	00
As defined for indirectly accessed register																															

This register provides the indirect access addressed by the Port Register Offset register.

## Advanced Error Reporting Capability

Address Offset: 100<sub>H</sub>  
Access Type: Read Only  
Reset Value: 0x0001\_0001

31	30	29	28	27	26	25	24	23	22	21	20	19	18	17	16	15	14	13	12	11	10	09	08	07	06	05	04	03	02	01	00
Next Capability Pointer												Version				Extended Capability ID															

- **Bit [31:20]:** Next Capability Pointer (R) – PCI Next Capability Pointer. This bit field is hardwired to 000<sub>H</sub> (this is the last capability).
- **Bit [19:16]:** Version (R) – This bit field is hardwired to 01<sub>H</sub> to indicate compliance with the PCI Express Specification revision 1.0a.
- **Bit [15:00]:** Extended Capability ID (R) – PCI Capability ID. This bit field is hardwired to 0001<sub>H</sub> to indicate that this is an Advanced Error Reporting Capability.

## Uncorrectable Error Status

Address Offset: 104<sub>H</sub>  
Access Type: Read/Write 1 to Clear  
Reset Value: 0x0000\_0000

31	30	29	28	27	26	25	24	23	22	21	20	19	18	17	16	15	14	13	12	11	10	09	08	07	06	05	04	03	02	01	00
Reserved											Unsup Req Err	ECRC Error	Malformed TLP	Rx Overflow (0)	Unexp Comp	Comp Abort	Comp Timeout	FC Protocol Err	Poisoned TLP	Reserved						DL Protocol Err	Reserved		Training Error		

- **Bit [31:21,11:05,03:01]:** Reserved (R) – These bits are reserved and return zero on a read.
- **Bit [20]:** Unsup Req Err (R/W1C) – Unsupported Request Error Status.
- **Bit [19]:** ECRC Error (R/W1C) – ECRC Error Status.
- **Bit [18]:** Malformed TLP (R/W1C) – Malformed TLP Status.
- **Bit [17]:** Rx Overflow (R) – Receiver Overflow Status; always 0.
- **Bit [16]:** Unexp Comp (R/W1C) – Unexpected Completion Status.
- **Bit [15]:** Comp Abort (R/W1C) – Completer Abort Status.
- **Bit [14]:** Comp Timeout (R/W1C) – Completion Timeout Status.
- **Bit [13]:** FC Protocol Err (R/W1C) – Flow Control Protocol Error Status. This bit is hardwired to 0 (as are its mask and error severity bits).
- **Bit [12]:** Poisoned TLP (R/W1C) – Poisoned TLP Status.
- **Bit [04]:** DL Protocol Err (R/W1C) – Data Link Protocol Error Status.
- **Bit [00]:** Training Error (R) – This bit is hardwired to 0 (as are its mask and error severity bits).

## Uncorrectable Error Mask

Address Offset: 108<sub>H</sub>  
Access Type: Read/Write  
Reset Value: 0x0000\_0000

31	30	29	28	27	26	25	24	23	22	21	20	19	18	17	16	15	14	13	12	11	10	09	08	07	06	05	04	03	02	01	00
Reserved											Unsup Req Err	ECRC Error	Malformed TLP	Rx Overflow (0)	Unexp Comp	Comp Abort	Comp Timeout	FC Protocol Err	Poisoned TLP	Reserved							DL Protocol Err	Reserved		Training Error	

The bits of this register are the mask bits for corresponding bits of the Uncorrectable Error Status register.

## Uncorrectable Error Severity

Address Offset: 10C<sub>H</sub>  
Access Type: Read/Write  
Reset Value: 0x0004\_0010

31	30	29	28	27	26	25	24	23	22	21	20	19	18	17	16	15	14	13	12	11	10	09	08	07	06	05	04	03	02	01	00
Reserved											Unsup Req Err	ECRC Error	Malformed TLP	Rx Overflow (0)	Unexp Comp	Comp Abort	Comp Timeout	FC Protocol Err	Poisoned TLP	Reserved							DL Protocol Err	Reserved		Training Error	

The bits of this register are the error severity bits for corresponding bits of the Uncorrectable Error Status register.

## Correctable Error Status

Address Offset: 110<sub>H</sub>  
Access Type: Read/Write 1 to Clear  
Reset Value: 0x0000\_0000

31	30	29	28	27	26	25	24	23	22	21	20	19	18	17	16	15	14	13	12	11	10	09	08	07	06	05	04	03	02	01	00
Reserved											Replay Timeout	Reserved			REPLAY_NUM	Bad DLLP	Bad TLP	Reserved							Rx Error						

- **Bit [31:13,11:09,05:01]:** Reserved (R) – These bits are reserved and return zero on a read.
- **Bit [12]:** Replay Timeout (R/W1C) – Replay Timer Timeout Status.
- **Bit [08]:** REPLAY\_NUM (R/W1C) – REPLAY\_NUM Rollover Status.
- **Bit [07]:** Bad DLLP (R/W1C) – Bad DLLP Status.
- **Bit [06]:** Bad TLP (R/W1C) – Bad TLP Status.
- **Bit [00]:** Rx Error (R/W1C) – Receiver Error Status. This bit is hardwired to 0 (as is the corresponding mask bit).

### Correctable Error Mask

Address Offset: 114<sub>H</sub>  
Access Type: Read/Write  
Reset Value: 0x0000\_0000

31	30	29	28	27	26	25	24	23	22	21	20	19	18	17	16	15	14	13	12	11	10	09	08	07	06	05	04	03	02	01	00
Reserved																			Replay Timeout	Reserved			REPLAY_NUM	Bad DLLP	Bad TLP	Reserved					Rx Error

The bits of this register are the mask bits for corresponding bits of the Correctable Error Status register.

### Advanced Error Capabilities and Control

Address Offset: 118<sub>H</sub>  
Access Type: Read/Write  
Reset Value: 0x0000\_00A0

31	30	29	28	27	26	25	24	23	22	21	20	19	18	17	16	15	14	13	12	11	10	09	08	07	06	05	04	03	02	01	00						
Reserved																							ECRC Chk En	ECRC Chk Cap	ECRC Gen En	ECRC Gen Cap	First Error Pointer										

- **Bit [31: 09]:** Reserved (R) – These bits are reserved and return zero on a read.
- **Bit [08]:** ECRC Chk En (R/W) – ECRC Check Enable.
- **Bit [07]:** ECRC Chk Cap (R) – ECRC Check Capable. This bit is hardwired to 1.
- **Bit [06]:** ECRC Gen En (R/W) – ECRC Generation Enable.
- **Bit [05]:** ECRC Gen Cap (R) – ECRC Generation Capable. This bit is hardwired to 1.
- **Bit [04:00]:** First Error Pointer (R).

## Header Log

Address Offset: 11C<sub>H</sub> / 120<sub>H</sub> / 124<sub>H</sub> / 128<sub>H</sub>

Access Type: Read Only

Reset Value: 0x0000\_0000

31	30	29	28	27	26	25	24	23	22	21	20	19	18	17	16	15	14	13	12	11	10	09	08	07	06	05	04	03	02	01	00
Header Log (1st dword)																															
Header Byte 0								Header Byte 1								Header Byte 2								Header Byte 3							
Header Log (2nd dword)																															
Header Byte 4								Header Byte 5								Header Byte 6								Header Byte 7							
Header Log (3rd dword)																															
Header Byte 8								Header Byte 9								Header Byte 10								Header Byte 11							
Header Log (4th dword)																															
Header Byte 12								Header Byte 13								Header Byte 14								Header Byte 15							

This 16-byte register contains the header of a TLP associated with an error.

## Internal Register Space – Base Address 0

These registers are 32 or 64 bits wide and are the Global Registers of the Sil3132. Access to this register space is through the PCI Memory space.

**Table 38. Sil3132 Internal Register Space – Base Address 0**

Address Offset	Register Name	
00 <sub>H</sub>	Port 0 Slot Status	
04 <sub>H</sub>	Port 1 Slot Status	
08 <sub>H</sub> -3F <sub>H</sub>	Reserved	
40 <sub>H</sub>	Global Control	
44 <sub>H</sub>	Global Interrupt Status	
48 <sub>H</sub>	PHY Configuration	
4C <sub>H</sub> -5F <sub>H</sub>	Reserved	
60 <sub>H</sub>	I <sup>2</sup> C Control	
64 <sub>H</sub>	I <sup>2</sup> C Status	
68 <sub>H</sub>	I <sup>2</sup> C Slave Address	
6C <sub>H</sub>	I <sup>2</sup> C Data Buffer	
70 <sub>H</sub>	Flash Address	
74 <sub>H</sub>	GPIO	Flash Data
78 <sub>H</sub> -7F <sub>H</sub>	Reserved	

### Port Slot Status Registers

Address Offset: 00<sub>H</sub>-07<sub>H</sub>

Access Type: Read

Reset Value: 0x0000\_0000

	31	30	29	28	27	26	25	24	23	22	21	20	19	18	17	16	15	14	13	12	11	10	09	08	07	06	05	04	03	02	01	00
Attention	Slot Status																															

These 2 registers provide the Status for the 31 Command Slots for each of the 2 ports. These registers also appear in Port register space. Reading this register will clear the Command Completion Status for the port if the Interrupt No Clear on Read bit (bit 3) of the Port Control register is 0. The register bits are defined below.

- **Bit [31]:** Attention (R) – This bit indicates that something occurred in the corresponding port that requires the attention of the host. Other port registers must be examined to determine the origin of the error. This bit is the logical OR of the masked interrupt conditions, except for Command Completion, reported in the Port Interrupt Status register.
- **Bit [30:0]:** Slot Status (R) – These bits are the Active status bits corresponding to Slot numbers 30 to 0. The Active status bit for a slot is set when the Slot number is written to the Command Execution FIFO (direct command transfer method) or when a Command Activation register is written (indirect command transfer method).

## Global Control

Address Offset: 40<sub>H</sub>  
Access Type: Read/Write  
Reset Value: 0x8100\_0000

31	30	29	28	27	26	25	24	23	22	21	20	19	18	17	16	15	14	13	12	11	10	09	08	07	06	05	04	03	02	01	00
Global Reset	MSIACK	I <sup>2</sup> C Int Enable	Reserved				3Gb/s Capable	Reserved														Port 1 Int Enable	Port 0 Int Enable								

This register controls various functions of the chip.

- **Bit [31]:** Global Reset (R/W). This bit, when set to one, asserts a port reset to all ports. This bit must be cleared to zero to allow normal operation. Once set by this bit, all port resets will remain set to one until explicitly cleared to zero through the individual port control clear registers. Refer to the port control set register description for more information.
- **Bit [30]:** MSI Acknowledge (W). Writing a one to this bit acknowledges a Message Signaled Interrupt and permits generation of another MSI. This bit is cleared immediately after the acknowledgement is recognized by the control logic, hence the bit will always be read as a zero. If all interrupt conditions are removed subsequent to an MSI, it is not necessary to assert this Acknowledge; another MSI will be generated when an interrupt condition occurs.
- **Bit [29]:** I<sup>2</sup>C Int Enable (R/W). This bit, when set to one, allows assertion of an interrupt when the I<sup>2</sup>C interrupt is asserted. When set to zero, the interrupt is masked.
- **Bit [28:25,23:2]:** Reserved (R). These bits are reserved and will return zeroes when read.
- **Bit [24]:** 3Gb/s Capable (R). This bit is hardwired to one.
- **Bit [1:0]:** Port Interrupt Enable (R/W). These bits, when set to one, allow assertion of an interrupt when the corresponding port asserts an interrupt. When set to zero, the corresponding port interrupts are masked.

## Global Interrupt Status

Address Offset: 44<sub>H</sub>  
Access Type: Read/Write 1 Clear  
Reset Value: 0x0000\_0000

31	30	29	28	27	26	25	24	23	22	21	20	19	18	17	16	15	14	13	12	11	10	09	08	07	06	05	04	03	02	01	00
Reserved		I <sup>2</sup> C Interrupt	Reserved														Port 1 Interrupt	Port 0 Interrupt													

This register is used to determine the status of various chip functions.

- **Bit [31:30]:** Reserved (R). This bit field is reserved and returns zeroes when read.
- **Bit [29]:** I<sup>2</sup>C Interrupt (R). This bit indicates that the I<sup>2</sup>C Interrupt is pending. The interrupt source must be cleared (in the I<sup>2</sup>C Status register) for this bit to be zero. This bit will not report interrupt sources that are not enabled in the I<sup>2</sup>C Control register.
- **Bit [28:2]:** Reserved (R). This bit field is reserved and returns zeroes when read.
- **Bit [1:0]:** Port Interrupt Status (R/W1C). These bits, when set to one, indicate that the corresponding port has an interrupt condition pending. Writing a 1 to any of these bits clears the corresponding Command Completion Interrupt Status, but not other interrupt sources.

## PHY Configuration

Address Offset: 48<sub>H</sub>  
Access Type: Read/Write  
Reset Value: 0x0000\_2C40

31	30	29	28	27	26	25	24	23	22	21	20	19	18	17	16	15	14	13	12	11	10	09	08	07	06	05	04	03	02	01	00
Reserved																PHY Config															

This register is reset to 0x00002C40.

- **Bit [31:16]:** Reserved (R/W) – This bit field is reserved and must be always zeros.
- **Bit [15:04]:** PHY Configuration (R/W) – These bits should not be changed from their defaults as erratic operation may result.
- **Bit [03:00]:** SATA SSC (R/W) – If this bit field set to 1111b, all channel Tx outputs Spread Spectrum Clocking.

## BIST Control Register

Address Offset: 50<sub>H</sub>  
Access Type: Read/Write  
Reset Value: 0x0000\_0000

31	30	29	28	27	26	25	24	23	22	21	20	19	18	17	16	15	14	13	12	11	10	09	08	07	06	05	04	03	02	01	00
BISTenable	BISTpatsel	Reserved												BISTcompse	Reserved												BISTrun				

This register is used to control Data Loopback BIST.

- **Bit [31]:** BISTenable (R/W) – This bit enables the data paths for running data loopback BIST.
- **Bit [30]:** BISTpatsel (R/W) – This bit selects whether a repeating pattern (supplied from the BIST Pattern register) or a pseudorandom pattern is used for running data loopback BIST. Setting the bit to 1 selects the repeating pattern.
- **Bit [29:18]:** Reserved (R/W). These bits are reserved and must write zeros.
- **Bit [17:16]:** BISTcompse (R/W). This bit field selects the port from which loopback data is selected for pattern comparison.
- **Bit [15:04]:** Reserved (R/W). These bits are reserved and must write zeros.
- **Bit [03:00]:** BISTrun (R/W). This bit field selects the port(s) that transmit loopback data.



## BIST Pattern Register

Address Offset: 54<sub>H</sub>  
Access Type: Read/Write  
Reset Value: 0x0000\_0000

31	30	29	28	27	26	25	24	23	22	21	20	19	18	17	16	15	14	13	12	11	10	09	08	07	06	05	04	03	02	01	00
BIST Pattern																															

This register contains the 32-bit fixed pattern that is repeatedly transmitted in data loopback when the BISTpatsel bit (bit 30) of the BIST Control register is set to 1.

## BIST Status Register

Address Offset: 58<sub>H</sub>  
Access Type: Read  
Reset Value: 0x8000\_0000

31	30	29	28	27	26	25	24	23	22	21	20	19	18	17	16	15	14	13	12	11	10	09	08	07	06	05	04	03	02	01	00
BISTgood	Reserved																BISTerrcnt														

- **Bit [31]:** BISTgood (R) – This bit indicates that all comparisons have been good since initiating data loopback BIST. This bit is initialized (to 1) when the BISTenable bit is zero in the BIST Control register.
- **Bit [30:12]:** Reserved (R). This bit field is reserved and returns zeros on a read.
- **Bit [11:00]:** BISTerrcnt (R). This bit field indicates the number of comparisons that have been in error since initiation of data loopback BIST. This counter is a saturating counter (it stops counting at 0FFF<sub>H</sub>). This counter is cleared when the BISTenable bit is zero in the BIST Control register.

## I<sup>2</sup>C Control

Address Offset: 60<sub>H</sub>  
Access Type: Read/Write  
Reset Value: 0x0000\_0000

31	30	29	28	27	26	25	24	23	22	21	20	19	18	17	16	15	14	13	12	11	10	09	08	07	06	05	04	03	02	01	00
Reserved																Fast Mode	Unit Reset	Addr Det Int En	Arb Loss Det Int En	STOP Det Int En	Bus Error Int En	Rx Full Int En	Tx MT Int En	Gen Call Disable	Unit Enable	SCL Enable	Master Abort	Transfer Byte	ACK/NACK Ctrl	STOP	START

This register contains bits to control the operation of the I<sup>2</sup>C interface.

- **Bit [31:16]:** Reserved (R). This bit field is reserved and returns zeros on a read.
- **Bit [15]:** Fast Mode (R/W). This bit, when set, enables 400 kbit/s operation (instead of 100 kbit/s)
- **Bit [14]:** Unit Reset (R/W). This bit, when set, resets the I<sup>2</sup>C controller.
- **Bit [13]:** Addr Det Int En (R/W). Slave Address Detected Interrupt Enable – This bit enables interrupt generation upon the detection of the Slave Address or the General Call Address.
- **Bit [12]:** Arb Loss Det Int En (R/W). Arbitration Loss Detected Interrupt Enable – This bit enables interrupt generation upon losing arbitration in Master Mode. If this bit is not set, and arbitration is lost during transmission of the control byte, the arbitration and transmission will be automatically repeated.

- **Bit [11]:** STOP Det Int En (R/W). Slave STOP Detected Interrupt Enable – This bit enables interrupt generation upon detection of a STOP condition while in Slave Mode.
- **Bit [10]:** Bus Error Int En (R/W). Bus Error Interrupt Enable – This bit enables interrupt generation upon detection of an I<sup>2</sup>C error.
- **Bit [09]:** Rx Full Int En (R/W). Receive Buffer Full Interrupt Enable – This bit enables interrupt generation when a byte has been received and is in the I<sup>2</sup>C Data Buffer register.
- **Bit [08]:** Tx MT Int En (R/W). Transmit Buffer Empty Interrupt Enable – This bit enables interrupt generation after the data byte in the I<sup>2</sup>C Data Buffer register has been transmitted.
- **Bit [07]:** Gen Call Disable (R/W). General Call Disable – This bit disables detection of a General Call Address.
- **Bit [06]:** Unit Enable (R/W). This bit must be set to enable any I<sup>2</sup>C controller operations.
- **Bit [05]:** SCL Enable (R/W). This bit must be set to enable the I<sup>2</sup>C Clock output for Master Mode operations.
- **Bit [04]:** Master Abort (R/W). This bit may be set along with STOP to send a STOP without first transferring a byte.
- **Bit [03]:** Transfer Byte (R/W). Set to initiate the transfer to/from the Data Buffer.
- **Bit [02]:** ACK/NACK Ctrl (R/W). Set to send a NACK instead of an ACK after receiving a data byte. Note that an ACK will be sent in response to slave address detection regardless of this bit. Sending a NACK in Slave Mode will set the Bus Error status.
- **Bit [01]:** STOP (R/W). Set to send a STOP following transfer of a byte (using Transfer Byte) or immediately (using Master Abort).
- **Bit [00]:** START (R/W). Set to send a START prior to transfer of a byte (using Transfer Byte).

## I<sup>2</sup>C Status

Address Offset: 64<sub>H</sub>

Access Type: Read/Write 1 to Clear

Reset Value: 0x0000\_0000

31	30	29	28	27	26	25	24	23	22	21	20	19	18	17	16	15	14	13	12	11	10	09	08	07	06	05	04	03	02	01	00
Reserved																					Bus Error Det	Slave Addr Det	Gen Call Det	Rx Full	Tx MT	Arb Loss Det	STOP Det	Bus Busy	Unit Busy	ACK/NACK Status	Read/Write

This register contains bits to report the status of the I<sup>2</sup>C interface.

- **Bit [31:11]:** Reserved (R). This bit field is reserved and returns zeros on a read.
- **Bit [10]:** Bus Error Det (R/W1C). Bus Error Detected – This bit reports the detection of an illegal NACK either received in Master Mode or sent in Slave Mode. This bit is not set by the legal NACK at the end of a transfer that signals the end to the slave.
- **Bit [09]:** Slave Addr Det (R/W1C). Slave Address Detected – This bit reports the detection of the Slave Address or of the General Call Address (when enabled). The byte received containing the address is placed into the I<sup>2</sup>C Data Buffer register.
- **Bit [08]:** Gen Call Det (R/W1C). General Call Address Detected – This bit reports the detection of the General Call Address.
- **Bit [07]:** Rx Full (R/W1C). I<sup>2</sup>C Data Buffer Receive Full – A data byte has been received and an ACK or NACK has been sent. This bit is set on the rising edge of the I<sup>2</sup>C clock allowing for some minimal (one bit) time for an interrupt before insertion of wait states.
- **Bit [06]:** Tx MT (R). I<sup>2</sup>C Data Buffer Transmit Empty – A data byte has been transmitted and an ACK or NACK has been received. This bit is set on the rising edge of the I<sup>2</sup>C clock allowing for some minimal (one bit) time for an interrupt before insertion of wait states.
- **Bit [05]:** Arb Loss Det (R/W1C). Arbitration Loss Detected – This bit indicates that arbitration has been lost. If the corresponding interrupt is not enabled, and the arbitration loss is detected during selection, i.e., during the control byte transmission, the arbitration will be repeated automatically; if arbitration is lost later during data transmission, no repeat is possible and is not attempted.

- **Bit [04]:** STOP Det (R/W1C). Slave STOP Detected.
- **Bit [03]:** Bus Busy (R). Indicates that the I<sup>2</sup>C bus is busy because of activity other than that generated by the I<sup>2</sup>C controller.
- **Bit [02]:** Unit Busy (R). Indicates that the I<sup>2</sup>C controller is busy.
- **Bit [01]:** ACK/NACK Status (R). Indicates status of last ACK or NACK sent or received.
- **Bit [00]:** Read/Write (R). Indicates state of the R/W# bit of the I<sup>2</sup>C slave address (either the one sent in Master Mode or the one received in Slave Mode).

### I<sup>2</sup>C Slave Address

Address Offset: 68<sub>H</sub>  
Access Type: Read/Write  
Reset Value: 0x0000\_0000

31	30	29	28	27	26	25	24	23	22	21	20	19	18	17	16	15	14	13	12	11	10	09	08	07	06	05	04	03	02	01	00
Reserved																								Slave Address							

This register contains the 7-bit Slave Address to which the I<sup>2</sup>C controller will respond.

### I<sup>2</sup>C Data Buffer

Address Offset: 6C<sub>H</sub>  
Access Type: Read/Write  
Reset Value: 0x0000\_0000

31	30	29	28	27	26	25	24	23	22	21	20	19	18	17	16	15	14	13	12	11	10	09	08	07	06	05	04	03	02	01	00
Reserved																								Data Buffer							

This register contains the buffer for I<sup>2</sup>C send/receive data.

### Flash Address

Address Offset: 70<sub>H</sub>  
Access Type: Read/Write  
Reset Value: 0xXXXX\_XXXX

31	30	29	28	27	26	25	24	23	22	21	20	19	18	17	16	15	14	13	12	11	10	09	08	07	06	05	04	03	02	01	00
GPIO Enable	Reserved '0001'				Mem Present	Mem Access Start	Mem Access Type	Reserved							Memory Address																

This register is the address and command/status register for the flash memory interface. The register bits are defined below.

- **Bit [31]:** GPIO Enable (R/W). This bit, when set to one, enables the use of the flash Data pins for General Purpose I/O.
- **Bit [30:27]:** Reserved (R). This bit field is reserved and returns '0001' on a read.
- **Bit [26]:** Mem Present (R) – Memory Present. This bit set indicates that the auto-initialization signature was read correctly from the flash Memory.

- **Bit [25]:** Mem Access Start (R/W) – Memory Access Start. This bit is set to initiate an operation to flash memory. This bit is self-clearing when the operation is complete.
- **Bit [24]:** Mem Access Type (R/W) – Memory Access Type. This bit is set to define a read operation from flash memory. This bit is cleared to define a write operation to flash memory.
- **Bit [23:19]:** Reserved (R). This bit field is reserved and returns zeros on a read.
- **Bit [18:00]:** Memory Address (R/W). This bit field is programmed with the address for a flash memory read or write access.

**Flash Memory Data / GPIO Control**

Address Offset: 74<sub>H</sub>  
 Access Type: Read/Write  
 Reset Value: 0x0000\_0000

31	30	29	28	27	26	25	24	23	22	21	20	19	18	17	16	15	14	13	12	11	10	09	08	07	06	05	04	03	02	01	00
Reserved								GPIO Control								Transition Detect								Memory Data							

This register contains the GPIO data/control fields and the flash memory data register.

- **Bit [31:24]:** Reserved (R). This bit field is reserved and returns zeros on a read.
- **Bit [23:16]:** GPIO Control (R/W). The bits of this field are written to control the output type for corresponding flash data lines; if a bit is a 1 the corresponding output is an open drain output (only driven low); if a 0 the corresponding output is always driven. To use a GPIO pin as an input, the control bit must be set to 1 (open-drain output) and the data bit must be set to 1 (undriven).
- **Bit [15:08]:** Transition Detect (R/C). The bits of this field report signal transition detection on the corresponding Flash data input; reading the register resets the transition detect bits.
- **Bit [07:00]:** Memory Data (R/W) – Flash Memory Data. This bit field is used for flash write data on a write operation, and returns the flash read data on a read operation. For GPIO, this field is used to write the GPIO output register and to read the GPIO input signals.

## Internal Register Space – Base Address 1

These registers are 32 bits wide and are the Port Registers and LRAM of the SiI3132. Access to these registers is through the PCI Memory space. Register descriptions that follow specify the address offset for Port 0; Port 1 registers are at the Port 0 offset plus 2000<sub>H</sub>.

**Table 39. SiI3132 Internal Register Space – Base Address 1**

Address Offset	Register Name
000 <sub>H</sub> -F7F <sub>H</sub>	Port 0 LRAM Slots
F80 <sub>H</sub> -FFF <sub>H</sub>	Port Multiplier Device Status/QActive Registers
1000 <sub>H</sub>	Write: Port 0 Control Set / Read: Port 0 Status
1004 <sub>H</sub>	Write: Port 0 Control Clear
1008 <sub>H</sub>	Port 0 Interrupt Status
100C <sub>H</sub>	Reserved
1010 <sub>H</sub>	Port 0 Interrupt Enable Set
1014 <sub>H</sub>	Port 0 Interrupt Enable Clear
1018 <sub>H</sub>	Reserved
101C <sub>H</sub>	32-bit Activation Upper Address
1020 <sub>H</sub>	Port 0 Command Execution FIFO
1024 <sub>H</sub>	Port 0 Command Error
1028 <sub>H</sub>	Port 0 FIS Configuration
102C <sub>H</sub>	Port 0 PCI Exp Request FIFO Threshold
1030 <sub>H</sub> -103F <sub>H</sub>	Reserved
1040 <sub>H</sub>	Port 0 8B/10B Decode Error Counter
1044 <sub>H</sub>	Port 0 CRC Error Counter
1048 <sub>H</sub>	Port 0 Handshake Error Counter
104C <sub>H</sub>	Reserved
1050 <sub>H</sub>	Port PHY Configuration
1054 <sub>H</sub> -17FF <sub>H</sub>	Reserved
1800 <sub>H</sub>	Port 0 Slot Status
1804 <sub>H</sub> -1BFF <sub>H</sub>	Reserved
1C00 <sub>H</sub> -1CF7 <sub>H</sub>	Command Activation Registers
1CF8 <sub>H</sub> -1E03F <sub>H</sub>	Reserved
1E04 <sub>H</sub>	Port Context Register
1E08 <sub>H</sub> -1EFF <sub>H</sub>	Reserved
1F00 <sub>H</sub>	Port 0 SControl
1F04 <sub>H</sub>	Port 0 SStatus
1F08 <sub>H</sub>	Port 0 SError
1F0C <sub>H</sub>	Port 0 SActive (indirect location)
1F10 <sub>H</sub>	Port 0 SNotification
1F14 <sub>H</sub> -1FFF <sub>H</sub>	Reserved
2000 <sub>H</sub> -3FFF <sub>H</sub>	Port 1 Registers mapped as above

## Port LRAM

Address Offset: 000<sub>H</sub>-FFF<sub>H</sub>

Access Type: Read/Write

Reset Value: indeterminate

The Port LRAM consists of 31 Slots of 128 bytes each and a 32<sup>nd</sup> "Slot" used to hold 16 Port Multiplier Device Specific Registers.

**Table 40. Port LRAM layout**

Address Offset	Description
000 <sub>H</sub> -07F <sub>H</sub>	Slot 0
080 <sub>H</sub> -0FF <sub>H</sub>	Slot 1
100 <sub>H</sub> -17F <sub>H</sub>	Slot 2
180 <sub>H</sub> -EFF <sub>H</sub>	Slots 3-29
F00 <sub>H</sub> -F7F <sub>H</sub>	Slot 30
F80 <sub>H</sub> -F83 <sub>H</sub>	Port Multiplier Device 0 Status Register
F84 <sub>H</sub> -F87 <sub>H</sub>	Port Multiplier Device 0 QActive Register
F88 <sub>H</sub> -F8B <sub>H</sub>	Port Multiplier Device 1 Status Register
F8C <sub>H</sub> -F8F <sub>H</sub>	Port Multiplier Device 1 QActive Register
F90 <sub>H</sub> -FF7 <sub>H</sub>	Port Multiplier Device Registers for Devices 2-14
FF8 <sub>H</sub> -FFB <sub>H</sub>	Port Multiplier Device 15 Status Register
FFC <sub>H</sub> -FFF <sub>H</sub>	Port Multiplier Device 15 QActive Register

**Table 41. Port LRAM Slot layout**

Address Offset	Description	
000 <sub>H</sub> -01F <sub>H</sub>	Current FIS and Control	Port Request Block (PRB)
020 <sub>H</sub> -02F <sub>H</sub>	Scatter/Gather Entry 0 or ATAPI command packet	
030 <sub>H</sub> -03F <sub>H</sub>	Scatter/Gather Entry 1	
040 <sub>H</sub> -047 <sub>H</sub>	Command Activation Register (Actual)	
040 <sub>H</sub> -07F <sub>H</sub>	Scatter/Gather Table	
1C00 <sub>H</sub> -1C07 <sub>H</sub>	Command Activation Register (Shadow)	

A Port LRAM Slot is 128 bytes used to define Serial-ATA commands. The addresses shown above are for slot 0.

## Port Slot Status

Address Offset: 1800<sub>H</sub>  
Access Type: Read  
Reset Value: 0x0000\_0000

31	30	29	28	27	26	25	24	23	22	21	20	19	18	17	16	15	14	13	12	11	10	09	08	07	06	05	04	03	02	01	00
Slot Status																															

This register provides the status for the 31 Command Slots for the Serial-ATA port. This register also appears along with the Port Status register of the other port in Global register space. Reading this register will clear the Command Completion Status for the port if the Interrupt No Clear on Read bit (bit 3) of the Port Control register is 0. The register bits are defined below.

- **Bit [31]:** Attention (R) – This bit indicates that something occurred in the port that requires the attention of the host. Other port registers must be examined to determine the origin of the error. This bit is the logical OR of the masked interrupt conditions reported in the Port Interrupt Status register.
- **Bit [30:0]:** Slot Status (R) – These bits are the Active status bits corresponding to Slot numbers 30 to 0. The Active status bit is set when a command is transferred to the Slot RAM.

## Port Control Set

Address Offset: Set: 1000<sub>H</sub>  
Access Type: Write One To Set  
Reset Value: N/A

31	30	29	28	27	26	25	24	23	22	21	20	19	18	17	16	15	14	13	12	11	10	09	08	07	06	05	04	03	02	01	00	
Reserved						OOB Bypass	Reserved										LED On	Auto Interlock Accept	PM Enable	Interlock Accept	Interlock Reject	32-bit Activation	Scramble Disable	CONT Disable	Transmit BIST	Resume	Packet Length	LED Disable	Interrupt NCoR	Port Initialize	Device Reset	Port Reset

This register is used to direct various port operations. A one written to a bit position sets that bit in the control register.

- **Bit [31:26,24:16]:** Reserved (R). These bits are reserved.
- **Bit [25]:** OOB Bypass (W1S). If this bit is set, the Link will bypass the OOB initialization sequence following a reset. This bit is reset by Global Reset, and not reset by Port Reset.
- **Bit [15]:** LED On (W1S). This bit turns on the LED Port Activity indicator regardless of the state of LED Disable (bit 4).
- **Bit [14]:** Auto Interlock Accept (W1S). When this bit is set the link will accept any interlocked FIS reception. The link will transmit R\_OK in response to the received FIS.
- **Bit [13]:** PM Enable (W1S). This bit enables Port Multiplier support.
- **Bit [12]:** Interlock Accept (W1S). This bit is used to signal the link to accept an interlocked FIS reception. The link will transmit R\_OK in response to the received FIS. This bit is self-clearing.
- **Bit [11]:** Interlock Reject (W1S). This bit is used to signal the link to reject an interlocked FIS reception. The link will transmit R\_ERR in response to the received FIS. This bit is self-clearing.
- **Bit [10]:** 32-bit Activation (W1S). When this bit is set to one, a write to the low 32 bits of a Command Activation register will cause the 32-bit Activation Upper Address register contents to be written to the upper 32 bits of the Command Activation register and will trigger command execution. When this bit is zero, a write to the upper 32 bits or all 64 bits of a command activation register is required to trigger command execution. This bit is set for environments that do not address more than  $2^{32}$  bytes of host memory.
- **Bit [9]:** Scrambler Disable (W1S). When this bit is set to one, the Link scrambler operation is disabled.

- **Bit [8]:** CONT Disable (W1S). When this bit is set to one, the Link will not generate a CONT following repeated primitives.
- **Bit [7]:** Transmit BIST (W1S). This bit causes transmission of a BIST FIS.
- **Bit [6]:** Resume (W1S). This bit is used to enable processing of outstanding commands to additional devices connected to a port multiplier after a command error has occurred. When this bit is set, the internal BUSY status will be set for the device corresponding to the value of the current Port Multiplier Port. This will prevent additional commands from being sent to the device in error until a Port Initialize operation is performed.
- **Bit [5]:** Packet Length (W1S). This bit directs the length of the packet command to be sent for commands with packet protocol. When this bit is zero, a 12-byte packet will be sent. When this bit is one, a 16-byte packet will be sent. This bit should be set to the same value as derived from word 0 of the identify packet command returned data.
- **Bit [4]:** LED Disable (R/W). This bit disables the operation of the LED Port Activity indicator.
- **Bit [3]:** Interrupt No Clear on Read (W1S). When this bit is set to one, a command completion interrupt may be cleared only by writing a one to the Command Completion bit in the Port Interrupt Status register. When this bit is zero, reading the Port Slot Status register may also be used to clear the Command Completion interrupt.
- **Bit [2]:** Port Initialize (W1S). Setting this bit to one causes all commands to be flushed from the port and all command execution parameters to be set to an initialized state. Setting this bit to one causes the port ready bit in the port status register to be cleared to zero. When the initialization procedure is complete, the port ready bit will be set to one. This bit is self-clearing and will be cleared upon execution by the port.
- **Bit [1]:** Device Reset (W1S). Setting this bit to one causes all commands to be flushed from the port and all command execution parameters to be set to an initialized state. Setting this bit to one causes the port ready bit in the port status register to be cleared to zero. The port will generate the COMRESET primitive on the serial ATA bus. When the out of band sequence and initialization procedure is complete, the port ready bit will be set to one. This bit is self-clearing and will be cleared upon execution by the port.
- **Bit [0]:** Port Reset (W1S). Setting this bit to one causes the port to be held in a reset state. No commands will be executed while in this state. All port registers and functions are reset to their initial state, except as noted below. All commands are flushed from the port and all command execution parameters are set to an initialized state. Setting this bit to one causes the port ready bit in the port status register to be cleared to zero. Upon setting this bit to zero from an asserted state, the port will generate the COMRESET primitive on the serial ATA bus. When the out of band sequence and initialization procedure is complete, the port ready bit will be set to one. This bit is set to one by the Global reset, which is set by a PCI reset, and remains set until cleared by the host (by writing a one to bit 0 of the Port Control Clear register).  
The register bits that are not initialized by the Port Reset are:
  - OOB Bypass (bit 25) in Port Control (this register)
  - Port PHY Configuration register (all bits)



## Port Status

Address Offset: 1000<sub>H</sub>  
Access Type: Read  
Reset Value: 0x001F\_0001

31	30	29	28	27	26	25	24	23	22	21	20	19	18	17	16	15	14	13	12	11	10	09	08	07	06	05	04	03	02	01	00	
Port Ready	Reserved					OOB Bypass	Reserved					Active Slot					LED On	Auto Interlock Accept	PM Enable	Interlock Accept	Interlock Reject	32-bit Activation	Scramble Disable	CONT Disable	Transmit BIST	Resume	Packet Length	LED Disable	Interrupt NCoR	Port Initialize	Device Reset	Port Reset

This register is used to determine the status of various port functions.

- **Bit [31]:** Port Ready (R). This bit reports the Port Ready status. The transition from 0 to 1 of this bit generates the Port Ready Interrupt Status (bit 18/2 of the Port Interrupt Status register).
- **Bit [30:26,24:21]:** Reserved (R). These bits are reserved.
- **Bit [20:16]:** Active Slot (R). This bit field contains the slot number of the command currently being executed. When a command error occurs, this bit field indicates the slot containing the command in error.
- **Bit [25,15:0]:** These bits reflect the current state of the corresponding bits in the Port Control register. Refer to the Port Control Set register for a complete description.

## Port Control Clear

Address Offset: 1004<sub>H</sub>  
Access Type: Write One To Clear  
Reset Value: N/A

31	30	29	28	27	26	25	24	23	22	21	20	19	18	17	16	15	14	13	12	11	10	09	08	07	06	05	04	03	02	01	00
Reserved					OOB Bypass	Reserved					LED On	Auto Interlock Accept	PM Enable	Reserved	32-bit Activation	Scramble Disable	CONT Disable	Transmit BIST	Resume	Packet Length	LED Disable	Interrupt NCoR	Reserved	Port Reset							

This register is used to direct various port operations. A one written to a bit position clears that bit in the control register.

- **Bit [31:26,24:16,12:11,2:1]:** Reserved (R). These bits are reserved.
- **Bit [25, 15:13,10:3,0]:** (W1C) Writing a one to these bits clears the associated bit position of the Port Control register. Refer to the Port Control Set register for bit descriptions.

## Port Interrupt Status

Address Offset: 1008<sub>H</sub>

Access Type: Read/Write 1 Clear

Reset Value: 0x0000\_0000

31	30	29	28	27	26	25	24	23	22	21	20	19	18	17	16	15	14	13	12	11	10	09	08	07	06	05	04	03	02	01	00
Reserved				SDB Notify	Hshk Error Thresh	CRC Error Thresh	8b/10 Error Thresh	DevExchg	UnrecFIS	Comwake	PhyRdyChg	PM Change	Port Ready	Command Error	Cmd Completion	Reserved				SDB Notify	Hshk Error Thresh	CRC Error Thresh	8b/10 Error Thresh	DevExchg	UnrecFIS	Comwake	PhyRdyChg	PM Change	Port Ready	Command Error	Cmd Completion

This register is used to report the interrupt status. The status bits in the upper half of the register report the described condition. The status bits in the lower half of the register are masked by the corresponding interrupt enable bits or by the setting in the corresponding interrupt threshold registers. Writing a 1 to either interrupt status bit clears it.

- **Bit [31:28,15:12]:** Reserved (R). These bits are reserved.
- **Bit [27/11]:** SDB Notify (W1C). This bit indicates that a Set Device Bits FIS was received with the N-bit (bit 15 of first dword) set to one.
- **Bit [26/10]:** Handshake Error Threshold (W1C). This bit indicates that the Handshake error count is equal to or greater than the Handshake error threshold. Bit 10 is masked if the Handshake Error Threshold register contains a zero threshold setting. When a 1 is written to this bit, both the status bit and the Handshake Error Counter are cleared.
- **Bit [25/9]:** CRC Error Threshold (W1C). This bit indicates that the CRC error count is equal to or greater than the CRC error threshold. Bit 9 is masked if the CRC Error Threshold register contains a zero threshold setting. When a 1 is written to this bit, both the status bit and the CRC Error Counter are cleared.
- **Bit [24/8]:** 8b/10b Decode Error Threshold (W1C). This bit indicates that the 8b/10b Decode error count is equal to or greater than the 8b/10b Decode error threshold. Bit 8 is masked if the 8b/10b Decode Error Threshold register contains a zero threshold setting. When a 1 is written to this bit, both the status bit and the 8b/10b Decode Error Counter are cleared.
- **Bit [23/7]:** DevExchg (Device Exchanged) (W1C) – This bit is the X bit in the DIAG field of the SError register. It may be cleared by writing a corresponding one bit to either register.
- **Bit [22/6]:** UnrecFIS (Unrecognized FIS Type) (W1C) – This bit is the F bit in the DIAG field of the SError register. It may be cleared by writing a corresponding one bit to either register.
- **Bit [21/5]:** ComWake (W1C) – This bit is the W bit in the DIAG field of the SError register. It may be cleared by writing a corresponding one bit to either register.
- **Bit [20/4]:** PhyRdyChg (W1C) – This bit is the N bit in the DIAG field of the SError register. It may be cleared by writing a corresponding one bit to either register.
- **Bit [19/3]:** PM Change (W1C). This bit indicates that a change has occurred in the power management state.
- **Bit [18/2]:** Port Ready (W1C). This bit indicates that the port has become ready to accept and execute commands. This status indicates that Port Ready (bit 31 in the Port Status register) has made a 0 to 1 transition. Clearing this status does not change the Port Ready bit in the Port Status register and this status is not set subsequently until the Port Ready bit changes state.
- **Bit [17/1]:** Command Error (W1C). This bit indicates that an error occurred during command execution. The error type can be determined via the port error register.
- **Bit [16/0]:** Command Completion (W1C). This bit indicates that one or more commands have completed execution.

## Port Interrupt Enable Set / Port Interrupt Enable Clear

Address Offset: 1010<sub>H</sub> / 1014<sub>H</sub>

Access Type: Read/Write 1 Set/Write 1 Clear

Reset Value: 0x0000\_0000

31	30	29	28	27	26	25	24	23	22	21	20	19	18	17	16	15	14	13	12	11	10	09	08	07	06	05	04	03	02	01	00	
Interrupt Steering		Reserved																			SDB Notify	Reserved			DevExchg	UnrecFIS	Comwake	PhyRdyChg	PLM Change	Port Ready	Command Error	Cmd Completion

The Interrupt Enable register is controlled by these registers. Writing to the Interrupt Enable Set register sets the Interrupt Enable bits; the enable bit is set for each corresponding bit to which a 1 is written. Writing to the Interrupt Enable Clear register clears the Interrupt Enable bits; the enable bit is cleared for each corresponding bit to which a 1 is written. The Interrupt Enable register may be read at either address offset.

Note that bits 8, 9, and 10 do not have an enable bit; the corresponding interrupts are enabled by corresponding threshold registers.

- **Bit [31:30]:** Interrupt Steering (R/W). This bit field specifies which one of the four interrupts is to be used for interrupts from this port. INTA is selected by 00<sub>B</sub>; INTB by 01<sub>B</sub>; INTC by 10<sub>B</sub>; and INTD by 11<sub>B</sub>.
- **Bit [29:12,10:8]:** Reserved (R). These bits are reserved and return zeros on a read.
- **Bit [11,7:0]:** Interrupt Enables (R/W1S/W1C). These bits are the interrupt enables for the corresponding bits of the Interrupt Status register.

## 32-bit Activation Upper Address

Address Offset: 101C<sub>H</sub>

Access Type: Read/Write

Reset Value: 0x0000\_0000

31	30	29	28	27	26	25	24	23	22	21	20	19	18	17	16	15	14	13	12	11	10	09	08	07	06	05	04	03	02	01	00
Upper Address																															

This register contains the 32-bit value written to the upper half of the Command Activation register when the lower half of that register is written and the 32-bit Activation control bit (bit 10) is set in the Port Control register.

## Port Command Execution FIFO

Address Offset: 1020<sub>H</sub>

Access Type: Read/Write

Reset Value: 0x0000\_00XX

31	30	29	28	27	26	25	24	23	22	21	20	19	18	17	16	15	14	13	12	11	10	09	08	07	06	05	04	03	02	01	00
Reserved																										Execution Slot Number					

When written, this register causes the supplied slot number to be pushed into the tail of the command execution FIFO. A valid PRB must be populated in the associated slot in port LRAM. When read, this register supplies the entry at the head of the command execution FIFO. The FIFO is not popped as a result of a read operation.

## Port Command Error

Address Offset: 1024<sub>H</sub>  
Access Type: Read  
Reset Value: 0x0000\_0000

31	30	29	28	27	26	25	24	23	22	21	20	19	18	17	16	15	14	13	12	11	10	09	08	07	06	05	04	03	02	01	00
Error Code																															

This register contains the error type resulting from a command error. Table 42 lists the error codes, error names, and error descriptions.

**Table 42. Command Error Codes**

Error Name	Code	Description
DEVICEERROR	1	The ERR bit was set in a "register - device to host" FIS received from the device. The task file registers are written back to PRB slot for host scrutiny.
SDBERROR	2	The ERR bit was set in a "set device bits" FIS received from the device.
DATAFISERROR	3	The Sil3132 detected an error during command execution that was not reported by the device upon command completion.
SENDERFISERROR	4	The Sil3132 was unable to send the Initial command FIS for a command. This can occur if a low-level link error occurs during command transmission.
INCONSISTENTSTATE	5	The Sil3132 detected an inconsistency in protocol. Any departure from standard Serial ATA protocol that causes indecision in the internal sequencers will cause this error.
DIRECTIONERROR	6	A Data FIS was received when a write data protocol was specified or a DMA Activate FIS was received when a read data protocol was specified.
UNDERRUNERROR	7	While transferring data from the Sil3132 to a device, the end of the Scatter Gather list was encountered before the entire transfer was completed. The device is requesting additional data but there is no Scatter Gather Entry to define the source of data.
OVERRUNERROR	8	While transferring data from a device to the Sil3132, the end of the Scatter Gather list was encountered before the entire transfer was completed. Data was received from the device but there is no Scatter Gather Entry to define where the data should be deposited.
LLOVERRUNERROR	9	Low level overrun error. While transferring data from a device to the Sil3132, the transfer count received in a PIO Setup or DMA Setup FIS has been satisfied and there is additional data being received from the device.
PACKETPROTOCOLERROR	11	During the first PIO setup of Packet command, the data direction bit was invalid, indicating a transfer from device to host.
PLDSGTERRORBOUNDARY	16	A requested Scatter Gather Table not aligned on a quadword boundary. All addresses defining Scatter Gather Tables must be quadword aligned. Bits[2:0] must be zeroes.
PLDSGTERRORTARGETABORT	17	A PCI Target Abort occurred while the Sil3132 was fetching a Scatter Gather Table from host memory.
PLDSGTERRORMASTERABORT	18	A PCI Master Abort occurred while the Sil3132 was fetching a Scatter Gather Table from host memory.
PLDSGTERRORPCIPERR	19	A PCI Parity Error occurred while the Sil3132 was fetching a Scatter Gather Table from host memory.
PLDCMDERRORBOUNDARY	24	The address of a PRB written to a command activation register was not aligned on a quadword boundary. All PRB addresses must be quadword aligned. Bits[2:0] must be zeroes.
PLDCMDERRORTARGETABORT	25	A PCI Target Abort occurred while the Sil3132 was fetching a Port Request Block (PRB) from host memory.

**Table 42. Command Error Codes (continued)**

Error Name	Code	Description
PLDCMDERRORMASTERABORT	26	A PCI Master Abort occurred while the Sil3132 was fetching a Port Request Block (PRB) from host memory.
PLDCMDERRORPCIPERR	27	A PCI Parity Error occurred while the Sil3132 was fetching a Port Request Block (PRB) from host memory.
PSDERRORTARGETABORT	33	A PCI Target Abort occurred while data transfer was underway between the Sil3132 and host memory.
PSDERRORMASTERABORT	34	A PCI Master Abort occurred while data transfer was underway between the Sil3132 and host memory.
PSDERRORPCIPERR	35	A PCI Parity Error occurred while data transfer was underway between the Sil3132 and host memory.
SENDSERVICEERROR	36	A FIS was received while attempting to transmit a Service FIS. Following the receipt of a Set Device Bits FIS containing a service request, the device sent another FIS before allowing the host to send a Service FIS.

## Port FIS Configuration

Address Offset: 1028<sub>H</sub>

Access Type: Read/Write

Reset Value: 0x1000\_1555

31	30	29	28	27	26	25	24	23	22	21	20	19	18	17	16	15	14	13	12	11	10	09	08	07	06	05	04	03	02	01	00
Reserved		FIS27cfg		FIS34cfg		FIS39cfg		FIS41cfg		FIS46cfg		FIS58cfg		FIS5Fcfg		FISA1cfg		FISA6cfg		FISB8cfg		FISBFcfg		FISC7cfg		FISD4cfg		FISD9cfg		FISOcfg	

This register contains bits for controlling Serial ATA FIS reception. For each possible FIS type, a 2-bit code defines the desired reception behavior as follows:

- 00 – Accept FIS without interlock.
- 01 – Reject FIS without interlock
- 10 – Interlock FIS. Receive FIS into slot reserved for interlocked FIS reception. If no slot has been reserved, reject the FIS.
- 11 – Reserved.

Bit[1:0] (FISOcfg) defines the 2-bit code for all other FIS types not defined by bits [29:2].

The following table defines the default behavior of FIS configuration.

**Table 43. Default FIS Configurations**

FIS Code	FIS Name	Configuration Bits		Default Action
		Signals	Default Value	
27h	Register (Host to Device)	fis27cfg[1:0]	01b	reject FIS without interlock
34h	Register (Device to Host)	fis34cfg[1:0]	00b	accept FIS without interlock
39h	DMA Activate	fis39cfg[1:0]	00b	accept FIS without interlock
41h	DMA Setup	fis41cfg[1:0]	00b	accept FIS without interlock
46h	Data	fis46cfg[1:0]	00b	accept FIS without interlock
58h	BIST Activate	fis58cfg[1:0]	00b	accept far-end retimed loopback, reject any other
5Fh	PIO Setup	fis5Fcfg[1:0]	00b	accept FIS without interlock
A1h	Set Device Bits	fisa1cfg[1:0]	00b	accept FIS without interlock
A6h	reserved	fisa6cfg[1:0]	01b	reject FIS without interlock
B8h	reserved	fisb8cfg[1:0]	01b	reject FIS without interlock
BFh	reserved	fisbFcfg[1:0]	01b	reject FIS without interlock
C7h	reserved	fisc7cfg[1:0]	01b	reject FIS without interlock
D4h	reserved	fisd4cfg[1:0]	01b	reject FIS without interlock
D9h	reserved	fisd9cfg[1:0]	01b	reject FIS without interlock
Others	reserved	fisocfg[1:0]	01b	reject FIS without interlock

### Port PCI Express Request FIFO Threshold

Address Offset: 102C<sub>H</sub>  
Access Type: Read/Write  
Reset Value: 0x0000\_0000

31	30	29	28	27	26	25	24	23	22	21	20	19	18	17	16	15	14	13	12	11	10	09	08	07	06	05	04	03	02	01	00
Reserved					PCI Exp Write Request Threshold							Reserved			Reserved				PCI Exp Read Request Threshold					Reserved							

This register contains threshold levels at which the PCI Express master state machine will request the PCI Express bus relative to the amount of data or free space in the data FIFO. The data FIFO capacity is 2kbyte (256 Qwords). When writing to host memory (reading data from a device), the PCI Express Write Request Threshold is compared to the amount of data in the data FIFO. When the FIFO contents exceed the threshold value, a request is issued to write the data to host memory, emptying the contents of the data FIFO. When reading host memory (writing data to a device) the PCI Express Read Request Threshold is compared to the amount of free space in the data FIFO. When the free space exceeds the threshold value, a request is issued to read data from host memory to fill the FIFO.

- **Bit [31:27]:** Reserved (R). This bit field is reserved and returns zeros on a read.
- **Bit [26:19]:** PCI Exp Write Request Threshold (R/W). This field defines the number of Qwords that must be in the data FIFO before issuing a PCI Express request. A value of zero will cause a request if the FIFO contains any amount of data.
- **Bit [18:16]:** Reserved (R). This bit field is reserved and returns zeros on a read. This field is defined so that the host may write a byte count value into the threshold register.
- **Bit [15:11]:** Reserved (R). This bit field is reserved and returns zeros on a read.
- **Bit [10:3]:** PCI Exp Read Request Threshold (R/W). This field defines the number of Qwords that must be available in the data FIFO before issuing a PCI Express request. A value of zero will cause a request if the FIFO contains any free space and the DMA is active.
- **Bit [2:0]:** Reserved (R). This bit field is reserved and returns zeros on a read. This field is defined so that the host may write a byte count value into the threshold register.

### Port 8B/10B Decode Error Counter

Address Offset: 1040<sub>H</sub>

Access Type: Read/Write/Clear

Reset Value: 0x0000\_0000

31	30	29	28	27	26	25	24	23	22	21	20	19	18	17	16	15	14	13	12	11	10	09	08	07	06	05	04	03	02	01	00
8B/10B Decode Error Threshold																8B/10B Decode Error Counter															

This register counts the number of 8B/10B Decode Errors that have occurred since last cleared.

- **Bit [31:16]:** 8B/10B Decode Error Threshold (R/W). This bit field defines the count at which an interrupt will be asserted. When the count in bits 15:0 is equal to this value, an 8B/10B interrupt will be latched. A threshold value of zero disables interrupt assertion and masks the corresponding interrupt status bit in the Port Interrupt Status register.
- **Bit [15:0]:** 8B/10B Decode Error Count (R/WC). This bit field represents the count of 8B/10B errors that have occurred since this register was last written. Any write to this register field will clear both the counter and the interrupt condition. Clearing the interrupt status bit will also clear the counter. The count will not overflow. Once this register reaches its maximum count, it will retain that count until cleared to zero by a write operation.

### Port CRC Error Counter

Address Offset: 1044<sub>H</sub>

Access Type: Read/Write/Clear

Reset Value: 0x0000\_0000

31	30	29	28	27	26	25	24	23	22	21	20	19	18	17	16	15	14	13	12	11	10	09	08	07	06	05	04	03	02	01	00
CRC Error Counter Threshold																CRC Error Counter															

This register counts the number of Serial ATA CRC Errors that have occurred since last cleared.

- **Bit [31:16]:** Serial ATA CRC Error Threshold (R/W). This bit field defines the count at which an interrupt will be asserted. When the count in bits 15:0 is equal to this value, a serial ATA CRC interrupt will be latched. A threshold value of zero disables interrupt assertion and masks the corresponding interrupt status bit in the Port Interrupt Status register.
- **Bit [15:0]:** Serial ATA CRC Error Count (R/WC). This bit field represents the count of Serial ATA CRC errors that have occurred since this register was last written. Any write to this register will clear both the counter and the interrupt condition. Clearing the interrupt status bit will also clear the counter. The count will not overflow. Once this register reaches its maximum count, it will retain that count until cleared to zero by a write operation.

## Port Handshake Error Counter

Address Offset: 1048<sub>H</sub>

Access Type: Read/Write/Clear

Reset Value: 0x0000\_0000

31	30	29	28	27	26	25	24	23	22	21	20	19	18	17	16	15	14	13	12	11	10	09	08	07	06	05	04	03	02	01	00
Serial ATA Handshake Error Counter Threshold																Serial ATA Handshake Error Counter															

This register counts the number of Serial ATA Handshake Errors that have occurred since last cleared.

- **Bit [31:16]:** Serial ATA Handshake Error Threshold (R/W). This bit field defines the count at which an interrupt will be asserted. When the count in bits 15:0 is equal to this value, a serial ATA Handshake interrupt will be latched. A threshold value of zero disables interrupt assertion and masks the corresponding interrupt status bit in the Port Interrupt Status register.
- **Bit [15:0]:** Serial ATA Handshake Error Count (R/WC). This bit field represents the count of Serial ATA Handshake errors that have occurred since this register was last written. Any write to this register will clear both the counter and the interrupt condition. Clearing the interrupt status bit will also clear the counter. The count will not overflow. Once this register reaches its maximum count, it will retain that count until cleared to zero by a write operation.

## Port PHY Configuration

Address Offset: 1050<sub>H</sub>

Access Type: Read/Write

Reset Value: 0x0000\_020C

31	30	29	28	27	26	25	24	23	22	21	20	19	18	17	16	15	14	13	12	11	10	09	08	07	06	05	04	03	02	01	00
PHY Status																PHY Config															

The Port PHY Configuration register is reset by the Global Reset, not by the Port Reset. The reset value is 0x0000020C.

- **Bit[31:16]:** PHY Status (R). These bits report status of the PHY (currently always 0).
- **Bit[15:5]:** PHY Config (R/W). These bits configure the PHY. The value should not be changed as erratic operation may result.
- **Bit[4:0]:** Tx Amplitude (R/W) These bits set the nominal output swing for the Transmitter. The amplitude will be increased by 50mV by an increment of the value.



## Port Device Status Register

Address Offset: F80<sub>H</sub> (PM Port 0)/ F88<sub>H</sub> (PM Port 1)/ F90<sub>H</sub> (PM Port 2)/ F98<sub>H</sub> (PM Port 3)/ FA0<sub>H</sub> (PM Port 4)/ FA8<sub>H</sub> (PM Port 5)/ FB0<sub>H</sub> (PM Port 6)/ FB8<sub>H</sub> (PM Port 7)/ FC0<sub>H</sub> (PM Port 8)/ FC8<sub>H</sub> (PM Port 9)/ FD0<sub>H</sub> (PM Port 10)/ FD8<sub>H</sub> (PM Port 11)/ FE0<sub>H</sub> (PM Port 12)/ FE8<sub>H</sub> (PM Port 13)/ FF0<sub>H</sub> (PM Port 14)/ FF8<sub>H</sub> (PM Port 15)

Access Type: Read/Write

31	30	29	28	27	26	25	24	23	22	21	20	19	18	17	16	15	14	13	12	11	10	09	08	07	06	05	04	03	02	01	00
reserved														service_pending	legacy_queue	native_queue	device_busy	exec_active_slot						pio_end_status							

These 16 registers contain information useful for diagnosing behavior of the execution unit. These 16 registers contain Port Multiplier device specific information. Address Offset bits 6 to 3 are the Port Multiplier Port number for the device to which the status bits apply. There is one register for each of 16 possible port multiplier ports. These registers are part of the LRAM.

- **Bit [31:17]:** Reserved
- **Bit [16]:** service\_pending (R/W). Indicates that a service request has been received from this device and a SERVICE command has not yet been acknowledged.
- **Bit [15]:** legacy\_queue (R/W). Indicates that one or more legacy queued commands are outstanding to this device.
- **Bit [14]:** native\_queue (R/W). Indicates that one or more native queued commands are outstanding to this device.
- **Bit [13]:** device\_busy (R/W). Virtual BSY bit indicating that a command has been issued to the device without receipt of a final register FIS or that a data transfer is in progress.
- **Bit [12:08]:** exec\_active\_slot (R/W). Contains the slot number of the last command active on this device.
- **Bit [07:00]:** pio\_end\_status (R/W). Contains the PIO ending status of the last PIO setup command received from this device.

## Port Device QActive Register

Address Offset: F84<sub>H</sub> (PM Port 0)/ F8C<sub>H</sub> (PM Port 1)/ F94<sub>H</sub> (PM Port 2)/ F9C<sub>H</sub> (PM Port 3)/ FA4<sub>H</sub> (PM Port 4)/ FAC<sub>H</sub> (PM Port 5)/ FB4<sub>H</sub> (PM Port 6)/ FBC<sub>H</sub> (PM Port 7)/ FC4<sub>H</sub> (PM Port 8)/ FCC<sub>H</sub> (PM Port 9)/ FD4<sub>H</sub> (PM Port 10)/ FDC<sub>H</sub> (PM Port 11)/ FE4<sub>H</sub> (PM Port 12)/ FEC<sub>H</sub> (PM Port 13)/ FF4<sub>H</sub> (PM Port 14)/ FFC<sub>H</sub> (PM Port 15)

Access Type: Read/Write

31	30	29	28	27	26	25	24	23	22	21	20	19	18	17	16	15	14	13	12	11	10	09	08	07	06	05	04	03	02	01	00
QActive[31:0]																															

These 16 registers contain Port Multiplier device specific status indicating outstanding queued commands in the device. For each bit set to one, a queued command, legacy or native, is outstanding associated with the slot number corresponding to the bit position. There is one register for each of 16 possible port multiplier ports. Address Offset bits 6 to 3 are the Port Multiplier Port number for the device to which the status bits apply.

- **Bit [31:00]:** Each bit corresponds to a slot number that contains an active outstanding legacy or native queued command.

## Port Context Register

Address Offset: 1E04<sub>H</sub>

Access Type: Read

31	30	29	28	27	26	25	24	23	22	21	20	19	18	17	16	15	14	13	12	11	10	09	08	07	06	05	04	03	02	01	00
Reserved																							PM Port			Slot					

- **Bit [31:09]:** Reserved
- **Bit [08:05]:** PM Port (R). This field contains the Port Multiplier port number corresponding to the last FIS transferred (transmit or receive). Upon a processing halt due to a device specific error, this field contains the PM port corresponding to the device that returned error status.
- **Bit [04:00]:** Slot (R). This field contains the slot number of the last command processed by the execution unit. Note that this slot number does not necessarily correspond to the command in error during error halt conditions. For native queue error recovery, the command slot in error must be determined by issuing a READ LOG EXTENDED to the device to determine the tag number of the command in error.

## SControl

Address Offset: 1F00<sub>H</sub>

Access Type: Read/Write

Reset Value: 0x0000\_0000

31	30	29	28	27	26	25	24	23	22	21	20	19	18	17	16	15	14	13	12	11	10	09	08	07	06	05	04	03	02	01	00
Reserved												PMP			SPM			IPM			SPD			DET							

This register is the SControl register as defined by the Serial ATA specification.

- **Bit [31:16]:** Reserved (R). This bit field is reserved and returns zeros on a read.
- **Bit [19:16]:** PMP (R/W). This field identifies the currently selected Port Multiplier port for accessing the SActive register and some bit fields of the Diagnostic registers.
- **Bit [15:12]:** SPM (R/W). This field selects a power management state. A non-zero value written to this field causes initiation of the select power management state. This field self-resets to 0 as soon as action begins to initiate the power management state transition.

Value	Definition
0000	No power management state transition requested
0001	Transition to the Partial power management state initiated
0010	Transition to the Slumber power management state initiated
0100	Transition from a power management state initiated (ComWake asserted)
others	Reserved

- **Bit [11:08]:** IPM (R/W) – This field identifies the interface power management states that may be invoked via the Serial ATA interface power management capabilities.

Value	Definition
0000	No interface power management restrictions (Partial and Slumber modes enabled)
0001	Transitions to the Partial power management state are disabled
0010	Transitions to the Slumber power management state are disabled
0011	Transitions to both the Partial and Slumber power management states are disabled
others	Reserved

- **Bit [07:04]: SPD (R/W)** – This field identifies the highest allowed communication speed the interface is allowed to negotiate.

Value	Definition
0000	No restrictions (default value)
0001	Limit to Generation 1 (1.5 Gbit/s)
0010	Limit to Generation 2 (3.0 Gbit/s)
others	Reserved

- **Bit [03:00]: DET (R/W)** – This field controls host adapter device detection and interface initialization.

Value	Action
0000	No action
0001	COMRESET is periodically generated until another value is written to the field
0100	No action
Others	Reserved, no action

## SStatus

Address Offset: 1F04<sub>H</sub>

Access Type: Read

Reset Value: 0x0000\_0000

31	30	29	28	27	26	25	24	23	22	21	20	19	18	17	16	15	14	13	12	11	10	09	08	07	06	05	04	03	02	01	00																		
Reserved																				IPM		SPD		DET																									

This register is the SStatus register as defined by the Serial ATA specification.

- **Bit [31:12]: Reserved (R)**. This bit field is reserved and returns zeros on a read.
- **Bit [11:08]: IPM (R)** – This field identifies the current interface power management state.

Value	Definition
0000	Device not present or communication not established
0001	Interface in active state
0010	Interface in Partial power management state
0110	Interface in Slumber power management state
Others	Reserved

- **Bit [07:04]: SPD (R)** – This field identifies the negotiated interface communication speed.

Value	Definition
0000	No negotiated speed
0001	Generation 1 communication rate (1.5 Gbit/s)
0010	Generation 2 communication rate (3.0 Gbit/s)
Others	Reserved

- **Bit [03:00]: DET (R)** – This field indicates the interface device detection and PHY state.

Value	Action
0000	No device detected and PHY communication not established
0001	Device presence detected but PHY communication not established
0011	Device presence detected and PHY communication established
0100	PHY in offline mode as a result of the interface being disabled or running in a BIST loopback mode
Others	Reserved, no action

## SError

Address Offset: 1F08<sub>H</sub>  
Access Type: Read/Write 1 Clear  
Reset Value: 0x0000\_0000

31	30	29	28	27	26	25	24	23	22	21	20	19	18	17	16	15	14	13	12	11	10	09	08	07	06	05	04	03	02	01	00	
R	R	R	R	R	X	F	T	S	H	C	D	B	W	I	N	R	R	R	R	E	P	C	T	R	R	R	R	R	R	R	M	I
DIAG																ERR																

This register is the SError register as defined by the Serial ATA specification.

- **Bit [31:16]:** DIAG (R/W1C) – This field contains bits defined as shown in the following table. Writing a 1 to the register bit clears the B, C, F, N, H, W, and X bits. Writing a 1 to the corresponding bits in the Port Interrupt Status register also clears the F, N, W, and X bits. The B, C, and H bits operate independently of the corresponding error counter registers; if the error counters are used, these bits should be ignored.

**Table 44. SError Register Bits (DIAG Field)**

Bit	Definition	Description
B	10b to 8b decode error	Latched decode error or disparity error from the Serial ATA PHY
C	CRC error	Latched CRC error from the Serial ATA PHY
D	Disparity error	N/A, always 0; this error condition is combined with the decode error and reported as B error
F	Unrecognized FIS type	Latched Unrecognized FIS error from the Serial ATA Link
I	PHY Internal error	N/A, always 0
N	PHYRDY change	Indicates a change in the status of the Serial ATA PHY
H	Handshake error	Latched Handshake error from the Serial ATA PHY
R	Reserved	Always 0
S	Link Sequence error	N/A, always 0
T	Transport state transition error	N/A, always 0
W	ComWake	Latched ComWake status from the Serial ATA PHY
X	Device Exchanged	Latched Comlnit status from the Serial ATA PHY

- **Bit [15:00]:** ERR – This field is not implemented; all bits are always 0.

## SActive

Address Offset: 1F0C<sub>H</sub>  
Access Type: Read/Write  
Reset Value: 0x0000\_0000

31	30	29	28	27	26	25	24	23	22	21	20	19	18	17	16	15	14	13	12	11	10	09	08	07	06	05	04	03	02	01	00
Active bits																															

This register provides indirect access of the Port Device QActive registers (see section 0 for description). It contains the Active bits used to determine the activity of native queued commands for the selected Port Multiplier port (selection in SControl). A one in any bit position indicates that the corresponding command is still active in the device.

## SNotification

Address Offset: 1F10<sub>H</sub>

Access Type: Read/Write 1 to Clear

Reset Value: 0x0000\_0000

31	30	29	28	27	26	25	24	23	22	21	20	19	18	17	16	15	14	13	12	11	10	09	08	07	06	05	04	03	02	01	00
Reserved																Notify bits															

This register reports the devices that have sent a Set Device Bits FIS with the Notification bit set.

- **Bit [31:16]:** Reserved (R). This bit field is reserved and returns zeros on a read.
- **Bit [15:00]:** Notify bits (R/W1C) – These 16 bits correspond to the 16 possible devices connected to a Port Multiplier on this port.

## Internal Register Space – Base Address 2

These registers are 32-bits wide and provide Indirect Register Access to the registers of the SiI3132. Access to this register space is through the PCI I/O space.

**Table 45. SiI3132 Internal Register Space – Base Address 2**

Address Offset	Register Name
00 <sub>H</sub>	Global Register Offset
04 <sub>H</sub>	Global Register Data
08 <sub>H</sub>	Port Register Offset
0C <sub>H</sub>	Port Register Data

### Global Register Offset

Address Offset: 00<sub>H</sub>

Access Type: Read/Write

Reset Value: 0x0000\_0000

31	30	29	28	27	26	25	24	23	22	21	20	19	18	17	16	15	14	13	12	11	10	09	08	07	06	05	04	03	02	01	00
Reserved																								Dword Offset	00						

This register provides indirect addressing of a Global Register otherwise accessible directly via Base Address Register 0. The dword address offset for an indirect access is in bits 6 to 2; bits 31 to 7, 1, and 0 are reserved and should always be 0.

### Global Register Data

Address Offset: 04<sub>H</sub>

Access Type: Read/Write

31	30	29	28	27	26	25	24	23	22	21	20	19	18	17	16	15	14	13	12	11	10	09	08	07	06	05	04	03	02	01	00
As defined for indirectly accessed register																															

This register provides the indirect access addressed by the Global Register Offset register.

### Port Register Offset

Address Offset: 08<sub>H</sub>  
Access Type: Read/Write  
Reset Value: 0x0000\_0000

31	30	29	28	27	26	25	24	23	22	21	20	19	18	17	16	15	14	13	12	11	10	09	08	07	06	05	04	03	02	01	00
Reserved																		Dword Offset									00				

This register provides indirect addressing of a Port Register otherwise accessible directly via Base Address Register 1. The dword address offset for an indirect access is in bits 13 to 2; bits 31 to 14, 1, and 0 are reserved and should always be 0.

### Port Register Data

Address Offset: 0C<sub>H</sub>  
Access Type: Read/Write

31	30	29	28	27	26	25	24	23	22	21	20	19	18	17	16	15	14	13	12	11	10	09	08	07	06	05	04	03	02	01	00
As defined for indirectly accessed register																															

This register provides the indirect access addressed by the Port Register Offset register.

## Power Management

The register bits described in Table 46 control Power Management in a SiI3132 port.

**Table 46. Power Management Register Bits**

Register	Bits	Description
Interrupt Status	PM Change Bit 3	This bit reports a change in the Power Management mode. It corresponds to the interrupt enabled by bit 3 of the Port Interrupt Enable register.
SError	W Bit 18	This bit reports a ComWake received from the Serial ATA bus. It corresponds to the interrupt enabled by bit 5 of the Port Interrupt Enable register.
Interrupt Status	ComWake Bit 5	
SControl	SPM Bits 15-12	This bit field initiates transitions to/from Partial or Slumber power management states; bit 14 corresponds to ComWake (exit power management); bit 13 corresponds to Slumber mode; bit 12 corresponds to Partial mode.
SControl	IPM Bits 11-8	This bit field disables transitions to Partial or Slumber power management states; bit 9 corresponds to Slumber mode; bit 8 corresponds to Partial mode.
SStatus	IPM Bits 11-8	This bit field reports the power management state; '0110' corresponds to Slumber mode; '0010' corresponds to Partial mode.

There are two power management modes: Partial and Slumber. These power management modes may be software initiated through the SControl register or device initiated from the Serial ATA device.

Transitions to and from either power management mode generate an interrupt, the Power Management Mode Change Interrupt, which may be masked in the Port Interrupt Enable register (bit 3).

Partial/Slumber mode may be initiated by software through the SControl register. By setting the SPM field to either '0001' (Partial) or '0010' (Slumber), software causes a PMREQ to the Serial ATA device, which will respond with either a PMACK or PMNAK. If a PMACK is received the Partial/Slumber mode is entered. A PMNAK is ignored; the request remains asserted.

The Serial ATA device may initiate Partial/Slumber mode. Software enables the acknowledgement of this request by setting the IPM field in the SControl register to '0001' (Partial), '0010' (Slumber), or '0011' (Partial or Slumber). If enabled, a PMACK will be sent to the device; if not enabled, a PMNAK will be sent. When the request is received and its acknowledgement is enabled, Partial/Slumber mode is entered.

Partial/Slumber mode status is reported in the SStatus register ('0010'/'0110' in the IPM field).

Partial/Slumber mode is cleared by ComWake (asserted when the SPM field is set to '0100').

## Flash, GPIO, EEPROM, and I<sup>2</sup>C Programming

### Flash Memory Access

The Sil3132 supports an external flash memory device of up to 4 Mbits (512 kbytes) in capacity. Access to the flash memory is available using either PCI Direct Access or Register Access.

#### PCI Direct Access

Access to the Expansion ROM is enabled by setting bit 0 in the Expansion Rom Base Address register at Offset 30h of the PCI Configuration Space. When this bit is set, bits [31:19] of the same register are programmable by the system to set the base address for all flash memory accesses. Read and write operations with the flash memory are initiated by Memory Read and Memory Write commands on the PCI bus. Accesses may be as bytes, words, or dwords.

#### Register Access

This type of flash memory access is carried out through a sequence of internal register read and write operations. The proper programming sequences are detailed below.

#### Flash Write Operation

Verify that Flash Address register bit 25 (Mem Access Start) is zero. The bit is one when a memory access is in progress. It is zero when the memory access is complete and ready for another operation.

Program the write address for the flash memory access. The address field is bits [18:0] in the Flash Address register.

Program the write data for the flash memory access. The data field is bits [7:0] in the Flash Memory Data register.

Program Flash Address register bit 24 (Mem Access Type) to zero for a memory write.

Initiate the flash memory access by setting bit 25 in the Flash Address register.

#### Flash Read Operation

Verify that Flash Address register bit 25 (Mem Access Start) is zero. The bit is one when a memory access is in progress. It is zero when the memory access is complete and ready for another operation.

Program the read address for the flash memory access. The address field is bits [18:0] in the Flash Address register.

Program Flash Address register bit 24 (Mem Access Type) to one for a memory read.

Initiate the flash memory access by setting bit 25 in the Flash Address register.

Verify that Flash Address register bit 25 (Mem Access Start) is clear. The bit is one when a memory access is in progress. It is zero when the memory access is complete.

Read the data from bits [7:0] in the Flash Memory Data register.

### I<sup>2</sup>C Operation

The Sil3132 provides a Multimaster I<sup>2</sup>C interface. For Auto-initialization of some PCI Configuration registers an external 256-byte EEPROM memory device may be connected to this I<sup>2</sup>C interface (see section 0). Two registers are provided for programmed read/write access to the I<sup>2</sup>C interface: the I<sup>2</sup>C Address register and the I<sup>2</sup>C Data/Control register.



## I<sup>2</sup>C Write Operation

Verify that I<sup>2</sup>C Data/Control register bit 31 (I<sup>2</sup>C Access Start) is zero. The bit is one when an access is in progress. It is zero when the access is complete and another operation may be started.

Write '1' to clear bit 28 in the I<sup>2</sup>C Data/Control register. This bit is set if an error occurred during a previous access.

Program the write address for the access in the I<sup>2</sup>C Address register.

Program the write data for the access in the I<sup>2</sup>C Data/Control register (bits 7:0).

Write zero to bit 24 (I<sup>2</sup>C Access Type) in the I<sup>2</sup>C Address register.

Initiate the I<sup>2</sup>C write by setting bit 31 (I<sup>2</sup>C Access Start) in the I<sup>2</sup>C Data/Control register.

Poll bit 31 in the I<sup>2</sup>C Data/Control register. The bit is one while an access is in progress. It becomes zero when the access completes. (Alternatively, the I<sup>2</sup>C Interrupt may be enabled. See the Global Control register and Global Interrupt Status register descriptions on page 55.)

Check bit 28 in the I<sup>2</sup>C Data/Control register. The bit is set if an error occurred during the access.

## I<sup>2</sup>C Read Operation

Verify that I<sup>2</sup>C Data/Control register bit 31 (I<sup>2</sup>C Access Start) is zero. The bit is one when an access is in progress. It is zero when the access is complete and another operation may be started.

Write '1' to clear bit 28 in the I<sup>2</sup>C Data/Control register. The bit is set if an error occurred during a previous access.

Program the read address for the access in the I<sup>2</sup>C Address register.

Write one to bit 24 (I<sup>2</sup>C Access Type) in the I<sup>2</sup>C Address register.

Initiate the I<sup>2</sup>C read by setting bit 31 (I<sup>2</sup>C Access Start) in the I<sup>2</sup>C Data/Control register.

Poll bit 31 in the I<sup>2</sup>C Data/Control register. The bit is one while an access is in progress. It becomes zero when the access completes. (Alternatively, the I<sup>2</sup>C Interrupt may be enabled. See the Global Control register and Global Interrupt Status register descriptions on page 55.)

Check bit 28 in the I<sup>2</sup>C Data/Control register. The bit is set if an error occurred during the access.

Read the data from bits 7:0 in the I<sup>2</sup>C Data/Control register.

## Disclaimers

These materials are provided on an "AS IS" basis. Silicon Image, Inc. and its affiliates disclaim all representations and warranties (express, implied, statutory or otherwise), including but not limited to: (i) all implied warranties of merchantability, fitness for a particular purpose, and/or non-infringement of third party rights; (ii) all warranties arising out of course-of-dealing, usage, and/or trade; and (iii) all warranties that the information or results provided in, or that may be obtained from use of, the materials are accurate, reliable, complete, up-to-date, or produce specific outcomes. Silicon Image, Inc. and its affiliates assume no liability or responsibility for any errors or omissions in these materials, makes no commitment or warranty to correct any such errors or omissions or update or keep current the information contained in these materials, and expressly disclaims all direct, indirect, special, incidental, consequential, reliance and punitive damages, including WITHOUT LIMITATION any loss of profits arising out of your access to, use or interpretation of, or actions taken or not taken based on the content of these materials.

Silicon Image, Inc. and its affiliates reserve the right, without notice, to periodically modify the information in these materials, and to add to, delete, and/or change any of this information.

Notwithstanding the foregoing, these materials shall not, in the absence of authorization under U.S. and local law and regulations, as required, be used by or exported or re-exported to (i) any U.S. sanctioned or embargoed country, or to nationals or residents of such countries; or (ii) any person, entity, organization or other party identified on the U.S. Department of Commerce's Denied Persons or Entity List, the U.S. Department of Treasury's Specially Designated Nationals or Blocked Persons List, or the Department of State's Debarred Parties List, as published and revised from time to time; (iii) any party engaged in nuclear, chemical/biological weapons or missile proliferation activities; or (iv) any party for use in the design, development, or production of rocket systems or unmanned air vehicles.

## Products and Services

The products and services described in these materials, and any other information, services, designs, know-how and/or products provided by Silicon Image, Inc. and/or its affiliates are provided on as "AS IS" basis, except to the extent that Silicon Image, Inc. and/or its affiliates provides an applicable written limited warranty in its standard form license agreements, standard Terms and Conditions of Sale and Service or its other applicable standard form agreements, in which case such limited warranty shall apply and shall govern in lieu of all other warranties (express, statutory, or implied). EXCEPT FOR SUCH LIMITED WARRANTY, SILICON IMAGE, INC. AND ITS AFFILIATES DISCLAIM ALL REPRESENTATIONS AND WARRANTIES (EXPRESS, IMPLIED, STATUTORY OR OTHERWISE), REGARDING THE INFORMATION, SERVICES, DESIGNS, KNOW-HOW AND PRODUCTS PROVIDED BY SILICON IMAGE, INC. AND/OR ITS AFFILIATES, INCLUDING BUT NOT LIMITED TO, ALL IMPLIED WARRANTIES OF MERCHANTABILITY, FITNESS FOR A PARTICULAR PURPOSE, AND/OR NON-INFRINGEMENT OF THIRD PARTY RIGHTS. YOU ACKNOWLEDGE AND AGREE THAT SUCH INFORMATION, SERVICES, DESIGNS, KNOW-HOW AND PRODUCTS HAVE NOT BEEN DESIGNED, TESTED, OR MANUFACTURED FOR USE OR RESALE IN SYSTEMS WHERE THE FAILURE, MALFUNCTION, OR ANY INACCURACY OF THESE ITEMS CARRIES A RISK OF DEATH OR SERIOUS BODILY INJURY, INCLUDING, BUT NOT LIMITED TO, USE IN NUCLEAR FACILITIES, AIRCRAFT NAVIGATION OR COMMUNICATION, EMERGENCY SYSTEMS, OR OTHER SYSTEMS WITH A SIMILAR DEGREE OF POTENTIAL HAZARD. NO PERSON IS AUTHORIZED TO MAKE ANY OTHER WARRANTY OR REPRESENTATION CONCERNING THE PERFORMANCE OF THE INFORMATION, PRODUCTS, KNOW-HOW, DESIGNS OR SERVICES OTHER THAN AS PROVIDED IN THESE TERMS AND CONDITIONS.

1060 E. Arques Avenue  
Sunnyvale, CA 94085  
T 408.616.4000 F 408.830.9530  
www.siliconimage.com

