

## Two-Phase DC/DC Controller for CPU Core Power Supply

### General Description

The RT9241A/B is a two-phase buck DC/DC controller integrated with all control functions for high performance processor VRM. The RT9241A/B drives 2 buck switching stages operating in 180 degree phase shift. The two-phase architecture provides high output current while maintaining low power dissipation on power devices and low stress on input and output capacitors. The high equivalent operating frequency also reduces the component dimension and the output voltage ripple in load transient.

RT9241A/B regulates both easily set voltage and current loops. Precise current sharing for power stage is achieved by differential input current sense and processing circuit. The settings of current sense, droop tuning and over current protection are independent to compensation circuit of voltage loop. The feature greatly facilitates the flexibility of CPU power supply design and tuning.

The RT9241A/B uses a 5-bit DAC of 1.1V to 1.85V (25mV/step) output with load current droop compensation to meet the strict VRM transient requirement. The IC monitors the  $V_{CORE}$  voltage for PGOOD and over voltage protection. Soft start, over current protection and programmable under voltage lockout are also provided to assure the safety of microprocessor and power system.

### Ordering Information

RT9241A/B	□	□
	Package Type	S : SOP-20
	Operating Temperature Range	P : Pb Free with Commercial Standard G : Green (Halogen Free with Commercial Standard)
	Operating Frequency Version	A : 200kHz B : 100kHz

Note :

RichTek Pb-free and Green products are :

- ▶RoHS compliant and compatible with the current requirements of IPC/JEDEC J-STD-020.
- ▶Suitable for use in SnPb or Pb-free soldering processes.
- ▶100%matte tin (Sn) plating.

### Features

- Two-Phase Power Conversion
- VRM 9.0 DAC Output with Active Droop Compensation for Fast Load Transient
- Precise Channel Current Sharing with Differential Sense Input
- Hiccup Mode Over Current Protection
- Programmable Under Voltage Lockout and Soft Start
- High Ripple Frequency, (Channel Frequency Times Channel Number)
- 100kHz Version (RT9241B) for Lower Switching Loss
- RoHS Compliant and 100% Lead (Pb)-Free

### Applications

- Power Supply for Server and Workstation
- Power Supply for High Current Microprocessor

### Pin Configurations

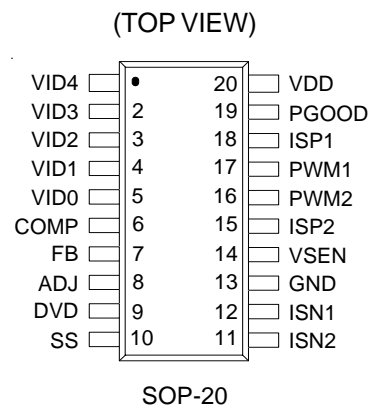

Typical Application Circuit

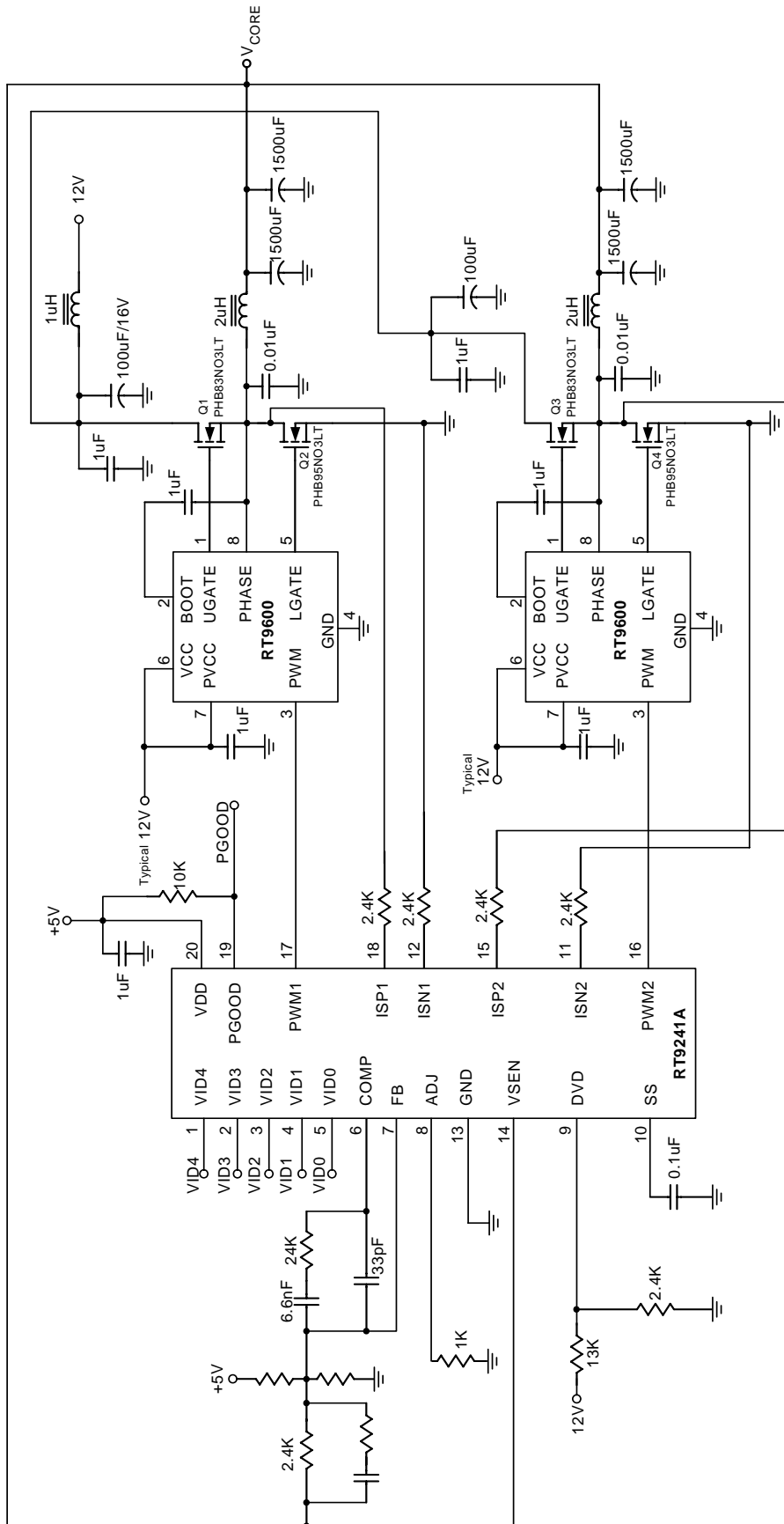

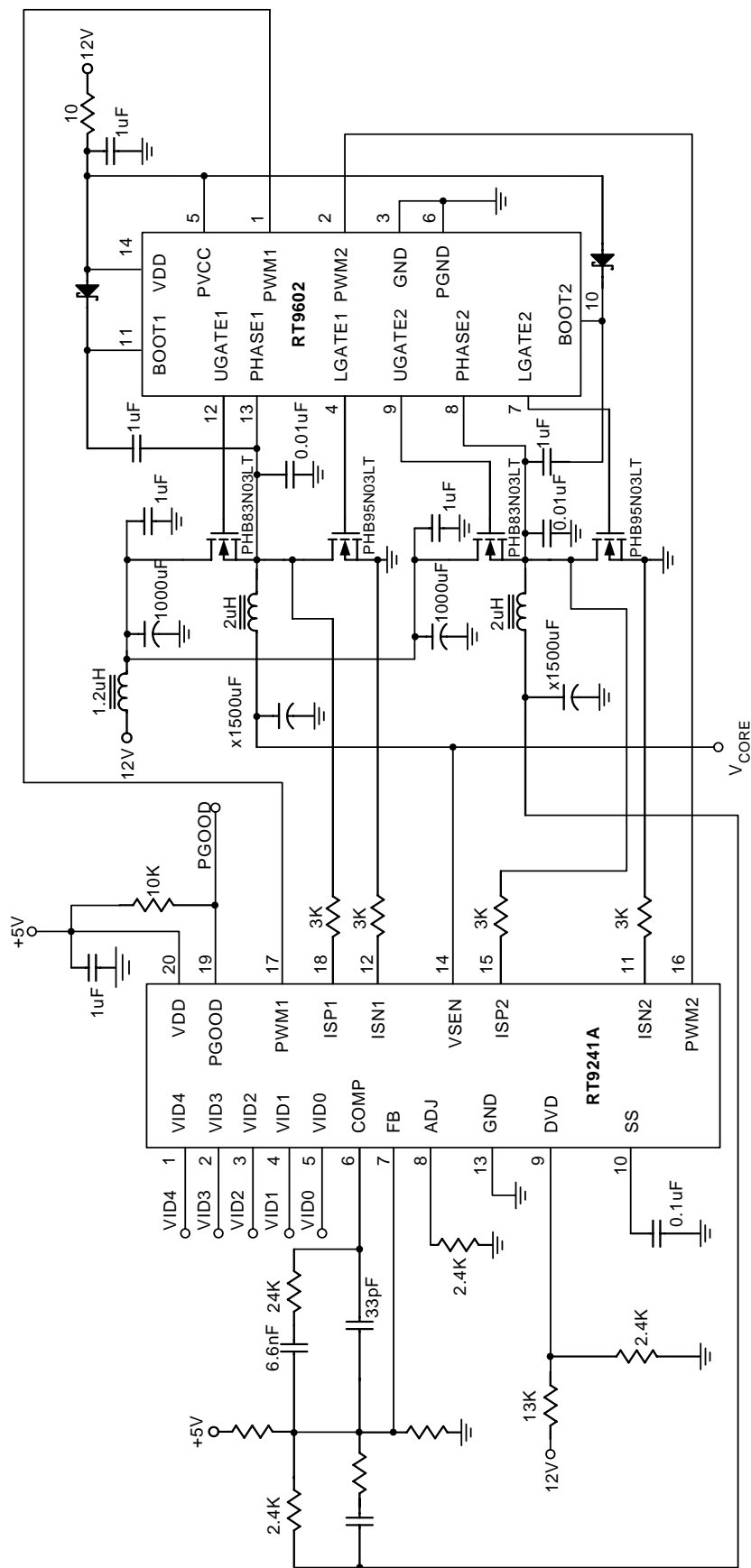

Function Block Diagram

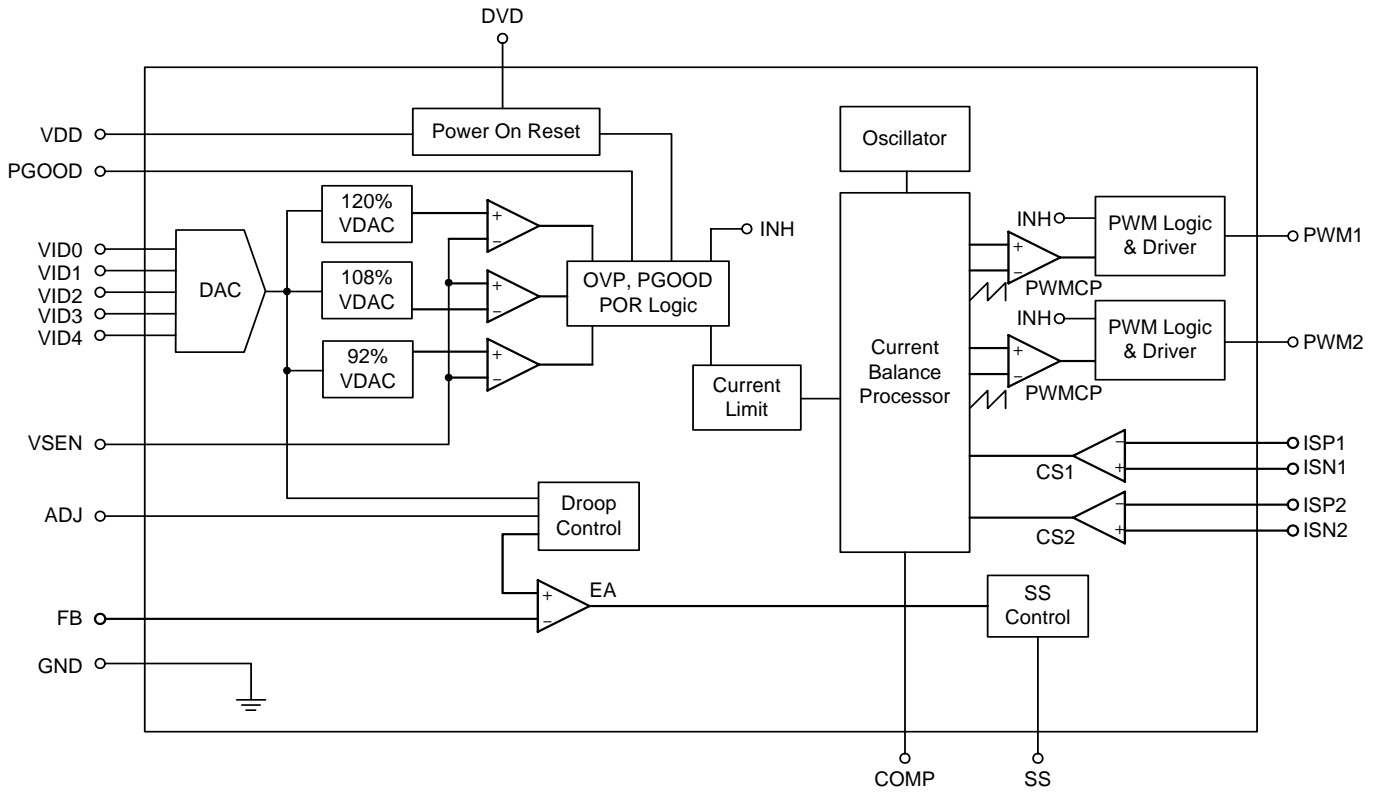

## Functional Pin Description

### **VID4, VID3, VID2, VID1 and VID0 ( Pin1,2,3,4,5)**

DAC voltage identification inputs for VRM9.0. These pins are TTL-compatible and internally pulled to VDD if left open.

### **COMP (Pin 6)**

Output of the error amplifier and input of the PWM comparator.

### **FB (Pin 7)**

Inverting input of the internal error amplifier.

### **ADJ (Pin 8)**

Current sense output for active droop adjust. Connect a resistor from this pin to GND to set the amount of load droop. This pin should not be opened.

### **DVD (Pin 9)**

Programmable power UVLO detection input. Trip threshold = 1.25V at  $V_{DVD}$  rising

### **SS (Pin 10)**

Connect this SS pin to GND with a capacitor to set the start time interval. Pull this pin below 1V (ramp valley of saw-tooth wave in pulse width modulator) to shutdown the converter output.

### **ISN1 (Pin 12), ISN2 (Pin 11)**

Current sense inputs from the individual converter channel's sense component GND nodes.

### **GND (Pin 13)**

Ground for the IC.

### **VSEN (Pin 14)**

Power good and over voltage monitor input. Connect to the microprocessor-CORE voltage.

### **ISP1 (Pin 18), ISP2 (Pin 15)**

Current sense inputs for individual converter channels. Tie this pin to the component sense node.

### **PWM1 (Pin 17), PWM2 (Pin 16)**

PWM outputs for each driven channel. Connect these pins to the PWM input of the MOSFET driver.

### **PGOOD (Pin 19)**

Power good open-drain output.

### **VDD (Pin 20)**

IC power supply. Connect this pin to a 5V supply.

Table 1 Output Voltage Program

Pin Name					Nominal Output Voltage DACOUT
VID4	VID3	VID2	VID1	VID0	
1	1	1	1	1	Off
1	1	1	1	0	1.100V
1	1	1	0	1	1.125V
1	1	1	0	0	1.150V
1	1	0	1	1	1.175V
1	1	0	1	0	1.200V
1	1	0	0	1	1.225V
1	1	0	0	0	1.250V
1	0	1	1	1	1.275V
1	0	1	1	0	1.300V
1	0	1	0	1	1.325V
1	0	1	0	0	1.350V
1	0	0	1	1	1.375V
1	0	0	1	0	1.400V
1	0	0	0	1	1.425V
1	0	0	0	0	1.450V
0	1	1	1	1	1.475V
0	1	1	1	0	1.500V
0	1	1	0	1	1.525V
0	1	1	0	0	1.550V
0	1	0	1	1	1.575V
0	1	0	1	0	1.600V
0	1	0	0	1	1.625V
0	1	0	0	0	1.650V
0	0	1	1	1	1.675V
0	0	1	1	0	1.700V
0	0	1	0	1	1.725V
0	0	1	0	0	1.750V
0	0	0	1	1	1.775V
0	0	0	1	0	1.800V
0	0	0	0	1	1.825V
0	0	0	0	0	1.850V

Note: (1) 0:Connected to GND (2) 1:Open

**Absolute Maximum Ratings**

- Supply Voltage ----- 7V
- Input, Output or I/O Voltage ----- GND-0.3V to V<sub>DD</sub>+0.3V
- Power Dissipation, P<sub>D</sub> @ T<sub>A</sub> = 25°C  
   SOP-20 ----- 0.625W
- Package Thermal Resistance  
   SOP-20, θ<sub>JA</sub> ----- 110°C /W
- Ambient Temperature Range ----- 0°C to 70°C
- Junction Temperature Range ----- 0°C to 125°C
- Storage Temperature Range ----- -40°C to 150°C
- Lead Temperature (Soldering, 10 sec.) ----- 260°C

**Electrical Characteristics**

(V<sub>DD</sub> = 5V, GND = 0V, T<sub>A</sub> = 25°C, unless otherwise specified)

Parameter	Symbol	Test Conditions	Min	Typ	Max	Units
<b>V<sub>DD</sub> Supply Current</b>						
Nominal Supply Current	I <sub>DD</sub>	PWM 1,2 Open	--	4	10	mA
<b>Power-On Reset</b>						
V <sub>DD</sub> Rising Threshold			4.2	4.35	4.6	V
V <sub>DD</sub> Falling Threshold			--	3.85	--	V
Hysteresis			0.2	0.6	--	V
V <sub>DVD</sub> Rising Trip Threshold			1.19	1.25	1.31	V
<b>Oscillator</b>						
Frequency	RT9241A	For each phase	170	200	230	kHz
	RT9241B		85	100	115	
Ramp Amplitude			--	1.7	--	V
Ramp Valley			1.0	1.3	--	V
Maximum On Time of Each Channel			70	75	80	%
<b>Reference and DAC</b>						
DACOUT Voltage Accuracy			-1.0	--	+1.0	%
DAC (VID0-VID4) Input Low Voltage			--	--	0.8	V
DAC (VID0-VID4) Input High Voltage			2.0	--	--	V
DAC (VID0-VID4) Bias Current			20	28	36	μA
<b>PWM Controller Error Amplifier</b>						
DC Gain			--	85	--	dB
Bandwidth			--	10	--	MHz
Slew Rate		C <sub>L</sub> = 10pF	--	5	--	V/μs

*To be continued*

Parameter	Symbol	Test Conditions	Min	Typ	Max	Units
<b>Current Sense GM Amplifier</b>						
ISP 1,2 Full Scale Source Current			50	--	--	μA
ISP 1,2 Current for OCP			70	75	--	μA
<b>Protection</b>						
SS Current		$V_{SS} = 1V$	8	13	18	μA
Over-Voltage Trip (VSEN/DACOUT)			118	122	126	%
<b>Power Good</b>						
Upper Threshold (VSEN/DACOUT)		VSEN Rising	106	110	114	%
Lower Threshold (VSEN/DACOUT)		VSEN Rising	86	90	94	%



**Typical Operating Characteristics**

**Over Current Protection at Power-**

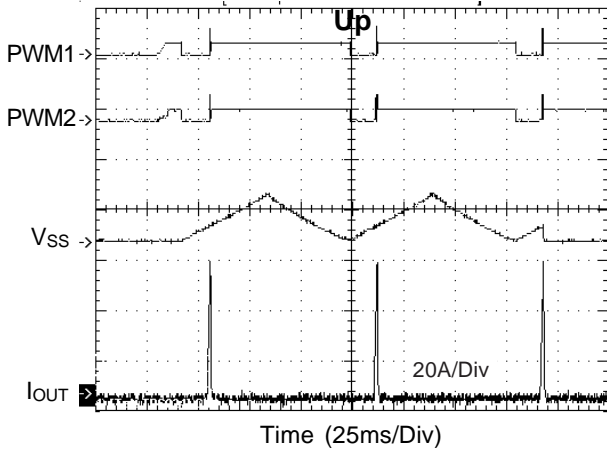

**Over Current Protection at Steady**

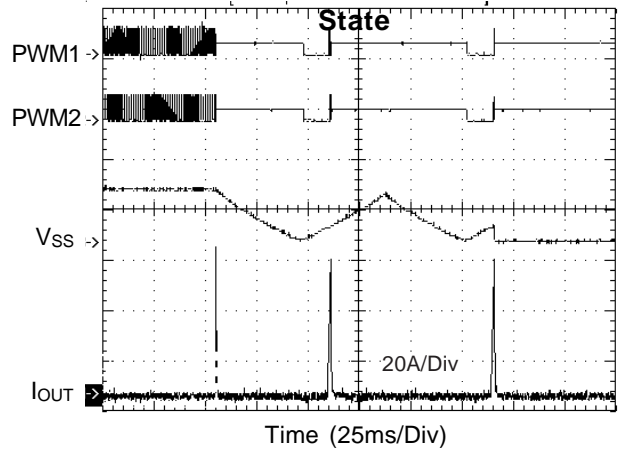

**Current Sharing between Two**

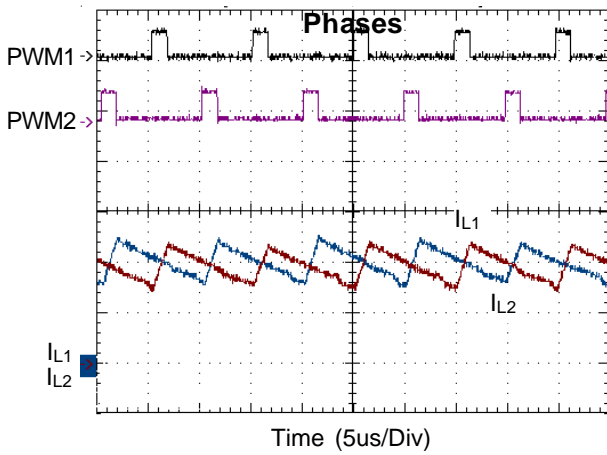

**Two-Phase Converter without Current**

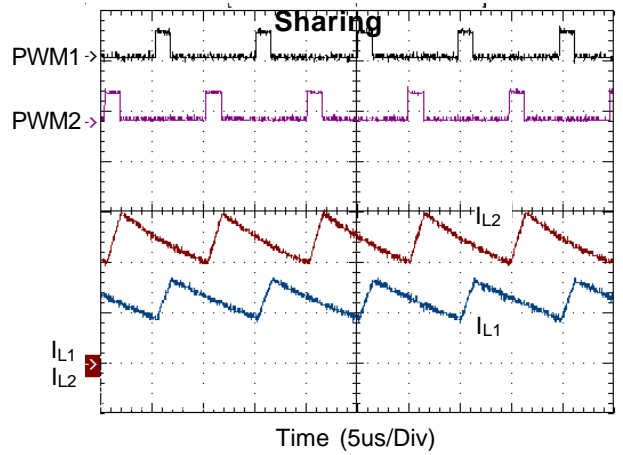

**The Hysteresis of V<sub>DD</sub>**

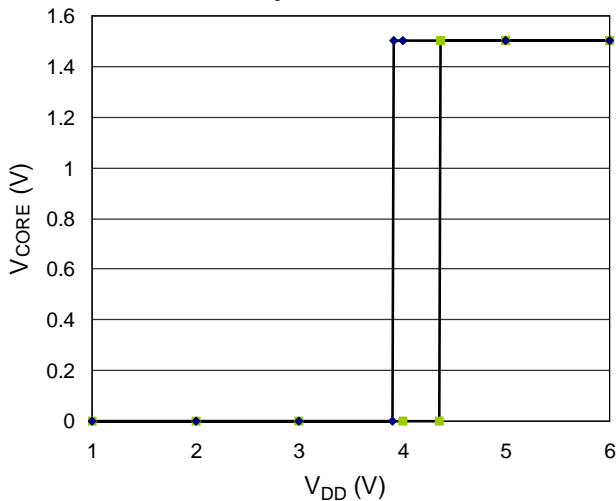

**The Hysteresis of V<sub>DVD</sub>**

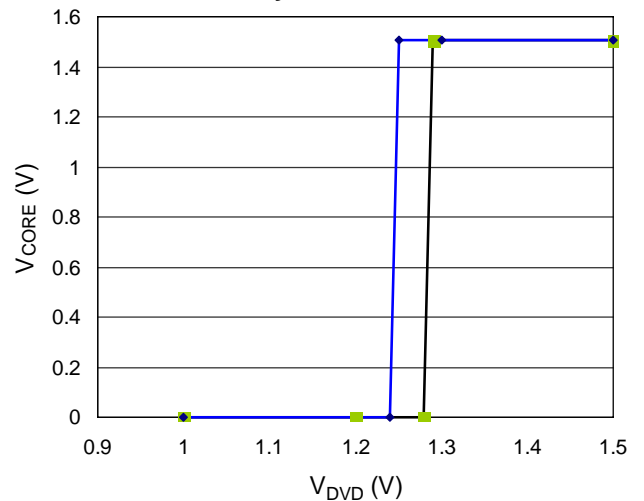

Simplified Block Diagram Control Loops for a Two Phase Converter

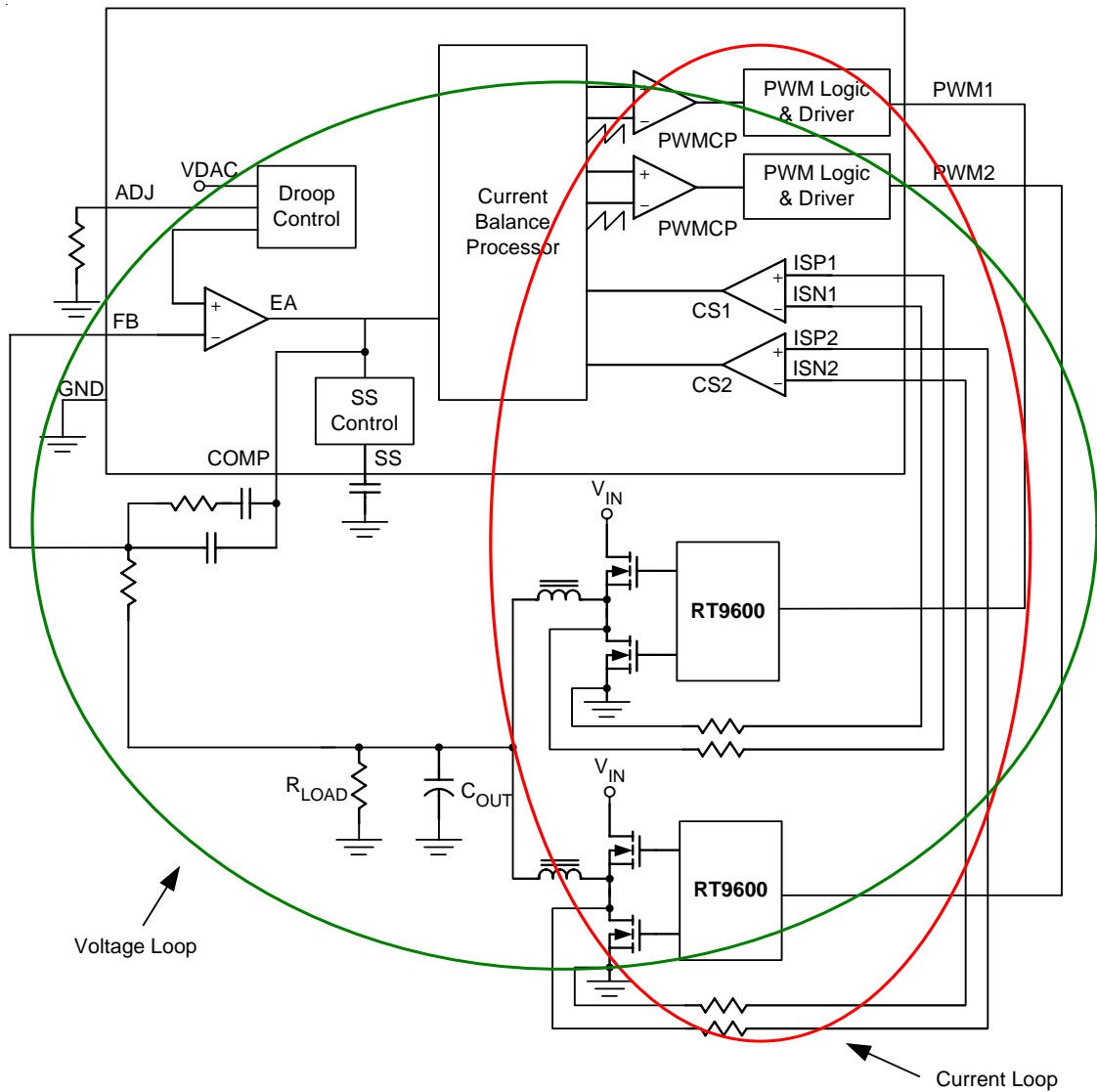

## Application Information

RT9241A/B is a two-phase DC/DC controller that precisely regulates CPU core voltage and balances the current of different power channels. The converter consists of RT9241A/B and its companion MOSFET driver provide high quality CPU power and all protection function to meet the requirement of modern VRM.

### Voltage control

The reference of  $V_{CORE}$  is provided by a 5-bit DAC of VRM9.0 specification. Control loop consists of error amplifier, two-phase pulse width modulator, driver and power components. Like conventional voltage mode PWM controller, the output voltage is locked at the  $V_{REF}$  of error amplifier and the error signal is used as the control signal  $V_C$  of pulse width modulator. The PWM signals of different channels are generated by comparison of EA output and split-phase saw-tooth wave. Power stage transforms  $V_{IN}$  to output by PWM signal on-time ratio.

### Current balance

RT9241A/B senses the current of low side MOSFET in each synchronous rectifier when it is conducting for channel current balance and droop tuning. The differential sensing GM amplifier converts the voltage on the sense component (can be a sense resistor or the  $R_{DS(ON)}$  of the low side MOSFET) to current signal into internal balance circuit. The current balance circuit sums and averages the current signals then produces the balancing signals injected to pulse width modulator. If the current of some power channel is greater than average, the balancing signal reduces the output pulse width to keep the balance.

### Load droop

The sensed power channel current signals regulate the reference of DAC to form a output voltage droop proportional to the load current. The droop or so call "active voltage positioning" can reduce the output voltage ripple at load transient and the LC filter size.

### Fault detection

The chip detects  $V_{CORE}$  for over voltage and power good detection. The "hiccup mode" operation of over current protection is adopted to reduce the short circuit current. The in-rush current at the start up is suppressed by the soft start circuit through clamping the pulse width and output voltage.

### MOSFET driver detection and converter start up

RT9241A/B interface with companion MOSFET driver (like RT9600 or HIP660X series) for correct converter initialization. The tri-phase PWM output (high, low, high impedance) pins sense the interface voltage at IC POR acts (both  $V_{DD}$  and  $V_{DVID}$  trip). The channel is enabled if the pin voltage is 1.2V less than  $V_{DD}$ . Please tie the both PWM output to driver input for correct converter start-up.

### Current sensing setting

RT9241A/B senses the current of low side MOSFET in each synchronous rectifier when it is conducting for channel current balance and droop tuning. The differential sensing GM amplifier converts the voltage on the sense component (can be a sense resistor or the  $R_{DS(ON)}$  of the low side MOSFET) to current signal into internal circuit (see Figure 1).

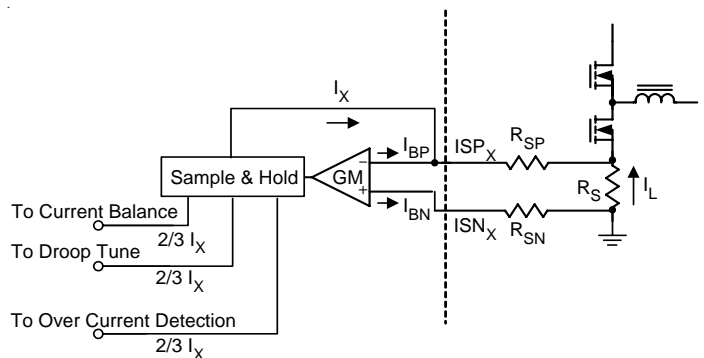

Figure 1. Current Sense Circuit

The sensing circuit gets  $I_x = \frac{I_L \times R_s}{R_{SP}}$  by local feedback.  $R_{SP} = R_{SN}$  to cancel the voltage drop caused by GM amplifier input bias current.  $I_x$  is sampled and held just before low side MOSFET turns off (See Figure 2). Therefore,

$$I_{X(S/H)} = \frac{I_{L(S/H)} \times R_s}{R_{SP}} \quad I_{L(S/H)} = I_{L(AVG)} - \frac{V_o}{L} \times \frac{T_{OFF}}{2}$$

$$T_{OFF} = \left( \frac{V_{IN} - V_o}{V_{IN}} \right) \times T_s, \text{ for switching}$$

period =  $T_s$

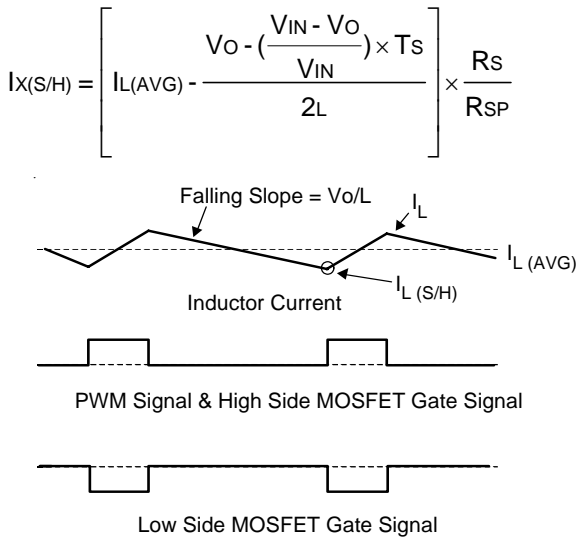

Figure 2. Inductor Current and PWM Signal

**Droop tuning**

The S/H current signals from power channels are injected to ADJ pin to create droop voltage.

$$V_{ADJ} = R_{ADJ} \times \frac{2}{3} \sum I_x$$

The DAC output voltage decreases by  $V_{ADJ}$  to form the  $V_{CORE}$  load droop (see Figure 3).

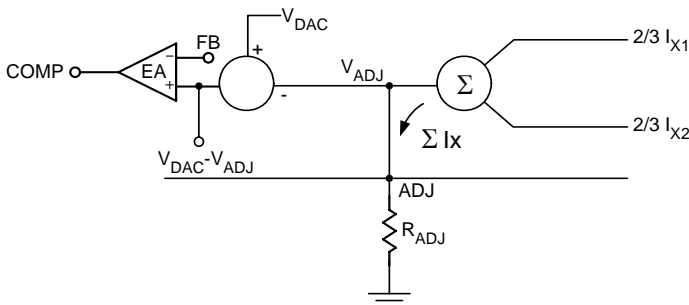

Figure 3. Droop Tune Circuit

**Protection and SS function**

For OVP, the RT9241A/B detects the  $V_{CORE}$  by  $V_{SEN}$  pin. Eliminate the parasitic delay and noise influence on the PCB path for fast and accurate detection. The trip point of OVP is 120% of normal output level. The PWM outputs are pulled low to turn on the low side MOSFET and turn off the high side MOSFET of the synchronous rectifier at OVP. The OVP latch can only be reset by  $V_{DD}$  or  $V_{DVD}$  restart power on reset sequence. The PGOOD detection trip point of  $V_{CORE}$  is  $\pm 8\%$  out of the normal level. The PGOOD open drain output pulls low when  $V_{OCRE}$  exceeds the range.

Soft start circuit generates a ramp voltage by charging external capacitor with 10uA current after IC POR acts. The PWM pulse width and  $V_{CORE}$  are clamped by the rising ramp to reduce the in-rush current and protect the power components.

OCP is triggered if one channel S/H current signal  $I_x > 75\mu A$ . Controller forces PWM output latched at high impedance to turn off both high and low side MOSFET in the power stage and initial the hiccup mode protection. The SS pin voltage is pulled low with a 10uA current after it is less than 90%  $V_{DD}$ . The converter restarts after SS pin voltage  $< 0.2V$ . Three times of OCP disable the converter and only release the latch by POR acts (see Figure 4).

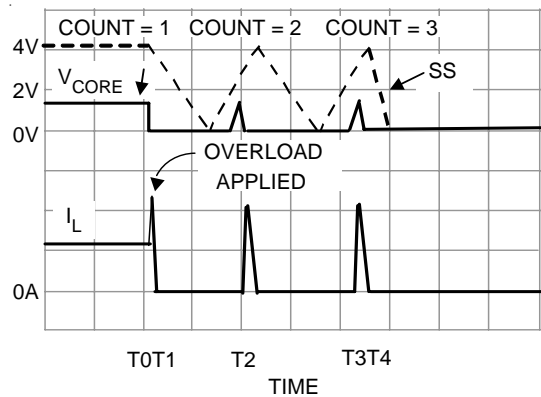
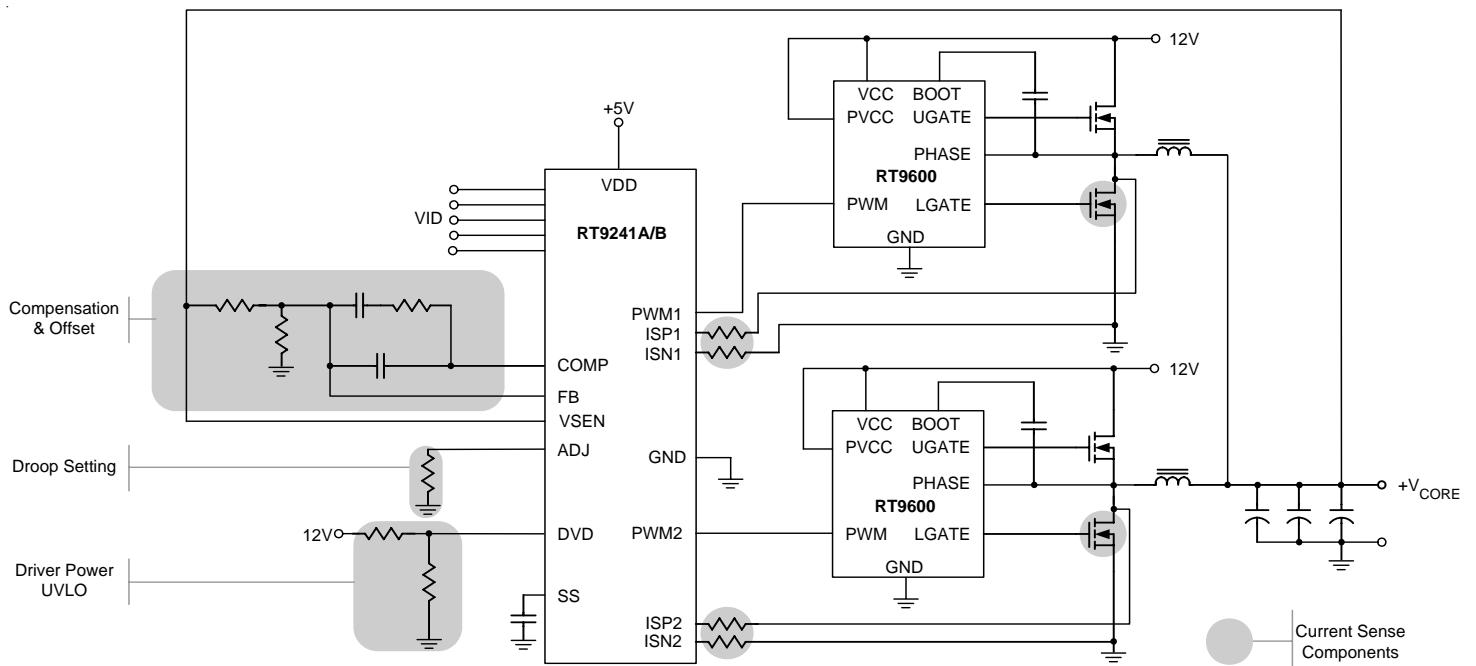

Figure 4

**Two-Phase Converter and Components Function Grouping**



**Design Procedure Suggestion**

**Voltage loop setting**

- a. Output filter pole and zero (Inductor, output capacitor value & ESR)
- b. Error amplifier compensation network

**Current loop setting**

- a. Over current protection trip point setting by GM amplifier S/H current(current sense component Ron, ISP<sub>x</sub> & ISN<sub>x</sub> pin external resistor value, keep ISP<sub>x</sub> current = 75μA at OCP condition)

**VRM load line setting**

- a. Droop amplitude (ADJ pin resistor)
- b. No load offset (additional resistor in compensation network)

**Power sequence & SS**

- DVD pin external resistor and SS pin capacitor
- PCB layout

- a. Kelvin sense for current sense GM amplifier input
- b. Refer to layout guide for other item

**Design Example for RT9241A**

Two phase converter  $V_{CORE} = 1.5V$ ,  $V_{IN} = 12V$ , full load current = 40Amp, droop voltage at full load = 120mV, OCP trip point for each power stage = 30Amp (at Sample/ Hold), low side MOSFET  $R_{DS(ON)} = 6m\Omega$  at room temperature,  $L = 2\mu H$ ,  $C_{OUT} = 9000\mu F$ , capacitor ESR = 2m $\Omega$ .

1. Compensation setting

a. Modulator Gain, Pole and Zero

$$\text{Modulator Gain} = \frac{V_{IN}}{V_{RAMP}}$$

saw-tooth wave amplitude  $V_{RAMP} = 1.7V$ ,

$$\text{modulator Gain} = 8.6 = 18.7\text{dB}$$

$$\text{LC filter pole} = \frac{1}{2\pi\sqrt{LC}} = 1.2\text{kHz}$$

$$\text{ESR zero} = \frac{1}{2\pi C R_{ESR}} = 8.8\text{kHz}$$

b. EA compensation network

Use type 2 compensation scheme (see Figure5)

$$F_z = \frac{1}{2\pi R_2 C_1} \quad F_p = \frac{1}{2\pi R_2 \left( \frac{C_1 \times C_2}{C_1 + C_2} \right)}$$

$$\text{mid-band gain} = \frac{R_2}{R_1} \quad \text{Choose } R_1 = 2.4\text{K}\Omega,$$

$$R_2 = 24\text{K}\Omega, C_1 = 6.6\text{nF}, C_2 = 33\text{pF}, \text{ get } F_z = 1\text{kHz},$$

$$F_p = 200\text{kHz}, \text{ mid-band Gain} = 10 = 20\text{dB}, \text{ modulator}$$

asymptotic Bode plot of EA compensation and PWM

loop Gain Bode shown as Figure 6.

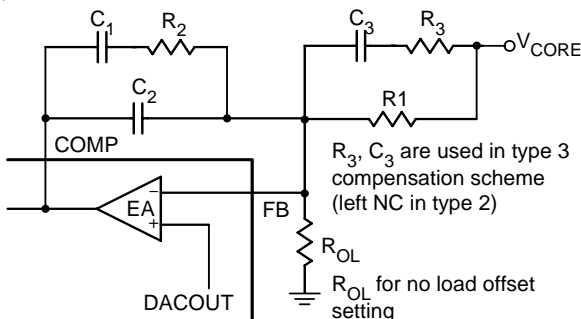

Figure 5. EA Compensation Network

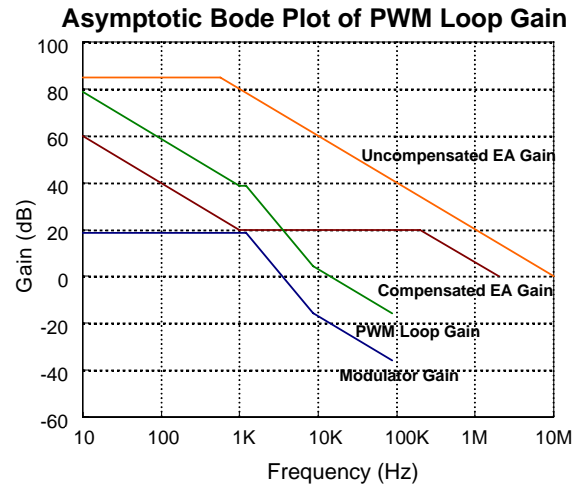

Figure 6. Asymptotic Bode Plot of PWM Loop Gain

2. Over Current Protection setting

OCP trip point current = 30A (at Sample/ Hold),

$$I_X = \frac{R_{DS(ON)} \times 30A}{R_{SP}} = 75\mu A, \quad R_{ISP} = 2.4\text{K}\Omega$$

Take the temperature rising for consideration, if MOSFET

working temperature = 70°C and the temperature

coefficient = 5000ppm/°C,  $R_{ISP}(70^\circ\text{C}) = R_{ISP}(27^\circ\text{C}) \times$

$$\left\{ \frac{R_{DS(ON)}(70^\circ\text{C})}{R_{DS(ON)}(27^\circ\text{C})} \right\} = 1.75\text{K}\Omega$$

3. Droop setting

Full load current of each power channel = 40A/2 =

20Amp, the ripple current =  $\Delta I_L =$

$$5\mu s \times \frac{1.5V}{2\mu H} \times \left( 1 - \frac{1.5V}{12V} \right) = 3.28A$$

$$\text{load current at S/H} \quad 20A - \frac{\Delta I_L}{2} = 18.36A$$

$$= I_{X(MAX)} = \frac{R_{DS(ON)} \times 18.36A}{R_{ISP}}$$

, GM Amp S/H,  $R_{ISP} = R_{ISN} = 2.4\text{K}\Omega$ ,  $I_{X(MAX)} = 46\mu A$ ,

required Droop = 120mV =  $46\mu A \times 2 \times 2/3 \times R_{ADJ}$ ,

$$R_{ADJ} = 1.97\text{K}\Omega.$$

Take the temperature rising for consideration, we just

modify  $R_{ISP}$  like OCP setting.

4. SS capacitor

$C_{SS} = 0.1\mu F$  is the suitable value for most application.

**Layout Guide**

**Layout Guide**

Place the high-power switching components first, and separate them from sensitive nodes.

1. Most critical path: the current sense circuit is the most sensitive part of the converter. The current sense resistors tied to ISP1,2 and ISN1,2, should be located not more than 0.5 inch from the IC and away from the noise switching nodes. The PCB trace of sense nodes should be parallel and as short as possible. Kelvin connection of the sense component (additional sense resistor or MOSFET  $R_{DS(ON)}$ ) ensures the accurate stable current sensing.

No Kelvin sense, no guarantee for stable operation!

Switching ripple current path:

- a. Input capacitor to high side MOSFET
- b. Low side MOSFET to output capacitor
- c. The return path of input and output capacitor
- d. Separate the power and signal GND
- e. The switching nodes (the connection node of high/low side MOSFET and inductor) is the most noisy points. Keep them away from sensitive small-signal node.
- f. Reduce parasitic R, L by minimum length, enough copper thickness and avoiding of via.

2. MOSFET driver should be close to MOSFET

4. The compensation, bypass and other function setting components should be near the IC and away from the noisy power path.

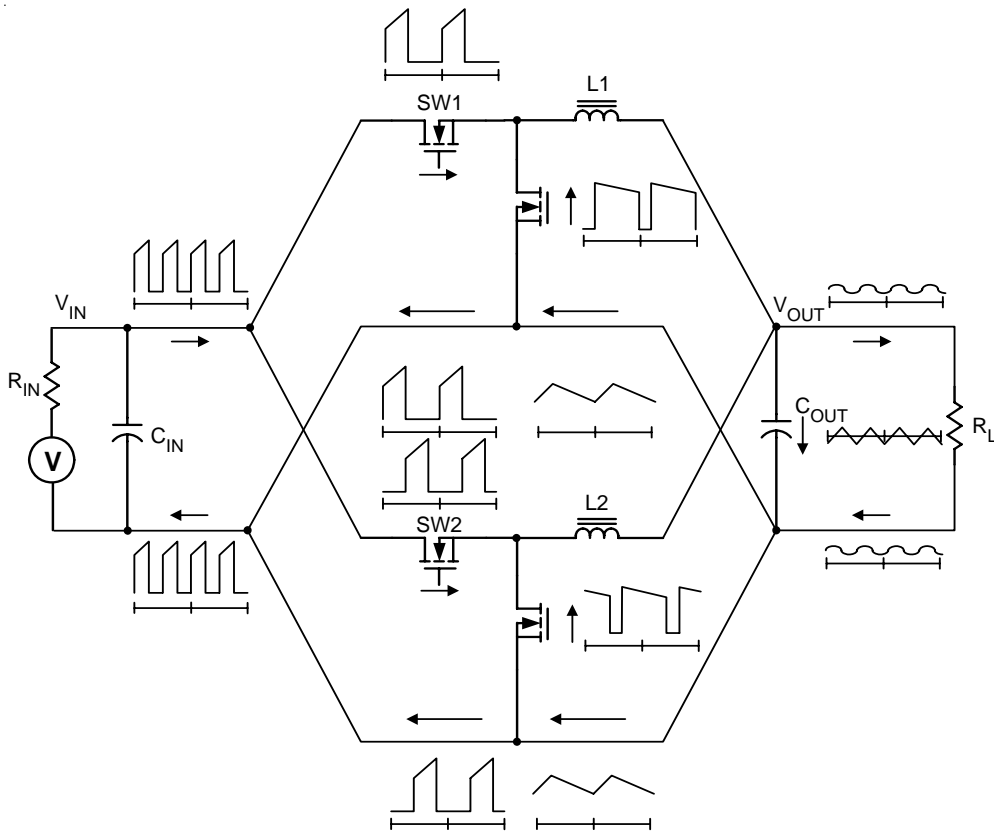

Figure.7 Power Stage Ripple Current Path

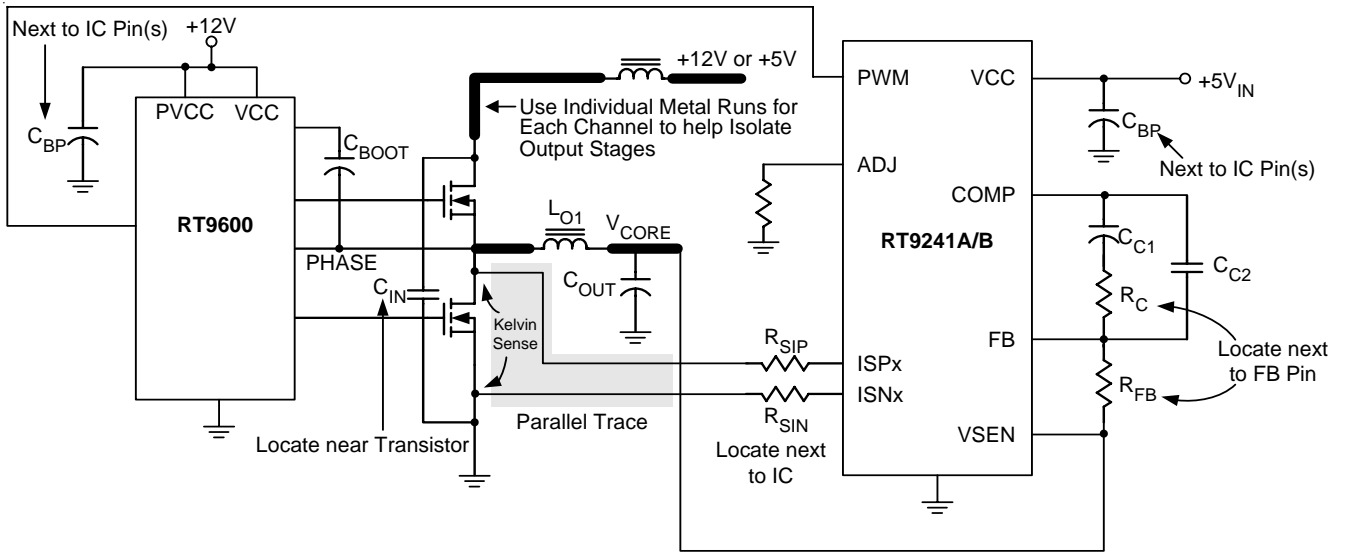
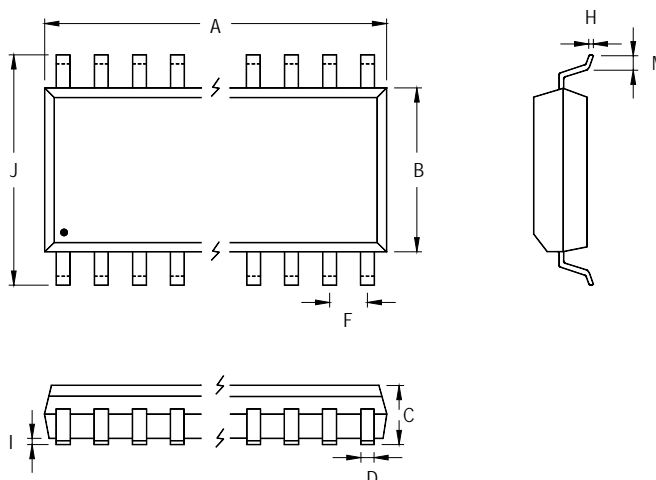

Figure.8 Layout Consideration



**Outline Dimension**



Symbol	Dimensions In Millimeters		Dimensions In Inches	
	Min	Max	Min	Max
A	12.598	13.005	0.496	0.512
B	7.391	7.595	0.291	0.299
C	2.362	2.642	0.093	0.104
D	0.330	0.508	0.013	0.020
F	1.194	1.346	0.047	0.053
H	0.229	0.330	0.009	0.013
I	0.102	0.305	0.004	0.012
J	10.008	10.643	0.394	0.419
M	0.381	1.270	0.015	0.050

**20-Lead SOP Plastic Package**

**Richtek Technology Corporation**

Headquarter  
 5F, No. 20, Taiyuen Street, Chupei City  
 Hsinchu, Taiwan, R.O.C.  
 Tel: (8863)5526789 Fax: (8863)5526611

**Richtek Technology Corporation**

Taipei Office (Marketing)  
 8F, No. 137, Lane 235, Paochiao Road, Hsintien City  
 Taipei County, Taiwan, R.O.C.  
 Tel: (8862)89191466 Fax: (8862)89191465  
 Email: marketing@richtek.com