



VT82C694X Apollo Pro133A

66 / 100 / 133 MHz

**Single-Chip Slot-1 / Socket-370 North Bridge
for Desktop and Mobile PC Systems
with AGP 4x and PCI
plus Advanced ECC Memory Controller
supporting PC133 / PC100 SDRAM,
Virtual Channel Memory (VCM), & ESDRAM**

Revision 1.01
November 2, 1999

VIA TECHNOLOGIES, INC.

Copyright Notice:

Copyright © 1997, 1998, 1999 VIA Technologies Incorporated. Printed in the United States. ALL RIGHTS RESERVED.

No part of this document may be reproduced, transmitted, transcribed, stored in a retrieval system, or translated into any language, in any form or by any means, electronic, mechanical, magnetic, optical, chemical, manual or otherwise without the prior written permission of VIA Technologies Incorporated.

VT82C585, VT82C586B, VT82C587, VT82C590, VT82C595, VT82C596B, VT82C597, VT82C598, VT8501, VT82C680, VT82C685, VT82C686A, VT82C687, VT82C596A, VT82C691, VT82C692, VT82C693, VT82C693A, VT82C694, VT82C694A, VT82C694X, VT8601, Mobile South, Super South, Apollo VP, Apollo VPX, Apollo VP2, Apollo VP3, Apollo MVP3, Apollo MVP4, Apollo P6, Apollo Pro, Apollo ProPlus, Apollo Pro133, Apollo Pro133A, and Apollo ProMedia may only be used to identify products of VIA Technologies.

Cyrix6x86™ is a registered trademark of VIA Technologies.

AMD6x86™, AMD-K6™, and Athlon™ are registered trademarks of Advanced Micro Devices Corp.

Pentium™, P54C™, P55C™, and MMX™ are registered trademarks of Intel Corp.

PS/2™ is a registered trademark of International Business Machines Corp.

Windows 95™, Windows 98™, and Plug and Play™ are registered trademarks of Microsoft Corp.

PCI™ is a registered trademark of the PCI Special Interest Group.

VESA™ is a trademark of the Video Electronics Standards Association.

All trademarks are the properties of their respective owners.

Disclaimer Notice:

No license is granted, implied or otherwise, under any patent or patent rights of VIA Technologies. VIA Technologies makes no warranties, implied or otherwise, in regard to this document and to the products described in this document. The information provided by this document is believed to be accurate and reliable to the publication date of this document. However, VIA Technologies assumes no responsibility for any errors in this document. Furthermore, VIA Technologies assumes no responsibility for the use or misuse of the information in this document and for any patent infringements that may arise from the use of this document. The information and product specifications within this document are subject to change at any time, without notice and without obligation to notify any person of such change.

Offices:

USA Office:

1045 Mission Court
Fremont, CA 94539
USA
Tel: (510) 683-3300
Fax: (510) 683-3301

Taipei Office:

8th Floor, No. 533
Chung-Cheng Road, Hsin-Tien
Taipei, Taiwan ROC
Tel: (886-2) 2218-5452
Fax: (886-2) 2218-5453

Online Services:

Home Page: <http://www.via.com.tw> (Taiwan) –or- <http://www.viatech.com> (USA)

FTP Server: <ftp.via.com.tw> (Taiwan)

BBS: 886-2-2185208

REVISION HISTORY

Document Release	Date	Revision	Initials
0.3	1/5/99	Initial internal release as VT82C694A based on 694A2X rev 0.3	DH
0.31	1/6/99	Fixed minor typo in AGP feature bullets	DH
0.4	2/1/99	Changed part number to VT82C694X Updated pinouts to match engineering document rev 0.9 dated 1/29/99 Updated register definitions: Device 0 Rx50[5, 3-1], Rx51[5], Rx53[5-3], Rx69[7-5, 1], Rx6B[5, 3-1], Rx6C[4], Rx73[4], Rx76[7], Rx79[1-0], Rx7A[3], RxFC Updated mechanical spec to 502-pin BGA	DH
0.5	3/29/99	Fixed feature bullets: AGP 4x mode support, 6 banks of DIMMs, BGA504 Changed product name to Pro133AX Added GND pins Y7 and Y8 and removed GND on AD5 Moved PCKRUN# from AC4 to AD5; added Suspend Power VSUS on AC4 Added RxAD[4] Updated mechanical spec to reflect change from 502BGA to 504BGA	DH
0.61	5/28/99	Changd product name to Pro133A Added PCI 33/66 configuration strap on MAB5# Fixed pin descriptions: GCKRUN# pin # (typo), NCOMP connect to VCCQ Added Device 0 Rx54, 7B, AE, B0-B1, E0, FD and Device 1 Rx1B, 45, 80-87 Modified Device 0 Rx6[6], 8, 52[5], 53[2-0], 54[7-6], 68[1-0], 69[7-6], 6D[7], 70[3], 72[7], 73[4], 74[6, 76[5-4], 7A[4], A4[2,4,5], A7, A8[2,4,5], AC[0], FC[1] and Device 1 Rx3-2, 42[0]	DH
0.7	6/17/99	Updated pinouts, mechanical specs, and feature bullets to 510 BGA Pins added: K7, L7, R7, U7, AA11, AA12 Pins changed: U6, W6, Y6, AC4, AD4, AD5 Fixed polarity of memory interface CKE and DQM pin names Fixed typos in ball diagram on MAB14# and MAA14 Changed default signal names to match SDRAM instead of EDO (swapped "CAS" with "DQM" and "RAS" with "CS") Added ESDRAM to title Fixed # of banks supported in memory controller feature bullets Fixed register definitions: Device 0 Rx56-57 and 5A-5F bank ending addresses	DH
0.8	7/7/99	Fixed CPURSTD# pin definition, and VCCQ and AGPREF pin descriptions Fixed Device 0 Rx8 default, A2 default, A7 default, AC[7]definition, FD[4-0]	DH
0.81	7/9/99	Fixed Device 1 Rx2-3 Device ID	DH
0.9	8/27/99	Removed "Preliminary" from doc revision & fixed document formatting errors Fixed minor typos in pin descriptions GDS[1:0]#, SBS#, GWBF#, GCKRUN# Fixed Device 0 Rx10[27:20] and 88[2] and Device 1 Rx40[3] bit definitions Added "Case Operating Temp" spec and fixed ambient & AC conditions temps	DH
1.0	9/8/99	Final document release with "NDA Required" removed Fixed register reference in MECC pin descriptions Fixed Device 0 Rx6[7], Rx7A[3]	DH
1.01	11/2/99	Changed Device 0 Rx68[0] to don't care for CPU FSB Frequency of 133 MHz Updated logo to "Delivering Value" format	DH

TABLE OF CONTENTS

REVISION HISTORY	I
TABLE OF CONTENTS	II
LIST OF FIGURES	III
LIST OF TABLES	IV
APOLLO PRO133A	1
OVERVIEW	4
PINOUTS – VT82C694X APOLLO PRO133A	6
PIN DESCRIPTIONS	9
REGISTERS	17
REGISTER OVERVIEW	17
MISCELLANEOUS I/O	20
CONFIGURATION SPACE I/O	20
REGISTER DESCRIPTIONS	21
Device 0 Header Registers - Host Bridge	21
Device 0 Configuration Registers - Host Bridge	23
Host CPU Control.....	23
DRAM Control	25
PCI Bus Control.....	32
GART / Graphics Aperture Control	36
AGP Control	38
Device 1 Header Registers - PCI-to-PCI Bridge	41
Device 1 Configuration Registers - PCI-to-PCI Bridge	43
AGP Bus Control	43
ELECTRICAL SPECIFICATIONS	46
ABSOLUTE MAXIMUM RATINGS	46
DC CHARACTERISTICS	46
AC TIMING SPECIFICATIONS	46
MECHANICAL SPECIFICATIONS	47

LIST OF FIGURES

FIGURE 1. APOLLO PRO133A SYSTEM BLOCK DIAGRAM USING THE VT82C596B MOBILE SOUTH BRIDGE ..	4
FIGURE 2. <u>VT82C694X</u> BALL DIAGRAM (TOP VIEW).....	6
FIGURE 3. <u>VT82C694X</u> PIN LIST (NUMERICAL ORDER)	7
FIGURE 4. <u>VT82C694X</u> PIN LIST (<u>ALPHABETICAL</u> ORDER).....	8
FIGURE 5. GRAPHICS APERTURE ADDRESS TRANSLATION	36
FIGURE 6. MECHANICAL SPECIFICATIONS - 510-PIN BALL GRID ARRAY PACKAGE	47

LIST OF TABLES

TABLE 1. VT82C694X PIN DESCRIPTIONS.....	9
TABLE 2. VT82C694X REGISTERS	17
TABLE 3. SYSTEM MEMORY MAP.....	25
TABLE 4. MEMORY ADDRESS MAPPING TABLE	25
TABLE 5. VGA/MDA MEMORY/IO REDIRECTION.....	43
TABLE 6. AC TIMING MIN / MAX CONDITIONS.....	46

VIA VT82C694X APOLLO PRO133A

66 / 100 /133 MHz

Single-Chip Slot-1 / Socket-370 North Bridge
for Desktop and Mobile PC Systems
with AGP 4x and PCI
plus Advanced ECC Memory Controller
supporting PC133 / PC100 SDRAM,
Virtual Channel Memory (VCM), and ESDRAM

- **AGP / PCI / ISA Mobile and Deep Green PC Ready**

- GTL+ compliant host bus supports write-combine cycles
- Supports separately powered 3.3V (5V tolerant) interface to system memory, AGP, and PCI bus
- Modular power management and clock control for mobile system applications
- Combine with VIA VT82C596B south bridge chip for state-of-the-art system power management

- **High Integration**

- Single chip implementation for 64-bit Slot-1/Socket-370 CPU, 64-bit system memory, 32-bit PCI and 32-bit AGP interfaces
- **Apollo Pro133A** Chipset: **VT82C694X** system controller and **VT82C596B** PCI to ISA bridge
- Chipset includes UltraDMA-33/66 EIDE, USB, and Keyboard / PS2-Mouse Interfaces plus RTC / CMOS on chip

- **High Performance CPU Interface**

- Supports Slot-1 and Socket-370 (Intel Pentium II™ and Celeron™) processors
- 66 / 100 /133 MHz CPU Front Side Bus (FSB)
- Built-in PLL (Phase Lock Loop) circuitry for optimal skew control within and between clocking regions
- Five outstanding transactions (four In-Order Queue (IOQ) plus one input latch)
- Supports WC (Write Combining) cycles
- Dynamic deferred transaction support
- Sleep mode support
- System management interrupt, memory remap and STPCLK mechanism

• **Full Featured Accelerated Graphics Port (AGP) Controller**

- Synchronous and pseudo-synchronous with the host CPU bus with optimal skew control

<u>PCI</u>	<u>AGP</u>	<u>CPU</u>	<u>Mode</u>
33 MHz	66 MHz	133 MHz	4x synchronous
33 MHz	66 MHz	100 MHz	3x synchronous
33 MHz	66 MHz	66 MHz	2x synchronous
- AGP v2.0 compliant
- Supports SideBand Addressing (SBA) mode (non-multiplexed address / data)
- Supports 266 MHz 4x mode for AD and SBA signaling
- Pipelined split-transaction long-burst transfers up to 1GB/sec
- Eight level read request queue
- Four level posted-write request queue
- Thirty-two level (quadwords) read data FIFO (256 bytes)
- Sixteen level (quadwords) write data FIFO (128 bytes)
- Intelligent request reordering for maximum AGP bus utilization
- Supports Flush/Fence commands
- Graphics Address Relocation Table (GART)
 - One level TLB structure
 - Sixteen entry fully associative page table
 - LRU replacement scheme
 - Independent GART lookup control for host / AGP / PCI master accesses
- Windows 95 OSR-2 VXD and integrated Windows 98 / NT5 miniport driver support

• **Concurrent PCI Bus Controller**

- PCI buses are synchronous / pseudo-synchronous to host CPU bus
- 33 MHz operation on the primary PCI bus
- 66 MHz PCI operation on the AGP bus
- PCI-to-PCI bridge configuration on the 66MHz PCI bus
- Supports up to five PCI masters
- Peer concurrency
- Concurrent multiple PCI master transactions; i.e., allow PCI masters from both PCI buses active at the same time
- Zero wait state PCI master and slave burst transfer rate
- PCI to system memory data streaming up to 132Mbyte/sec
- PCI master snoop ahead and snoop filtering
- Two lines of CPU to PCI posted write buffers
- Byte merging in the write buffers to reduce the number of PCI cycles and to create further PCI bursting possibilities
- Enhanced PCI command optimization (MRL, MRM, MWI, etc.)
- Forty-eight levels (double-words) of post write buffers from PCI masters to DRAM
- Sixteen levels (double-words) of prefetch buffers from DRAM for access by PCI masters
- Delay transaction from PCI master accessing DRAM
- Read caching for PCI master reading DRAM
- Transaction timer for fair arbitration between PCI masters (granularity of two PCI clocks)
- Symmetric arbitration between Host/PCI bus for optimized system performance
- Complete steerable PCI interrupts
- PCI-2.1 compliant, 32 bit 3.3V PCI interface with 5V tolerant inputs

- **Advanced High-Performance DRAM Controller**

- DRAM interface synchronous with host CPU (66/100/133 MHz) or AGP (66MHz) for most flexible configuration
- DRAM interface may be faster than CPU by 33 MHz to allow use of PC100 memory modules with 66MHz Celeron or use of PC133 with 100MHz Pentium II or Pentium III
- DRAM interface may be slower than CPU by 33 MHz to allow use of older memory modules with newer CPUs (e.g., PC66 memory modules with 100 MHz Pentium II or Pentium III)
- Concurrent CPU, AGP, and PCI access
- Supports FP, EDO, SDRAM, ESDRAM, and VCM SDRAM memory types
- Different DRAM types may be used in mixed combinations
- Different DRAM timing for each bank
- Dynamic Clock Enable (CKE) control for SDRAM power reduction in high speed systems
- Mixed 1M / 2M / 4M / 8M / 16M / 32MxN DRAMs
- Pinouts support 8 banks up to 2 GB DRAMs (256Mb DRAM technology) at 100 MHz (PC133 specifications, however, recommend a limit of 3 DIMMs or 6 banks at 133 MHz for 1.5 GB max memory)
- Flexible row and column addresses
- 64-bit data width only
- 3.3V DRAM interface with 5V-tolerant inputs
- Programmable I/O drive capability for MA, command, and MD signals
- Dual copies of MA signals for improved drive
- Optional bank-by-bank ECC (single-bit error correction and multi-bit error detection) or EC (error checking only) for DRAM integrity
- Two-bank interleaving for 16Mbit SDRAM support
- Two-bank and four bank interleaving for 64Mbit SDRAM support
- Supports maximum 8-bank interleave (i.e., 8 pages open simultaneously); banks are allocated based on LRU
- Independent SDRAM control for each bank
- Seamless DRAM command scheduling for maximum DRAM bus utilization (e.g., precharge other banks while accessing the current bank)
- Four cache lines (16 quadwords) of CPU to DRAM write buffers
- Four cache lines of CPU to DRAM read prefetch buffers
- Read around write capability for non-stalled CPU read
- Speculative DRAM read before snoop result
- Burst read and write operation
- x-2-2-2-2-2-2 back-to-back accesses for EDO DRAM from CPU or from DRAM controller
- x-1-1-1-1-1-1 back-to-back accesses for SDRAM
- BIOS shadow at 16KB increment
- Decoupled and burst DRAM refresh with staggered RAS timing
- CAS before RAS or self refresh

- **Advanced System Power Management Support**

- Dynamic power down of SDRAM (CKE)
- Independent clock stop controls for CPU / SDRAM, AGP, and PCI bus
- PCI and AGP bus clock run and clock generator control
- VTT suspend power plane preserves memory data
- Suspend-to-DRAM and Self-Refresh operation
- EDO self-refresh and SDRAM self-refresh power down
- 8 bytes of BIOS scratch registers
- Low-leakage I/O pads

- **Built-in NAND-tree pin scan test capability**

- **3.3V, 0.35um, high speed / low power CMOS process**

- **35 x 35 mm, 510 pin BGA Package**

OVERVIEW

The *Apollo Pro133A (VT82C694X)* is a high performance, cost-effective and energy efficient chip set for the implementation of AGP / PCI / ISA desktop personal computer systems from 66 MHz, 100 MHz and 133 MHz based on 64-bit Socket-370 and Slot-1 (Intel Pentium-II and Celeron) super-scalar processors.

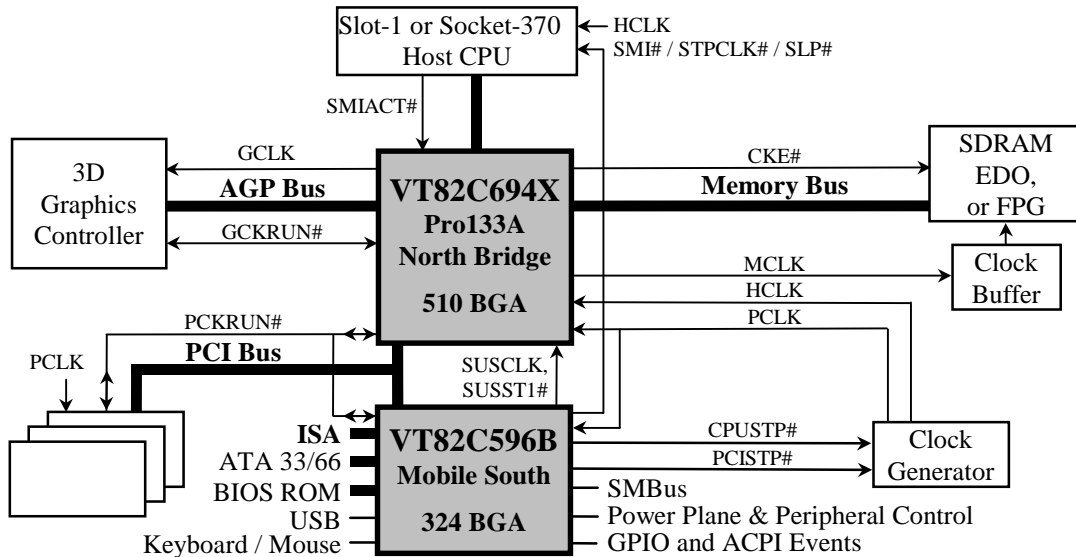

Figure 1. Apollo Pro133A System Block Diagram Using the VT82C596B Mobile South Bridge

The Apollo Pro133A chip set consists of the VT82C694X system controller (510 pin BGA) and the VT82C596B PCI to ISA bridge (324 pin BGA). The system controller provides superior performance between the CPU, DRAM, AGP bus, and PCI bus with pipelined, burst, and concurrent operation.

The VT82C694X supports eight banks of DRAMs up to 1.5GB. The DRAM controller supports standard Fast Page Mode (FPM) DRAM, EDO-DRAM, Synchronous DRAM (SDRAM) and Virtual Channel SDRAM (VC SDRAM), in a flexible mix / match manner. The Synchronous DRAM interface allows zero wait state bursting between the DRAM and the data buffers at 66/100/133 MHz. The eight banks of DRAM can be composed of an arbitrary mixture of 1M / 2M / 4M / 8M / 16M / 32MxN DRAMs. The DRAM controller also supports optional ECC (single-bit error correction and multi-bit detection) or EC (error checking) capability separately selectable on a bank-by-bank basis. The DRAM controller can run at either the host CPU bus frequency (66 /100 /133 MHz) or at the AGP bus frequency (66 MHz) with built-in PLL timing control.

The VT82C694X system controller also supports full AGP v2.0 capability for maximum bus utilization including 2x and 4x mode transfers, SBA (SideBand Addressing), Flush/Fence commands, and pipelined grants. An eight level request queue plus a four level post-write request queue with thirty-two and sixteen quadwords of read and write data FIFO's respectively are included for deep pipelined and split AGP transactions. A single-level GART TLB with 16 full associative entries and flexible CPU / AGP / PCI remapping control is also provided for operation under protected mode operating environments. Both Windows-95 VXD and Windows-98 / NT5 miniport drivers are supported for interoperability with major AGP-based 3D and DVD-capable multimedia accelerators.

The VT82C694X supports two 32-bit 3.3 / 5V system buses (one AGP and one PCI) that are synchronous / pseudo-synchronous to the CPU bus. The chip also contains a built-in bus-to-bus bridge to allow simultaneous concurrent operations on each bus. Five levels (doublewords) of post write buffers are included to allow for concurrent CPU and PCI operation. For PCI master operation, forty-eight levels (doublewords) of post write buffers and sixteen levels (doublewords) of prefetch buffers are included for concurrent PCI bus and DRAM/cache accesses. The chip also supports enhanced PCI bus commands such as Memory-Read-Line, Memory-Read-Multiple and Memory-Write-Invalid commands to minimize snoop overhead. In addition, advanced features are supported such as snoop ahead, snoop filtering, L1 write-back forward to PCI master, and L1 write-back merged with PCI post

write buffers to minimize PCI master read latency and DRAM utilization. Delay transaction and read caching mechanisms are also implemented for further improvement of overall system performance.

The 324-pin Ball Grid Array VT82C596B PCI to ISA bridge supports four levels (doublewords) of line buffers, type F DMA transfers and delay transaction to allow efficient PCI bus utilization and (PCI-2.1 compliant). The VT82C596B also includes an integrated keyboard controller with PS2 mouse support, integrated DS12885 style real time clock with extended 256 byte CMOS RAM, integrated master mode enhanced IDE controller with full scatter / gather capability and extension to UltraDMA-33/66 for 33/66 MB/sec transfer rate, integrated USB interface with root hub and two function ports with built-in physical layer transceivers, Distributed DMA support, and OnNow / ACPI compliant advanced configuration and power management interface.

For sophisticated power management, the Apollo Pro133A provides independent clock stop control for the CPU / SDRAM, PCI, and AGP buses and Dynamic CKE control for powering down of the SDRAM. A separate suspend-well plane is implemented for the SDRAM control signals for Suspend-to-DRAM operation. Coupled with the VT82C596B south bridge chip, a complete power conscious PC main board can be implemented with no external TTLs.

The Apollo Pro133A chipset is ideal for high performance, high quality, high energy efficient and high integration desktop and notebook AGP / PCI / ISA computer systems.

PINOUTS – VT82C694X APOLLO PRO133A

Figure 2. VT82C694X Ball Diagram (Top View)

Key	1	2	3	4	5	6	7	8	9	10	11	12	13	14	15	16	17	18	19	20	21	22	23	24	25	26		
A	GND	AD20	REQ0#	AD25	AD29	RESET#	HD56#	HD62#	HD55#	HD54#	HD49#	HD47#	HD40#	GND	HD33#	HD31#	HD27#	HD19#	HD20#	HD10#	HD6#	HD3#	HA29#	HA24#	HA22#	GND		
B	VCC	PCLK	AD22	AD27	AD28	PREQ#	HD50#	HD61#	HD63#	HD53#	HD48#	HD42#	HD36#	HD43#	HD32#	HD29#	HD25#	HD21#	HD18#	HD12#	HD8#	HD0#	CPU RST#	HA27#	HA20#	BREQ 0#		
C	AD19	VCC	AD21	CBE3#	GND	AD31	REQ1#	HD52#	GND	HD60#	HD59#	HD51#	HD44#	HD37#	HD28#	HD26#	HD22#	GND	HD17#	HD7#	HD5#	GND	HA26#	HA28#	HA23#	HA21#		
D	AD16	AD18	AD17	AD23	AD26	PGNT#	GNT1#	REQ3#	HD58#	REQ4#	HD46#	HD41#	HD39#	HD34#	HD35#	HD30#	HD24#	HD16#	HD15#	HD14#	HD4#	HD1#	HA31#	HA25#	HA18#	HA19#		
E	FRM#	IRDY#	GND	CBE2#	AD24	AD30	GNT0#	GNT3#	GNT4#	GNT2#	HD57#	GND	HD45#	HD38#	GND	GTL REF	HD23#	HD13#	HD11#	HD9#	HD2#	HA30#	HA15#	GND	HA17#	HA16#		
F	SERR#	LOCK#	DEV SEL#	STOP#	TRDY#	GND	VCC	GND	VCC	REQ2#	11	12	13	14	15	16	VTT	VCC	GND	VCC	GND	HA11#	HA12#	HA13#	HA14#	HA8#		
G	AD13	AD14	CBE1#	AD15	PAR	VCC	G7	8	9	10							17	18	19	G20	VCC	HA10#	HA5#	HA7#	HA3#	HA9#		
H	AD8	AD7	AD10	AD12	AD11	GND	H													H	GND	HA4#	HA6#	BNR#	H TRDY#	BPRI#		
J	AD5	AD6	GND	CBE0#	AD9	VCC	J													J	VCC	HREQ 0#	HREQ 1#	GND	HREQ 4#	DEFER#		
K	GND	AD1	AD3	AD2	AD4	AD0	GND	K	PCI Pins	K10	11	12	13	14	15	16	K17			K	CPU Pins	ADS#	HLOCK#	DRDY#	HREQ 2#	HREQ 3#	RS0#	
L	ST1	SBA0	GGNT#	ST0	GREQ#	VCCQ	VCCQ	L		L	VCC	GND	VCC	VCC	GND	VCC	L			L		L	HITM#	DBSY#	HIT#	RS2#	RS1#	
M	SBA2	SBA1	GPIPE#	ST2	SBS#	GWBF#	M			M	GND	VCC	GND	GND	VCC	GND	M			M		M	GND	GND	GTL REF	VTT	TEST IN#	CPU RSTD#
N	AGP REF	SBA3	SBS	GCLKO	GCLK	GRBF#	GND	N		N	VCC	GND	GND	GND	GND	VCC	N			N		N	VCCA	VCCA	HCLK	GND	MD63	VCC
P	SBA7	SBA6	GND	SBA4	SBA5	GD30	GND	P		P	VCC	GND	GND	GND	GND	VCC	P			P		P	GND	MD62	MD30	MD31	GND	
R	GD31	GD29	VCCQ	GD27	GD24	VCCQ	VCCQ	R		R	GND	VCC	GND	GND	VCC	GND	R			R		R	GND	MD28	MD60	MD61	MD29	
T	GD26	GD23	GBE3#	GD20	GDS1#	GDS1	T			T	VCC	GND	VCC	VCC	GND	VCC	T			T		T	MD57	MD58	MD25	MD26	MD59	
U	GD22	GD25	GD19	GD18	GDS0#	GND	GND	U	AGP Pins	U10	11	12	13	14	15	16	U17			U	DRAM Pins	MD27	MD22	MD56	MD55	MD23	MD24	
V	GD17	GD16	GD28	G STOP#	GBE2#	VCCA	V			V	VCC	GND	VCC	VCC	GND	VCC	V			V		V	VCC	MD19	MD20	GND	MD21	MD54
W	GD21	G FRM#	GI RDY#	GD15	GDEV SEL#	VCCQ	W7	8		W							W			W		W	GND	MD18	MD50	MD51	MD53	MD52
Y	GP/AR /GCR#	GT RDY#	GND	GBE1#	GDS0	GND	GND	GND	9	10	11	12					17	18	19	Y20	VCCA	MECC3	MD16	MD48	MD49	MD17		
AA	GD13	GD12	VCCQ	GD11	GD9	GND	VCCQ	GND	VCC	MECC5	VSUS	SUST#	13	14	15	16	SRAS B#	VCC	GND	VCC	GND	DQM A2#	MECC6	DQM A3#	MECC2	MECC7		
AB	GD8	GD10	GBE0#	GD7	GD0	MD2	MD37	MD40	MD41	MD44	MD14	GND	SCAS B#	CS A0#	GND	MA A1	MA B3#	MA B6#	MA B7#	MA B10	DCLK O	DCKR/ MAA14	CS B5#	GND	GND	DQM A7#		
AC	GD6	GD4	GD5	GND	MD0	MD3	MD38	MD7	MD42	MD45	MD15	SWEB#	DQM A5#	DQM A1#	CS A3#	MA B1#	MA A3	MA A7	MA A8	MA B9#	MA A12	CKE0	CKE4	CS B3#	DQM A6#	CS B4#		
AD	GD14	GD3	GD2	VCC QO	GND QO	MD35	MD5	MD8	GND	MD12	MD47	MECC1	DQM A4#	DQM B1#	CS A4#	MA B0#	MA B2#	GND	MA B5#	MA A10	MA B12#	GND	CKE3	CS B1#	DCLK WR	CS B2#		
AE	GD1	NCOMP	WSC#	MD33	MD1	MD36	MD6	MD10	MD43	MD13	MECC4	SWEA#	DQM B5#	DQM A0#	CS A2#	CS A5#	MA A2	MA B4#	MA A5	MA A9	MA B11#	MA B14#	GND	CKE2	CS B0#	VCC		
AF	GND	PCOMP	PWR OK	MD32	MD34	MD4	MD39	MD9	MD11	MD46	MECC0	SCAS A#	GND	VCC	CS A1#	SRAS A#	MA A0	MA A4	MA A6	MA B8#	MA A11	MA B13#	CKE1	CKE5	MA A13	GND		

Figure 3. VT82C694X Pin List (Numerical Order)

Pin #	Pin Name	Pin #	Pin Name	Pin #	Pin Name	Pin #	Pin Name	Pin #	Pin Name	Pin #	Pin Name
A01	P GND	D02	IO AD18	G23	IO HA05#	P02	I SBA6	Y21	P VCCA	AC26	O CSB4# / RASB4#
A02	IO AD20	D03	IO AD17	G24	IO HA07#	P03	P GND	Y22	IO MECC3	AD01	IO GD14
A03	I REQ0#	D04	IO AD23	G25	IO HA03#	P04	I SBA4	Y23	IO MD16	AD02	IO GD03
A04	IO AD25	D05	IO AD26	G26	IO HA09#	P05	I SBA5	Y24	IO MD48	AD03	IO VCCO
A05	IO AD29	D06	O PGNT#	H01	IO AD08	P06	IO GD30	Y25	IO MD49	AD04	P VCCOQ
A06	I RESET#	D07	O GNT1#	H02	IO AD07	P07	P GND	Y26	IO MD17	AD05	P GNDQ
A07	IO HD56#	D08	I REO3#	H03	IO AD10	P22	P GND	AA01	IO GD13	AD06	IO MD35
A08	IO HD62#	D09	IO HD58#	H04	IO AD12	P23	IO MD62	AA02	IO GD12	AD07	IO MD05
A09	IO HD55#	D10	I REQ4#	H05	IO AD11	P24	IO MD30	AA03	I VCCQ	AD08	IO MD08
A10	IO HD54#	D11	IO HD46#	H06	P GND	P25	IO MD31	AA04	IO GD11	AD09	P GND
A11	IO HD49#	D12	IO HD41#	H21	P GND	P26	P GND	AA05	IO GD09	AD10	IO MD12
A12	IO HD47#	D13	IO HD39#	H22	IO HA04#	R01	IO GD31	AA06	P GND	AD11	IO MD47
A13	IO HD40#	D14	IO HD34#	H23	IO HA06#	R02	IO GD29	AA07	I VCCQ	AD12	IO MECC1
A14	P GND	D15	IO HD35#	H24	IO BNR#	R03	P VCCQ	AA08	P GND	AD13	O DQMA4 / CASA4#
A15	IO HD33#	D16	IO HD30#	H25	IO HTRDY#	R04	IO GD27	AA09	P VCC	AD14	O DQMB1 / CASB1#
A16	IO HD31#	D17	IO HD24#	H26	IO BPRI#	R05	IO GD24	AA10	IO MECC5	AD15	O CSA4# / RASA4#
A17	IO HD27#	D18	IO HD16#	J01	IO AD05	R06	P VCCO	AA11	P VSUS	AD16	O MAB0#
A18	IO HD19#	D19	IO HD15#	J02	IO AD06	R07	P VCCQ	AA12	I SUST#	AD17	O MAB2#
A19	IO HD20#	D20	IO HD14#	J03	P GND	R22	P GND	AA17	O SRASB#	AD18	P GND
A20	IO HD10#	D21	IO HD04#	J04	IO CBE0#	R23	IO MD28	AA18	P VCC	AD19	O MAB5# / strap
A21	IO HD06#	D22	IO HD01#	J05	IO AD09	R24	IO MD60	AA19	P GND	AD20	O MAA10
A22	IO HD03#	D23	IO HA31#	J06	P VCC	R25	IO MD61	AA20	P VCC	AD21	O MAB12# / strap
A23	IO HA29#	D24	IO HA25#	J21	P VCC	R26	IO MD29	AA21	P GND	AD22	P GND
A24	IO HA24#	D25	IO HA18#	J22	IO HREQ0#	T01	IO GD26	AA22	O DQMA2 / CASA2#	AD23	O CKE3 / CSB7#
A25	IO HA22#	D26	IO HA19#	J23	IO HREQ1#	T02	IO GD23	AA23	IO MECC6	AD24	O CSB1# / RASB1#
A26	P GND	E01	IO FRAME#	J24	P GND	T03	IO GBE3#	AA24	O DQMA3 / CASA3#	AD25	I DCLKWR
B01	P VCC	E02	IO IRDY#	J25	IO HREQ4#	T04	IO GD20	AA25	IO MECC2	AD26	O CSB2# / RASB2#
B02	I PCLK	E03	P GND	J26	IO DEFER#	T05	IO GDS1#	AA26	IO MECC7	AE01	IO GD01
B03	IO AD22	E04	IO CBE2#	K01	P GND	T06	IO GDS1	AB01	IO GD08	AE02	I NCOMP
B04	IO AD27	E05	IO AD24	K02	IO AD01	T07	IO MD57	AB02	IO GD10	AE03	O WSC#
B05	IO AD28	E06	IO AD30	K03	IO AD03	T23	IO MD58	AB03	IO GBE0#	AE04	IO MD33
B06	I PREQ#	E07	O GNT0#	K04	IO AD02	T24	IO MD25	AB04	IO GD07	AE05	IO MD01
B07	IO HD50#	E08	O GNT3#	K05	IO AD04	T25	IO MD26	AB05	IO GD00	AE06	IO MD36
B08	IO HD61#	E09	O GNT4#	K06	IO AD00	T26	IO MD59	AB06	IO MD02	AE07	IO MD06
B09	IO HD63#	E10	O GNT2#	K07	P GND	U01	IO GD22	AB07	IO MD37	AE08	IO MD10
B10	IO HD53#	E11	IO HD57#	K21	IO ADS#	U02	IO GD25	AB08	IO MD40	AE09	IO MD43
B11	IO HD48#	E12	P GND	K22	I HLOCK#	U03	IO GD19	AB09	IO MD41	AE10	IO MD13
B12	IO HD42#	E13	IO HD45#	K23	IO DRDY#	U04	IO GD18	AB10	IO MD44	AE11	IO MECC4
B13	IO HD36#	E14	IO HD38#	K24	IO HREQ2#	U05	IO GDS0#	AB11	IO MD14	AE12	O SWEA# / MWEA#
B14	IO HD43#	E15	P GND	K25	IO HREQ3#	U06	P GND	AB12	P GND	AE13	O DQMB5 / CASB5#
B15	IO HD32#	E16	I GTLREF	K26	IO RS0#	U07	P GNDA	AB13	O SCASB#	AE14	O DQMA0 / CASA0#
B16	IO HD29#	E17	IO HD23#	L01	O ST1	U21	IO MD27	AB14	O CSA0# / RASA0#	AE15	O CSA2# / RASA2#
B17	IO HD25#	E18	IO HD13#	L02	I SBA0	U22	IO MD22	AB15	P GND	AE16	O CSA5# / RASA5#
B18	IO HD21#	E19	IO HD11#	L03	O GGNT#	U23	IO MD56	AB16	O MAA1	AE17	O MAA2
B19	IO HD18#	E20	IO HD09#	L04	O ST0	U24	IO MD55	AB17	O MAB3#	AE18	O MAB4#
B20	IO HD12#	E21	IO HD02#	L05	I GREQ#	U25	IO MD23	AB18	O MAB6# / strap	AE19	O MAA5
B21	IO HD08#	E22	IO HA30#	L06	I VCCQ	U26	IO MD24	AB19	O MAB7# / strap	AE20	O MAA9
B22	IO HD00#	E23	IO HA15#	L07	P VCCO	V01	IO GD17	AB20	O MAB10 / strap	AE21	O MAB11# / strap
B23	O CPURST#	E24	P GND	L22	I HITM#	V02	IO GD16	AB21	O DCLKO	AE22	O MAB14#
B24	IO HA27#	E25	IO HA17#	L23	IO DBSY#	V03	IO GD28	AB22	O MAA14/DCLKRD	AE23	P GND
B25	IO HA20#	E26	IO HA16#	L24	IO HIT#	V04	IO GSTOP#	AB23	O CSB5# / RASB5#	AE24	O CKE2 / CSB6#
B26	O BREO0#	F01	IO SERR#	L25	IO RS2#	V05	IO GBE2#	AB24	P GND	AE25	O CSB0# / RASB0#
C01	IO AD19	F02	IO LOCK#	L26	IO RS1#	V06	P VCCA	AB25	P GND	AE26	P VCC
C02	P VCC	F03	IO DEVSEL#	M01	I SBA2	V21	P VCC	AB26	O DQMA7 / CASA7#	AF01	P GND
C03	IO AD21	F04	IO STOP#	M02	I SBA1	V22	IO MD19	AC01	IO GD06	AF02	I PCOMP
C04	IO CBE3#	F05	IO TRDY#	M03	I GPIPE#	V23	IO MD20	AC02	IO GD04	AF03	I PWROK
C05	P GND	F06	P GND	M04	O ST2	V24	P GND	AC03	IO GD05	AF04	IO MD32
C06	IO AD31	F07	P VCC	M05	I SBS#	V25	IO MD21	AC04	P GND	AF05	IO MD34
C07	I REQ1#	F08	P GND	M06	I GWBF#	V26	IO MD54	AC05	IO MD00	AF06	IO MD04
C08	IO HD52#	F09	P VCC	M21	P GNDA	W01	IO GD21	AC06	IO MD03	AF07	IO MD39
C09	P GND	F10	I REQ2#	M22	P GNDA	W02	IO GFRM#	AC07	IO MD38	AF08	IO MD09
C10	IO HD60#	F17	P VTT	M23	I GTLREF	W03	IO GIRDY#	AC08	IO MD07	AF09	IO MD11
C11	IO HD59#	F18	P VCC	M24	P VTT	W04	IO GD15	AC09	IO MD42	AF10	IO MD46
C12	IO HD51#	F19	P GND	M25	I TESTIN#	W05	IO GDSL#	AC10	IO MD45	AF11	IO MECC0
C13	IO HD44#	F20	P VCC	M26	O CPURSTD#	W06	P VCCQ	AC11	IO MD15	AF12	O SCASA#
C14	IO HD37#	F21	P GND	N01	P AGPREF	W21	P GNDA	AC12	O SWEB# / MWEB#	AF13	P GND
C15	IO HD28#	F22	IO HA11#	N02	I SBA3	W22	IO MD18	AC13	O DQMA5 / CASA5#	AF14	P VCC
C16	IO HD26#	F23	IO HA12#	N03	I SBS	W23	IO MD50	AC14	O DQMA1 / CASA1#	AF15	O CSA1# / RASA1#
C17	IO HD22#	F24	IO HA13#	N04	O GCLKO	W24	IO MD51	AC15	O CSA3# / RASA3#	AF16	O SRASA#
C18	P GND	F25	IO HA14#	N05	I GCLK	W25	IO MD53	AC16	O MAB1#	AF17	O MAA0
C19	IO HD17#	F26	IO HA08#	N06	I GRBF#	W26	IO MD52	AC17	O MAA3	AF18	O MAA4
C20	IO HD07#	G01	IO AD13	N07	P GND	Y01	IO GPAR/GCKRUN#	AC18	O MAA7	AF19	O MAA6
C21	IO HD05#	G02	IO AD14	N21	P VCCA	Y02	IO GTRDY#	AC19	O MAA8	AF20	O MAB8# / strap
C22	P GND	G03	IO CBE1#	N22	P VCCA	Y03	P GND	AC20	O MAB9# / strap	AF21	O MAA11
C23	IO HA26#	G04	IO AD15	N23	I HCLK	Y04	IO GBE1#	AC21	O MAA12	AF22	O MAB13#
C24	IO HA28#	G05	IO PAR	N24	P GND	Y05	IO GDS0	AC22	O CKE0 / FENA	AF23	O CKE1 / CSKE
C25	IO HA23#	G06	P VCC	N25	IO MD63	Y06	P GND	AC23	O CKE4 / CSA6#	AF24	O CKE5 / CSA7#
C26	IO HA21#	G21	P VCC	N26	P VCC	Y07	P GND	AC24	O CSB3# / RASB3#	AF25	O MAA13
D01	IO AD16	G22	IO HA10#	P01	I SBA7	Y08	P GND	AC25	O DQMA6 / CASA6#	AF26	P GND

Center VCC Pins (16 pins): L11, L13-14, L16, M12, M15, N11, N16, P11, P16, R12, R15, T11, T13-14, T16
 Center GND Pins (20 pins): L12, L15, M11, M13-14, M16, N12-15, P12-15, R11, R13-14, R16, T12, T15

Figure 4. VT82C694X Pin List (Alphabetical Order)

Pin #	Pin Name	Pin #	Pin Name	Pin #	Pin Name	Pin #	Pin Name	Pin #	Pin Name	Pin #	Pin Name
K06	IO AD00	Y04	IO GBE1#	AA06	P GND	D20	IO HD14#	AB17	O MAB3#	Y22	IO MECC3
K02	IO AD01	Y05	IO GBE2#	AA08	P GND	D19	IO HD15#	AE18	O MAB4#	AE11	IO MECC4
K04	IO AD02	T03	IO GBE3#	AA19	P GND	D18	IO HD16#	AD19	O MAB5# / strap	AA10	IO MECC5
K03	IO AD03	N05	I GCLK	AA21	P GND	C19	IO HD17#	AB18	O MAB6# / strap	AA23	IO MECC6
K05	IO AD04	N04	O GCLKO	AB12	P GND	B19	IO HD18#	AB19	O MAB7# / strap	AA26	IO MECC7
J01	IO AD05	AB05	IO GD00	AB15	P GND	A18	IO HD19#	AF20	O MAB8# / strap	AE02	I NCOMP
J02	IO AD06	AE01	IO GD01	AB24	P GND	A19	IO HD20#	AC20	O MAB9# / strap	G05	IO PAR
H02	IO AD07	AD03	IO GD02	AB25	P GND	B18	IO HD21#	AB20	O MAB10 / strap	B02	I PCLK
H01	IO AD08	AD02	IO GD03	AC04	P GND	C17	IO HD22#	AE21	O MAB11# /	AF02	I PCOMP
J05	IO AD09	AC02	IO GD04	AD09	P GND	E17	IO HD23#	AD21	O MAB12# /	D06	O PGNT#
H03	IO AD10	AC03	IO GD05	AD18	P GND	D17	IO HD24#	AF22	O MAB13#	B06	O PREQ#
H05	IO AD11	AC01	IO GD06	AD22	P GND	B17	IO HD25#	AE22	O MAB14#	AF03	I PWROK
H04	IO AD12	AB04	IO GD07	AE23	P GND	C16	IO HD26#	AC05	IO MD00	A03	I REQ#
G01	IO AD13	AB01	IO GD08	AF01	P GND	A17	IO HD27#	AE05	IO MD01	C07	I REQ#
G02	IO AD14	AA05	IO GD09	AF13	P GND	C15	IO HD28#	AB06	IO MD02	F10	I REQ#
G04	IO AD15	AB02	IO GD10	AF26	P GND	B16	IO HD29#	AC06	IO MD03	D08	I REQ2#
D01	IO AD16	AA04	IO GD11	M21	P GNDA	D16	IO HD30#	AF06	IO MD04	D10	I REQ4#
D03	IO AD17	AA02	IO GD12	M22	P GNDA	A16	IO HD31#	AD07	IO MD05	A06	I RESET#
D02	IO AD18	AA01	IO GD13	U07	P GNDA	B15	IO HD32#	AE07	IO MD06	K26	IO RS0#
C01	IO AD19	AD01	IO GD14	W21	P GNDA	A15	IO HD33#	AC08	IO MD07	L26	IO RS1#
A02	IO AD20	W04	IO GD15	AD05	P GNDOO	D14	IO HD34#	AD08	IO MD08	L25	IO RS2#
C03	IO AD21	V02	IO GD16	E07	O GNT0#	D15	IO HD35#	AF08	IO MD09	L02	I SBA0
B03	IO AD22	V01	IO GD17	D07	O GNT1#	B13	IO HD36#	AE08	IO MD10	M02	I SBA1
D04	IO AD23	U04	IO GD18	E10	O GNT2#	C14	IO HD37#	AF09	IO MD11	M01	I SBA2
E05	IO AD24	U03	IO GD19	E08	O GNT3#	E14	IO HD38#	AD10	IO MD12	N02	I SBA3
A04	IO AD25	T04	IO GD20	E09	O GNT4#	D13	IO HD39#	AE10	IO MD13	P04	I SBA4
D05	IO AD26	W01	IO GD21	Y01	IO GPAR/GCKRUN#	A13	IO HD40#	AB11	IO MD14	P05	I SBA5
B04	IO AD27	U01	IO GD22	M03	I GPIPE#	D12	IO HD41#	AC11	IO MD15	P02	I SBA6
B05	IO AD28	T02	IO GD23	N06	I GRBF#	B12	IO HD42#	Y23	IO MD16	P01	I SBA7
A05	IO AD29	R05	IO GD24	L05	I GREQ#	B14	IO HD43#	Y26	IO MD17	N03	I SBS
E06	IO AD30	U02	IO GD25	V04	IO GSTOP#	C13	IO HD44#	W22	IO MD18	M05	I SBS#
C06	IO AD31	T01	IO GD26	E16	I GTLREF	E13	IO HD45#	V22	IO MD19	AF12	O SCASA#
K21	IO ADS#	R04	IO GD27	M23	I GTLREF	D11	IO HD46#	V23	IO MD20	AB13	O SCASA#
N01	P AGPREF	V03	IO GD28	Y02	IO GTRDY#	A12	IO HD47#	V25	IO MD21	F01	IO SERR#
H24	IO BNR#	R02	IO GD29	M06	I GWBF#	B11	IO HD48#	U22	IO MD22	AF16	O SRASA#
H26	IO BPRI#	P06	IO GD30	G25	IO HA03#	A11	IO HD49#	U25	IO MD23	AA17	O SRASB#
B26	O BREQ0#	R01	IO GD31	H22	IO HA04#	B07	IO HD50#	U26	IO MD24	L04	O ST0
J04	IO CBE0#	Y05	IO GDS0	G23	IO HA05#	C12	IO HD51#	T24	IO MD25	L01	O ST1
G03	IO CBE1#	U05	IO GDS0#	H23	IO HA06#	C08	IO HD52#	T25	IO MD26	M04	O ST2
E04	IO CBE2#	T06	IO GDS1	G24	IO HA07#	B10	IO HD53#	U21	IO MD27	F04	IO STOP#
C04	IO CBE3#	T05	IO GDS1#	F26	IO HA08#	A10	IO HD54#	R23	IO MD28	AA12	IO SUST#
AC22	O CKE0 / FENA	W05	IO GDS1#	G26	IO HA09#	A09	IO HD55#	R26	IO MD29	AE12	O SWEA# / MWEA#
AF23	O CKE1 / GCCKE	W02	IO GFRM#	G22	IO HA10#	A07	IO HD56#	P24	IO MD30	AC12	O SWEB# / MWEB#
AE24	O CKE2 / CSB6#	L03	O GGNT#	F22	IO HA11#	E11	IO HD57#	P25	IO MD31	M25	I TESTIN#
AD23	O CKE3 / CSB7#	W03	IO GIRDY#	F23	IO HA12#	D09	IO HD58#	AF04	IO MD32	F05	IO TRDY#
AC23	O CKE4 / CSA6#	A01	P GND	F24	IO HA13#	C11	IO HD59#	AE04	IO MD33	B01	P VCC
AF24	O CKE5 / CSA7#	A14	P GND	F25	IO HA14#	C10	IO HD60#	AF05	IO MD34	C02	P VCC
B23	O CPURST#	A26	P GND	E23	IO HA15#	B08	IO HD61#	AD06	IO MD35	F07	P VCC
M26	O CPURSTD#	C05	P GND	E26	IO HA16#	A08	IO HD62#	AE06	IO MD36	F09	P VCC
AB14	O CSA0# / RASA0#	C09	P GND	E25	IO HA17#	B09	IO HD63#	AB07	IO MD37	F18	P VCC
AF15	O CSA1# / RASA1#	C18	P GND	D25	IO HA18#	L24	IO HIT#	AC07	IO MD38	F20	P VCC
AE15	O CSA2# / RASA2#	C22	P GND	D26	IO HA19#	L22	I HITM#	AF07	IO MD39	G06	P VCC
AC15	O CSA3# / RASA3#	E03	P GND	B25	IO HA20#	K22	I HLOCK#	AB08	IO MD40	G21	P VCC
AD15	O CSA4# / RASA4#	E12	P GND	C26	IO HA21#	J22	IO HREQ0#	AB09	IO MD41	J06	P VCC
AE16	O CSA5# / RASA5#	E15	P GND	A25	IO HA22#	J23	IO HREQ1#	AC09	IO MD42	J21	P VCC
AE25	O CSB0# / RASB0#	E24	P GND	C25	IO HA23#	K24	IO HREQ2#	AE09	IO MD43	N26	P VCC
AD24	O CSB1# / RASB1#	F06	P GND	A24	IO HA24#	K25	IO HREQ3#	AB10	IO MD44	V21	P VCC
AD26	O CSB2# / RASB2#	F08	P GND	D24	IO HA25#	J25	IO HREQ4#	AC10	IO MD45	AA09	P VCC
AC24	O CSB3# / RASB3#	F19	P GND	C23	IO HA26#	H25	IO HTRDY#	AF10	IO MD46	AA18	P VCC
AC26	O CSB4# / RASB4#	F21	P GND	B24	IO HA27#	E02	IO IRDY#	AD11	IO MD47	AA20	P VCC
AB23	O CSB5# / RASB5#	H06	P GND	C24	IO HA28#	F02	IO LOCK#	Y24	IO MD48	AE26	P VCC
L23	IO DBSY#	H21	P GND	A23	IO HA29#	AF17	O MAA0	Y25	IO MD49	AF14	P VCC
AB21	O DCLKO	J03	P GND	E22	IO HA30#	AB16	O MAA1	W23	IO MD50	N21	P VCCA
AD25	I DCLKWR	J24	P GND	D23	IO HA31#	AE17	O MAA2	W24	IO MD51	N22	P VCCA
J26	IO DEFER#	K01	P GND	N23	I HCLK	AC17	O MAA3	W26	IO MD52	V06	P VCCA
F03	IO DEVSEL#	K07	P GND	B22	IO HD00#	AF18	O MAA4	W25	IO MD53	Y21	P VCCA
AE14	O DQMA0# / CASA0	N07	P GND	D22	IO HD01#	AE19	O MAA5	V26	IO MD54	L06	P VCCO
AC14	O DQMA1# / CASA1	N24	P GND	E21	IO HD02#	AF19	O MAA6	U24	IO MD55	L07	P VCCO
AA22	O DQMA2# / CASA2	P03	P GND	A22	IO HD03#	AC18	O MAA7	U23	IO MD56	R03	P VCCQ
AA24	O DQMA3# / CASA3	P07	P GND	D21	IO HD04#	AC19	O MAA8	T22	IO MD57	R06	P VCCQ
AD13	O DQMA4# / CASA4	P22	P GND	C21	IO HD05#	AE20	O MAA9	T23	IO MD58	R07	P VCCQ
AC13	O DQMA5# / CASA5	P26	P GND	A21	IO HD06#	AD20	O MAA10	T26	IO MD59	W06	P VCCQ
AC25	O DQMA6# / CASA6	R22	P GND	C20	IO HD07#	AF21	O MAA11	R24	IO MD60	AA03	P VCCQ
AB26	O DQMA7# / CASA7	U06	P GND	B21	IO HD08#	AC21	O MAA12	R25	IO MD61	AA07	P VCCQ
AD14	O DQMB1# / CASB1	V24	P GND	E20	IO HD09#	AF25	O MAA13	P23	IO MD62	AD04	P VCCOO
AE13	O DQMB5# / CASB5	Y03	P GND	A20	IO HD10#	AB22	O MAA14/DCLKRD	N25	IO MD63	AA11	P VSUS
K23	IO DRDY#	Y06	P GND	E19	IO HD11#	AD16	O MAB0#	AF11	IO MECC0	M17	P VTT
E01	IO FRAME#	Y07	P GND	B20	IO HD12#	AC16	O MAB1#	AD12	IO MECC1	F24	P VTT
AB03	IO GBE0#	Y08	P GND	E18	IO HD13#	AD17	O MAB2#	AA25	IO MECC2	AE03	O WSC#

Center VCC Pins (16 pins): L11, L13-14, L16, M12, M15, N11, N16, P11, P16, R12, R15, T11, T13-14, T16
Center GND Pins (20 pins): L12, L15, M11, M13-14, M16, N12-15, P12-15, R11, R13-14, R16, T12, T15

PIN DESCRIPTIONS

Table 1. VT82C694X Pin Descriptions

CPU Interface			
Signal Name	Pin #	I/O	Signal Description
HA[31:3]#	(see pinout tables)	IO	Host Address Bus. HA[31:3] connect to the address bus of the host CPU. During CPU cycles HA[31:3] are inputs. These signals are driven by the VT82C694X during cache snooping operations.
HD[63:0]#	(see pinout tables)	IO	Host CPU Data. These signals are connected to the CPU data bus.
ADS#	K21	IO	Address Strobe. The CPU asserts ADS# in T1 of the CPU bus cycle.
BNR#	H24	IO	Block Next Request. Used to block the current request bus owner from issuing new requests. This signal is used to dynamically control the processor bus pipeline depth.
BPRI#	H26	IO	Priority Agent Bus Request. The owner of this signal will always be the next bus owner. This signal has priority over symmetric bus requests and causes the current symmetric owner to stop issuing new transactions unless the HLOCK# signal is asserted. The VT82C694X drives this signal to gain control of the processor bus.
DBSY#	L23	IO	Data Bus Busy. Used by the data bus owner to hold the data bus for transfers requiring more than one cycle.
DEFER#	J26	IO	Defer. The VT82C694X uses a dynamic deferring policy to optimize system performance. The VT82C694X also uses the DEFER# signal to indicate a processor retry response.
DRDY#	K23	IO	Data Ready. Asserted for each cycle that data is transferred.
HIT#	L24	IO	Hit. Indicates that a cacheing agent holds an unmodified version of the requested line. Also driven in conjunction with HITM# by the target to extend the snoop window.
HITM#	L22	I	Hit Modified. Asserted by the CPU to indicate that the address presented with the last assertion of EADS# is modified in the L1 cache and needs to be written back.
HLOCK#	K22	I	Host Lock. All CPU cycles sampled with the assertion of HLOCK# and ADS# until the negation of HLOCK# must be atomic.
HREQ[4:0]#	J25, K25, K24, J23, J22	IO	Request Command. Asserted during both clocks of the request phase. In the first clock, the signals define the transaction type to a level of detail that is sufficient to begin a snoop request. In the second clock, the signals carry additional information to define the complete transaction type.
HTRDY#	H25	IO	Host Target Ready. Indicates that the target of the processor transaction is able to enter the data transfer phase.
RS[2:0]#	L25, L26, K26	IO	Response Signals. Indicates the type of response per the table below: <u>RS[2:0]#</u> <u>Response type</u> 000 Idle State 001 Retry Response 010 Defer Response 011 Reserved 100 Hard Failure 101 Normal Without Data 110 Implicit Writeback 111 Normal With Data
CPURST#	B23	O	CPU Reset. Reset output to CPU
CPURSTD#	M26	O	CPU Reset Delayed. Reset output delayed 2T from CPURST#. Used to enable an external LV244 buffer for fraction / ratio selection.
BREQ0#	B26	O	Bus Request 0. Bus request output to CPU.

Note: Clocking of the CPU interface is performed with HCLK. See the clock pin group at the end of the pin descriptions section for descriptions of the clock pins.

The VT82C694X pinouts were defined assuming the ATX PCB layout model shown below (and general pin layout shown) as a guide for PCB component placement. Other PCB layouts (AT, LPX, and NLX) were also considered and can typically follow the same general component placement.

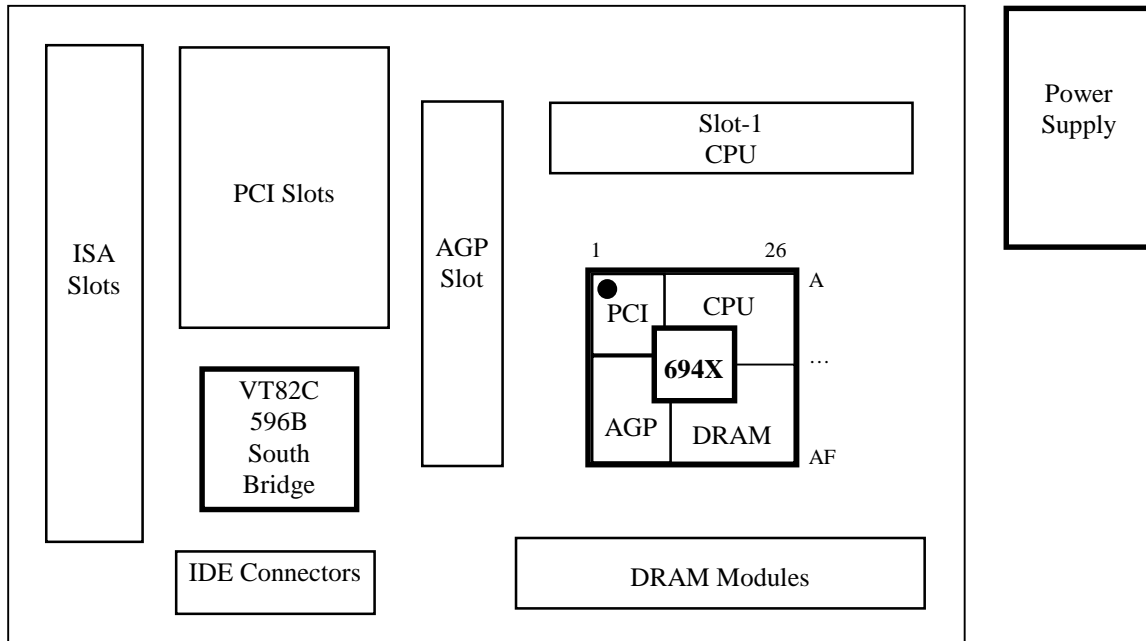

DRAM Interface																														
Signal Name	Pin #	I/O	Signal Description																											
MD[63:0]	(see pinout tables)	IO	Memory Data. These signals are connected to the DRAM data bus. Note: MD0 is internally pulled up for use in EDO memory type detection.																											
MECC[7:0]	AA26, AA23, AA10, AE11, Y22, AA25, AD12, AF11	IO	DRAM ECC or EC Data (see Rx6E)																											
MAA14 / DCLKRD MAA[13:0]	(see pinout tables)	O / I O	Memory Address A. DRAM address lines (two sets for better drive)																											
MAB[14]#, MAB[13]#, MAB[12]# / strap, MAB[11]# / strap, MAB[10] / strap, MAB[9]# / strap, MAB[8]# / strap, MAB[7]# / strap, MAB[6]# / strap, MAB[5]# / strap, MAB[4:0]#	AE22, AF22, AD21, AE21, AB20, AC20, AF20, AB19, AB18, AD19, AE18, AB17, AD17, AC16, AD16	O	Memory Address B. DRAM address lines (two sets for better drive). Note that this set of memory address pins is opposite polarity from the "A" set (except for MAB10 which must be positive polarity because it is used for the SDRAM Precharge command). Selected pins are also used for strap options: <table border="0"> <thead> <tr> <th></th> <th>Bit</th> <th>Internal PU/PD</th> </tr> </thead> <tbody> <tr> <td>MAB12# CPU Bus Frequency Select 0</td> <td>Rx68[0]</td> <td>PD</td> </tr> <tr> <td>MAB11# In-Order Queue Depth Enable</td> <td>Rx50[7]</td> <td>PU</td> </tr> <tr> <td>MAB10 Quick Start Select</td> <td>Rx52[5]</td> <td>PD</td> </tr> <tr> <td>MAB9# AGP Disable</td> <td>RxAC[7]</td> <td>PD</td> </tr> <tr> <td>MAB8# CPU Bus Frequency Select 1</td> <td>Rx68[1]</td> <td>PD</td> </tr> <tr> <td>MAB7# Memory Module Configuration</td> <td>Rx6B[4]</td> <td>PD</td> </tr> <tr> <td>MAB6# GTL I/O Buffer Pullup</td> <td>Rx52[7]</td> <td>PD</td> </tr> <tr> <td>MAB5# PCI 33 / 66 MHz Select</td> <td>Rx7B[0]</td> <td>PD</td> </tr> </tbody> </table>		Bit	Internal PU/PD	MAB12# CPU Bus Frequency Select 0	Rx68[0]	PD	MAB11# In-Order Queue Depth Enable	Rx50[7]	PU	MAB10 Quick Start Select	Rx52[5]	PD	MAB9# AGP Disable	RxAC[7]	PD	MAB8# CPU Bus Frequency Select 1	Rx68[1]	PD	MAB7# Memory Module Configuration	Rx6B[4]	PD	MAB6# GTL I/O Buffer Pullup	Rx52[7]	PD	MAB5# PCI 33 / 66 MHz Select	Rx7B[0]	PD
	Bit	Internal PU/PD																												
MAB12# CPU Bus Frequency Select 0	Rx68[0]	PD																												
MAB11# In-Order Queue Depth Enable	Rx50[7]	PU																												
MAB10 Quick Start Select	Rx52[5]	PD																												
MAB9# AGP Disable	RxAC[7]	PD																												
MAB8# CPU Bus Frequency Select 1	Rx68[1]	PD																												
MAB7# Memory Module Configuration	Rx6B[4]	PD																												
MAB6# GTL I/O Buffer Pullup	Rx52[7]	PD																												
MAB5# PCI 33 / 66 MHz Select	Rx7B[0]	PD																												
CSA[5:0]# / RASA[5:0]#	AE16, AD15, AC15, AE15, AF15, AB14	O	Multifunction Pins (two sets for better drive) 1. Synchronous DRAM: Chip select of each bank.. 2. FPG/EDO DRAM: Row Address Strobe of each bank.																											
CSB[5:0]# / RASB[5:0]#	AB23, AC26, AC24, AD26, AD24, AE25	O	Multifunction Pins (two sets for better drive) 1. Synchronous DRAM: Chip select of each bank.. 2. FPG/EDO DRAM: Row Address Strobe of each bank.																											
DQMA[7:0] / CASA[7:0]#	AB26, AC25, AC13, AD13, AA24, AA22, AC14, AE14	O	Multifunction Pins 1. Synchronous DRAM: Data mask of each byte. 2. FPG/EDO DRAM: Column Address Strobe of each byte lane.																											
DQMB5 / CASB5#, DQMB1 / CASB1#	AE13 AD14	O	Multifunction Pins 1. Synchronous DRAM: Data mask of bytes 5 and 1 2. FPG/EDO DRAM: Column Address Strobe of bytes 5 and 1																											
SRASA#, SRASB#	AF16, AA17	O	Row Address Command Indicator. (two sets for better drive)																											
SCASA#, SCASB#	AF12, AB13	O	Column Address Command Indicator. (two sets for better drive)																											
SWEA# / MWEA#, SWEB# / MWEB#	AE12, AC12	O	Write Enable Command Indicator. (two sets for better drive)																											
CKE0 / FENA, CKE1 / GCKE, CKE2 / CSB6#, CKE3 / CSB7#, CKE4 / CSA6#, CKE5 / CSA7#	AC22, AF23, AE24, AD23, AC23, AF24	O	Clock Enables. Clock enables for each DRAM bank (Rx78[0]=1) for powering down the SDRAMs in notebook applications. Also used in desktop systems for clock control for reducing power usage and for reducing heat/temperature in high-speed memory systems. Alternate functions: FENA = FET Enable, GCKE = Global CKE.																											

PCI Bus Interface			
<u>Signal Name</u>	<u>Pin #</u>	<u>I/O</u>	<u>Signal Description</u>
AD[31:0]	(see pinout tables)	IO	Address/Data Bus. The standard PCI address and data lines. The address is driven with FRAME# assertion and data is driven or received in following cycles.
CBE[3:0]#	C4, E4, G3, J4	IO	Command/Byte Enable. Commands are driven with FRAME# assertion. Byte enables corresponding to supplied or requested data are driven on following clocks.
FRAME#	E1	IO	Frame. Assertion indicates the address phase of a PCI transfer. Negation indicates that one more data transfer is desired by the cycle initiator.
IRDY#	E2	IO	Initiator Ready. Asserted when the initiator is ready for data transfer.
TRDY#	F5	IO	Target Ready. Asserted when the target is ready for data transfer.
STOP#	F4	IO	Stop. Asserted by the target to request the master to stop the current transaction.
DEVSEL#	F3	IO	Device Select. This signal is driven by the VT82C694X when a PCI initiator is attempting to access main memory. It is an input when the VT82C694X is acting as a PCI initiator.
PAR	G5	IO	Parity. A single parity bit is provided over AD[31:0] and C/BE[3:0].
SERR#	F1	IO	System Error. VT82C694X will pulse this signal when it detects a system error condition.
LOCK#	F2	IO	Lock. Used to establish, maintain, and release resource lock.
PREQ#	B6	I	South Bridge Request. This signal comes from the South Bridge. PREQ# is the South Bridge request for the PCI bus.
PGNT#	D6	O	South Bridge Grant. This signal driven by the VT82C694X to grant PCI access to the South Bridge.
REQ[4:0]#	D10, D8, F10, C7, A3	I	PCI Master Request. PCI master requests for PCI.
GNT[4:0]#	E9, E8, E10, D7, E7	O	PCI Master Grant. Permission is given to the master to use PCI.
WSC#	AE3	O	Write Snoop Complete. Sideband PCI signal (used on the planar only in multiprocessor configurations) asserted to indicate that all snoop activity on the CPU bus initiated by the last PCI-to-DRAM write is complete and that it is safe to send an APIC interrupt message. Basically this signal is always active except when PCI master write data is not flushed.

Note: Clocking of the PCI interface is performed with PCLK; see the clock pin group at the end of the pin descriptions section for descriptions of the clock pins.

AGP Bus Interface			
Signal Name	Pin #	I/O	Signal Description
GD[31:0]	(see pinout tables)	IO	Address/Data Bus. The standard AGP/PCI address and data lines. The address is driven with GDS0# and GDS1# assertion for AGP transfers and is driven with GFRM# assertion for PCI transfers.
GDS0	Y5	IO	Bus Strobe 0 (AGP transactions only). Provides timing for 2x data transfer mode on AD[15:0]. The agent that is providing the data drives this signal.
GDS0#	U5	IO	Bus Strobe 0 complement and Bus Strobe 0 (AGP transactions only). Provides timing for 4x data transfer mode on AD[15:0]. The agent that is providing the data drives this signal.
GDS1	T6	IO	Bus Strobe 1 (AGP transactions only). Provides timing for 2x data transfer mode on AD[31:16]. The agent that is providing the data drives this signal.
GDS1#	T5	IO	Bus Strobe 1 complement and Bus Strobe 1 (AGP transactions only). Provides timing for 4x data transfer mode on AD[31:16]. The agent that is providing the data drives this signal.
GBE[3:0]#	T3, V5, Y4, AB3	IO	Command/Byte Enable. AGP: These pins provide command information (different commands than for PCI) driven by the master (graphics controller) when requests are being enqueued using PIPE#. These pins provide valid byte information during AGP write transactions and are driven by the master. The target (this chip) drives these lines to "0000" during the return of AGP read data, but the state of these pins is ignored by the AGP master. PCI: Commands are driven with GFRM# assertion. Byte enables corresponding to supplied or requested data are driven on following clocks.
GFRM#	W2	IO	Frame (PCI transactions only). Assertion indicates the address phase of a PCI transfer. Negation indicates that one more data transfer is desired by the cycle initiator.
GIRDY#	W3	IO	Initiator Ready AGP: For write operations, the assertion of this pin indicates that the master is ready to provide <i>all</i> write data for the current transaction. Once this pin is asserted, the master is not allowed to insert wait states. For read operations, the assertion of this pin indicates that the master is ready to transfer a subsequent block of read data. The master is <i>never</i> allowed to insert a wait state during the initial block of a read transaction. However, it may insert wait states after each block transfers. PCI: Asserted when the initiator is ready for data transfer.
GTRDY#	Y2	IO	Target Ready: AGP: Indicates that the target is ready to provide read data for the entire transaction (when the transaction can complete within four clocks) or is ready to transfer a (initial or subsequent) block of data when the transfer requires more than four clocks to complete. The target is allowed to insert wait states after each block transfers on both read and write transactions. PCI: Asserted when the target is ready for data transfer.
GSTOP#	V4	IO	Stop (PCI transactions only). Asserted by the target to request the master to stop the current transaction.
GDSEL#	W5	IO	Device Select (PCI transactions only). This signal is driven by the VT82C694X when a PCI initiator is attempting to access main memory. It is an input when the VT82C694X is acting as PCI initiator. Not used for AGP cycles.

Note: Clocking of the AGP interface is performed with GCLK; see the clock pin group for descriptions of the clock pins.

Note: PCB Layout Guidelines (reference from AGP specification)

- Total motherboard trace length 10" max, trace impedance = 65 ohms ± 15 ohms, minimize signal crosstalk
- Trace lengths within groups matched to within 2 inches or better
Groups are:
 - GDS0#, GDS0, GD15-0, GBE1-0#
 - GDS1#, GDS1, GD31-16, GBE3-2#
 - SBS#, SBS, SBA7-0
- Ground isolation should be provided around GDS0#, GDS0, GDS1# and GDS1 to prevent crosstalk with GD[31:0]. Ideally ground traces should be provided adjacent to GDSn# on the same signal layer, but at a minimum wider spaces should be provided on either side (e.g., 16 mil spaces on either side of GDSn# if GDSn# signal traces are 8 mil).

AGP Bus Interface (continued)			
Signal Name	Pin #	IO	Signal Description
GPIPE#	M3	I	Pipelined Request. Asserted by the master (graphics controller) to indicate that a full-width request is to be enqueued by the target VT82C694X. The master enqueues one request each rising edge of GCLK while PIPE# is asserted. When PIPE# is deasserted no new requests are enqueued across the AD bus.
GRBF#	N6	I	Read Buffer Full. Indicates if the master (graphics controller) is ready to accept previously requested low priority read data. When RBF# is asserted, the VT82C694X will not return low priority read data to the master.
GWBF#	M6	I	Write Buffer Full.
SBA[7:0]	P1, P2, P5, P4, N2, M1, M2, L2	I	SideBand Address. Provides an additional bus to pass address and command information from the master (graphics controller) to the target (the VT82C694X). These pins are ignored until enabled.
SBS	N3	I	Sideband Strobe. Provides timing for SBA[7:0] (driven by the master)
SBS#	M5	I	Sideband Strobe complement and SBS . Provides timing for SBA[7:0] (driven by the master) when 4x timing is supported.
ST[2:0]	M4, L1, L4	O	Status (AGP only). Provides information from the arbiter to a master to indicate what it may do. Only valid while GGNT# is asserted. 000 Indicates that previously requested low priority read or flush data is being returned to the master (graphics controller). 001 Indicates that previously requested high priority read data is being returned to the master. 010 Indicates that the master is to provide low priority write data for a previously enqueued write command. 011 Indicates that the master is to provide high priority write data for a previously enqueued write command. 100 Reserved. (arbiter must not issue, may be defined in the future). 101 Reserved. (arbiter must not issue, may be defined in the future). 110 Reserved. (arbiter must not issue, may be defined in the future). 111 Indicates that the master (graphics controller) has been given permission to start a bus transaction. The master may enqueue AGP requests by asserting PIPE# or start a PCI transaction by asserting GFRM#. ST[2:0] are always outputs from the VT82C694X and inputs to the master.
GREQ#	L5	I	Request. Master request for AGP.
GGNT#	L3	O	Grant. Permission is given to the master to use AGP.
GPAR / GCKRUN#	Y1	IO IO	Rx78[1]=0: AGP Parity. A single parity bit is provided over GD[31:0] and GBE[3:0]. Rx78[1]=1: AGP Clock Run. Used to stop the AGP bus clock to reduce bus power usage.

Note: For PCI operation on the AGP bus, the following pins are not required:

- PERR# (parity and error reporting not required on transient data devices such as graphics controllers)
- LOCK# (no lock requirement on AGP)
- IDSEL (internally connected to AD16 on AGP-compliant masters)

Note: Separate system interrupts are not provided for AGP. The AGP connector provides interrupts via PCI bus INTA-B#.

Note: The AGP bus supports only one master directly (REQ[3:0]# and GNT[3:0]# are not provided). External logic is required to implement additional master capability. Note that the arbitration mechanism on the AGP bus is different from the PCI bus.

Note: A separate reset is not required for the AGP bus (RESET# resets both PCI and AGP buses)

Note: Two mechanisms are provided by the AGP bus to enqueue master requests: GPIPE# (to send addresses multiplexed on the AD lines) and the SBA port (to send addresses unmultiplexed). AGP masters implement one or the other or select one at initialization time (they are not allowed to change during runtime). Therefore only one of the two will be used and the signals associated with the other will not be used. Therefore the VT82C694X has an internal pullup on GRBF# to maintain it in the de-asserted state in case it is not implemented on the master device.

Clock / Reset Control																												
Signal Name	Pin #	I/O	Signal Description																									
HCLK	N23	I	Host Clock. This pin receives the host CPU clock (66 / 100 / 133 MHz). This clock is used by all VT82C694X logic that is in the host CPU domain. The memory interface logic will also use this clock if selected (memory system timing can alternately be selected to use the AGP bus clock). The CPU clock must lead the AGP clock by 0.2 ± 0.5 nsec.																									
PCLK	B2	I	<p>PCI Clock. This pin receives a buffered host clock divided-by-2, 3, or 4 to create 33 MHz. This clock is used by all of the VT82C694X logic that is in the PCI clock domain. This clock input must be 33 MHz maximum to comply with PCI specification requirements and must be synchronous with the host CPU clock, HCLK, with an HCLK:PCLK frequency ratio of 2:1, 3:1, or 4:1 as shown in the table below. The host CPU clock must lead the PCI clock by 1.5 ± 0.5 nsec.</p> <p><u>Typical Clock Frequency Combinations</u></p> <table border="1"> <thead> <tr> <th>Rx68[1:0]</th> <th>Mode</th> <th>Host Clock</th> <th>AGP Clock</th> <th>PCI Clock</th> </tr> </thead> <tbody> <tr> <td>00</td> <td>2x</td> <td>66 MHz</td> <td>66 MHz</td> <td>33 MHz</td> </tr> <tr> <td>01</td> <td>3x</td> <td>100 MHz</td> <td>66 MHz</td> <td>33 MHz</td> </tr> <tr> <td>10</td> <td>4x</td> <td>133 MHz</td> <td>66 MHz</td> <td>33 MHz</td> </tr> <tr> <td>11</td> <td>Reserved</td> <td></td> <td></td> <td></td> </tr> </tbody> </table>	Rx68[1:0]	Mode	Host Clock	AGP Clock	PCI Clock	00	2x	66 MHz	66 MHz	33 MHz	01	3x	100 MHz	66 MHz	33 MHz	10	4x	133 MHz	66 MHz	33 MHz	11	Reserved			
Rx68[1:0]	Mode	Host Clock	AGP Clock	PCI Clock																								
00	2x	66 MHz	66 MHz	33 MHz																								
01	3x	100 MHz	66 MHz	33 MHz																								
10	4x	133 MHz	66 MHz	33 MHz																								
11	Reserved																											
GCLK	N5	I	AGP Clock. This pin receives the AGP bus clock (66 MHz). This clock is used by all VT82C694X logic that is in the AGP clock domain. The AGP clock must be synchronous / pseudo-synchronous to the host CPU clock (selectable as shown in the table above). The CPU clock must lead the AGP clock by 0.2 ± 0.5 nsec.																									
GCLKO	N4	O	AGP Clock Feedback.																									
DCLKO	AB21	O	DRAM Clock. Output from internal clock generator to the external clock buffer.																									
DCLKWR	AD25	I	DRAM Clock Input. Input from the external clock buffer.																									
DCLKRD / MAA14	AB22	I / O	DRAM Clock Input. No function (used for chip test). MAA14 if Rx69[5]=1.																									
RESET#	A6	I	Reset. Input from south bridge chip. When asserted, this signal resets the VT82C694X and sets all register bits to the default value. The same signal that connects to this pin may also be used (connected through an external inverter) to reset the ISA bus (if implemented). The rising edge of this signal is used to sample all power-up strap options (see HA25-27).																									
PWROK	AF3	I	Power OK.																									
CPURST#	B23	O	CPU Reset. CPU Reset output to the CPU.																									
CPURSTD#	M26	O	CPU Reset Delayed. Reset output delayed 2T from CPURST#. Used to enable an external LV244 buffer for fraction / ratio selection.																									
SUST#	AA12	I	Suspend Status. For implementation of the Suspend-to-DRAM feature. Connect to an external pullup to disable.																									
GCKRUN# / GPAR	Y1	IO / IO	<p>Rx78[1]=1: AGP Clock Run. Used to stop the AGP bus clock to reduce bus power usage.</p> <p>Rx78[1]=0: AGP Parity. A single parity bit is provided over GD[31:0] and GBE[3:0].</p>																									

Power, Ground, and Test			
Signal Name	Pin #	I/O	Signal Description
VCC	(see pin list)	P	Power for Internal Logic (3.3V ±0.3V).
GND	(see pin list)	P	Ground
VSUS	AA11	P	Suspend Power (3.3V ±0.3V).
VCCA	N21, N22, V6, Y21	P	Analog Power (3.3V ±0.3V). For internal clock logic.
GND A	M21, M22, U7, W21	P	Analog Ground. For internal clock logic. Connect to main ground plane.
VCCQ	L6-L7, R3, R6-R7, W6, AA3, AA7	P	AGP 1.5V or 3.3V Power. 1.5V is used for AGP 4x transfer mode. 3.3V is used for AGP 2x mode.
VCCQQ	AD4	P	AGP Quiet Power.
GNDQQ	AD5		AGP Quiet Ground.
VTT	F17, M24	P	CPU Interface Termination Voltage (1.5V ±10%).
GTLREF	E16, M23	P	CPU Interface GTL+ Voltage Reference. 2/3 VTT ±2%
AGPREF	U4	P	AGP Voltage Reference. 0.39 VCCQ to 0.41 VCCQ. Typical value is 0.6V (0.4 times 1.5V) or 1.32V (0.40 times 3.3V). This can be provided with a resistive divider on VCCQ using 270 ohm and 180 ohm (2%) resistors.
NCOMP	AE2	I	Compensation. Connect to VCCQ through a 60 ohm resistor.
PCOMP	AF2	I	Compensation. Connect to GND through a 60 ohm resistor.
TESTIN#	M25	I	Test Input. NAND tree / tristate mode test select.

REGISTERS

Register Overview

The following tables summarize the configuration and I/O registers of the VT82C694X. These tables also document the power-on default value (“Default”) and access type (“Acc”) for each register. Access type definitions used are RW (Read/Write), RO (Read/Only), “—” for reserved / used (essentially the same as RO), and RWC (or just WC) (Read / Write 1’s to Clear individual bits). Registers indicated as RW may have some read-only bits that always read back a fixed value (usually 0 if unused); registers designated as RWC or WC may have some read-only or read write bits (see individual register descriptions following these tables for details). All offset and default values are shown in hexadecimal unless otherwise indicated.

Table 2. VT82C694X Registers

VT82C694X I/O Ports

Port #	I/O Port	Default	Acc
22	PCI / AGP Arbiter Disable	00	RW
CFB-8	Configuration Address	0000 0000	RW
CFE-C	Configuration Data	0000 0000	RW

VT82C694X Device 0 Registers - Host Bridge

Header Registers

Offset	Configuration Space Header	Default	Acc
1-0	Vendor ID	1106	RO
3-2	Device ID	0691	RO
5-4	Command	0006	RW
7-6	Status	0210	WC
8	Revision ID	8n	RO
9	Program Interface	00	RO
A	Sub Class Code	00	RO
B	Base Class Code	06	RO
C	Reserved	00	—
D	Latency Timer	00	RW
E	Header Type	00	RO
F	Built In Self Test (BIST)	00	RO
13-10	Graphics Aperture Base	0000 0008	RW
14-27	Reserved	00	—
28-2B	Reserved	00	—
2D-2C	Subsystem Vendor ID	0000	W1
2F-2E	Subsystem ID	0000	W1
33-30	Reserved	00	—
37-34	Capability Pointer	0000 00A0	RO
3F-38	Reserved	00	—

Device-Specific Registers

Offset	Host CPU Protocol Control	Default	Acc
50	Request Phase Control	00	RW
51	Response Phase Control	00	RW
52	Dynamic Defer Timer	10	RW
53	Miscellaneous 1	03	RW
54	Miscellaneous 2	00	RW
55	Reserved	00	—

Offset	DRAM Control	Default	Acc
59-58	MA Map Type	0040	RW
5F-5A	DRAM Row Ending Address:		
5A	Bank 0 Ending (HA[31:24])	01	RW
5B	Bank 1 Ending (HA[31:24])	01	RW
5C	Bank 2 Ending (HA[31:24])	01	RW
5D	Bank 3 Ending (HA[31:24])	01	RW
5E	Bank 4 Ending (HA[31:24])	01	RW
5F	Bank 5 Ending (HA[31:24])	01	RW
56	Bank 6 Ending (HA[31:24])	01	RW
57	Bank 7 Ending (HA[31:24])	01	RW
60	DRAM Type	00	RW
61	ROM Shadow Control C0000-CFFFF	00	RW
62	ROM Shadow Control D0000-DFFFF	00	RW
63	ROM Shadow Control E0000-FFFFF	00	RW
64	DRAM Timing for Banks 0,1	EC	RW
65	DRAM Timing for Banks 2,3	EC	RW
66	DRAM Timing for Banks 4,5	EC	RW
67	DRAM Timing for Banks 6,7	EC	RW
68	DRAM Control	00	RW
69	DRAM Clock Select	00	RW
6A	DRAM Refresh Counter	00	RW
6B	DRAM Arbitration Control	01	RW
6C	SDRAM Control	00	RW
6D	DRAM Control Drive Strength	00	RW
6E	ECC Control	00	RW
6F	ECC Status	00	RO

Device-Specific Registers (continued)

Offset	PCI Bus Control	Default	Acc
70	PCI Buffer Control	00	RW
71	CPU to PCI Flow Control 1	00	RW
72	CPU to PCI Flow Control 2	00	RW
73	PCI Master Control 1	00	RW
74	PCI Master Control 2	00	RW
75	PCI Arbitration 1	00	RW
76	PCI Arbitration 2	00	RW
77	Chip Test (do not program)	00	RW
78	PMU Control	00	RW
79	PMU Control	00	RW
7A	Miscellaneous Control 1	00	RW
7B	Miscellaneous Control 2	02	RW
7C-7D	Reserved	00	—
7E-7F	PLL Test Mode (do not program)	00	RW

Offset	GART/TLB Control	Default	Acc
83-80	GART/TLB Control	0000 0000	RW
84	Graphics Aperture Size	00	RW
85-87	Reserved (unassigned)	00	—
8B-88	Gr. Aperture TLB Base Register Base	0000 0000	RW
9F-8C	Reserved (unassigned)	00	—

Offset	AGP Control	Default	Acc
A0	AGP ID	02	RO
A1	AGP Next Item Pointer	00	RO
A2	AGP Specification Revision	20	RO
A3	Reserved (unassigned)	00	—
A7-A4	AGP Status	1F00 0203	RO
AB-A8	AGP Command	0000 0000	RW
AC	AGP Control	08	RW
AD	AGP Latency Timer	02	RW
AE	AGP Miscellaneous Control	00	RW
AF	Reserved	00	—
B0	AGP Compensation Control / Status	8x	RW
B1	AGP Drive Strength	63	RW
B2-BF	Reserved	00	—

Offset	Miscellaneous Control	Default	Acc
C0-DF	Reserved	00	—
E0	Miscellaneous Control	00	RW
E1-EF	Reserved	00	—
F7-F0	BIOS Scratch Registers	00	RW
F8	DRAM Arbitration Timer	00	RW
F9	VGA Timer	00	RW
FB-FA	Reserved	0000	RW
FC	Back-Door Control 1	00	RW
FD	Back-Door Control 2	00	RW
FF-FE	Back-Door Device ID	0000	RW

VT82C694X Device 1 - PCI-to-PCI Bridge

Header Registers

Offset	Configuration Space Header	Default	Acc
1-0	Vendor ID	1106	RO
3-2	Device ID	8598	RO
5-4	Command	0007	RW
7-6	Status	0220	WC
8	Revision ID	nn	RO
9	Program Interface	00	RO
A	Sub Class Code	04	RO
B	Base Class Code	06	RO
C	Reserved	00	—
D	Latency Timer	00	RW
E	Header Type	01	RO
F	Built In Self Test (BIST)	00	RO
17-10	Reserved	00	—
18	Primary Bus Number	00	RW
19	Secondary Bus Number	00	RW
1A	Subordinate Bus Number	00	RW
1B	Secondary Latency Timer	00	RO
1C	I/O Base	F0	RW
1D	I/O Limit	00	RW
1F-1E	Secondary Status	0000	RO
21-20	Memory Base	FFF0	RW
23-22	Memory Limit (Inclusive)	0000	RW
25-24	Prefetchable Memory Base	FFF0	RW
27-26	Prefetchable Memory Limit	0000	RW
3D-28	Reserved (unassigned)	00	—
3F-3E	PCI-to-PCI Bridge Control	00	RW

Device-Specific Registers

Offset	AGP Bus Control	Default	Acc
40	CPU-to-AGP Flow Control 1	00	RW
41	CPU-to-AGP Flow Control 2	00	RW
42	AGP Master Control	00	RW
43	AGP Master Latency Timer	00	RW
44	Back-Door Register Control	00	RW
45	Fast Write Control	72	RW
47-46	PCI-to-PCI Bridge Device ID	0000	RW
48-7F	Reserved	00	—
80	Capability ID	01	RO
81	Next Pointer	00	RO
82	Power Management Capabilities 1	02	RO
83	Power Management Capabilities 2	00	RO
84	Power Management Control / Status	00	RW
85	Power Management Status	00	RO
86	PCI-PCI Bridge Support Extensions	00	RO
87	Power Management Data	00	RO
88-FF	Reserved	00	—

Miscellaneous I/O

One I/O port is defined in the VT82C694X: Port 22.

Port 22 – PCI / AGP Arbiter DisableRW

- 7-2 Reserved** always reads 0
- 1 AGP Arbiter Disable**
 - 0 Respond to GREQ# signaldefault
 - 1 Do not respond to GREQ# signal
- 0 PCI Arbiter Disable**
 - 0 Respond to all REQ# signals.....default
 - 1 Do not respond to any REQ# signals, including PREQ#

This port can be enabled for read/write access by setting bit-7 of Device 0 Configuration Register 78.

Configuration Space I/O

All registers in the VT82C694X (listed above) are addressed via the following configuration mechanism:

Mechanism #1

These ports respond only to double-word accesses. Byte or word accesses will be passed on unchanged.

Port CFB-CF8 - Configuration Address..... RW

- 31 Configuration Space Enable**
 - 0 Disabled..... default
 - 1 Convert configuration data port writes to configuration cycles on the PCI bus

30-24 Reservedalways reads 0

23-16 PCI Bus Number

Used to choose a specific PCI bus in the system

15-11 Device Number

Used to choose a specific device in the system (devices 0 and 1 are defined for the VT82C694X)

10-8 Function Number

Used to choose a specific function if the selected device supports multiple functions (only function 0 is defined for the VT82C694X).

7-2 Register Number (also called the "Offset")

Used to select a specific DWORD in the VT82C694X configuration space

1-0 Fixedalways reads 0

Port CFF-CFC - Configuration Data..... RW

Refer to PCI Bus Specification Version 2.1 for further details on operation of the above configuration registers.

Register Descriptions

Device 0 Header Registers - Host Bridge

All registers are located in PCI configuration space. They should be programmed using PCI configuration mechanism 1 through CF8 / CFC with bus number, function number, and device number equal to zero.

Device 0 Offset 1-0 - Vendor ID (1106h).....RO

15-0 ID Code (reads 1106h to identify VIA Technologies)

Device 0 Offset 3-2 - Device ID (0691h).....RO

15-0 ID Code (reads 0691h to identify the VT82C694X)

Device 0 Offset 5-4 –Command (0006h).....RW

- 15-10 Reserved** always reads 0
- 9 Fast Back-to-Back Cycle Enable** RO
 - 0 Fast back-to-back transactions only allowed to the same agentdefault
 - 1 Fast back-to-back transactions allowed to different agents
- 8 SERR# Enable**..... RO
 - 0 SERR# driver disableddefault
 - 1 SERR# driver enabled
 (SERR# is used to report parity errors if bit-6 is set).
- 7 Address / Data Stepping** RO
 - 0 Device never does steppingdefault
 - 1 Device always does stepping
- 6 Parity Error Response**.....RW
 - 0 Ignore parity errors & continuedefault
 - 1 Take normal action on detected parity errors
- 5 VGA Palette Snoop** RO
 - 0 Treat palette accesses normallydefault
 - 1 Don't respond to palette accesses on PCI bus
- 4 Memory Write and Invalidate Command**..... RO
 - 0 Bus masters must use Mem Writedefault
 - 1 Bus masters may generate Mem Write & Inval
- 3 Special Cycle Monitoring** RO
 - 0 Does not monitor special cyclesdefault
 - 1 Monitors special cycles
- 2 Bus Master** RO
 - 0 Never behaves as a bus master
 - 1 Can behave as a bus masterdefault
- 1 Memory Space**..... RO
 - 0 Does not respond to memory space
 - 1 Responds to memory spacedefault
- 0 I/O Space** RO
 - 0 Does not respond to I/O spacedefault
 - 1 Responds to I/O space

Device 0 Offset 7-6 – Status (0210h)..... RWC

- 15 Detected Parity Error**
 - 0 No parity error detected default
 - 1 Error detected in either address or data phase. This bit is set even if error response is disabled (command register bit-6).write one to clear
- 14 Signaled System Error (SERR# Asserted)** always reads 0
- 13 Signaled Master Abort**
 - 0 No abort received default
 - 1 Transaction aborted by the master write one to clear
- 12 Received Target Abort**
 - 0 No abort received default
 - 1 Transaction aborted by the target..... write one to clear
- 11 Signaled Target Abort**..... always reads 0
 - 0 Target Abort never signaled
- 10-9 DEVSEL# Timing**
 - 00 Fast
 - 01 Medium..... always reads 01
 - 10 Slow
 - 11 Reserved
- 8 Data Parity Error Detected**
 - 0 No data parity error detected default
 - 1 Error detected in data phase. Set only if error response enabled via command bit-6 = 1 and VT82C694X was initiator of the operation in which the error occurred.write one to clear
- 7 Fast Back-to-Back Capable** always reads 0
- 6 User Definable Features**..... always reads 0
- 5 66MHz Capable**..... always reads 0
- 4 Supports New Capability list** always reads 1
- 3-0 Reserved** always reads 0

Device 0 Offset 8 - Revision ID (8nh)..... RO

7-0 Chip Revision Code ..always reads 8nh (n = rev code)

Device 0 Offset 9 - Programming Interface (00h) RO

7-0 Interface Identifier always reads 00

Device 0 Offset A - Sub Class Code (00h)..... RO

7-0 Sub Class Codereads 00 to indicate Host Bridge

Device 0 Offset B - Base Class Code (06h)..... RO

7-0 Base Class Code ..reads 06 to indicate Bridge Device

Device 0 Offset D - Latency Timer (00h) RW

Specifies the latency timer value in PCI bus clocks.

- 7-3 Guaranteed Time Slice for CPU**..... default=0
- 2-0 Reserved** (fixed granularity of 8 clks) .. always read 0
Bits 2-1 are writeable but read 0 for PCI specification compatibility. The programmed value may be read back in Offset 75 bits 5-4 (PCI Arbitration 1).

Device 0 Host Bridge Header Registers (continued)

Device 0 Offset E - Header Type (00h).....RO

7-0 Header Type Codereads 00: single function

Device 0 Offset F - Built In Self Test (BIST) (00h).....RO

7 BIST Supportedreads 0: no supported functions

6-0 Reserved always reads 0

Device 0 Offset 13-10 - Graphics Aperture Base (00000008h)RW

31-28 Upper Programmable Base Address Bits..... def=0

27-20 Lower Programmable Base Address Bits def=0

These bits behave as if hardwired to 0 if the corresponding Graphics Aperture Size register bit (Device 0 Offset 84h) is 0.

27	26	25	24	23	22	21	20	(This Register)
<u>7</u>	<u>6</u>	<u>5</u>	<u>4</u>	<u>3</u>	<u>2</u>	<u>1</u>	<u>0</u>	(Gr Aper Size)
RW	RW	RW	RW	RW	RW	RW	RW	1M
RW	RW	RW	RW	RW	RW	RW	0	2M
RW	RW	RW	RW	RW	RW	0	0	4M
RW	RW	RW	RW	RW	0	0	0	8M
RW	RW	RW	RW	0	0	0	0	16M
RW	RW	RW	0	0	0	0	0	32M
RW	RW	0	0	0	0	0	0	64M
RW	0	0	0	0	0	0	0	128M
0	0	0	0	0	0	0	0	256M

19-0 Reserved always reads 00008

Note: The locations in the address range defined by this register are prefetchable.

Device 0 Offset 2D-2C – Subsystem Vendor ID (0000h)R/W1

15-0 Subsystem Vendor ID..... default = 0

This register may be written once and is then read only.

Device 0 Offset 2F-2E – Subsystem ID (0000h)..... R/W1

15-0 Subsystem ID default = 0

This register may be written once and is then read only.

Device 0 Offset 37-34 - Capability Pointer (00000A0h) RO

Contains an offset from the start of configuration space.

31-0 AGP Capability List Pointer always reads A0h

Device 0 Configuration Registers - Host Bridge

These registers are normally programmed once at system initialization time.

Host CPU Control

Device 0 Offset 50 – Request Phase Control (00h)RW

- 7 CPU Hardwired IOQ (In Order Queue) Size**
Default per strap on pin MAB11#During reset. This register can be written 0 to restrict the chip to one level of IOQ.
0 1-Level
1 4-Level
- 6 Read-Around-Write**
0 Disabledefault
1 Enable
- 5 Reserved** always reads 0
- 4 Defer Retry When HLOCK Active**
0 Disabledefault
1 Enable
Note: always set this bit to 1
- 3-1 Reserved** always reads 0
- 0 CPU / PCI Master Read DRAM Timing**
0 Start DRAM read after snoop complete def
1 Start DRAM read before snoop complete

Device 0 Offset 51 – Response Phase Control (00h)..... RW

- 7 CPU Read DRAM 0ws for Back-to-Back Read Transactions**
0 Disable..... default
1 Enable
Setting this bit enables maximum read performance by allowing continuous 0 wait state reads for pipelined line reads. If this bit is not set, there will be at least 1T idle time between read transactions.
- 6 CPU Write DRAM 0ws for Back-to-Back Write Transactions**
0 Disable..... default
1 Enable
Setting this bit enables maximum write performance by allowing continuous 0 wait state writes for pipelined line writes and sustained 3T single writes. If this bit is not set, there will be at least 1T idle time between write transactions.
- 5 Reserved**always reads 0
- 4 Fast Response (HIT/HITM sample 1T earlier)**
0 Disable..... default
1 Enable
- 3 Non-Posted IOW**
0 Disable..... default
1 Enable
- 2 CPU Read DRAM Prefetch Buffer Depth**
0 1-level prefetch buffer default
1 4-level prefetch buffer
- 1 CPU-to-DRAM Post-Write Buffer Depth**
0 1-level post-write buffer default
1 4-level post-write buffer
- 0 Concurrent PCI Master / Host Operation**
0 Disable – the CPU bus will be occupied (BPRI asserted) during the entire PCI operation..... def
1 Enable – the CPU bus is only requested before ADS# assertion

Device 0 Offset 52 – Dynamic Defer Timer (10h).....RW

- 7 GTL I/O Buffer Pullup** default = MAB6# Strap
 - 0 Disable
 - 1 Enable
 The default value of this bit is determined by a strap on the MAB6# pin during reset.
- 6 RAW Write Retire Policy (After 2 Writes)**
 - 0 Disabledefault
 - 1 Enable
- 5 Quick Start Select** default = MAB10 Strap
 - 0 Disabledefault
 - 1 Enable
 The default value of this bit is determined by a strap on the MAB10 pin during reset.
- 4-0 Snoop Stall Count**
 - 00 Disable dynamic defer
 - 01-1F Snoop stall count default = 10h

Device 0 Offset 53 – Miscellaneous 1 (03h)..... RW

- 7 HREQ**
 - 0 Disable..... default
 - 1 Enable
- 6 SDRAM Frequency Higher Than CPU Front Side Bus Frequency**
 - 0 Disable..... default
 - 1 Enable
 Setting this bit enables the DRAM subsystem to run at a higher frequency than the CPU FSB frequency. When setting this bit, register bit Rx69[6] must also be set and only SDRAM type DIMM modules may be used. An EDO/SDRAM mix in the DRAM subsystem is not supported in this case.
- 5 PCI/AGP Master-to-CPU / CPU-to-PCI/AGP Slave Concurrency**
 - 0 Disable..... default
 - 1 Enable
- 4 HPRI Function**
 - 0 Disable..... default
 - 1 Enable
- 3 P6Lock Function**
 - 0 Disable..... default
 - 1 Enable
- 2 Line Write / Write Back Without Implicit Write Back Data**
 - 0 Disable..... default
 - 1 Enable
- 1 PCI Master Pipeline Access**
 - 0 Disable
 - 1 Enable default
- 0 Initialization of Fast Write Address Selection**
 - 0 Tail
 - 1 Head default

Device 0 Offset 54 – Miscellaneous 2 (00h)..... RW

- 7-6 Reserved (Do Not Program)** default = 0
- 5-2 Reserved** always reads 0
- 1 Invalidate CPU Internal Cache on PCI Master Access**
 - 0 Disable..... default
 - 1 Enable
- 0 1-1-1-1 PMRDY for PCI Master Access**
 - 0 Disable..... default
 - 1 Enable

DRAM Control

These registers are normally set at system initialization time and not accessed after that during normal system operation. Some of these registers, however, may need to be programmed using specific sequences during power-up initialization to properly detect the type and size of installed memory (refer to the VIA Technologies VT82C694X BIOS porting guide for details).

Table 3. System Memory Map

Space	Start	Size	Address Range	Comment
DOS	0	640K	00000000-0009FFFF	Cacheable
VGA	640K	128K	000A0000-000BFFFF	Used for SMM
BIOS	768K	16K	000C0000-000C3FFF	Shadow Ctrl 1
BIOS	784K	16K	000C4000-000C7FFF	Shadow Ctrl 1
BIOS	800K	16K	000C8000-000CBFFF	Shadow Ctrl 1
BIOS	816K	16K	000CC000-000CFFFF	Shadow Ctrl 1
BIOS	832K	16K	000D0000-000D3FFF	Shadow Ctrl 2
BIOS	848K	16K	000D4000-000D7FFF	Shadow Ctrl 2
BIOS	864K	16K	000D8000-000DBFFF	Shadow Ctrl 2
BIOS	880K	16K	000DC000-000DFFFF	Shadow Ctrl 2
BIOS	896K	64K	000E0000-000EFFFF	Shadow Ctrl 3
BIOS	960K	64K	000F0000-000FFFFF	Shadow Ctrl 3
Sys	1MB	—	00100000-DRAM Top	Can have hole
Bus	D Top		DRAM Top-FFFEFFFF	
Init	4G-64K	64K	FFFEFFFF-FFFFFFF	000Fxxxx alias

Device 0 Offset 59-58 - DRAM MA Map Type (0040h).RW

- 15-13 Bank 5/4 MA Map Type (see below)**
- 12 Reserved** (Bank 5/4 Virtual Channel Enable) ... def=0
- 11-9 Bank 7/6 MA Map Type (see below)**
- 8 Reserved** (Bank 7/6 Virtual Channel Enable) ... def=0
- 7-5 Bank 1/0 MA Map Type**
 - 000 8-bit Column Address
 - 001 9-bit Column Address
 - 010 10-bit Column Addressdefault
 - 011 11-bit Column Address
 - 100 12-bit Column Address (64Mb)
 - 101 Reserved
 - 11x Reserved
- Bank 0/1 MA Map Type (SDRAM)**
 - 000 16Mbit SDRAM.....default
 - 100 64Mbit SDRAM
 - 101 Reserved
 - 11x Reserved
- 4 Reserved** (Bank 1/0 Virtual Channel Enable) ... def=0
- 3-1 Bank 3/2 MA Map Type (see above)**
- 0 Reserved** (Bank 3/2 Virtual Channel Enable) ... def=0

Device 0 Offset 5F-5A – DRAM Row Ending Address:

- Offset 5A – Bank 0 Ending (HA[31:24]) (01h)..... RW**
- Offset 5B – Bank 1 Ending (HA[31:24]) (01h)..... RW**
- Offset 5C – Bank 2 Ending (HA[31:24]) (01h)..... RW**
- Offset 5D – Bank 3 Ending (HA[31:24]) (01h)..... RW**
- Offset 5E – Bank 4 Ending (HA[31:24]) (01h)..... RW**
- Offset 5F – Bank 5 Ending (HA[31:24]) (01h)..... RW**
- Offset 56 – Bank 6 Ending (HA[31:24]) (01h)..... RW**
- Offset 57 – Bank 7 Ending (HA[31:24]) (01h)..... RW**

Note : BIOS is required to fill the ending address registers for all banks even if no memory is populated. The endings have to be in incremental order.

Device 0 Offset 60 – DRAM Type (00h)..... RW

- 7-6 DRAM Type for Bank 7/6**
 - 00 Fast Page Mode DRAM (FPG)..... default
 - 01 EDO DRAM (EDO)
 - 10 Reserved
 - 11 SDRAM
- 5-4 DRAM Type for Bank 5/4.....default=FPG**
- 3-2 DRAM Type for Bank 3/2.....default=FPG**
- 1-0 DRAM Type for Bank 1/0.....default=FPG**

Table 4. Memory Address Mapping Table

EDO/FP DRAM

MA:	13	12	11	10	9	8	7	6	5	4	3	2	1	0	
8-bit Col (000)		23	22	21	11	20	19	18	17	16	15	14	13	12	Row Bits Col Bits
9-bit Col (001)		24	23	22	21	20	19	18	17	16	15	14	13	12	Row Bits Col Bits
10-bit Col (010)		25	24	23	21	20	19	18	17	16	15	14	13	12	Row Bits Col Bits
11-bit Col (011)		26	25	23	21	20	19	18	17	16	15	14	13	12	Row Bits Col Bits
12-bit Col (100)		27	25	23	21	20	19	18	17	16	15	14	13	12	Row Bits Col Bits

SDRAM

MA:	14	13	12	11	10	9	8	7	6	5	4	3	2	1	0	
16Mb (0xx)				11	22	21	20	19	18	17	16	15	14	13	12	Row Bits Col Bits
64Mb (100)	25/26/27	24	13	12	22	21	20	19	18	17	16	15	14	11	23	x4: 10 col x8: 9 col x16: 8 col x32: 8 col
2/4 bank x4, x8, x16; 4-bank x32		24	13	12	PC	26	25	10	9	8	7	6	5	4	3	

"PC" = "Precharge Control" (refer to SDRAM specifications)

16Mb 11x10, 11x9, and 11x8 configurations supported

64Mb x4: 12x10 4bank, 13x10 2bank
x8: 12x9 4bank, 13x9 2bank
x16: 12x8 4bank, 13x8 2bank
x32: 11x8 4bank

Device 0 Offset 61 - Shadow RAM Control 1 (00h)RW

- 7-6 CC000h-CFFFFh**
 - 00 Read/write disabledefault
 - 01 Write enable
 - 10 Read enable
 - 11 Read/write enable
- 5-4 C8000h-CBFFFh**
 - 00 Read/write disabledefault
 - 01 Write enable
 - 10 Read enable
 - 11 Read/write enable
- 3-2 C4000h-C7FFFh**
 - 00 Read/write disabledefault
 - 01 Write enable
 - 10 Read enable
 - 11 Read/write enable
- 1-0 C0000h-C3FFFh**
 - 00 Read/write disabledefault
 - 01 Write enable
 - 10 Read enable
 - 11 Read/write enable

Device 0 Offset 62 - Shadow RAM Control 2 (00h)RW

- 7-6 DC000h-DFFFFh**
 - 00 Read/write disabledefault
 - 01 Write enable
 - 10 Read enable
 - 11 Read/write enable
- 5-4 D8000h-DBFFFh**
 - 00 Read/write disabledefault
 - 01 Write enable
 - 10 Read enable
 - 11 Read/write enable
- 3-2 D4000h-D7FFFh**
 - 00 Read/write disabledefault
 - 01 Write enable
 - 10 Read enable
 - 11 Read/write enable
- 1-0 D0000h-D3FFFh**
 - 00 Read/write disabledefault
 - 01 Write enable
 - 10 Read enable
 - 11 Read/write enable

Device 0 Offset 63 - Shadow RAM Control 3 (00h)..... RW

- 7-6 E0000h-EFFFFh**
 - 00 Read/write disable default
 - 01 Write enable
 - 10 Read enable
 - 11 Read/write enable
- 5-4 F0000h-FFFFFh**
 - 00 Read/write disable default
 - 01 Write enable
 - 10 Read enable
 - 11 Read/write enable
- 3-2 Memory Hole**
 - 00 None default
 - 01 512K-640K
 - 10 15M-16M (1M)
 - 11 14M-16M (2M)
- 1-0 SMI Mapping Control**

	<u>SMM</u>		<u>Non-SMM</u>	
	<u>Code</u>	<u>Data</u>	<u>Code</u>	<u>Data</u>
00	DRAM	DRAM	PCI	PCI
01	DRAM	DRAM	DRAM	DRAM
10	DRAM	PCI	PCI	PCI
11	DRAM	DRAM	DRAM	DRAM

Device 0 Offset 64 - DRAM Timing for Banks 0,1 (ECh)RW

Device 0 Offset 65 - DRAM Timing for Banks 2,3 (ECh)RW

Device 0 Offset 66 - DRAM Timing for Banks 4,5 (ECh)RW

Device 0 Offset 67 - DRAM Timing for Banks 6,7 (ECh)RW

FPG / EDO Settings for Registers 67-64

- 7 RAS Precharge Time**
 0 3T
 1 4Tdefault
- 6 RAS Pulse Width**
 0 4T
 1 5Tdefault
- 5-4 CAS Read Pulse Width**
 00 1T
 01 2T
 10 3Tdefault
 11 4T
- Note: EDO will not automatically reduce the CAS pulse width. For EDO type DRAMs, use 00 if CAS width = 1 is to be used.
- 3 CAS Write Pulse Width**
 0 1T
 1 2Tdefault
- 2 MA-to-CAS Delay**
 0 1T
 1 2Tdefault
- 1 RAS to MA Delay**
 0 1Tdefault
 1 2T
- 0 Reserved** always reads 0

SDRAM Settings for Registers 67-64

- 7 Precharge Command to Active Command Period**
 0 TRP = 2T
 1 TRP = 3T default
- 6 Active Command to Precharge Command Period**
 0 TRAS = 5T
 1 TRAS = 6T default
- 5-4 CAS Latency**
 00 1T
 01 2T
 10 3T default
 11 reserved
- 3 DIMM Type**
 0 Standard
 1 Registered default
- 2 ACTIVE Command to CMD Command Period**
 0 2T
 1 3T default
- 1-0 Bank Interleave**
 00 No Interleave default
 01 2-way
 10 4-way
 11 Reserved

Device 0 Offset 68 - DRAM Control (00h)RW

- 7 SDRAM Open Page Control**
 - 0 Always precharge SDRAM banks when accessing EDO/FPG DRAMs.....default
 - 1 SDRAM banks remain active when accessing EDO/FPG banks
- 6 Bank Page Control**
 - 0 Allow only pages of the same bank active.. def.
 - 1 Allow pages of different banks to be active
- 5 Reserved** always reads 0
- 4 DRAM Data Latch Delay for EDO/FPG DRAM**
 - 0 Latch DRAM data at CCLK rising edge def.
 - 1 Delay latch of DRAM data by ½ CCLK
- 3 EDO Test Mode**
 - 0 Disabledefault
 - 1 Enable
- 2 Burst Refresh**
 - 0 Disabledefault
 - 1 Enable (burst 4 times)
- 1 System Frequency Divider** RO
This bit is latched from MAB8# at the rising edge of RESET# (see table below).
- 0 System Frequency Divider** RO
This bit is latched from MAB12# at the rising edge of RESET#.
 - 00 CPU Frequency = 66 MHz
 - 01 CPU Frequency = 100 MHz
 - 1x CPU Frequency = 133 MHz

Note: See also Rx69[7-6]

Note: MD0 is internally pulled up for EDO detection.

Device 0 Offset 69 – DRAM Clock Select (00h) RW

- 7 CPU Operating Frequency Faster Than DRAM**
 - 0 CPU Same As or Equal to DRAM..... default
 - 1 CPU Faster Than DRAM by 33 MHz
- 6 DRAM Operating Frequency Faster Than CPU**
 - 0 DRAM Same As or Equal to CPU..... default
 - 1 DRAM Faster Than CPU by 33 MHz

<u>Rx68[1-0]</u>	<u>Rx69[7-6]</u>	<u>CPU / DRAM</u>
00	00	66 / 66 (def)
00	01	66 / 100†
01	10	100 / 66
01	00	100 / 100
01	01	100 / 133†
1x	10	133 / 100
1x	00	133 / 133

†Rx53[6] must also be set to 1 for DRAM > CPU

- 5 256Mbit DRAM Support**
 - 0 Disable (pin AB22 is DCLKRD)..... default
 - 1 Enable (pin AB22 is MAA14)
- 4 DRAM Controller Command Register Output**
 - 0 Disable..... default
 - 1 Enable
- 3 Fast DRAM Precharge for Different Bank**
 - 0 Disable..... default
 - 1 Enable
- 2 DRAM 4K Page Enable (for 64Mbit DRAM)**
 - 0 Disable..... default
 - 1 Enable
- 1 DIMM Type**
 - 0 Unbuffered..... default
 - 1 Registered
- 0 Reserved** always reads 0

Device 0 Offset 6A - Refresh Counter (00h).....RW

- 7-0 Refresh Counter** (in units of 16 CPUCLKs)
 - 00 DRAM Refresh Disableddefault
 - 01 32 CPUCLKs
 - 02 48 CPUCLKs
 - 03 64 CPUCLKs
 - 04 80 CPUCLKs
 - 05 96 CPUCLKs
 -

The programmed value is the desired number of 16-CPUCLK units minus one.

Device 0 Offset 6B - DRAM Arbitration Control (01h) RW

- 7-6 Arbitration Parking Policy**
 - 00 Park at last bus owner default
 - 01 Park at CPU side
 - 10 Park at AGP side
 - 11 Reserved
- 5 Fast Read to Write turn-around**
 - 0 Disable default
 - 1 Enable
- 4 Memory Module ConfigurationRO**
 - 0 Normal Operation default
 - 1 Unused Outputs Tristated (CSB#, DQMB, CKE, MAB, DCLKO)

This bit is latched from MAB7# at the rising edge of RESET#.
- 3 MD Bus Second Level Strength Control**
 - 0 Normal slew rate control..... default
 - 1 More slew rate control
- 2 CAS Bus Second Level Strength Control**
 - 0 Normal slew rate control..... default
 - 1 More slew rate control
- 1 Virtual Channel-DRAM Enable**
 - 0 Disable default
 - 1 Enable
- 0 Multi-Page Open**
 - 0 Disable (page registers marked invalid and no page register update which causes non page-mode operation)
 - 1 Enable default

Device 0 Offset 6C - SDRAM Control (00h).....RW

- 7-5 **Reserved** always reads 0
- 4 **CKE Configuration**
 - 0 Rx6B[4]=0 CSA = CSA, CSB = CSB,
CKE0=CKE0, CKE1 = CKE1
 - x Rx6B[4]=1 CSA = CSA, CSB = Float,
CSB = Float, MAB = Float,
CKE0 = CKE0, CKE1 = CKE0
 - 1 Rx6B[4]=0 CSA = CSA, CSB = CSB,
CKE3-2 = CSA7-6
CKE5-4 = CSB7-6
CKE1 = GCKE (Global CKE)
CKE0 = FENA (FET Enable)
- 3 **Fast TLB Lookup**
 - 0 Disabledefault
 - 1 Enable
- 2-0 **SDRAM Operation Mode Select**
 - 000 Normal SDRAM Modedefault
 - 001 NOP Command Enable
 - 010 All-Banks-Precharge Command Enable
(CPU-to-DRAM cycles are converted
to All-Banks-Precharge commands).
 - 011 MSR Enable
CPU-to-DRAM cycles are converted to
commands and the commands are driven on
MA[14:0]. The BIOS selects an appropriate
host address for each row of memory such that
the right commands are generated on
MA[14:0].
 - 100 CBR Cycle Enable (if this code is selected,
CAS-before-RAS refresh is used; if it is not
selected, RAS-Only refresh is used)
 - 101 Reserved
 - 11x Reserved

Device 0 Offset 6D - DRAM Drive Strength (00h)..... RW

- 7 **ESDRAM Memory Type**
 - 0 Disable..... default
 - 1 Enable
- 6-5 **Delay DRAM Read Latch**
 - 00 No Delay..... default
 - 01 0.5 ns
 - 10 1.0 ns
 - 11 1.5 ns
- 4 **Memory Data Drive (MD, MECC)**
 - 0 6 mA default
 - 1 8 mA
- 3 **SDRAM Command Drive (SRAS#, SCAS#, SWE#)**
 - 0 16mA default
 - 1 24mA
- 2 **Memory Address Drive (MA, WE#)**
 - 0 16mA default
 - 1 24mA
- 1 **CAS# Drive**
 - 0 8 mA default
 - 1 12 mA
- 0 **RAS# Drive**
 - 0 16mA default
 - 1 24mA

Device 0 Offset 6E - ECC Control (00h).....RW

- 7 ECC / EC Mode Select**
 - 0 ECC Checking and Reportingdefault
 - 1 ECC Checking, Reporting, and Correcting
- 6 Reserved** always reads 0
- 5 Enable SERR# on ECC / EC Multi-Bit Error**
 - 0 Don't assert SERR# for multi-bit errors..... def
 - 1 Assert SERR# for multi-bit errors
- 4 Enable SERR# on ECC / EC Single-Bit Error**
 - 0 Don't assert SERR# for single-bit errors..... def
 - 1 Assert SERR# for single-bit errors
- 3 ECC / EC Enable - Bank 7/6 (DIMM 3)**
 - 0 Disable (no ECC or EC for banks 7/6)...default
 - 1 Enable (ECC or EC per bit-7)
- 2 ECC / EC Enable - Bank 5/4 (DIMM 2)**
 - 0 Disable (no ECC or EC for banks 5/4)...default
 - 1 Enable (ECC or EC per bit-7)
- 1 ECC / EC Enable - Bank 3/2 (DIMM 1)**
 - 0 Disable (no ECC or EC for banks 3/2)...default
 - 1 Enable (ECC or EC per bit-7)
- 0 ECC / EC Enable - Bank 1/0 (DIMM 0)**
 - 0 Disable (no ECC or EC for banks 1/0)...default
 - 1 Enable (ECC or EC per bit-7)

Device 0 Offset 6F - ECC Status (00h)..... RWC

- 7 Multi-bit Error Detected**..... write of '1' resets
- 6-4 Multi-bit Error DRAM Bank**..... default=0
Encoded value of the bank with the multi-bit error.
- 3 Single-bit Error Detected**..... write of '1' resets
- 2-0 Single-bit Error DRAM Bank** default=0
Encoded value of the bank with the single-bit error.

Error checking / correction may be enabled bank-pair by bank-pair (DIMM by DIMM) by using bits 0-2 above. Bank pairs must be populated with 72-bit memory to enable for EC or ECC since the additional data bits must be present in either case. For this reason, if 64-bit memory is populated in a particular bank pair, the corresponding bit 0-2 should be set to 0 to disable both EC and ECC for that bank pair. For those bank pairs that have 72-bit memory available (and have the corresponding bit 0-2 set), either EC or ECC may be selected via bit-7 above (i.e., all enabled bank pairs will use EC or all will use ECC).

If error checking / reporting only (EC) is selected, all read and write cycles will use normal timing. Partial writes (with EC or ECC enabled) will use read-modify-write cycles to maintain correct error correction codes in the additional 8 data bits. If EC and ECC are disabled for a particular bank pair, partial writes to that bank pair will use the byte enables to write only the selected bytes (using normal write cycles and cycle timing). If error correction (ECC) is selected, the first read of a transaction will always have one additional cycle of latency.

Bit-7 Bits 2-0 RMW Error Checking Error Correction

0/1	0	No	No	No
	0	Yes	Yes	No
	1	Yes	Yes	Yes

PCI Bus Control

These registers are normally programmed once at system initialization time.

Device 0 Offset 70 - PCI Buffer Control (00h).....RW

- 7 CPU to PCI Post-Write**
 - 0 Disabledefault
 - 1 Enable
- 6 PCI Master to DRAM Post-Write**
 - 0 Disabledefault
 - 1 Enable
- 5 Reserved** always reads 0
- 4 PCI Master to DRAM Prefetch**
 - 0 Disabledefault
 - 1 Enable
- 3 Enhance CPU-to-PCI Write**
 - 0 Normal operationdefault
 - 1 Reduce 1 cycle when the CPU-to-PCI buffer becomes available after being full (PCI and AGP buses)
- 2 PCI Master Read Caching**
 - 0 Disabledefault
 - 1 Enable
- 1 Delay Transaction**
 - 0 Disabledefault
 - 1 Enable
- 0 Slave Device Stopped Idle Cycle Reduction**
 - 0 Normal Operation.....default
 - 1 Reduce 1 PCI idle cycle when stopped by a slave device (PCI and AGP buses)

Device 0 Offset 71 - CPU to PCI Flow Control 1 (00h). RW

- 7 Dynamic Burst**
 - 0 Disable..... default
 - 1 Enable (see note under bit-3 below)
- 6 Byte Merge**
 - 0 Disable..... default
 - 1 Enable
- 5 Reserved** always reads 0
- 4 PCI I/O Cycle Post Write**
 - 0 Disable..... default
 - 1 Enable
- 3 PCI Burst**
 - 0 Disable..... default
 - 1 Enable (bit7=1 will override this option)
- bit-7 bit-3 Operation**
 - 0 0 Every write goes into the write buffer and no PCI burst operations occur.
 - 0 1 If the write transaction is a burst transaction, the information goes into the write buffer and burst transfers are later performed on the PCI bus. If the transaction is not a burst, PCI write occurs immediately (after a write buffer flush).
 - 1 x Every write transaction goes to the write buffer; burstable transactions will then burst on the PCI bus and non-burstable won't. This is the normal setting.
- 2 PCI Fast Back-to-Back Write**
 - 0 Disable..... default
 - 1 Enable
- 1 Quick Frame Generation**
 - 0 Disable..... default
 - 1 Enable
- 0 1 Wait State PCI Cycles**
 - 0 Disable..... default
 - 1 Enable

Device 0 Offset 72 - CPU to PCI Flow Control 2 (00h) RWC

- 7 Retry Status**
 - 0 No retry occurreddefault
 - 1 Retry occurred..... **write 1 to clear**
- 6 Retry Timeout Action**
 - 0 Retry Forever (record status only).....default
 - 1 Flush buffer for write or return all 1s for read
- 5-4 Retry Limit**
 - 00 Retry 2 timesdefault
 - 01 Retry 16 times
 - 10 Retry 4 times
 - 11 Retry 64 times
- 3 Clear Failed Data and Continue Retry**
 - 0 Flush the entire post-write bufferdefault
 - 1 When data is posting and master (or target) abort fails, pop the failed data if any, and keep posting
- 2 CPU Backoff on PCI Read Retry Failure**
 - 0 Disabledefault
 - 1 Backoff CPU when reading data from PCI and retry fails
- 1 Reduce 1T for FRAME# Generation**
 - 0 Disabledefault
 - 1 Enable
- 0 Reduce 1T for CPU read PCI slave**
 - 0 DisableDefault
 - 1 Enable

Device 0 Offset 73 - PCI Master Control 1 (00h)..... RW

- 7 Reserved**always reads 0
- 6 PCI Master 1-Wait-State Write**
 - 0 Zero wait state TRDY# response default
 - 1 One wait state TRDY# response
- 5 PCI Master 1-Wait-State Read**
 - 0 Zero wait state TRDY# response default
 - 1 One wait state TRDY# response
- 4 Reserved**always reads 0
- 3 Assert STOP# after PCI Master Write Timeout**
 - 0 Disable..... default
 - 1 Enable
- 2 Assert STOP# after PCI Master Read Timeout**
 - 0 Disable..... default
 - 1 Enable
- 1 LOCK# Function**
 - 0 Disable..... default
 - 1 Enable
- 0 PCI Master Broken Timer Enable**
 - 0 Disable..... default
 - 1 Enable. Force into arbitration when there is no FRAME# 16 PCICLK's after the grant.

Device 0 Offset 74 - PCI Master Control 2 (00h)..... RW

- 7 PCI Master Read Prefetch by Enhance Command**
 - 0 Always Prefetch default
 - 1 Prefetch only if Enhance command
- 6 Reserved (Do Not Program)** default = 0
- 5 Reserved**always reads 0
- 4 Dummy Request**..... default = 0
- 3 PCI Delay Transaction Timeout**
 - 0 Disable..... default
 - 1 Enable
- 2 Backoff CPU Immediately on CPU-to-AGP**
 - 0 Disable..... default
 - 1 Enable
- 1-0 CPU/PCI Master Latency Timer Control**
 - 00 AGP master reloads MLT timer default
 - 01 AGP master falling edge reloads MLT timer
 - 10 AGP master rising edge resets timer to 00 and AGP master falling edge reloads MLT timer
 - 11 Reserved (do not program)

Device 0 Offset 75 - PCI Arbitration 1 (00h)RW

- 7 Arbitration Mechanism**
 - 0 PCI has prioritydefault
 - 1 Fair arbitration between PCI and CPU
- 6 Arbitration Mode**
 - 0 REQ-based (arbitrate at end of REQ#)...default
 - 1 Frame-based (arbitrate at FRAME# assertion)
- 5-4 Latency Timer** read only, reads Rx0D bits 2:1
- 3-0 PCI Master Bus Time-Out**
(force into arbitration after a period of time)
 - 0000 Disabledefault
 - 0001 1x32 PCICLKs
 - 0010 2x32 PCICLKs
 - 0011 3x32 PCICLKs
 - 0100 4x32 PCICLKs
 -
 - 1111 15x32 PCICLKs

Device 0 Offset 76 - PCI Arbitration 2 (00h)..... RW

- 7 PCI CPU-to-PCI Post-Write Retry Failed**
 - 0 Continue retry attempt default
 - 1 Go to arbitration
- 6 CPU Latency Timer Bit-0**RO
 - 0 CPU has at least 1 PCLK time slot when CPU has PCI bus
 - 1 CPU has no time slot
- 5-4 Master Priority Rotation Control**
 - 0x Grant to CPU after every PCI master grant
.....def=00
 - 10 Grant to CPU after every 2 PCI master grants
 - 11 Grant to CPU after every 3 PCI master grants

With setting 01, the CPU will always be granted access after the current bus master completes, no matter how many PCI masters are requesting. With setting 10, if other PCI masters are requesting during the current PCI master grant, the highest priority master will get the bus after the current master completes, but the CPU will be guaranteed to get the bus after that master completes. With setting 11, if other PCI masters are requesting, the highest priority will get the bus next, then the next highest priority will get the bus, then the CPU will get the bus. In other words, with the above settings, even if multiple PCI masters are continuously requesting the bus, the CPU is guaranteed to get access after every master grant (01), after every other master grant (10) or after every third master grant (11).
- 3-2 Select REQn to RQ4 mapping**
 - 00 REQ4
 - 01 REQ0
 - 10 REQ1
 - 11 REQ2
- 1 C2P QW High DW read access to PCI slave allow to be backoff**
 - 0 Disable default
 - 1 Enable
- 0 Enable RQ4 as high priority master**
 - 0 Disable default
 - 1 Enable

Device 0 Offset 77 - Chip Test Mode (00h)..... RW

- 7 Reserved (no function)** always reads 0
- 6-0 Reserved (do not use)** default=0

Device 0 Offset 78 - PMU Control I (00h).....RW

- 7 **I/O Port 22 Access**
 - 0 CPU access to I/O address 22h is passed on to the PCI busdefault
 - 1 CPU access to I/O address 22h is processed internally
- 6 **Suspend Refresh Type**
 - 0 CBR Refreshdefault
 - 1 Self Refresh
- 5 **Reserved** always reads 0
- 4 **Dynamic Clock Control**
 - 0 Normal (clock is always running).....default
 - 1 Clock to various internal functional blocks is disabled when those blocks are not being used
- 3 **Reserved** always reads 0
- 2 **GSTOP# Assertion**
 - 0 Disable (GSTOP# is always high).....default
 - 1 Enable (GSTOP# could be low)
- 1 **Reserved** always reads 0
- 0 **Memory Clock Enable (CKE) Function**
 - 0 CKE Function Disable.....default
 - 1 CKE Function Enable

Device 0 Offset 79 - PMU Control 2 (00h)RW

- 7 **Cache Controller Module Clock Dynamic Stop**
 - 0 Disabledefault
 - 1 Enable
- 6 **DRAM Controller Module Clock Dynamic Stop**
 - 0 Disabledefault
 - 1 Enable
- 5 **AGP Controller Module Clock Dynamic Stop**
 - 0 Disabledefault
 - 1 Enable
- 4 **PCI Controller Module Clock Dynamic Stop**
 - 0 Disabledefault
 - 1 Enable
- 3 **Pseudo Power Good**
 - 0 Disabledefault
 - 1 Enable
- 2 **Indicate SIO Request to DRAM Controller**
 - 0 Disabledefault
 - 1 Enable
- 1-0 **Reserved** always reads 0

Device 0 Offset 7A – Miscellaneous Control 1 (00h)..... RW

- 7 **No Time-Out Arbitration for Consecutive Frame Accesses**
 - 0 Enable default
 - 1 Disable
- 6-5 **Reserved** always reads 0
- 4 **Invalidate PCI / AGP Buffered (Cached) Read Data for CPU to PCI / AGP Accesses**
 - 0 Enable default
 - 1 Disable
- 3 **Background PCI-to-PCI Write Cycle Mode**
 - 0 Disable..... default
 - 1 Enable
- 2-1 **Reserved** always reads 0
- 0 **South Bridge PCI Master Force Timeout When PCI Master Occupancy Timer Is Up**
 - 0 Disable..... default
 - 1 Enable

Device 0 Offset 7B – Miscellaneous Control 2 (02h)..... RW

- 7-2 **Reserved** always reads 0
- 1 **PCI Master Access PMRDY Select**
 - 0 Tail
 - 1 Head default
- 0 **PCI Bus Operating Freq.....strapped from MAB5#**
 - 0 33 MHz..... default
 - 1 66 MHz

Device 0 Offset 7E – PLL Test Mode (00h) RW

- 7-6 **Reserved (status)**RO
- 5-0 **Reserved (do not use)** default=0

Device 0 Offset 7F – PLL Test Mode (00h) RW

- 7-0 **Reserved (do not use)** default=0

GART / Graphics Aperture Control

The function of the Graphics Address Relocation Table (GART) is to translate virtual 32-bit addresses issued by an AGP device into 4K-page based physical addresses for system memory access. In this translation, the upper 20 bits (A31-A12) are remapped, while the lower 12 address bits (A11-A0) are used unchanged.

A one-level fully associative lookup scheme is used to implement the address translation. In this scheme, the upper 20 bits of the virtual address are used to point to an entry in a page table located in system memory. Each page table entry contains the upper 20 bits of a physical address (a "physical page" address). For simplicity, each page table entry is 4 bytes. The total size of the page table depends on the GART range (called the "aperture size") which is programmable in the VT82C694X.

This scheme is shown in the figure below.

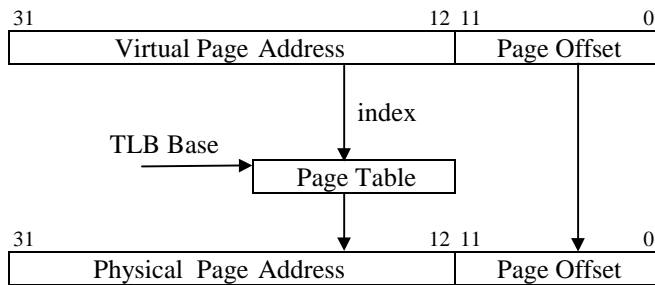

Figure 5. Graphics Aperture Address Translation

Since address translation using the above scheme requires an access to system memory, an on-chip cache (called a "Translation Lookaside Buffer" or TLB) is utilized to enhance performance. The TLB in the VT82C694X contains 16 entries. Address "misses" in the TLB require an access of system memory to retrieve translation data. Entries in the TLB are replaced using an LRU (Least Recently Used) algorithm.

Addresses are translated only for accesses within the "Graphics Aperture" (GA). The Graphics Aperture can be any power of two in size from 1MB to 256MB (i.e., 1MB, 2MB, 4MB, 8MB, etc). The base of the Graphics Aperture can be anywhere in the system virtual address space on an address boundary determined by the aperture size (e.g., if the aperture size is 4MB, the base must be on a 4MB address boundary). The Graphics Aperture Base is defined in register offset 10 of device 0. The Graphics Aperture Size and TLB Table Base are defined in the following register group (offsets 84 and 88 respectively) along with various control bits.

Device 0 Offset 83-80 - GART/TLB Control (0000000h) RW

- 31-16 Reserved always reads 0
- 15-8 Reserved (test mode status)..... RO
- 7 **Flush Page TLB**
 - 0 Disabledefault
 - 1 Enable
- 6-4 **Reserved (always program to 0)** RW
- 3 **PCI Master Address Translation for GA Access**
 - 0 Addresses generated by PCI Master accesses of the Graphics Aperture will not be translated default
 - 1 PCI Master GA addresses will be translated
- 2 **AGP Master Address Translation for GA Access**
 - 0 Addresses generated by AGP Master accesses of the Graphics Aperture will not be translated default
 - 1 AGP Master GA addresses will be translated
- 1 **CPU Address Translation for GA Access**
 - 0 Addresses generated by CPU accesses of the Graphics Aperture will not be translated def
 - 1 CPU GA addresses will be translated
- 0 **AGP Address Translation for GA Access**
 - 0 Addresses generated by AGP accesses of the Graphics Aperture will not be translated def
 - 1 AGP GA addresses will be translated

Note: For any master access to the Graphics Aperture range, snoop will not be performed.

Device 0 Offset 84 - Graphics Aperture Size (00h) RW

- 7-0 **Graphics Aperture Size**
 - 11111111 1M
 - 11111110 2M
 - 11111100 4M
 - 11111000 8M
 - 11110000 16M
 - 11100000 32M
 - 11000000 64M
 - 10000000 128M
 - 00000000 256M

Offset 8B-88 - GA Translation Table Base (00000000h) RW

- 31-12 **Graphics Aperture Translation Table Base.**
Pointer to the base of the translation table in system memory used to map addresses in the aperture range (the pointer to the base of the "Directory" table).
- 11-3 **Reserved**always reads 0
- 2 **TLB Flush Timing**
 - 0 TLB Flush Will Delay Until DRAM Is Idle default
 - 1 TLB Flush Is A Static Value
- 1 **Graphics Aperture Enable**
 - 0 Disable default
 - 1 Enable

Note: To disable the Graphics Aperture, set this bit to 0 and set all bits of the Graphics Aperture Size to 0. To enable the Graphics Aperture, set this bit to 1 and program the Graphics Aperture Size to the desired aperture size.

- 0 **Reserved**always reads 0

AGP Control

Device 0 Offset A3-A0 - AGP Capability Identifier (00200002h)RO

- 31-24 Reserved** always reads 00h
- 23-20 Major Specification Revision** always reads 2h
Major rev of AGP spec that device conforms to (2.x)
- 19-16 Minor Specification Revision** always reads 0h
Minor rev # of AGP spec that device conforms to
- 15-8 Pointer to Next Item**..... always reads 00 (last item)
- 7-0 AGP ID** .. (always reads 02 to indicate it is AGP)

Device 0 Offset A7-A4 - AGP Status (1F000203h)RO

- 31-24 Maximum AGP Requests** always reads 1F†
Max # of AGP requests the device can manage (32)
† See also RxFC[1] and RxFD[4-0]
- 23-10 Reserved**always reads 0s
- 9 Supports SideBand Addressing** always reads 1
- 8-6 Reserved**always reads 0s
- 5 4G Supported** (can be written at RxAE[5] def=0
- 4 Fast Wr Supported** (can be written at AE[4]... def=0
- 3 Reserved**always reads 0s
- 2 4X Rate Supported** (can be written at AE[2]).. def=0
- 1 2X Rate Supported** (can be written at AC[3]).. def=1
- 0 1X Rate Supported**..... always reads 1

Device 0 Offset AB-A8 - AGP Command (00000000h) . RW

- 31-24 Request Depth** (reserved for target).. always reads 0s
- 23-10 Reserved** always reads 0s
- 9 SideBand Addressing Enable**
 - 0 Disable..... default
 - 1 Enable
- 8 AGP Enable**
 - 0 Disable..... default
 - 1 Enable
- 7-6 Reserved** always reads 0s
- 5 4G Enable**
 - 0 Disable..... default
 - 1 Enable
- 4 Fast Write Enable**
 - 0 Disable..... default
 - 1 Enable
- 3 Reserved** always reads 0s
- 2 4X Mode Enable**
 - 0 Disable..... default
 - 1 Enable
- 1 2X Mode Enable**
 - 0 Disable..... default
 - 1 Enable
- 0 1X Mode Enable**
 - 0 Disable..... default
 - 1 Enable

Device 0 Offset AC - AGP Control (08h)RW

- 7 AGP Disable** RO
 - 0 Enable.....default
 - 1 Disable
 This bit is latched from MAB9# at the rising edge of RESET#.
- 6 AGP Read Synchronization**
 - 0 Disabledefault
 - 1 Enable
- 5 AGP Read Snoop DRAM Post-Write Buffer**
 - 0 Disabledefault
 - 1 Enable
- 4 GREQ# Priority Becomes Higher When Arbiter is Parked at AGP Master**
 - 0 Disabledefault
 - 1 Enable
- 3 2X Rate Supported** (read also at RxA4[1])
 - 0 Not supported
 - 1 Supporteddefault
- 2 LPR In-Order Access (Force Fence)**
 - 0 Fence/Flush functions not guaranteed. AGP read requests (low/normal priority and high priority) may be executed before previously issued write requests.....default
 - 1 Force all requests to be executed in order (automatically enables Fence/Flush functions). Low (i.e., normal) priority AGP read requests will never be executed before previously issued writes. High priority AGP read requests may still be executed prior to previously issued write requests as required.
- 1 AGP Arbitration Parking**
 - 0 Disabledefault
 - 1 Enable (GGNT# remains asserted until either GREQ# de-asserts or data phase ready)
- 0 AGP to PCI Master or CPU to PCI Turnaround Cycle**
 - 0 2T or 3T Timing.....default
 - 1 1T Timing

Device 0 Offset AD – AGP Latency Timer (02h) RW

- 7-5 Reserved**always reads 0
- 4 Choose First or Last Ready of DRAM**
 - 0 Last ready chosen default
 - 1 First ready chosen
- 3-0 AGP Data Phase Latency Timer** default = 02h

Device 0 Offset AE – AGP Miscellaneous Control (00h)RW

- 7-6 Reserved**always reads 0
- 5 4G Supported**
 - 0 4G not supported default
 - 1 4G supported
- 4 Fast Write Supported**
 - 0 Fast Write not supported..... default
 - 1 Fast Write supported
- 3 Reserved**always reads 0
- 2 4x Rate Supported**
 - 0 4x Rate not supported default
 - 1 4x Rate supported
- 1-0 Reserved**always reads 0

Device 0 Offset B0 – AGP Pad Control / Status (8xh)....RW

- 7 AGP 4x Strobe VREF Control**
 - 0 STB VREF is STB# and vice versa
 - 1 STB VREF is AGPREFdefault
- 6 AGP 4x Strobe & GD Pad Drive Strength**
 - 0 Drive strength set to compensation circuit default.....default
 - 1 Drive strength controlled by RxB1[7-0]
- 5-3 AGP Compensation Circuit N Control Output .RO**
- 2-0 AGP Compensation Circuit P Control Output .RO**

Device 0 Offset B1 – AGP Drive Strength (63h).....RW

- 7-4 AGP Output Buffer Drive Strength N Ctrl ... def=6**
- 3-0 AGP Output Buffer Drive Strength P Ctrl.... def=3**

Device 0 Offset E0 – Miscellaneous Control (00h)RW

- 7-1 Reserved** always reads 0
- 0 Latch DRAM Data Using**
 - 0 Internal DRAM DCLK.....default
 - 1 External Feedback DRAM DCLK

Device 0 Offset F7-F0 – BIOS Scratch Registers RW

- 7-0 No hardware function** default = 0

Device 0 Offset F8 – DRAM Arbitration Timer (00h)... RW

- 7-4 AGP Timer** default = 0
- 3-0 Host CPU Timer** default = 0

Device0 Offset F9 – VGA Timer (00h)..... RW

- 7-4 VGA High Priority Timer**..... default = 0
- 3-0 VGA Timer** default = 0

Device 0 Offset FC – Back Door Control 1 (00h)..... RW

- 7-4 Priority Timer**..... default = 0
- 3-2 Reserved (Do Not Program)** default = 0
- 1 Back-Door Max # of AGP Requests**..... default = 0
 - 0 Read of RxA7 always returns a value of 7... def
 - 1 Read of RxA7 returns the value programmed in RxFD[2-0]
- 0 Back-Door Device ID Enable**..... default = 0
 - 0 Use Rx3-2 value for Rx3-2 readback..... default
 - 1 Use RxFE-FF Back-Door Device ID for Rx3-2 read

Device 0 Offset FD – Back-DoorControl 2 (00h) RW

- 7-5 Reserved** always reads 0
- 4-0 Max # of AGP Requests** default = 0
 (see also RxA7 and RxFC[1])

Device 0 Offset FF-FE – Back-Door Device ID (0000h) RW

- 15-0 Back-Door Device ID**..... default=00

Device 1 Header Registers - PCI-to-PCI Bridge

All registers are located in PCI configuration space. They should be programmed using PCI configuration mechanism 1 through CF8 / CFC with bus number of 0 and function number equal to 0 and device number equal to one.

Device 1 Offset 1-0 - Vendor ID (1106h).....RO

15-0 ID Code (reads 1106h to identify VIA Technologies)

Device 1 Offset 3-2 - Device ID (8598h).....RO

15-0 ID Code (reads 8598h to identify the VT82C694X PCI-to-PCI Bridge device)

Device 1 Offset 5-4 – Command (0007h).....RW

- 15-10 Reserved always reads 0
- 9 Fast Back-to-Back Cycle Enable RO
 - 0 Fast back-to-back transactions only allowed to the same agentdefault
 - 1 Fast back-to-back transactions allowed to different agents
- 8 SERR# Enable..... RO
 - 0 SERR# driver disableddefault
 - 1 SERR# driver enabled
 (SERR# is used to report parity errors if bit-6 is set).
- 7 Address / Data Stepping RO
 - 0 Device never does steppingdefault
 - 1 Device always does stepping
- 6 Parity Error Response.....RW
 - 0 Ignore parity errors & continuedefault
 - 1 Take normal action on detected parity errors
- 5 VGA Palette Snoop (Not Supported)..... RO
 - 0 Treat palette accesses normallydefault
 - 1 Don't respond to palette writes on PCI bus (10-bit decode of I/O addresses 3C6-3C9 hex)
- 4 Memory Write and Invalidate Command..... RO
 - 0 Bus masters must use Mem Writedefault
 - 1 Bus masters may generate Mem Write & Inval
- 3 Special Cycle Monitoring RO
 - 0 Does not monitor special cyclesdefault
 - 1 Monitors special cycles
- 2 Bus MasterRW
 - 0 Never behaves as a bus master
 - 1 Enable to operate as a bus master on the primary interface on behalf of a master on the secondary interfacedefault
- 1 Memory Space.....RW
 - 0 Does not respond to memory space
 - 1 Enable memory space accessdefault
- 0 I/O SpaceRW
 - 0 Does not respond to I/O space
 - 1 Enable I/O space accessdefault

Device 1 Offset 7-6 - Status (Primary Bus) (0220h).... RWC

- 15 Detected Parity Error always reads 0
- 14 Signaled System Error (SERR#) always reads 0
- 13 Signaled Master Abort
 - 0 No abort received default
 - 1 Transaction aborted by the master with Master-Abort (except Special Cycles)..... write 1 to clear
- 12 Received Target Abort
 - 0 No abort received default
 - 1 Transaction aborted by the target with Target-Abort write 1 to clear
- 11 Signaled Target Abort..... always reads 0
- 10-9 DEVSEL# Timing
 - 00 Fast
 - 01 Medium..... always reads 01
 - 10 Slow
 - 11 Reserved
- 8 Data Parity Error Detected always reads 0
- 7 Fast Back-to-Back Capable always reads 0
- 6 User Definable Features..... always reads 0
- 5 66MHz Capable..... always reads 1
- 4 Supports New Capability list always reads 0
- 3-0 Reserved always reads 0

Device 1 Offset 8 - Revision ID (00h)..... RO

7-0 VT82C694X Chip Revision Code (00=First Silicon)

Device 1 Offset 9 - Programming Interface (00h)..... RO

This register is defined in different ways for each Base/Sub-Class Code value and is undefined for this type of device.

7-0 Interface Identifier always reads 00

Device 1 Offset A - Sub Class Code (04h)..... RO

7-0 Sub Class Code .reads 04 to indicate PCI-PCI Bridge

Device 1 Offset B - Base Class Code (06h)..... RO

7-0 Base Class Code .. reads 06 to indicate Bridge Device

Device 1 Offset D - Latency Timer (00h)..... RO

7-0 Reserved always reads 0

Device 1 Offset E - Header Type (01h)..... RO

7-0 Header Type Code..... reads 01: PCI-PCI Bridge

Device 1 Offset F - Built In Self Test (BIST) (00h)..... RO

- 7 BIST Supported reads 0: no supported functions
- 6 Start Test write 1 to start but writes ignored
- 5-4 Reserved always reads 0
- 3-0 Response Code 0 = test completed successfully

Device 1 Offset 18 - Primary Bus Number (00h).....RW

7-0 Primary Bus Number..... default = 0
This register is read write, but internally the chip always uses bus 0 as the primary.

Device 1 Offset 19 - Secondary Bus Number (00h).....RW

7-0 Secondary Bus Number default = 0
Note: AGP must use these bits to convert Type 1 to Type 0.

Device 1 Offset 1A - Subordinate Bus Number (00h).....RW

7-0 Primary Bus Number..... default = 0
Note: AGP must use these bits to decide if Type 1 to Type 1 command passing is allowed.

Device 1 Offset 1B – Secondary Latency Timer (00h)RO

7-0 Reserved always reads 0

Device 1 Offset 1C - I/O Base (f0h).....RW

7-4 I/O Base AD[15:12]..... default = 1111b
3-0 I/O Addressing Capability..... default = 0

Device 1 Offset 1D - I/O Limit (00h).....RW

7-4 I/O Limit AD[15:12] default = 0
3-0 I/O Addressing Capability..... default = 0

Device 1 Offset 1F-1E - Secondary Status (0000h).....RO

15-0 Reserved always reads 0

Device 1 Offset 21-20 - Memory Base (fff0h).....RW

15-4 Memory Base AD[31:20] default = FFFh
3-0 Reserved always reads 0

Device 1 Offset 23-22 - Memory Limit (Inclusive) (0000h) RW

15-4 Memory Limit AD[31:20]..... default = 0
3-0 Reserved always reads 0

Device 1 Offset 25-24 - Prefetchable Memory Base (fff0h) RW

15-4 Prefetchable Memory Base AD[31:20] default = FFFh
3-0 Reserved always reads 0

Device 1 Offset 27-26 - Prefetchable Memory Limit (0000h).....RW

15-4 Prefetchable Memory Limit AD[31:20]
..... default = 0
3-0 Reserved always reads 0

Device 1 Offset 3F-3E – PCI-to-PCI Bridge Control (0000h) RW

15-4 Reserved always reads 0

3 VGA-Present on AGP

0 Forward VGA accesses to PCI Bus default
1 Forward VGA accesses to AGP Bus

Note: VGA addresses are memory A0000-BFFFFh and I/O addresses 3B0-3BBh, 3C0-3CFh and 3D0-3DFh (10-bit decode). "Mono" text mode uses B0000-B7FFFh and "Color" Text Mode uses B8000-BFFFFh. Graphics modes use Axxxxh. Mono VGA uses I/O addresses 3Bx-3Cxh and Color VGA uses 3Cx-3Dxh. If an MDA is present, a VGA will not use the 3Bxh I/O addresses and B0000-B7FFFh memory space; if not, the VGA will use those addresses to emulate MDA modes.

2 Block / Forward ISA I/O Addresses

0 Forward all I/O accesses to the AGP bus if they are in the range defined by the I/O Base and I/O Limit registers (device 1 offset 1C-1D) default
1 Do not forward I/O accesses to the AGP bus that are in the 100-3FFh address range even if they are in the range defined by the I/O Base and I/O Limit registers.

1-0 Reserved always reads 0

Device 1 Configuration Registers - PCI-to-PCI Bridge

AGP Bus Control

Device 1 Offset 40 - CPU-to-AGP Flow Control 1 (00h)RW

- 7 CPU-AGP Post Write**
0 Disabledefault
1 Enable
- 6 CPU-AGP Dynamic Burst**
0 Disabledefault
1 Enable
- 5 CPU-AGP One Wait State Burst Write**
0 Disabledefault
1 Enable
- 4 AGP to DRAM Prefetch**
0 Disabledefault
1 Enable
- 3 CPU to AGP Post Write Halt**
0 Disabledefault
1 Enable
- 2 MDA Present on AGP**
0 Forward MDA accesses to AGP.....default
1 Forward MDA accesses to PCI
Note: Forward despite IO / Memory Base / Limit
Note: MDA (Monochrome Display Adapter) addresses are memory addresses B0000h-B7FFFh and I/O addresses 3B4-3B5h, 3B8-3BAh, and 3BFh (10-bit decode). 3BC-3BE are reserved for printers.
Note: If Rx3E bit-3 is 0, this bit is a don't care (MDA accesses are forwarded to the PCI bus).
- 1 AGP Master Read Caching**
0 Disabledefault
1 Enable
- 0 AGP Delay Transaction**
0 Disabledefault
1 Enable

Table 5. VGA/MDA Memory/IO Redirection

<u>3E[3]</u>	<u>40[2]</u>	<u>VGA</u>	<u>MDA</u>	<u>Axxxx,</u>	<u>B0000</u>	<u>3Cx,</u>	
<u>VGA</u>	<u>MDA</u>	<u>is</u>	<u>is</u>	<u>B8xxx</u>	<u>-B7FFF</u>	<u>3Dx</u>	<u>3Bx</u>
<u>Pres.</u>	<u>Pres.</u>	<u>on</u>	<u>on</u>	<u>Access</u>	<u>Access</u>	<u>I/O</u>	<u>I/O</u>
0	-	PCI	PCI	PCI	PCI	PCI	PCI
1	0	AGP	AGP	AGP	AGP	AGP	AGP
1	1	AGP	PCI	AGP	PCI	AGP	PCI

Device 1 Offset 41 - CPU-to-AGP Flow Control 2 (00h) RW

- 7 Retry Status**
0 No retry occurred..... default
1 Retry Occurred**write 1 to clear**
- 6 Retry Timeout Action**
0 No action taken except to record status def
1 Flush buffer for write or return all 1s for read
- 5-4 Retry Count**
00 Retry 2, backoff CPU default
01 Retry 4, backoff CPU
10 Retry 16, backoff CPU
11 Retry 64, backoff CPU
- 3 Post Write Data on Abort**
0 Flush entire post-write buffer on target-abort or master abort..... default
1 Pop one data output on target-abort or master-abort
- 2 CPU Backoff on AGP Read Retry Timeout**
0 Disable..... default
1 Enable
- 1-0 Reserved**always reads 0

Device 1 Offset 42 - AGP Master Control (00h) RW

- 7 Read Prefetch for Enhance Command**
0 Always Perform Prefetch..... default
1 Prefetch only if Enhance Command
- 6 AGP Master One Wait State Write**
0 Disable..... default
1 Enable
- 5 AGP Master One Wait State Read**
0 Disable..... default
1 Enable
- 4 Extend AGP Internal Master for Efficient Handling of Dummy Request Cycles**
0 Disable..... default
1 Enable
This bit is normally set to 1.
- 3 AGP Delay Transaction Timeout**
0 Disable..... default
1 Enable
- 2 Prefetch Disable when Delay Transaction Occured**
0 Normal operation..... default
1 Disable prefetch when doing fast response to the previous delay transaction or doing read caching
- 1 Reserved**always reads 0
- 0 Shorten AGP Master to TRFCTL**
0 Disable..... default
1 Enable

Device 1 Offset 43 - AGP Master Latency Timer (00h) RW

- 7-4 Host to AGP Time slot**
 - 0 Disable (no timer).....default
 - 1 16 GCLKs
 - 2 32 GCLKs
 -
 - F 128 GCLKs
- 3-0 AGP Master Time Slot**
 - 0 Disable (no timer).....default
 - 1 16 GCLKs
 - 2 32 GCLKs
 -
 - F 128 GCLKs

Device 1 Offset 44 – Backdoor Register Control (00h) .RW

- 7-1 Reserved** always reads 0
- 0 Back Door Register**
 - 0 Disabledefault
 - 1 Enable

Device 1 Offset 45 – Fast Write Control (72h)..... RW

- 7 Force Fast Write Cycle to be QW Aligned**
(if Rx45[6] = 0)
 - 0 Disable..... default
 - 1 Enable
- 6 Merge Multiple CPU Transactions Into One Fast Write Burst Transaction**
 - 0 Disable
 - 1 Enable **default**
- 5 Merge Multiple CPU Write Cycles To Memory Offset 23-20 Into Fast Write Burst Cycles**
(if Rx45[6] = 0)
 - 0 Disable
 - 1 Enable **default**
- 4 Merge Multiple CPU Write Cycles To Prefetchable Memory Offset 27-24 Into Fast Write Burst Cycles** (if Rx45[6] = 0)
 - 0 Disable
 - 1 Enable **default**
- 3 Reserved** always reads 0
- 2 Fast Write Burst 4T Max (No Slave Flow Control)**
 - 0 Disable..... default
 - 1 Enable
- 1 Fast Write Fast Back to Back**
 - 0 Disable
 - 1 Enable **default**
- 0 Fast Write Initial Block 1 Wait State**
 - 0 Disable..... default
 - 1 Enable

Rx45 Bits	CPU Write Address in Mem1	CPU Write Address in Mem2	CPU Write
7-4	<u>in Mem1</u>	<u>in Mem2</u>	<u>Fast Write Cycle Alignment</u>
x1xx	-	-	QW aligned, burstable
0000	-	-	DW aligned, nonburstable
x010	0	0	n/a
0010	0	1	DW aligned, non-burstable
x010	1	-	QW aligned, burstable
x001	0	0	n/a
x001	-	1	QW aligned, burstable
0001	1	0	DW aligned, non-burstable
x011	0	0	n/a
x011	1	-	QW aligned, burstable
x011	0	1	QW aligned, burstable
1000	-	-	QW aligned, non-burstable
1010	0	1	QW aligned, non-burstable
1001	1	0	QW aligned, non-burstable

Device 1 Offset 47-46 – PCI-to-PCI Bridge Device ID...RW

15-0 PCI-to-PCI Bridge Device ID..... default = 0000

Device 1 Offset 80 – Capability ID (01h) RO

7-0 Capability ID always reads 01h

Device 1 Offset 81 – Next Pointer (00h)..... RO

7-0 Next Pointer: Null..... always reads 00h

Device 1 Offset 82 – Power Mgmt Capabilities 1 (02h).. RO

7-0 Power Mgmt Capabilities always reads 02h

Device 1 Offset 83 – Power Mgmt Capabilities 2 (00h).. RO

7-0 Power Mgmt Capabilities always reads 00h

Device 1 Offset 84 – Power Mgmt Ctrl/Status (00h)..... RW

7-2 Reserved always reads 0

1-0 Power State

00 D0 default

01 -reserved-

10 -reserved-

11 D3 Hot

Device 1 Offset 85 – Power Mgmt Status (00h)..... RO

7-0 Power Mgmt Status default = 00

Device 1 Offset 86 – P2P Br. Support Extensions (00h). RO

7-0 P2P Bridge Support Extensions..... default = 00

Device 1 Offset 87 – Power Management Data (00h) RO

7-0 Power Management Data..... default = 00

ELECTRICAL SPECIFICATIONS

Absolute Maximum Ratings

Parameter	Min	Max	Unit
Ambient operating temperature	0	55	°C
Case operating temperature	0	110	°C
Storage temperature	-55	125	°C
Input voltage	-0.5	5.5	Volts
Output voltage ($V_{CC} = 3.1 - 3.6V$)	-0.5	$V_{CC} + 0.5$	Volts

Note: Stress above the conditions listed may cause permanent damage to the device. Functional operation of this device should be restricted to the conditions described under operating conditions.

DC Characteristics

TA=0-70°C, $V_{CC}=5V\pm 5\%$, GND=0V

Symbol	Parameter	Min	Max	Unit	Condition
V_{IL}	Input low voltage	-0.50	0.8	V	
V_{IH}	Input high voltage	2.0	$V_{CC}+0.5$	V	
V_{OL}	Output low voltage	-	0.45	V	$I_{OL}=4.0mA$
V_{OH}	Output high voltage	2.4	-	V	$I_{OH}=-1.0mA$
I_{IL}	Input leakage current	-	+/-10	uA	$0 < V_{IN} < V_{CC}$
I_{OZ}	Tristate leakage current	-	+/-20	uA	$0.45 < V_{OUT} < V_{CC}$
I_{CC}	Power supply current	-		mA	

AC Timing Specifications

AC timing specifications provided are based on external zero-pf capacitance load. Min/max cases are based on the following table:

Table 6. AC Timing Min / Max Conditions

Parameter	Min	Max	Unit
3.3V Power (V_{CC} , V_{CCI} , V_{TT} , AV_{CC} , HV_{CC})	3.135	3.465	Volts
5V Reference (5VREF)	4.75	5.25	Volts
Ambient Temperature	0	55	°C

Drive strength for each output pin is programmable. See Rx6D for details.

MECHANICAL SPECIFICATIONS

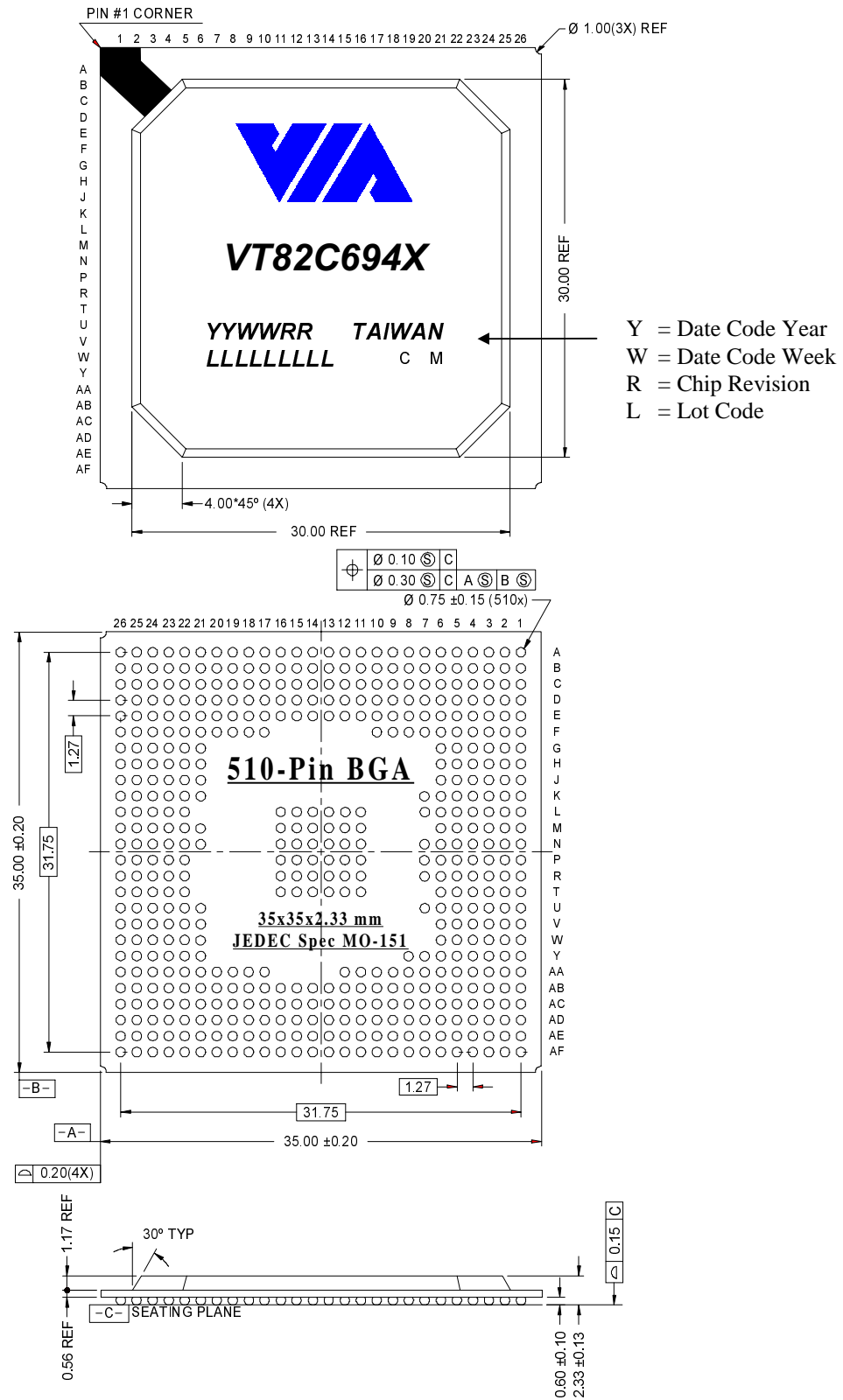

Figure 6. Mechanical Specifications - 510-Pin Ball Grid Array Package