



VT1211

**Low Pin Count
Super I/O
And Hardware Monitor**

Revision 1.37
October 8, 2003

VIA TECHNOLOGIES, INC.

Copyright Notice:

Copyright © 2000, 2001, 2002, 2003 VIA Technologies, Incorporated. Printed in the United States. ALL RIGHTS RESERVED.

No part of this document may be reproduced, transmitted, transcribed, stored in a retrieval system, or translated into any language, in any form or by any means, electronic, mechanical, magnetic, optical, chemical, manual or otherwise without the prior written permission of VIA Technologies Incorporated.

VT1211 may only be used to identify a product of VIA Technologies, Inc.



is a registered trademark of VIA Technologies, Incorporated.

Windows 98™, Windows NT™, Windows 2000™, and Plug and Play™ are registered trademarks of Microsoft Corp.

PCI™ is a registered trademark of the PCI Special Interest Group.

All trademarks are the properties of their respective owners.

Disclaimer Notice:

No license is granted, implied or otherwise, under any patent or patent rights of VIA Technologies. VIA Technologies makes no warranties, implied or otherwise, in regard to this document and to the products described in this document. The information provided by this document is believed to be accurate and reliable as of the publication date of this document. However, VIA Technologies assumes no responsibility for any errors in this document. Furthermore, VIA Technologies assumes no responsibility for the use or misuse of the information in this document and for any patent infringements that may arise from the use of this document. The information and product specifications within this document are subject to change at any time, without notice and without obligation to notify any person of such change.

Offices:

USA Office:

940 Mission Court
Fremont, CA 94539
USA
Tel: (510) 683-3300
Fax: (510) 683-3301 or (510) 687-4654
Web: <http://www.viatech.com>

Taipei Office:

8th Floor, No. 533
Chung-Cheng Road, Hsin-Tien
Taipei, Taiwan ROC
Tel: (886-2) 2218-5452
Fax: (886-2) 2218-5453
Web: <http://www.via.com.tw>

REVISION HISTORY

Document Release	Date	Revision	Initials
1.0	1/8/02	Initial release (same as internal rev 0.95 with confidential watermark removed)	DH
1.1	12/17/02	Changed Vref pin voltage to 2.2V Updated GPIO LDN8 RxF0[2-0] Fixed GPIO LDN8 RxF1 Changed T _C to 85°C	AT
1.2	2/27/03	Fixed GPIO registers Rx8[7-0]	AT
1.3	4/28/03	Added 128 Pin PQFP diagram to Mechanical Specifications	AT
1.31	5/6/03	Fixed Global control registers Rx27[7-0]	AT
1.32	5/16/03	Changed GPIO I/O space Rx07, Rx08, Rx0C-Rx0E to reserved Fixed Wake Up Control I/O Rx1C[7]	AT
1.33	5/20/03	Removed GPIO I/O Rx05 to Rx0E	AT
1.34	7/11/03	Fixed RxF0[7] in ROM Register LADN 9-D	AT
1.35	8/4/03	Fixed GP20 and GP21 pin numbers in pinouts section	AT
1.36	9/8/03	Updated Power Specification table	AT
1.37	10/8/03	Removed Watch Dog Timer Configuration RxF0	JM

TABLE OF CONTENTS

REVISION HISTORY	I
TABLE OF CONTENTS.....	II
LIST OF FIGURES	IV
LIST OF TABLES	IV
PRODUCT FEATURES.....	1
OVERVIEW	3
PINOUTS.....	4
PIN DIAGRAM	4
PIN LIST	5
PIN DESCRIPTIONS	6
REGISTERS.....	14
REGISTER OVERVIEW	14
REGISTER ORGANIZATION.....	14
CONFIGURATION SEQUENCE.....	14
REGISTER SUMMARY TABLES.....	16
Index Port and Data Port Registers	16
Configuration Space Registers	16
Logical Device Number (LDN) Assignments	16
FDC Control Registers (LDN 0).....	17
Parallel Port Control Registers (LDN 1)	17
Serial Port 1 Control Registers (LDN 2).....	17
Serial Port 2 Control Registers (LDN 3).....	17
MIDI Control Registers (LDN 6)	17
Game Port Control Registers (LDN 7).....	17
GPIO Control Registers (LDN 8).....	17
Watchdog Timer Control Registers (LDN 9)	17
Wake-Up Control Registers (LDN A).....	17
Hardware Monitor Control Registers (LDN B).....	17
Fast IR Control Registers (LDN C).....	17
ROM Control Registers (LDN D)	17
REGISTER DESCRIPTIONS	21
Chip (Global) Control Registers.....	21
Floppy Disk Controller Registers (LDN 0).....	23
Parallel Port Registers (LDN 1).....	24
Serial Port 1 Registers (LDN 2).....	25
Serial Port 2 Registers (LDN 3).....	25
MIDI Registers (LDN 6).....	26
Game Port Registers (LDN 7).....	26
GPIO Registers (LDN 8)	26
Watch Dog Registers (LDN 9)	27
Wake-Up Control Registers (LDN A).....	27
Hardware Monitor Registers (LDN B).....	27
FIR Registers (LDN C).....	27

ROM Registers (LDN D).....	27
I/O SPACE REGISTERS	28
Floppy Disk Controller I/O Registers	28
Parallel Port I/O Registers	29
Serial Port 1 I/O Registers	30
Serial Port 2 I/O Registers	31
MIDI I/O Registers	32
Game Port I/O Registers	32
GPIO I/O Registers.....	33
Watch Dog I/O Registers.....	34
Wake-Up Control I/O Registers	35
Hardware Monitor I/O Registers	39
IrDA (VFIR) Host Controller I/O Registers.....	48
ELECTRICAL SPECIFICATIONS.....	56
ABSOLUTE MAXIMUM RATINGS	56
DC CHARACTERISTICS	56
POWER SPECIFICATIONS.....	56
MECHANICAL SPECIFICATIONS.....	57

LIST OF FIGURES

FIGURE 1. VT1211 PIN DIAGRAM (TOP VIEW)	4
FIGURE 2. LPC INTERFACE BLOCK DIAGRAM	6
FIGURE 3. REGISTER MAP	15
FIGURE 4. 128-PIN LQFP – LOW-PROFILE QUAD FLAT PACK	57
FIGURE 5. 128-PIN PQFP – PLASTIC QUAD FLAT PACK	58

LIST OF TABLES

TABLE 1. VT1211 PIN LIST (ALPHABETICAL ORDER)	5
TABLE 2. PIN DESCRIPTIONS	6
TABLE 3. REGISTER SUMMARY – CONFIGURATION INDEX	16
TABLE 4. REGISTER SUMMARY – LDN ASSIGNMENTS	16
TABLE 5. REGISTER SUMMARY – LDN REGISTERS	17
TABLE 6. REGISTER SUMMARY – I/O SPACE REGISTERS	18
TABLE 7. IR OPERATIONAL MODES	49

VT1211

LPC SuperIO and Hardware Monitor

PRODUCT FEATURES

- **LPC (Low Pin Count) Interface**
 - Complies with Intel Low Pin Count Interface Specification Revision 1.0
 - Supports LDRQ#, SERIRQ protocols
- **Hardware Monitor Controller**
 - Built-in 8-bit Analog to Digital Converter
 - One thermal input for Pentium II type thermal diode
 - 1 intrinsic Vcc voltage monitor input
 - 5 external Universal Channels for monitor inputs
 - Monitors 2 fan tachometer inputs
 - 1 chassis open detection input
 - WatchDog comparison of all monitored values
 - Provides VID0 - VID4 support for P6 class CPU
 - Over temperature indicator output
 - Over limit of fan and voltage indicator output
 - Provides beep tone warning
 - Serial Bus slave mode supported
- **Fan Speed Controller**
 - Provides fan on-off and speed control
 - Supports 2 programmable Pulse Width Modulation (PWM) outputs
 - Duty cycle resolution of 1/256
- **Flash-ROM Interface**
 - Supports up to 4MB flash ROM
- **SmartGuardian Controller**
 - Provides automatic temperature to fan speed control
 - Supports mix-and-match for temperature inputs and fan speed control outputs
 - Overrides fan speed controller during catastrophic situations
 - Provides over-temperature beep tone warning
- **Two 16C550 UARTs**
 - Supports two standard Serial Ports
 - Each port supports Serial Port
- **IEEE1284 Parallel Port**
 - Standard mode -- Bi-directional SPP
 - Enhanced mode -- EPP V1.7 and 1.9 compliant
 - High speed mode -- ECP, IEEE1284 compliant
 - Backdrive current reduction
 - Printer power-on damage reduction

- **Floppy Disk Controller**
 - Supports two 360K / 720K / 1.2M / 1.44M / 2.88M floppy disk drives
 - Enhanced digital data separator
 - 3-Mode drives supported
- **Game Port**
 - Built-in 558 quad timers and buffer chips
 - Supports direct connection to two joysticks
- **Dedicated MIDI Interface**
 - UART implementation
 - Supports direct connect to MPU-401 MIDI
- **56 General Purpose I/O Pins**
 - Input mode supports switch de-bounce
 - Output mode supports one set of programmable LED blinking periods
- **Watch Dog Timer**
 - Times out the system, based on a user-programmable time-out period
 - Time resolution 1 minute, maximum 255 minutes
- **Dedicated Infrared pins**
 - Compliant with IrDA 1.4 for VFIR
- **Single 48MHz Clock Input**
- **Single 3.3V Power Supply**
- **128-pin LQFP and 128-pin PQFP**

OVERVIEW

The VT1211 is a full function Super I/O chip that provides the most commonly used legacy Super I/O functionality plus the latest Hardware monitor initiatives. The device uses an LPC interface that complies with “LPC Interface Specification Revision 1.0”.

The VT1211 contains a Floppy Disk Controller, an IEEE-1284 Parallel Port interface, two 16C550-UART-based serial port interfaces, a VFIR (Very Fast IR) Controller, a game port which supports 2 joysticks, a MIDI interface, and a 4M Flash-ROM interface. The integrated Hardware Monitor Controller controls the speed of 2 fans, monitors 2 fan tachometers, and has a Pentium II thermal diode and 5 Universal analog inputs for measuring voltage or temperature (by connecting external thermistors). The VT1211 meets the “Microsoft® PC98 & PC99 system design guide” requirements and is ACPI ready. The device requires a 48 MHz clock input and operates at 3.3V power supply.

The VT1211 consists of following logical devices. One high-performance 2.88MB floppy disk controller, with digital data separator, which supports one 360K / 720K / 1.2M / 1.44M / 2.88M floppy disk drive; One multi-mode high-performance parallel port featuring support for bi-directional Standard Parallel Port (SPP), Enhanced Parallel Port (EPP v1.7 and v1.9), and IEEE1284 compliant Extended Capabilities Port (ECP) protocols; Two 16C550 standard compatible enhanced UARTs perform asynchronous communication; One VFIR interface compliant with IrDA; One MIDI interface; One game port with built-in 558 and buffer chips to support direct connect of 2 joysticks; One Hardware Monitor; and Seven GPIO ports (56 GPIO pins).

A hardware monitor engine is built in to monitor system health. An enhanced 8 bit ADC is built inside. This is exploited to simultaneously monitor 8 analog voltages or thermal inputs. The thermal inputs can be defined independently as thermistor or Pentium™ II thermal diode. Besides the ADC, the Hardware Monitor subsystem is also equipped with one chassis-open detection and 5 VID inputs for Pentium™ II Vcore identification.

All logical devices can be individually enabled or disabled via software configuration registers.

PINOUTS

Pin Diagram

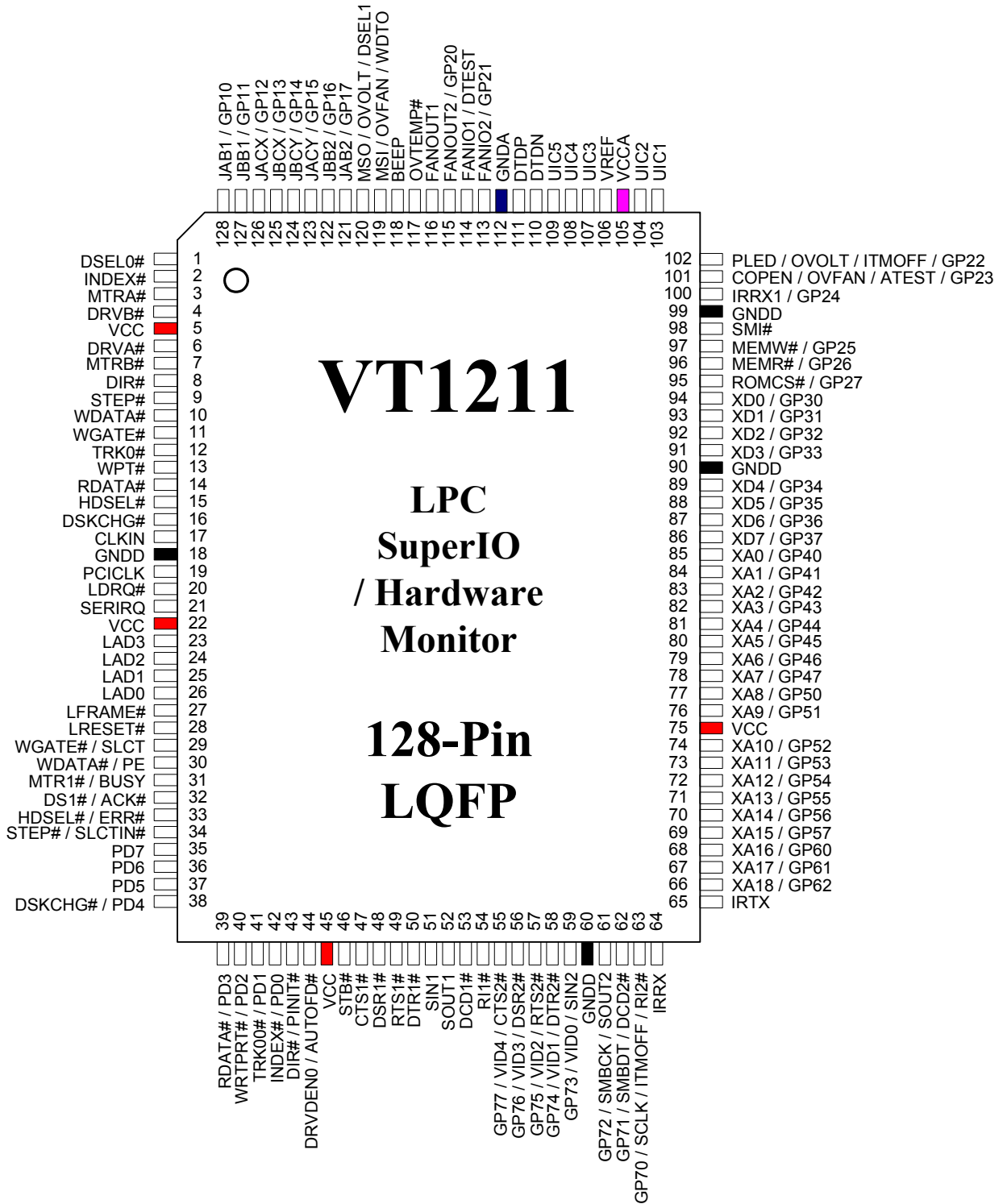

Figure 1. VT1211 Pin Diagram (Top View)

Pin List
Table 1. VT1211 Pin List (Alphabetical Order)

Pin	Signal	Pin	Signal	Pin	Signal	Pin	Signal
32	ACK#	2	INDEX#	37	PD5	105	VCCA
44	AUTOFD#	64	IRRX	36	PD6	106	VREF
118	BEEP	100	IRRX1 / GP24	35	PD7	10	WDATA#
31	BUSY	65	IRTX	30	PE	11	WGATE#
17	CLKIN	128	JAB1 / GP10	43	PINIT#	13	WPT#
101	COPEN / OVFN / GP23 / ATEST	121	JAB2 / GP17	102	PLED / OVOLT / ITMOFF / GP22	85	XA0 / GP40
47	CTS1#	126	JACX / GP12	14	RDATA#	84	XA1 / GP41
55	CTS2# / VID4 / GP77	123	JACY / GP15	54	RI1#	83	XA2 / GP42
53	DCD1#	127	JBB1 / GP11	63	RI2# / ITMOFF / SCLK / GP70	82	XA3 / GP43
62	DCD2 / GP71	122	JBB2 / GP16	95	ROMCS# / GP27	81	XA4 / GP44
8	DIR#	125	JBCX / GP13	49	RTS1#	80	XA5 / GP45
6	DRVA#	124	JBCY / GP14	57	RTS2# / VID2 / GP75	79	XA6 / GP46
4	DRVB#	26	LAD0	21	SERIRQ	78	XA7 / GP47
1	DSEL0#	25	LAD1	51	SIN1	77	XA8 / GP50
16	DSKCHG#	24	LAD2	59	SIN2 / VID0 / GP73	76	XA9 / GP51
48	DSR1#	23	LAD3	29	SLCT	74	XA10 / GP52
56	DSR2# / VID3 / GP76	20	LDRO#	34	SLCTIN#	73	XA11 / GP53
110	DTDN	27	LFRAME#	98	SMI#	72	XA12 / GP54
111	DTDP	28	LRESET#	52	SOUT1	71	XA13 / GP55
50	DTR1#	96	MEMR# / GP26	61	SOUT2 / GP72	70	XA14 / GP56
58	DTR2# / VID1 / GP74	97	MEMW# / GP25	46	STB#	69	XA15 / GP57
33	ERR#	119	MSI / OVFN / WDIO	9	STEP#	68	XA16 / GP60
114	FANIO1 / DTEST	120	MSO / OVOLT / DSEL1	12	TRK0#	67	XA17 / GP61
113	FANIO2 / GP21	3	MTRA#	103	UIC1	66	XA18 / GP62
116	FANOUT1	7	MTRB#	104	UIC2	94	XD0 / GP30
115	FANOUT2 / GP20	117	OVTEMP#	107	UIC3	93	XD1 / GP31
112	GNDA	19	PCICLK	108	UIC4	92	XD2 / GP32
18	GNDD	42	PD0	109	UIC5	91	XD3 / GP33
60	GNDD	41	PD1	5	VCC	89	XD4 / GP34
90	GNDD	40	PD2	22	VCC	88	XD5 / GP35
99	GNDD	39	PD3	45	VCC	87	XD6 / GP36
15	HDSEL#	38	PD4	75	VCC	86	XD7 / GP37

Pin Descriptions

Table 2. Pin Descriptions

LPC BUS INTERFACE			
Signal Name	Pin #	Type	Description
LRESET#	28	I	LPC Reset.
LFRAME#	27	O	LPC Frame. This signal indicates the start of an LPC cycle.
LAD[3:0]	23-26	I	LPC Address / Data 3-0. 4-bit LPC address / bidirectional data lines. LAD0 is the lsb.
LDRQ#	20	I	LPC DMA Request. An encoded signal for DMA channel select. Since there are three DMA devices in the Super I/O module (VFIR, FDC, and ECP-mode parallel port), the LPC Interface must provide LDRQ encoding for reflecting DREQ[3:0] status. Two LDRQ messages or different DMA channels may be issued back-to-back for fast tracing DMA requests. However, four PCI clocks will be inserted between two LDRQ messages of the same DMA channel to guarantee that there is at least 10 PCI clocks for one DMA request to change its status (the LPC Host will decode these LDRQ messages and send decoded DREQn to the legacy DMA controller which runs off 4MHz or 33/8 MHz).
SERIRQ	21	IO	Serial IRQ.
PCICLK	19	I	LPC Clock. 33 MHz PCI clock input.

LPC Transactions

The LPC interface in the VT1211 supports LPC Host I/O Read / Write and DMA Read / Write transactions for the Super I/O module. For LPC Host I/O Read or Write transactions, the Super I/O module processes a positive decoding, and the LPC interface can depend on its result to respond to the current transaction via sending out SYNC values on the LAD[3:0] signals or leaving LAD[3:0] in a tri-state condition. For DMA Read or Write transactions, the LPC interface depends on DMA requests from the DMA devices in the Super I/O module, and may decide to ignore the current transaction or not.

The Floppy Controller (FDC) and Parallel Port (for ECP transactions) are 8 bit DMA devices, so if the LPC Host tries to initiate a DMA transaction with a data size of 16 or 32 bits, the LPC interface will process the first 8 bit data and response with a SYNC ready (0000b) which will terminate the DMA burst. Then the LPC interface will re-issue another LDRQ message to assert DREQi after finishing the current DMA transaction.

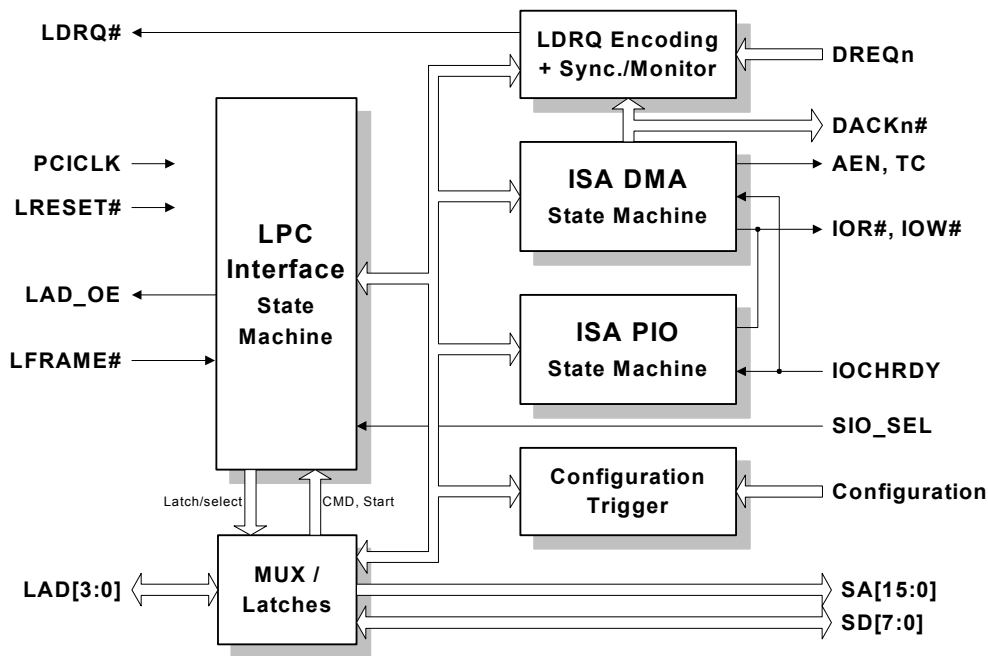

Figure 2. LPC Interface Block Diagram

Floppy Disk Controller			
Symbol	Pin #	Type	Description
DRVB#	4	O	Drive B Enable.
DRVA#	6	O	Drive A Enable.
MTRA#	3	O	Motor A Enable.
MTRB#	7	O	Motor B Enable
HSEL#	15	O	Side 1 Select.
DSEL0#	1	O	Density Select 0. High for high data rates (500Kbps, 1Mbps), low for low data rates (250Kbps, 300Kbps)
DSEL1# / MSO / OVOLT	120	O	Density Select 1.
STEP#	9	O	Step Pulse. Used to step the head in or out.
DIR#	8	O	Head Direction. Step in when low, out when high.
WGATE#	11	O	Write Gate. Low to enable write.
WDATA#	10	O	Write Serial Data. Serial data stream to the drive.
RDATA#	14	I	Read Serial Data. Serial data stream from the drive.
TRK0#	12	I	Track 0. Indicates that the head of the selected drive is on track 0.
INDEX#	2	I	Index. Indicates the beginning of a disk track.
WPT#	13	I	Write Protect. Indicates that the disk in the selected drive is write-protected.
DSKCHG#	16	I	Disk Change. Indicates whether the drive door has been opened or a diskette has been changed.

Parallel Port			
Signal Name	Pin #	Type	Description
SLCT / WGATE#	29	I / O	Printer Select. High indicates that the printer has been selected.
PE / WDATA#	30	I / O	Printer Paper End. Set high by the printer when it runs out of paper.
BUSY / MTR1#	31	I / O	Printer Busy. High indicates that the printer has a local operation in progress and cannot accept data.
ACK# / DS1#	32	I / O	Printer Acknowledge. Low indicates that the printer has received a character and is ready to accept another.
ERR# / HSEL#	33	O / O	Printer Error. Low indicates that the printer has encountered an error. The error message can be read from bit 3 of the printer status register.
SLCTIN# / STEP#	34	O / O	Printer Select Input. When low, the printer is selected. This signal is derived from the complement of bit 3 of the printer control register.
PD7 / nc, PD6 / nc, PD5 / nc, PD4 / DSKCHG#, PD3 / RDATA#, PD2 / WRTprt#, PD1 / TRK00#, PD0 / INDEX#	35-42	IO / - IO / - IO / - IO / I IO / I IO / I IO / I	Parallel Port Data Bus. This bus provides a byte-wide input or output to the system. The eight (8) lines are held in a high impedance state when the port is deselected.
PINIT# / DIR#	43	O / O	Printer Initialize. This signal is derived from bit 2 of the printer control register and is used to initialize the printer.
AUTOFD# / DRVDEN0	44	O / O	Printer Auto Line Feed. This signal is derived from the complement of bit 1 of the printer control register and is used to advance one line after each line is printed.
STB# / nc	46	O / -	Printer Strobe. This signal is the complement of bit 0 of the printer control register and is used to strobe the printing data into the printer.

As shown by the alternate functions above, in mobile applications the parallel port pins can optionally be selected to function as a floppy disk interface for attachment of an external floppy drive using the parallel port connector.

MIDI Interface			
Signal Name	Pin #	Type	Description
MSI / OVFN / WDT0	119	I	MIDI Input.
MSO / OVOLT / DSEL1	120	O	MIDI Output.

Game Port			
Signal Name	Pin #	Type	Description
JAB1 / GP10	128	I	Joystick A Button # 1 Input.
JBB1 / GP11	127	I	Joystick B Button # 1 Input.
JACX / GP12	126	I	Joystick A X-axis Resistor Input.
JBCX / GP13	125	I	Joystick B X-axis Resistor Input.
JBCY / GP14	124	I	Joystick B Y-axis Resistor Input.
JACY / GP15	123	I	Joystick A Y-axis Resistor Input.
JBB2 / GP16	122	I	Joystick B Button # 2 Input.
JAB2 / GP17	121	I	Joystick A Button # 2 Input.

Serial Port 1			
Signal Name	Pin #	Type	Description
CTS1#	47	I	Clear To Send. Low indicates that the modem is ready to accept data. CTS is a modem status input whose condition can be tested by reading the MSR register.
DSR1#	48	I	Data Set Ready. Low indicates that the modem ("Data Set") is ready to establish a communications link. DSR is a modem status input whose condition can be tested by reading the MSR register.
RTS1#	49	O	Request To Send. Low indicates to the modem that the device is ready to send data. RTS is activated by setting the appropriate bit in the register of MCR to 1. After a Master Reset operation or during Loop mode, RTS is set to its inactive state.
DTR1#	50	O	Data Terminal Ready. DTR is used to indicate to the modem that the device is ready to exchange data. DTR is activated by setting the appropriate bit in the register of MCR to 1. After a Master Reset operation or during Loop mode, DTR is set to its inactive state.
SIN1	51	I	Serial Data In. This input receives serial data from the communications link.
SOUT1	52	O	Serial Data Out. This output sends serial data to the communications link. This signal is set to a marking state (logic 1) after a Master Reset operation or when the device is in one of the Infrared communications modes.
DCD1#	53	I	Data Carrier Detect. Low indicates that the modem has detected a carrier. The DCD# signal is a modem status input whose condition can be tested by reading the MSR.
RI1#	54	I	Ring Indicator. Low indicates that a telephone ring signal has been received by the modem. The RI signal is a modem status input whose condition can be tested by reading the MSR register.

Serial Port 2			
Signal Name	Pin #	Type	Description
CTS2# / VID4 / GP77	55	I I IO	Clear To Send. The default function of this pin is Clear To Send. Low indicates that the modem is ready to accept data. The CTS signal is a modem status input whose condition can be tested by reading the MSR register.
DSR2# / VID3 / GP76	56	I I IO	Data Set Ready. The default function of this pin is Data Set Ready. Low indicates that the modem (“Data Set”) is ready to establish a communications link. The DSR signal is a modem status input whose condition can be tested by reading the MSR register.
RTS2# / VID2 / GP75	57	O O IO	Request To Send. The default function of this pin is Request To Send. Low indicates to the modem that the device is ready to send data. RTS is activated by setting the appropriate bit in the register of MCR to 1. After a Master Reset operation or during Loop mode, RTS is set to its inactive state.
DTR2# / VID1 / GP74	58	O I IO	Data Terminal Ready 2. The default function of this pin is Data Terminal Ready. DTR is used to indicate to the modem that the device is ready to exchange data. DTR is activated by setting the appropriate bit in the register of MCR to 1. After a Master Reset operation or during Loop mode, DTR is set to its inactive state.
SIN2# / VID0 / GP73	59	I I IO	Serial Data In. The default function of this pin is Serial Data In. This input receives serial data from the communications link.
SOUT2# / SMBCK / GP72	61	O IO IO	Serial Data Out. The default function of this pin is Serial Data Out. This output sends serial data to the communications link. This signal is set to a marking state (logic 1) after a Master Reset operation or when the device is in one of the Infrared communications modes.
DCD2# / SMBDT / GP71	62	I IO IO	Data Carrier Detect. The default function of this pin is Data Carrier Detect. Low indicates that the modem has detected a carrier. DCD is a modem status input whose condition can be tested by reading the MSR.
RI2# / GP70 / ITMOFF / SCLK	63	I IO	Ring Indicator. The default function of this pin is Ring Indicator. Low indicates that a telephone ring signal has been received by the modem. The RI signal is a modem status input whose condition can be tested by reading the MSR register.

Infrared (IR) Controller			
Signal Name	Pin #	Type	Description
IRTX	65	O	Infrared Data Transmit. Infrared Data Transmit.
IRRX	64	IO	Infrared Data Receive. Infrared Data Receive for SIR or FIR.
IRRX1 / GP24	100	I	Infrared Data Receive 1. The default function of this pin is Infrared Data Receive for SIR or transceiver mode control. The function of this pin decided by the GPIO configuration register.
ITMOFF / SCLK / GP70 / RI2#	63	IO	Infrared Transceiver Module Off. IR Transceiver Module On / Off control
SCLK / ITMOFF / GP70 / RI2#	63	IO	IR Transceiver Serial Clock. For devices that meet specification 1.0 “Serial Interface of Transceiver Control”

General Purpose I/O Group 1			
Signal Name	Pin #	Type	Description
GP10 / JAB1	128	IO	General Purpose I/O 10.
GP11 / JBB1	127	IO	General Purpose I/O 11.
GP12 / JACX	126	IO	General Purpose I/O 12.
GP13 / JBCX	125	IO	General Purpose I/O 13.
GP14 / JBCY	124	IO	General Purpose I/O 14.
GP15 / JACY	123	IO	General Purpose I/O 15.
GP16 / JBB2	122	IO	General Purpose I/O 16.
GP17 / JAB2	121	IO	General Purpose I/O 17.

General Purpose I/O Group 2			
Signal Name	Pin #	Type	Description
GP20 / FANOUT2	115	IO	General Purpose I/O 20.
GP21 / FANIO2	113	IO	General Purpose I/O 21.
GP22 / PLED / ITMOFF / OVOLT	102	IO	General Purpose I/O 22.
GP23 / COPEN / OVFAN / ATEST	101	IO	General Purpose I/O 23.
GP24 / IRRX1	100	IO	General Purpose I/O 24.
GP25 / MEMW#	97	IO	General Purpose I/O 25.
GP26 / MEMR#	96	IO	General Purpose I/O 26.
GP27 / ROMCS#	95	IO	General Purpose I/O 27.

General Purpose I/O Group 3			
Signal Name	Pin #	Type	Description
GP30 / XD0	94	IO	General Purpose I/O 30.
GP31 / XD1	93	IO	General Purpose I/O 31.
GP32 / XD2	92	IO	General Purpose I/O 32.
GP33 / XD3	91	IO	General Purpose I/O 33.
GP34 / XD4	89	IO	General Purpose I/O 34.
GP35 / XD5	88	IO	General Purpose I/O 35.
GP36 / XD6	87	IO	General Purpose I/O 36.
GP37 / XD7	86	IO	General Purpose I/O 37.

General Purpose I/O Group 4			
Signal Name	Pin #	Type	Description
GP40 / XA0	85	IO	General Purpose I/O 40.
GP41 / XA1	84	IO	General Purpose I/O 41.
GP42 / XA2	83	IO	General Purpose I/O 42.
GP43 / XA3	82	IO	General Purpose I/O 43.
GP44 / XA4	81	IO	General Purpose I/O 44.
GP45 / XA5	80	IO	General Purpose I/O 45.
GP46 / XA6	79	IO	General Purpose I/O 46.
GP47 / XA7	78	IO	General Purpose I/O 47.

General Purpose I/O Group 5			
Signal Name	Pin #	Type	Description
GP50 / XA8	77	IO	General Purpose I/O 50.
GP51 / XA9	76	IO	General Purpose I/O 51.
GP52 / XA10	74	IO	General Purpose I/O 52.
GP53 / XA11	73	IO	General Purpose I/O 53.
GP54 / XA12	72	IO	General Purpose I/O 54.
GP55 / XA13	71	IO	General Purpose I/O 55.
GP56 / XA14	70	IO	General Purpose I/O 56.
GP57 / XA15	69	IO	General Purpose I/O 57.

General Purpose I/O Group 6			
Signal Name	Pin #	Type	Description
GP60 / XA16	68	O	General Purpose Output 60.
GP61 / XA17	67	O	General Purpose Output 61.
GP62 / XA18	66	O	General Purpose Output 62.

General Purpose I/O Group 7			
Signal Name	Pin #	Type	Description
GP70 / RI2# / ITMOFF / SCLK	63	IO	General Purpose I/O 70.
GP71 / DCD2# / SMBDT	62	IO	General Purpose I/O 71.
GP72 / SOUT2#/SMBCK	61	IO	General purpose I/O 72.
GP73 / SIN2# / VID0	59	IO	General Purpose I/O 73.
GP74 / DTR2# / VID1	58	IO	General Purpose I/O 74.
GP75 / RTS2# / VID2	57	IO	General purpose I/O 75.
GP76 / DSR2# / VID3	56	IO	General Purpose I/O 76.
GP77 / CTS2# / VID4	55	IO	General purpose I/O 77.

Hardware Monitor			
Signal Name	Pin #	Type	Description
UIC[1:5]	103, 104, 107-109	I	Universal Input Channels 1–5. 0 to 2.60 V FSR Analog Inputs.
VREF	106	O	Reference Voltage Output. Regulated referenced voltage for external temperature sensors. It can drive 3 thermistors (max.) and Vref = 2.2V
DTDP	111	I	Thermal Diode Anode. Pentium thermal diode input positive junction.
DTDN	110	I	Thermal Diode Cathode. Pentium thermal diode input negative junction.
VID0 / GP73 / SIN2	59	I	Voltage ID 0. The Voltage ID is the voltage supply read outs from P6 CPUs. This value is read in the VID register. The configuration of this pin is decided by the GPIO configuration registers.
VID1 / GP74 / DTR2#	58	I	Voltage ID 1. The Voltage ID is the voltage supply read outs from P6 CPUs. This value is read in the VID register. The configuration of this pin is decided by the GPIO configuration registers.
VID2 / GP75 / RTS2#	57	I	Voltage ID 2. The Voltage ID is the voltage supply read outs from P6 CPUs. This value is read in the VID register. The configuration of this pin is decided by the GPIO configuration registers.
VID3 / GP76 / DSR2#	56	I	Voltage ID 3. The Voltage ID is the voltage supply read outs from P6 CPUs. This value is read in the VID register. The configuration of this pin is decided by the GPIO configuration registers.
VID4 / GP77 / CTS2#	55	I	Voltage ID 4. The Voltage ID is the voltage supply read outs from P6 CPUs. This value is read in the VID register. The configuration of this pin is decided by the GPIO configuration registers.
COPEN / OV7AN / GP23 / ATEST	101	IO	Case Open Detection. Indicates that the case is open.
OVTEMP#	117	O	Over Temperature. Indicates the thermal sensor is out of the high limit.
OVFAN / WDTO / MSI	119	O	Over Fan Limit. Indicates the fan speed is out of limit.
OVOLT / DSEL1 / MSO	120	O	Over Voltage Limit. Indicates the power supply voltage is out of the high or low limits.
BEEP	118	O	Beep Warning. Warning that the hardware monitor has detected a fatal error in system resources.
SMBDT / GP71 / DCD2#	62	IO	Serial Bus Data. Serial bus bi-directional data.
SMBCK / GP72 / SOUT2	61	IO	Serial Bus Clock. Serial Bus clock.
FANIO1 / DTEST	114	I	Fan Tachometer Input 1. 0 to +5V amplitude fan tachometer input.
FANIO2 / GP21	113	I	Fan Tachometer Input 2. 0 to +5V amplitude fan tachometer input.
FANOUT1	116	O	Fan Speed Control Output 1. PWM output signal to fan FET.
FANOUT2 / GP20	115	O	Fan Speed Control Output 2. PWM output signal to fan FET.
WDTO / OV7AN / MSI	119	O	Watch Dog Time Out.

Flash ROM Interface			
Signal Name	Pin #	Type	Description
XA[18-16] / GP[62-60], XA[15-8] / GP[57-50], XA[7-0] / GP[47-40]	66-68, 69-74, 76-77, 78-85	O	ROM Address[18:0]. The default function of these pins is for flash ROM address input. The function of these pins decided by the GPIO configuration register.
XD7-XD0 / GP[37-30]	86-89, 91-94	IO	ROM Data[7:0]. The default function of these pins is for flash ROM data input. The function configuration of these pins decided by the GPIO configuration register.
ROMCS# / GP27	95	O	ROM Chip Select. The default function of this pin is for ROM chip select input. The function of this pin decided by the GPIO configuration register.
MEMR# / GP26	96	O	Memory Read. The default function of this pin is memory read enable. The function of this pin decided by the GPIO configuration register.
MEMW# / GP25	97	O	Memory Write. The default function of this pin is for a memory write enable. The function of this pin decided by the GPIO configuration register.

Miscellaneous			
Signal Name	Pin #	Type	Description
PLED / OVOLT / ITMOFF / GP22	102	IO	Power Indicator. The default function of this pin is an indicator of power on after system reset. The function of this pin determined by the GPIO configuration register.
SMI#	98	O	System Management Interrupt.
CLKIN	17	I	48 MHz Clock.

Strap Configuration			
Signal Name	Pin #	Type	Description
BADDR	49	I	Base Address. Sampled at reset to determine the base address of the configuration index / data register pair, as follows: 10K external pull-up resistor selects 2Eh / 2Fh. 10K external pull-down resistor selects 4Eh / 4Fh.
TEST	50	I	Test. Force the device into test mode if an external pull-up resistor is connected. Otherwise, this pin should be pulled-down by an external resistor for normal operation.
ENFROM	52	I	Enable Flash ROM. Enabled Flash-ROM Interface if an external pull-up resistor is connected. Otherwise, the Flash ROM pins function as GPIO ports (from pin 66 to pin 97).

Power Supplies			
Signal Name	Pin #	Type	Description
VCC	5, 22, 45, 75	Power	Digital Power. 3.3V
VCCA	105	Power	Analog Power.
GNDD	18, 60, 90, 99	Ground	Digital Ground.
GND A	112	Ground	Analog Ground.

Note 1: A combination of high frequency decoupling capacitors is suggested on all analog power / ground pairs.

Note 2: All grounds should be connected to the primary circuit board ground plane (i.e., to the lowest impedance point available).

REGISTERS

Register Overview

The following tables summarize the configuration and I/O registers of the VT1211. These tables also document the power-on default value (“Default”) and access type (“Acc”) for each register. Access type definitions used are RW (Read/Write), RO (Read/Only), “—” for reserved / used (essentially the same as RO), and RWC (or just WC) (Read / Write 1’s to Clear individual bits). Registers indicated as RW may have some read/only bits that always read back a fixed value (usually 0 if unused); registers designated as RWC or WC may have some read-only or read write bits (see individual register descriptions for details).

Detailed register descriptions are provided in the following section of this document. All offset and default values are shown in hexadecimal unless otherwise indicated.

Register Organization

From the **Index Port and Data Port Register** table, the two registers can be accessed to enter Configuration mode by writing a specific value (87h) to Configuration Index Register twice.

Logical Device Number (LDN) Assignments table shows that each function block is associated with a Logical Device Number (LDN). The configuration registers are grouped into banks, where each bank holds the standard configuration registers according to its assigned logical device.

Figure presents the standard structure of the configuration register file. The Super I/O control and configuration registers are not banked and are only accessed by the Index Port and Data Port register. The device control and device configuration registers are duplicated over 14 banks for 14 logical devices. Therefore, by accessing a specific register in a specific bank is performed by two-step procedure. The LDN register will first locate the logical device and the Index register will select the register within that function block.

Configuration Sequence

Accessing a specific device control and device configuration register can be achieved through three basic steps:

- a) Enter configuration mode
- b) Configure the chip
- c) Escape from configuration mode

Enter Configuration Mode

To place the chip into the configuration mode, two successive writes of 87h must be applied to Configuration Index Register 2Eh or 4Eh.

Configure the Chip

The Logical Device can be selected from as:

1. Write 07h to Configuration Index Register 2Eh or 4Eh
2. Write the number of the desired logical device to Configuration Data Register 2Fh or 4Fh

The super I/O configuration registers can be read/write from/to as:

1. Write index to Configuration Index Register 2Eh or 4Eh
2. Read/write data from/to Configuration Data Register 2Fh or 4Fh

Escape from Configuration Mode

Write AAh to the Configuration Index Register to disable SuperI/O configuration mode.

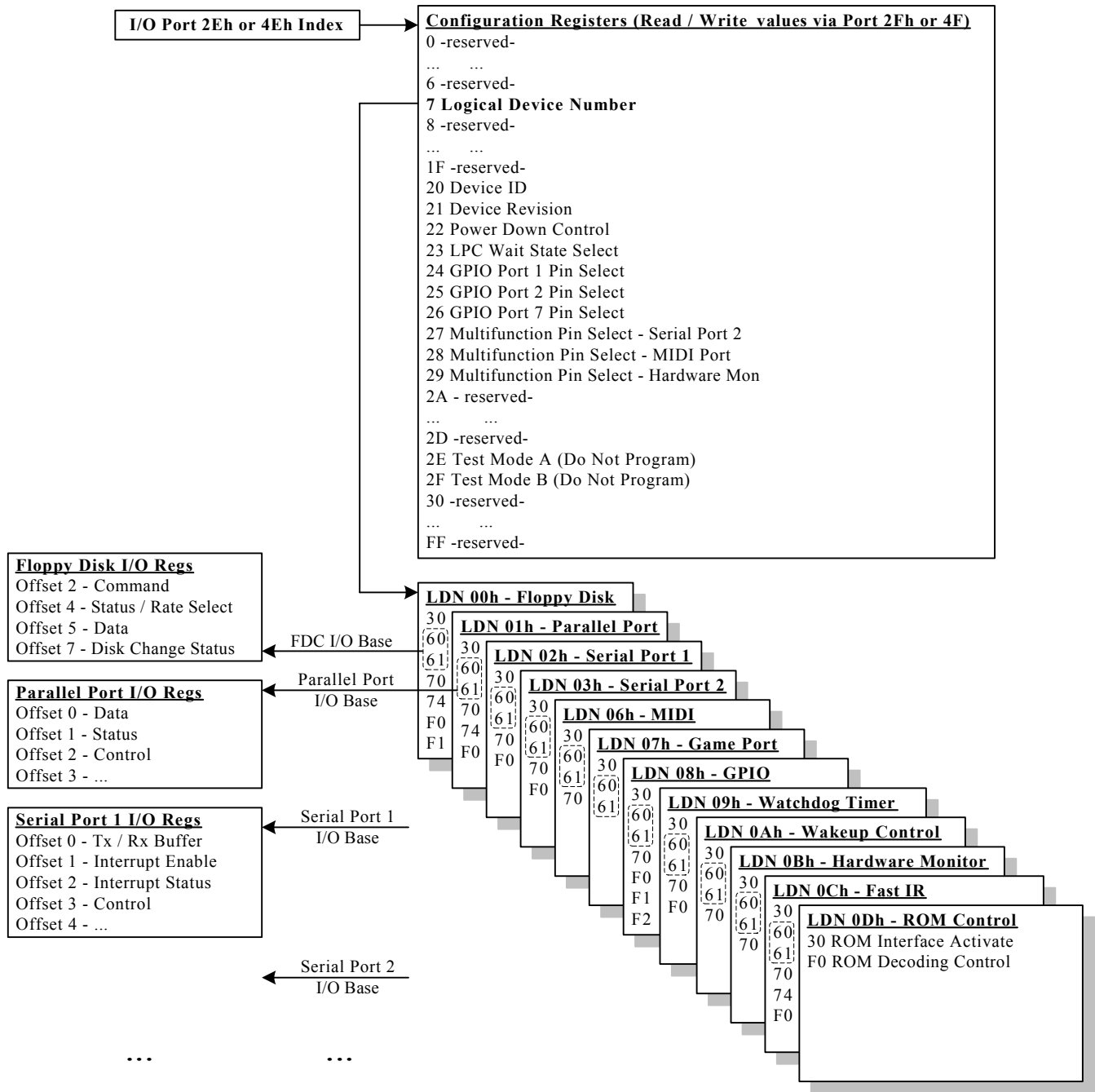

Figure 3. Register Map

Register Summary Tables

Table 3. Register Summary – Configuration Index

Index Port and Data Port Registers

I/O Port	Function	Default	Acc
2E or 4E	Configuration Index	00	RW
2F or 4F	Configuration Data	00	RW

Configuration Space Registers

Offset	Super I/O Control	Default	Acc
0-6	-reserved-	00	–
7	Logical Device Number	–	RW
8-1F	-reserved-	00	–
20	Device ID	3C	RO
21	Device Revision	01	RO
22	Power Down Control	00	RW
23	LPC Wait State Select	11	RW
24	GPIO Port 1 Pin Select	00	RW
25	GPIO Port 2 Pin Select	00	RW
26	GPIO Port 7 Pin Select	00	RW
27	UART2 Multi Function Pin Select	11	RW
28	MIDI Multi Function Pin Select	00	RW
29	HWM Multifunction Pin Select	00	RW
2A-2D	-reserved-	00	–
2E	Test Mode A (Do not Program)	00	RW
2F	Test Mode B (Do not Program)	00	RW
30-FF	-reserved-	00	–

Note: All offsets and default values above are in hexadecimal.

Table 4. Register Summary – LDN Assignments

Logical Device Number (LDN) Assignments

LDN	Functional Block
00	Floppy Disk Controller (FDC)
01	Parallel Port (PP)
02	Serial Port 1 (UART1)
03	Serial Port 2 (UART2)
04	-reserved-
05	-reserved-
06	MIDI
07	Game Port (GMP)
08	GPIO
09	Watch Dog (WDG)
0A	Wake-up Control (WUC)
0B	Hardware Monitor (HM)
0C	Very Fast IR (VFIR)
0D	Flash ROM (ROM)

Note: All offsets above are in hexadecimal.

See following page for LDN register summary tables

Table 5. Register Summary – LDN Registers
FDC Control Registers (LDN 0)

Offset	Floppy Disk Controller	Default	Acc
30	Floppy Controller Activate	00	RW
61-60	FDC I/O Base Address	03F0	RW
70	FDC IRQ Select	06	RW
74	FDC DRQ Select	01	RW
F0	Floppy Controller Configuration	00	RW
F1	Floppy Drive Select	00	RW

Parallel Port Control Registers (LDN 1)

Offset	Parallel Port	Default	Acc
30	Parallel Port Activate	03	RW
61-60	Parallel Port I/O Base Address	0378	RW
70	Parallel Port IRQ Select	05	RW
74	Parallel Port DRQ Select	00	RW
F0	Parallel Port Control	00	RW

Serial Port 1 Control Registers (LDN 2)

Offset	Serial Port 1	Default	Acc
30	Serial Port 1 Activate	00	RW
61-60	Serial Port 1 I/O Base Address	03F8	RW
70	Serial Port 1 IRQ Select	04	RW
F0	Serial Port 1 Control	00	RW

Serial Port 2 Control Registers (LDN 3)

Offset	Serial Port 2	Default	Acc
30	Serial Port 2 Activate	00	RW
61-60	Serial Port 2 I/O Base Address	02F8	RW
70	Serial Port 2 IRQ Select	03	RW
F0	Serial Port 2 Control	00	RW

MIDI Control Registers (LDN 6)

Offset	MIDI	Default	Acc
30	MIDI Activate	00	RW
61-60	MIDI I/O Base Address	0330	RW
70	MIDI IRQ Select	00	RW

Game Port Control Registers (LDN 7)

Offset	Game Port	Default	Acc
30	Game Port Activate	00	RW
61-60	Game Port I/O Base Address	0200	RW

Note: All offsets and default values above are in hexadecimal.

GPIO Control Registers (LDN 8)

Offset	General Purpose I/O	Default	Acc
30	GPIO Activate	00	RW
61-60	GPIO I/O Base Address	E900	RW
70	GPIO Event IRQ Select	00	RW
F0	GPIO Port Select	00	RW
F1	GPIO Pin Configuration	00	RW
F2	GPIO Pin Polarity Define	00	RW

Watchdog Timer Control Registers (LDN 9)

Offset	Watch Dog Controller	Default	Acc
30	Watch Dog Activate	00	RW
61-60	Watch Dog I/O Base Address	EA00	RW
70	Watch Dog IRQ Select	00	RW

Wake-Up Control Registers (LDN A)

Offset	Wake-Up Controller	Default	Acc
30	WUC Activate	00	RW
61-60	WUC I/O Base Address	EB00	RW
70	WUC IRQ Select	00	RW

Hardware Monitor Control Registers (LDN B)

Offset	Hardware Monitor	Default	Acc
30	Hardware Monitor Activate	00	RW
61-60	Hardware Monitor Address	EC00	RW
70	Hardware Monitor IRQ Select	00	RW

Fast IR Control Registers (LDN C)

Offset	FIR Controller	Default	Acc
30	FIR Activate	00	RW
61-60	FIR I/O Base Address	E800	RW
70	FIR IRQ Select	00	RW
74	FIR DRQ Select	06	RW
F0	FIR One DMA Selection	00	RW

ROM Control Registers (LDN D)

Offset	ROM Controller	Default	Acc
30	ROM Interface Activate	01	RW
F0	ROM Decoding Control	00	RW

Note: All offsets and default values above are in hexadecimal.

Table 6. Register Summary – I/O Space Registers
FDC I/O Space Registers

Offset	Base = LDN 0 Rx61-60 (03F0h)	Default	Acc
02	FDC Command	00	RW
04	FDC Main Status	00	RO
04	FDC Data Rate Select	–	WO
05	FDC Data	00	RW
07	FDC Disk Change Status	00	RW

Parallel Port I/O Space Registers

Offset	Base = LDN 1 Rx61-60 (0378h)	Default	Acc
00	Parallel Port Data	00	RW
01	Parallel Port Status	00	RO
02	Parallel Port Control	00	RW
03	Parallel Port EPP Address	00	RW
04	Parallel Port EPP Data 0	00	RW
05	Parallel Port EPP Data 1	00	RW
06	Parallel Port EPP Data 2	00	RW
07	Parallel Port EPP Data 3	00	RW
400	Parallel Port ECP Data / Config A	00	RW
401	Parallel Port ECP Configuration B	00	RW
402	Parallel Port ECP Extended Control	00	RW

Serial Ports 1 & 2 I/O Space Registers

Offset	Port 1 Base = LDN 2 Rx61-60 Port 2 Base = LDN 3 Rx61-60	Default	Acc
00	Transmit / Receive Buffer	00	RW
01	Interrupt Enable	00	RW
01-00	Baud Rate Generator Divisor	00	RW
02	Interrupt Status	00	RO
02	FIFO Control	–	WO
03	UART Control	00	RW
04	Handshake Control	00	RW
05	UART Status	00	RW
06	Handshake Status	00	RW
07	Scratchpad	00	RW

Serial Port 1 base address default = 03F8h; Port 2 = 02F8h

MIDI Port I/O Space Registers

Offset	Base = LDN 6 Rx61-60 (0330h)	Default	Acc
00	MIDI Data	00	RW
01	MIDI Status	00	RO
01	MIDI Control	–	WO

Game Port I/O Space Registers

Offset	Base = LDN 7 Rx61-60 (0200h)	Default	Acc
01	Game Port Status	00	RO
01	Start Game Port One Shot	00	WO

Note: All offsets and default values above are in hexadecimal.

GPIO I/O Space Registers

Offset	Base = LDN 8 Rx61-60 (E900h)	Default	Acc
00	GPIO Port 0 Data	00	RW
01	GPIO Port 3 Data	00	RW
02	GPIO Port 4 Data	00	RW
03	GPIO Port 5 Data	00	RW
04	GPIO Port 6 Data	00	RW

Watchdog Timer I/O Space Registers

Offset	Base = LDN 9 Rx61-60 (EA00h)	Default	Acc
00	Watchdog Status	01	RO
01	Watchdog Mask	00	RW
02	Watchdog Timeout	00	RW

Wakeup I/O Space Registers

Offset	Base = LDN A Rx61-60 (EB00h)	Default	Acc
00	Wake-Up Status 0	00	RW
01	Wake-Up Status 1	00	RW
03	Wake-Up Event Enable 0	00	RW
04	Wake-Up Event Enable 1	00	RW
06	Wake-Up Configuration	00	RW
08	GPIO Port 0 Data	00	RW
09	GPIO Port 1 Data	00	RW
0A	Module IRQ Status 0	00	RO
0B	Module IRQ Status 1	00	RO
0C	Module IRQ Enable 0	00	RW
0D	Module IRQ Enable 1	00	RW
0E	SMI # Event Enable 0	00	RW
0F	SMI # Event Enable 1	00	RW
11	IRQ Event Enable 0	00	RW
12	IRQ Event Enable 1	00	RW
1C	Event Configuration	00	RW
1D	Event Debounce Enable	00	RW
1E	Event Polarity Type	00	RW
1F	Event Trigger Type	00	RW
20	GP2x Output Enable	00	RW
21	GP2x Polarity Inversion	00	RW
22	GP7x Output Enable	00	RW
23	GP7x Polarity Inversion	00	RW

Note: All offsets and default values above are in hexadecimal.

Hardware Monitor I/O Space Registers

Offset	Base = LDN B Rx61-60 (EC00h)	Default	Acc
10	SELD0 [7:0] For AFE as Digital filter parameter SELD [7:0]	00	RW
11	SELD1[7:0] for as SELD[15:8]	00	RW
12	SELD2[7:0] for as SELD[19:16]	00	RW
13	Analog data D[15:8]	00	RW
14	Analog data D[7:0]	00	RW
15	Digital data D[7:0]	00	RW
16	Channel Counter	00	RW
17	Data Valid & Channel Indications.	00	RW
18	SMBus Control (For Noise Avoiding)	00	RW
19	AFE Control	00	RW
1A	AFE Test Control	00	RW
1B	Channel Setting	00	RW
1C	-reserved-	00	-
1D	Hot Temp Limit (H) for temp reading 3	00	RW
1E	Hot Temp Hysteresis Limit (Low)	00	RW
1F	Temperature reading 1 (for Intel CPU Thermal Diode)	00	RW
20	Temperature Reading 3 (Reserved for Internal Thermal Diode)	00	RW
21	UCH 1 ,Default as Thermal input (Temperature reading 2) that setting for NTC type thermistor input	00	RW
22	UCH 2, Default for Voltage inputs	00	RW
23	UCH 3, Default for Voltage inputs	00	RW
24	UCH 4, Default for Voltage inputs	00	RW
25	UCH 5, Default for Voltage inputs	00	RW
26	+3.3V(Internal Vdd)	00	RW
27-28	-reserved-	00	-
29	FAN1 reading	00	RW
2A	FAN 2 reading	00	RW
2B	UCH2 High Limit	00	RW
2C	UCH2 Low Limit	00	RW
2D	UCH3 High Limit	00	RW
2E	UCH3 Low Limit	00	RW
2F	UCH4 High Limit	00	RW
30	UCH4 Low Limit	00	RW
31	UCH5 High Limit	00	RW
32	UCH5 Low Limit	00	RW
33	Internal +3.3V High Limit	00	RW
34	Internal +3.3V Low Limit	00	RW
35 - 38	- reserved -	00	-
39	Hot Temp Limit (H) for temp reading 1	00	RW
3A	Hot Temp Hysteresis Limit (Low)	00	RW

Note: All offsets and default values above are in hexadecimal.

3B	FAN 1 Fan Count Limit (FIN0)	00	RW
3C	FAN 2 Fan Count Limit (FIN1)	00	RW
3D	UCH1 High Limit (default for temp reading 2)	00	RW
3E	UCH1 Low Limit	00	RW
3F	Stepping ID number	00	RW
40	Configuration	08	RW
41	Interrupt INT Status 1	00	RO
42	Interrupt INT Status 2	00	RO
43	INT Mask 1	00	RW
44	INT Mask 2	00	RW
45	VID	00	RO
46	Over Voltage & Over Fan Control	FF	RW
47	Fan Speed Control	25	RW
48	Serial Bus Address	2D	RW
49	VID 4	00	RW
4A	Universal Channel Configuration	07	RW
4B	Temperature Configuration 1	15	RW
4C	Temperature Configuration 2	55	RW
4D	Extended Temperature Resolution	00	RO
4E	Over Temperature Control	0F	RW
50	PWM Clock Select	00	RW
51	PWM Control	00	RW
52	PWM Full Speed Temperature Value	00	RW
53	PWM High Speed Temperature Value	00	RW
54	PWM Low Speed Temperature Value	00	RW
55	PWM Fan Off Temperature Value	00	RW
56	PWM Output 1 Hi Speed Duty Cycle	FF	RW
57	PWM Output 1 Lo Speed Duty Cycle	FF	RW
58	PWM Output 2 Hi Speed Duty Cycle	FF	RW
59	PWM Output 2 Lo Speed Duty Cycle	FF	RW
5A	PWM Output 3 Hi Speed Duty Cycle	FF	RW
5B	PWM Output 3 Lo Speed Duty Cycle	FF	RW
5C	BEEP Event Enable	00	RW
5D	Fan Event BEEP Frequency Divisor	00	RW
5E	Voltage Event BEEP Frequency Divisor	00	RW
5F	Temperature Event BEEP Freq Divisor	00	RW
60	PWM1 Current Duty Cycle	00	RW
61	PWM2 Current Duty Cycle	00	RW
62-7F	-reserved-	00	-

Note: All offsets and default values above are in hexadecimal.

IrDA (VFIR) Host Controller I/O Space Registers

Offset	Base = LDN C Rx61-60 (E800h)	Default	Acc
0-F	-reserved-	00	–
10	Infrared Configuration Low 0	00	RW
11	Infrared Configuration High 0	00	RW
12	Infrared SIR BOF	C0	RW
13	Infrared SIR EOF	C1	RW
14	Infrared Status High 0	00	RO
15	Infrared Status and Control 0	00	RW
16	Infrared Status Low 1	00	RO
17	Infrared Status High 1	00	RO
18	Infrared Configuration Low 1	00	RW
19	Infrared Configuration High 1	00	RW
1A	Infrared Configuration Low 2	00	RW
1B	Infrared Configuration High 2	00	RW
1E	Infrared Configuration 3	00	RW
1F	-reserved-	00	–
20	Host Control	00	RW
21	Host Status	00	RO
22	Miscellaneous Control	00	RW
23	Tx Control Low	00	RW
24	Tx Control High	40	RW
25	Tx Status	00	RO
26	Rx Control	40	RW
27	Rx Status	00	RO
28	Reset Command	00	RW
29	Packet Address	00	RW
2A	Rx Byte Count Low	00	RO
2B	Rx Byte Count High	00	RO
2C	Rx Ring Packet Pointer Low	00	RO
2D	Rx Ring Packet Pointer High	00	RO
2E	Tx Byte Count Low	00	RW
2F	Tx Byte Count High	00	RW
30-31	-reserved-	00	–
32	General Purpose Timer	00	RW
33	Infrared Configuration 4	00	RW
34	Infrared Transceiver Control Low	00	RW
35	Infrared Transceiver Control High	00	RW
36-3E	-reserved-	00	–
3F	Stepping ID	00	

Register Descriptions

Chip (Global) Control Registers

Offset 07 - Logical Device Number.....RW

7-0 **Logical Device Number**default = 00h
This register selects the current logical device.

Offset 20 - Device ID.....RO

7-0 **Device ID**default = 3Ch

Offset 21 - Device Revision.....RO

7-0 **Device Revision**default = 01h

Offset 22 - Power Down Control.....RW

7-6 **Reserved** always reads 0
5 **Clock Power Down** default = 0
4 **Parallel Port Power Down**..... default = 0
3 **Reserved** always reads 0
2 **Serial Port Power Down**..... default = 0
1 **Floppy Disk Controller Power Down**..... default = 0
0 **Reserved** always reads 0

Offset 23 - LPC Wait State Select (11h).....RW

7 **Memory Cycle Wait State Disable**.....default = 0
6-4 **LPC I/O Cycle Wait State # Selection**..... def =001b
3 **Super I/O DMA Cycle 4 Wait**..... default = 0
2-0 **LPC DMA Cycle Wait State Number Selection**
..... default = 001b

Offset 24 - GPIO Port 1 Pin Select..... RW

7 **Pin 121**
0 JAB2 default
1 GP17
6 **Pin 122**
0 JBB2 default
1 GP16
5 **Pin 123**
0 JACY default
1 GP15
4 **Pin 124**
0 JBCY default
1 GP14
3 **Pin 125**
0 JBCX default
1 GP13
2 **Pin 126**
0 JACX default
1 GP12
1 **Pin 127**
0 JBB1 default
1 GP11
0 **Pin 128**
0 JAB1 default
1 GP10

Offset 25 - GPIO Port 2 Pin Select..... RW

7 **System Reset**
0 Normal operation..... default
1 Reset chip
6 **Route SMI to Serial IRQ2**
0 Disable..... default
1 Enable
5 **Pin 97-66**
0 ROM signal default
1 GP25-GP62
4 **Pin 100**
0 IRRX1 default
1 GP24
3 **Pin 101**
0 COPEN..... default
1 GP23
2 **Pin 102**
0 PLED default
1 GP22
1 **Pin 113**
0 FANIO2 default
1 GP21
0 **Pin 115**
0 FANOUT2 default
1 GP20

Offset 26 - GPIO Port 7 Pin Select RW

7	Pin 55	
	0	CTS2#default
	1	GP77
6	Pin 56	
	0	DSR2#default
	1	GP76
5	Pin 57	
	0	RTS2#default
	1	GP75
4	Pin 58	
	0	DTR2#default
	1	GP74
3	Pin 59	
	0	SIN2default
	1	GP73
2	Pin 61	
	0	SOUT2default
	1	GP72
1	Pin 62	
	0	DCD2#default
	1	GP71
0	Pin 63	
	0	R12#default
	1	GP70

Offset 27 – Serial Port 2 Multi Function Pin Select RW

7	Pin 55	
	0	CTS2#
	1	VID4default
6	Pin 56	
	0	DSR2#
	1	VID3default
5	Pin 57	
	0	RTS2#
	1	VID2default
4	Pin 58	
	0	DTR2#
	1	VID1default
3	Pin 59	
	0	SIN2
	1	VID0default
2	Pin 61	
	0	SOUT2
	1	SMBCK.....default
1	Pin 62	
	0	DCD2#
	1	SMBDT.....default
0	Pin 63	
	0	R12#
	1	ITMOFF.....default

Offset 28 – MIDI Port Multi Function Pin Select..... RW

7	GPIO Event Group B Selection	
	0	GP4 default
	1	GP5
6	GPIO Event Group A Selection	
	0	GP1 default
	1	Depends on bit-5
5	GP Select	
		(ignored unless bit-6 = 1)
	0	GP3x default
	1	GP7x
4	Pin 102	
	0	PLED default
	1	ITMOFF
3-2	Pin 119 Bit [1:0]	
	x0	MSI default
	01	OVFAN
	11	WDTO
1-0	Pin 120 Bit [1:0]	
	x0	MSO default
	01	OVOLT
	11	DSEL1

Offset 29 – Monitor Port Multi Function Pin Select RW

7	Pin 102	
	0	Depends on Rx28[4]..... default
	1	OVOLT (Over Voltage)
6	Pin 101	
	0	COPEN..... default
	1	OVFAN (Over Fan)
5-0	Reserved always reads 0

Offset 2E – Test Mode Register A (Do Not Program)... RW
Offset 2F – Test Mode Register B (Do Not Program) ... RW

Floppy Disk Controller Registers (LDN 0)

Offset 30 – Floppy Controller ActivateRW

- 7-1 Reserved always reads 0
- 0 Floppy Disk Controller Enable default = 0

Offset 60 – Floppy Controller Base Address (FCh)RW

- 7-1 ADR9 ~ ADR3 always reads 1111 110b
- 0 Must be 0 default = 0

Offset 70 – FDC IRQ Select (06h).....RW

- 7-4 Reserved always reads 0
- 3-0 FDC Controller IRQ Number Select.... def = 0110b

Offset 74 – FDC DRQ Select (01h)RW

- 7-2 Reserved always reads 0
- 1-0 FDC DRQ Number Select default = 01b

Offset F0 – Floppy Controller Configuration RW

- 7 **Reserved** always reads 0
- 6 **Hardware Floppy Disk Drive on Parallel Port**
 - 0 Disable..... default
 - 1 Enable (see parallel port pin descriptions)
- 5 **Software Floppy Disk Drive on Parallel Port**
 - 0 Disable..... default
 - 1 Enable
- 4 **Three-Mode Floppy Disk Drive**
 - 0 Disable..... default
 - 1 Enable
- 3 **Floppy Controller IRQ Polarity**
 - 0 Positive default
 - 1 Negative
- 2 **Two / Four Floppy Disk Drive Select**
 - 0 Internal 2 drive decoder..... default
 - 1 External 4 drive decoder
- 1 **Floppy Disk Controller DMA**
 - 0 Burst default
 - 1 Non-burst
- 0 **Floppy Disk Drive Swap**
 - 0 Disable..... default
 - 1 Enable

Offset F1 – Floppy Disk Drive Type (00h)..... RW

- 7-6 **FDD3 (DT1, DT0)..... default = 00b**

	<u>DRV DEN0</u>	<u>DRV DEN1</u>
00	DENSEL	DRATE 0
01	DRATE 1	DRATE 0
10	DENSEL#	DRATE 0
11	DRATE 0	DRATE 1
- 5-4 **FDD2 (DT1, DT0)..... default = 00b**
- 3-2 **FDD1 (DT1, DT0)..... default = 00b**
- 1-0 **FDD0 (DT1, DT0)..... default = 00b**

Parallel Port Registers (LDN 1)
Offset 30 – Parallel Port Activate (03h)RW

- 7-2 **Reserved** always reads 0
- 1-0 **Parallel Port Enable**..... default = 11b
 - 00 SPP Mode
 - 01 ECP Mode
 - 10 EPP Mode
 - 11 PIO Disable

Offset 60 – Parallel Port Base Address (DEh)RW

- 7-0 **ADR9 ~ ADR2** default = 0DEh
 If EPP is not enabled, the parallel port can be set to 192 locations, on 4 bytes boundaries from 100h-3FCh. If EPP is enabled, the parallel port can be set to 96 locations, on 8 byte boundaries from 100h-3F8h. In ECP Mode, upper address decode require A10 active.

Offset 70 – Parallel Port IRQ Select (05h)RW

- 7-4 **Reserved** always reads 0
- 3-0 **Parallel Port IRQ Select**..... default = 0101b

Offset 74 – Parallel Port DRQ Select (02h).....RW

- 7-2 **Reserved** always reads 0
- 1-0 **Parallel Port DRQ Select**..... default = 10b

Offset F0 – Parallel Port Control..... RW

- 7 **PS/2 Type Bi-directional Parallel Port Enable**
 default = 0
- 6 **EPP Direction by Register not by IOW**.. default = 0
- 5 **EPP+ECP**..... default = 0
- 4 **EPP Version (0: Ver 1.9)**..... default = 0
- 3 **SPP Mode IRQ Polarity**..... default = 0
- 2-0 **Reserved** always reads 0

Serial Port 1 Registers (LDN 2)
Offset 30 – Serial Port 1 ActivateRW

- 7-1 **Reserved** always reads 0
- 0 **Serial Port 1 Function**
 - 0 Disable default
 - 1 Enable

Offset 60 – Serial Port 1 Base Address (FEh).....RW

- 7-1 **ADR9 ~ ADR3** default = 1111 111b
- 0 **Must be 0** default = 0

Offset 70 – Serial Port 1 IRQ Select (04h)RW

- 7-4 **Reserved (RO)** always reads 0
- 3-0 **Serial Port 1 IRQ Select** def = 0100b

Offset F0 – Serial Port 1 Control.....RW

- 7-4 **Must be 0** default = 0
- 3 **Serial Port 1 Output Pin Tri-State in Power Down**
 - 0 Disable default
 - 1 Enable
- 2 **Reserved** always reads 0
- 1 **Serial Port 1 High Speed**
 - 0 Disable default
 - 1 Enable
- 0 **Serial Port 1 MIDI**
 - 0 Disable default
 - 1 Enable

Serial Port 2 Registers (LDN 3)
Offset 30 – Serial Port 2 Activate..... RW

- 7-1 **Reserved** always reads 0
- 0 **Serial Port 2 Function**
 - 0 Disable default
 - 1 Enable

Offset 60 – Serial Port 2Base Address (BEh) RW

- 7-1 **ADR9 ~ ADR3** default = 1011 111b
- 0 **Must be 0** default = 0

Offset 70 – Serial Port 2 IRQ Select (03h)..... RW

- 7-4 **Reserved (RO)** always reads 0
- 3-0 **Serial Port 2 IRQ Select** default = 0011b

Offset F0 – Serial Port 2 Control RW

- 7-4 **Must be 0**
- 3 **Serial Port 2 Output Pin Tri-State in Power Down**
 - 0 Disable default
 - 1 Enable
- 2 **Reserved** always reads 0
- 1 **Serial Port 2 High Speed**
 - 0 Disable default
 - 1 Enable
- 0 **Serial Port 2 MIDI**
 - 0 Disable default
 - 1 Enable

MIDI Registers (LDN 6)

Offset 30 – MIDI Activate (00h) RW

- 7-1 **Reserved** always reads 0
- 0 **MIDI Function**
 - 0 Disable default
 - 1 Enable

Offset 61-60 – MIDI Base Address (0330h) RW

- 15-2 **MIDI I/O Base Register** default = 0330h
- 1-0 **Reserved** always reads 0

Offset 70 – MIDI IRQ Select (00h) RW

- 7-4 **Reserved** always reads 0
- 3-0 **MIDI IRQ Select** default = 0

Game Port Registers (LDN 7)

Offset 30 – Game Port Activate RW

- 7-1 **Reserved** always reads 0
- 0 **Game Port Enable** default = 0

Offset 61-60 – Game Port I/O Base Address (0200h)..... RW

- 15-3 **Game Port I/O Base** default = 020h
- 2-0 **Reserved** always reads 000b

GPIO Registers (LDN 8)

Offset 30 – GPIO Activate (00h) RW

- 7-1 **Reserved** always reads 0
- 0 **GPIO Function**
 - 0 Disable default
 - 1 Enable

Offset 61-60 – GPIO Base Address (E900h)..... RW

- 15-4 **GPIO I/O Base** default = E90h
- 3-0 **Reserved** always reads 0

Offset 70 – GPIO Event IRQ Select RW

- 7-4 **Reserved** always reads 0
- 3-0 **GPIO Event IRQ Select** default=0

Offset F0 – GPIO Port Select RW

- 7-3 **Reserved** always reads 0
- 2-0 **GPIO Port Configuration Register Bank Select** default = 0
 - 000 Select Port 1 (GPIO10~17)
 - 001 Select Port 3 (GPIO30~37)
 - 010 Select Port 4 (GPIO40~47)
 - 011 Select Port 5 (GPIO50~57)
 - 100 Select Port 6 (GPIO60~62)
 - 101 Reserved
 - ...
 - 111 Reserved

Offset F1 – GPIO Pin Configuration RW

- 7-0 **GPIO Pin Direction**
 - 0 Input default
 - 1 Output

Offset F2 – GPIO Pin Polarity RW

- 7-0 **GPIO Pin Polarity**
 - 0 Normal default
 - 1 Inverted

Watch Dog Registers (LDN 9)

Offset 30 – Watch Dog Activate (00h).....RW

- 7-1 **Reserved** default = 0
- 0 **Watch Dog Function** default = 0
 - 0 Disable default
 - 1 Enable

Offset 61-60 – Watch Dog I/O Base Address (EA00h)...RW

- 15-4 **Watch Dog I/O Base** default = EA0h
- 3-0 **Reserved** always reads 0

Offset 70 – Watch Dog IRQ Select.....RW

- 7-4 **Reserved** always reads 0
- 3-0 **Watch Dog IRQ Select** default = 0

Wake-Up Control Registers (LDN A)

Offset 30 – WUC Activate (00h)RW

- 7-1 **Reserved** always reads 0
- 0 **Wake Up Control (WUC) Function**
 - 0 Disable default
 - 1 Enable

Offset 61-60 – WUC I/O Base Address (EB00h)RW

- 15-4 **WUC I/O Base** default = EB0h
- 3-0 **Reserved** always reads 0

Offset 70 – WUC IRQ Select (00h)RW

- 7-4 **Reserved** always reads 0
- 3-0 **WUC IRQ Select** default = 0

Hardware Monitor Registers (LDN B)

Offset 30 – Hardware Monitor Activate (00h)RW

- 7-1 **Reserved** always reads 0
- 0 **Hardware Monitor Function** default = 0
 - 0 Disable default
 - 1 Enable

Offset 61-60 – HWM I/O Base Address (EC00h)RW

- 15-8 **HWM I/O Base** default = ECh
- 7-0 **Reserved** always reads 0

Offset 70 – Hardware Monitor IRQ Select.....RW

- 7-4 **Reserved** always reads 0
- 3-0 **HM IRQ Select** default = 0

FIR Registers (LDN C)

Offset 30 – Fast IR Activate (00h)..... RW

- 7-1 **Reserved** always reads 0
- 0 **Fast IR Function** default = 0
 - 0 Disable default
 - 1 Enable

Offset 61-60 – FIR I/O Base Address (E800h) RW

- 15-8 **FIR I/O Base** default = E80h
- 7-0 **Reserved** always reads 0

Offset 70 – FIR IRQ Select (00h) RW

- 7-4 **Reserved** always reads 0
- 3-0 **FIR IRQ Select** default = 0

Offset 74 – FIR DRQ Select (06h) RW

- 7-4 **Reserved** always reads 0
- 3-2 **FIR DRQ 2 Select** default = 01b
- 1-0 **FIR DRQ 1 Select** default = 10b

Offset F0 – FIR One DMA Select (00h)..... RW

- 7-1 **Reserved** always reads 0
- 0 **FIR IRQ Select** default = 0

ROM Registers (LDN D)

Offset 30 – ROM Interface Activate (01h) RW

- 7-1 **Reserved** always reads 0
- 0 **ROM Interface**
 - 0 Disable
 - 1 Enable default

Offset F0 – ROM Decoding Control (00h) RW

- 7 **Reserved** always reads 0
- 6 **FFF0000h–FFF7FFFFh** default = 0
- 5 **FFE8000h–FFEFFFFFFh** default = 0
- 4 **FFE0000h–FFE7FFFFh** default = 0
- 3 **FFD8000h–FFDF0000h** default = 0
- 2 **FFD0000h–FFD7FFFFh** default = 0
- 1 **FFC8000h–FFCFFFFFFh** default = 0
- 0 **FFC0000h–FFC7FFFFh** default = 0

Note: ROMCS# is always active for accesses to ISA Memory FFF80000h – FFFFFFFFh and 000E0000h – 000FFFFFFh.

I/O Space Registers

Floppy Disk Controller I/O Registers

These registers are normally accessed at standard FDC I/O port addresses 3F0-3F7h (see LDN 0 Rx61-60 for the FDC Port I/O Base setting).

Offset 2 – FDC CommandRW

- 7 **Motor 3 (unused in VT82C686B: no MTR3# pin)**
- 6 **Motor 2 (unused in VT82C686B: no MTR2# pin)**
- 5 **Motor 1**
 - 0 Motor Off
 - 1 Motor On
- 4 **Motor 0**
 - 0 Motor Off
 - 1 Motor On
- 3 **DMA and IRQ Channels**
 - 0 Disable
 - 1 Enable
- 2 **FDC Reset**
 - 0 Execute FDC Reset
 - 1 FDC Enable
- 1-0 **Drive Select**
 - 00 Select Drive 0
 - 01 Select Drive 1
 - 1x -reserved-

Offset 4 – FDC Main StatusRO

- 7 **Main Request**
 - 0 Data register not ready
 - 1 Data register ready
- 6 **Data Input / Output**
 - 0 CPU => FDC
 - 1 FDC => CPU
- 5 **Non-DMA Mode**
 - 0 FDC in DMA mode
 - 1 FDC not in DMA mode
- 4 **FDC Busy**
 - 0 FDC inactive
 - 1 FDC active
- 3-2 **Reserved** always reads 0
- 1 **Drive 1 Active**
 - 0 Drive inactive
 - 1 Drive performing a positioning change
- 0 **Drive 0 Active**
 - 0 Drive inactive
 - 1 Drive performing a positioning change

Offset 4 – FDC Data Rate Select WO

- 7 **Software Reset**
 - 0 Normal operation..... default
 - 1 Execute FDC reset (this bit is self clearing)
- 6 **Power Down**
 - 0 Normal operation..... default
 - 1 Power down FDC logic
- 5 **Reserved** always reads 0
- 4-2 **Precompensation Select**
Selects the amount of write precompensation to be used on the WDATA output:
 - 000 Default..... default
 - 001 41.7 ns
 - 010 93.3 ns
 - 011 125.0 ns
 - 100 166.7 ns
 - 101 208.3 ns
 - 110 250.0 ns
 - 111 0.0 ns (disable)
- 1-0 **Data Rate**

	<u>MFM</u>	<u>FM</u>	<u>Drive Type</u>
00	500K	250K bps	1.2MB 5" or 1.44 MB 3"
01	300K	150K bps	360KB 5"
10	250K	125K bps	720KB 3" default
11	1M	illegal bps	

Note: these bits are not changed by software reset

Offset 5 – FDC Data RW

Offset 7 – FDC Disk Change Status RW

- 7 **Disk Change**..... **RO**
 - 0 Floppy not changed default
 - 1 Floppy changed since last instruction
- 6-2 **Undefined** always reads 1's
- 1-0 **Data Rate** **WO**
 - 00 500 Kbit/sec (1.2MB 5" or 1.44 MB 3" drive)
 - 01 300 Kbit/sec (360KB 5" drive)
 - 10 250 Kbit/sec (720KB 3" drive)
 - 11 1 Mbit/sec

Parallel Port I/O Registers

These registers are normally accessed at standard Parallel Port I/O addresses 378-37Fh (see LDN 1 Rx61-60 for the Parallel Port I/O Base setting).

Offset 0 – Parallel Port DataRW
7-0 Parallel Port Data
Offset 1 – Parallel Port Status.....RO

- 7 BUSY#**
 - 0 Printer busy, offline, or error
 - 1 Printer not busy
- 6 ACK#**
 - 0 Data transfer to printer complete
 - 1 Data transfer to printer in progress
- 5 PE**
 - 0 Paper available
 - 1 No paper available
- 4 SLCT**
 - 0 Printer offline
 - 1 Printer online
- 3 ERROR#**
 - 0 Printer error
 - 1 Printer OK
- 2-0 Reserved** always read 1 bits

Offset 2 – Parallel Port Control.....RW

- 7-5 Undefined**always read back 1
- 4 Hardware Interrupt**
 - 0 Disabledefault
 - 1 Enable
- 3 Printer Select**
 - 0 Deselect printerdefault
 - 1 Select printer
- 2 Printer Initialize**
 - 0 Initialize Printer.....default
 - 1 Allow printer to operate normally
- 1 Automatic Line Feed**
 - 0 Host handles line feeds.....default
 - 1 Printer does automatic line feeds
- 0 Strobe**
 - 0 No data transferdefault
 - 1 Transfer data to printer

Offset 3 – Parallel Port EPP Address RW
Offset 4 – Parallel Port EPP Data Port 0 RW
Offset 5 – Parallel Port EPP Data Port 1 RW
Offset 6 – Parallel Port EPP Data Port 2 RW
Offset 7 – Parallel Port EPP Data Port 3 RW
Offset 400h – Parallel Port ECP Data / Config A..... RW
Offset 401h – Parallel Port ECP Configuration B..... RW
Offset 402h – Parallel Port ECP Extended Control RW

- 7-5 Parallel Port Mode Select**
 - 000 Standard Mode default
 - 001 PS/2 Mode
 - 010 FIFO Mode
 - 011 ECP Mode
 - 100 EPP Mode
 - 101 -reserved-
 - 110 -reserved-
 - 111 Configuration Mode
- 4 Parallel Port Interrupt Disable**
 - 0 Enable an interrupt pulse to be generated on the high to low edge of the fault. An interrupt will also be generated if the fault condition is asserted and this bit is written from 1 to 0.
 - 1 Disable the interrupt generated on the asserting edge of the fault condition
- 3 Parallel Port DMA Enable**
 - 0 Disable DMA unconditionally
 - 1 Enable DMA
- 2 Parallel Port Interrupt Pending**
 - 0 Interrupt not pending
 - 1 Interrupt pending (DMA & interrupts disabled)

This bit is set to 1 by hardware and must be written to 0 to re-enable interrupts
- 1 FIFO Full RO**
 - 0 FIFO has at least 1 free byte
 - 1 FIFO full or cannot accept byte
- 0 FIFO Empty..... RO**
 - 0 FIFO contains at least 1 byte of data
 - 1 FIFO is completely empty

Serial Port 1 I/O Registers

These registers are normally accessed at standard Parallel Port I/O addresses 3F8-3FFh (see LDN 1 Rx61-60 for the Parallel Port I/O Base setting).

Offset 0 – Transmit / Receive BufferRW

7-0 **Serial Data**

Offset 1 – Interrupt EnableRW

7-4 **Undefined** always read 0
 3 **Interrupt on Handshake Input State Change**
 2 **Intr on Parity, Overrun, Framing Error or Break**
 1 **Interrupt on Transmit Buffer Empty**
 0 **Interrupt on Receive Data Ready**

Offset 1-0 – Baud Rate Generator Divisor.....RW

15-0 **Divisor Value for Baud Rate Generator**
Baud Rate = 115,200 / Divisor
 (e.g., setting this register to 1 selects 115.2 Kbaud)

Offset 2 – Interrupt StatusRO

7-3 **Undefined** always read 0
 2-1 **Interrupt ID** (0=highest priority)
 00 Priority 3 (Handshake Input Changed State)
 01 Priority 2 (Transmit Buffer Empty)
 10 Priority 1 (Data Received)
 11 Priority 0 (Serialization Error or Break)
 0 **Interrupt Pending**
 0 Interrupt Pending
 1 No Interrupt Pending

Offset 2 – FIFO Control.....WO
Offset 3 – UART Control.....RW

7 **Divisor Latch Access**
 0 Access xmit / rcv & int enable regs at 0-1
 1 Access baud rate generator divisor latch at 0-1
 6 **Break**
 0 Break condition off
 1 Break condition on
 5-3 **Parity**
 000 None
 001 Odd
 011 Even
 101 Mark
 111 Space
 2 **Stop Bits**
 0 1
 1 2
 1-0 **Data Bits**
 00 5
 01 6
 10 7
 11 8

Offset 4 – Handshake Control..... RW

7-5 **Undefined**always read 0
 4 **Loopback Check**
 0 Normal operation
 1 Loopback enable
 3 **General Purpose Output 2 (unused in 82C686B)**
 2 **General Purpose Output 1 (unused in 82C686B)**
 1 **Request To Send**
 0 Disable
 1 Enable
 0 **Data Terminal Ready**
 0 Disable
 1 Enable

Offset 5 – UART Status..... RW

7 **Undefined**always read 0
 6 **Transmitter Empty**
 0 1 byte in transmit hold or transmit shift register
 1 0 bytes transmit hold and transmit shift regs
 5 **Transmit Buffer Empty**
 0 1 byte in transmit hold register
 1 Transmit hold register empty
 4 **Break Detected**
 0 No break detected
 1 Break detected
 3 **Framing Error Detected**
 0 No error
 1 Error
 2 **Parity Error Detected**
 0 No error
 1 Error
 1 **Overrun Error Detected**
 0 No error
 1 Error
 0 **Received Data Ready**
 0 No received data available
 1 Received data in receiver buffer register

Offset 6 – Handshake Status..... RW

7 **DCD Status (1=Active, 0=Inactive)**
 6 **RI Status (1=Active, 0=Inactive)**
 5 **DSR Status (1=Active, 0=Inactive)**
 4 **CTS Status (1=Active, 0=Inactive)**
 3 **DCD Changed (1=Changed Since Last Read)**
 2 **RI Changed (1=Changed Since Last Read)**
 1 **DSR Changed (1=Changed Since Last Read)**
 0 **CTS Changed (1=Changed Since Last Read)**

Offset 7 – Scratchpad RW

7 **Scratchpad Data**

Serial Port 2 I/O Registers

These registers are normally accessed at standard Parallel Port I/O addresses 2F8-2FFh (see LDN 1 Rx61-60 for the Parallel Port I/O Base setting).

Offset 0 – Transmit / Receive BufferRW

7-0 Serial Data

Port COM2Base+1 – Interrupt Enable.....RW

- 7-4 Undefined always read 0
- 3 Interrupt on Handshake Input State Change
- 2 Intr on Parity, Overrun, Framing Error or Break
- 1 Interrupt on Transmit Buffer Empty
- 0 Interrupt on Receive Data Ready

Offset 1-0 – Baud Rate Generator Divisor.....RW

- 15-0 Divisor Value for Baud Rate Generator
 Baud Rate = 115,200 / Divisor
 (e.g., setting this register to 1 selects 115.2 Kbaud)

Offset 2 – Interrupt StatusRO

- 7-3 Undefined always read 0
- 2-1 Interrupt ID (0=highest priority)
 - 00 Priority 3 (Handshake Input Changed State)
 - 01 Priority 2 (Transmit Buffer Empty)
 - 10 Priority 1 (Data Received)
 - 11 Priority 0 (Serialization Error or Break)
- 0 Interrupt Pending
 - 0 Interrupt Pending
 - 1 No Interrupt Pending

Offset 2 – FIFO Control.....WO
Offset 3 – UART Control.....RW

- 7 Divisor Latch Access
 - 0 Access xmit / rcv & int enable regs at 0-1
 - 1 Access baud rate generator divisor latch at 0-1
- 6 Break
 - 0 Break condition off
 - 1 Break condition on
- 5-3 Parity
 - 000 None
 - 001 Odd
 - 011 Even
 - 101 Mark
 - 111 Space
- 2 Stop Bits
 - 0 1
 - 1 2
- 1-0 Data Bits
 - 00 5
 - 01 6
 - 10 7
 - 11 8

Offset 4 – Handshake Control..... RW

- 7-5 Undefinedalways read 0
- 4 Loopback Check
 - 0 Normal operation
 - 1 Loopback enable
- 3 General Purpose Output 2 (unused in 82C686B)
- 2 General Purpose Output 1 (unused in 82C686B)
- 1 Request To Send
 - 0 Disable
 - 1 Enable
- 0 Data Terminal Ready
 - 0 Disable
 - 1 Enable

Offset 5 – UART Status..... RW

- 7 Undefinedalways read 0
- 6 Transmitter Empty
 - 0 1 byte in transmit hold or transmit shift register
 - 1 0 bytes transmit hold and transmit shift regs
- 5 Transmit Buffer Empty
 - 0 1 byte in transmit hold register
 - 1 Transmit hold register empty
- 4 Break Detected
 - 0 No break detected
 - 1 Break detected
- 3 Framing Error Detected
 - 0 No error
 - 1 Error
- 2 Parity Error Detected
 - 0 No error
 - 1 Error
- 1 Overrun Error Detected
 - 0 No error
 - 1 Error
- 0 Received Data Ready
 - 0 No received data available
 - 1 Received data in receiver buffer register

Offset 6 – Handshake Status..... RW

- 7 DCD Status (1=Active, 0=Inactive)
- 6 RI Status (1=Active, 0=Inactive)
- 5 DSR Status (1=Active, 0=Inactive)
- 4 CTS Status (1=Active, 0=Inactive)
- 3 DCD Changed (1=Changed Since Last Read)
- 2 RI Changed (1=Changed Since Last Read)
- 1 DSR Changed (1=Changed Since Last Read)
- 0 CTS Changed (1=Changed Since Last Read)

Offset 7 – Scratchpad RW

- 7 Scratchpad Data

MIDI I/O Registers

These registers are accessed at I/O port addresses offset from the MIDI I/O Base address (“Plug and Play” programmable via LDN 6 Rx61-60). The MIDI port base address register default value is 0300h so that these registers may normally be accessed at standard MIDI I/O port addresses 300-301h (but the base address may be changed via software to relocate these registers to avoid conflicts with other system I/O devices).

Offset 00h – MIDI Data InRO

Offset 00h – MIDI Data OutWO

Offset 01h – MIDI Status (80h).....RO

- 7 Receive Data Input Buffer Empty**
 - 0 Receive buffer of FIFO contains data that can be read via the MIDI Data In registerdefault
 - 1 Receive buffer is in pass-through mode or FIFO is empty
- 6 Transmit Data Output Buffer Full**
 - 0 Transmit buffer of FIFO can accept data written to the MIDI Data Out registerdefault
 - 1 Transmit buffer or FIFO cannot accept data
- 5-0 Reserved** always reads 0

Offset 01h – MIDI CommandWO

Game Port I/O Registers

These registers are accessed at I/O port addresses offset from the Game Port I/O Base address (“Plug and Play” programmable via LDN 7 Rx61-60). The game port base address register default value is 0200h so that these registers may normally be accessed at standard Game Port I/O port address 201h (but the base address may be changed via software to relocate these registers to avoid conflicts with other system I/O devices).

Offset 01h – Game Port Status RO

- 7 Joystick B Button 2 Status**
- 6 Joystick B Button 1 Status**
- 5 Joystick A Button 2 Status**
- 4 Joystick A Button 1 Status**
- 3 Joystick B One-Shot Status for Y-Potentiometer**
- 2 Joystick B One-Shot Status for X-Potentiometer**
- 1 Joystick A One-Shot Status for Y-Potentiometer**
- 0 Joystick A One-Shot Status for X-Potentiometer**

Offset 01h – Start One-Shot..... WO

- 7-0** (Value Written is Ignored)

GPIO I/O Registers

These registers are normally accessed at I/O port addresses starting at E900h (see LDN 8 Rx61-60 for the GPIO I/O Port Base setting).

Offset 00 – GPIO Port 1 Data RW

7-0 GPIO 1x Data default = 00h

If the corresponding pins are configured as outputs, this register may be used to program the output level of the corresponding GPIO pin when its output buffer is enabled. Writing to the bit latches the written data. Reading this register returns the latched value, regardless of the state of the pins.

If the corresponding pins are configured as inputs, reading this register returns the states of the corresponding GPIO pins when their output buffers are disabled (writes to this register are ignored).

The direction (I/O) configuration of the GPIO pins of this port is decided by the GPIO Configuration Register (LDN 8 RxF1) and pin functions are configured by Global Register Rx24.

Offset 01 – GPIO Port 3 Data RW

7-0 GPIO 3x Data default = 00h

If the corresponding pins are configured as outputs, this register may be used to program the output level of the corresponding GPIO pin when its output buffer is enabled. Writing to the bit latches the written data. Reading this register returns the latched value, regardless of the state of the pins.

If the corresponding pins are configured as inputs, reading this register returns the states of the corresponding GPIO pins when their output buffers are disabled (writes to this register are ignored).

The direction (I/O) configuration of the GPIO pins of this port is decided by the GPIO Configuration Register (LDN 8 RxF1) and pin functions are configured by Global Register Rx25.

Offset 02 – GPIO Port 4 Data RW

7-0 GPIO 4x Data default = 00h

If the corresponding pins are configured as outputs, this register may be used to program the output level of the corresponding GPIO pin when its output buffer is enabled. Writing to the bit latches the written data. Reading this register returns the latched value, regardless of the state of the pins.

If the corresponding pins are configured as inputs, reading this register returns the states of the corresponding GPIO pins when their output buffers are disabled (writes to this register are ignored).

The direction (I/O) configuration of the GPIO pins of this port is decided by the GPIO Configuration Register (LDN 8 RxF1) and pin functions are configured by Global Register Rx25.

Offset 03 – GPIO Port 5 Data RW

7-0 GPIO 5x Data default = 00h

If the corresponding pins are configured as outputs, this register may be used to program the output level of the corresponding GPIO pin when its output buffer is enabled. Writing to the bit latches the written data. Reading this register returns the latched value, regardless of the state of the pins.

If the corresponding pins are configured as inputs, reading this register returns the states of the corresponding GPIO pins when their output buffers are disabled (writes to this register are ignored).

The direction (I/O) configuration of the GPIO pins of this port is decided by the GPIO Configuration Register (LDN 8 RxF1) and pin functions are configured by Global Register Rx25.

Offset 04 – GPIO Port 6 Data RW

7-0 GPIO 6x Data default = 00h

If the corresponding pins are configured as outputs, this register may be used to program the output level of the corresponding GPIO pin when its output buffer is enabled. Writing to the bit latches the written data. Reading this register returns the latched value, regardless of the state of the pins.

If the corresponding pins are configured as inputs, reading this register returns the states of the corresponding GPIO pins when their output buffers are disabled (writes to this register are ignored).

The direction (I/O) configuration of the GPIO pins of this port is decided by the GPIO Configuration Register (LDN 8 RxF1) and pin functions are configured by Global Register Rx25.

Watch Dog I/O Registers

These registers are normally accessed at I/O port addresses starting at EA00h (see LDN 9 Rx61-60 for the Watch Dog I/O Port Base setting).

Offset 00 – Watch Dog Status 0 (01h)RO

- 7-1 **Reserved**..... always reads 0
- 0 **Watch Dog Time Out (WDTO).....RO**
 - 0 Timeout period has expired
 - 1 Timer still in activation or default on power up reset values.....default

Offset 01 –Watch Dog Mask (00h).....RW

- 7-3 **Reserved**..... always reads 0
- 2 **COM2 Interrupt Trigger Enable**
This bit enables the COM2 IRQ to trigger Watchdog Timer reloading and count down restart.
 - 0 COM2 IRQ is not a trigger eventdefault
 - 1 An active COM IRQ enabled as a trigger event
- 1 **COM1 Interrupt Trigger Enable**
This bit enables the COM1 IRQ to trigger Watchdog Timer reloading and count down restart.
 - 0 COM1 IRQ is not a trigger eventdefault
 - 1 An active COM1 IRQ enabled as a trigger event
- 0 **Reserved**..... always reads 0

Offset 02 – Watch Dog Timeout (00h) RW

- 7-0 **Watch Dog Timer Timeout Period**
 - 00h Timer halted, WDTO output inactive default
 - 01h Time Period 1 minute
 - 02h Time Period 2 minutes
 -
 - FFh Time Period 255 minutes

Wake-Up Control I/O Registers

These registers are normally accessed at I/O port addresses starting at EB00h (see LDN A Rx61-60 for the Wake Up Control I/O Port Base setting).

Offset 00 – Wake-Up Status RWC

- 7 Module IRQ Status**
 0 Event not active.....default
 1 Event active

This bit is only set by hardware and can only be reset by writing a 1 to this bit position.

- 6 Software Event**
 0 Event not active.....default
 1 Event active

This bit is only set and reset by writing a 1 to toggle of this bit position.

- 5 Module GPIO**
 This sticky bit shows the status of the module GPIO event detection.
 0 Event not detected.....default
 1 Event detected

This bit is only set by hardware and can only be reset by writing a 1 to this bit position.

- 4-3 Reserved always reads 0**

- 2 Ring Indicator 2#**
 0 Event not detected.....default
 1 Event detected

This bit is only set by hardware and can only be reset by writing a 1 to this bit position.

- 1 Ring Indicator 1#**
 0 Event not detected.....default
 1 Event detected

This bit is only set by hardware and can only be reset by writing a 1 to this bit position.

- 0 Reserved always reads 0**

Offset 01 – Wake-Up Status 1 RW

- 7-0 GPX [7:0] EventRWC**
 This register shows the status of either GP2X or GP7X event detection, according to register bit of Rx1C[7].
 0 Event not detected.....default
 1 Event detected

These bits are only set by hardware and can only be reset by writing a 1 to relative bit position.

Offset 03 – Wake-Up Event Enable 0 RW

- 7 Module IRQ Enable**
 0 Disable..... default
 1 Enable

- 6 Software Enable**
 0 Disable..... default
 1 Enable

- 5 Module GPIO Enable**
 0 Disable..... default
 1 Enable

- 4-3 Reserved always reads 0**

- 2 RI2# Enable**
 0 Disable..... default
 1 Enable

- 1 RI1# Enable**
 0 Disable..... default
 1 Enable

- 0 Reserved always reads 0**

Offset 04 – Wake-Up Event Enable 1 RW

- 7-0 GPX [7:0] Enable**
 This register enables event detection on the GPIO pins of either GP2X or GP7x, according to Wake-up Configuration Register Rx1C[7].
 0 Disable..... default
 1 Enable

Offset 06 – Wake-Up Configuration (00h) RW

- 7 Initialization**
 Logic 1 restores power-up default values to all of registers. This bit automatically clears itself since the power on default is zero.

- 6-5 Reserved always reads 0**

- 4 Power LED On/Off Flag**
 Logic 1 enables LED pin 102 to turn on if Wake-up Configuration Register Rx1C [2:0] are 0 (Power LED Control).

- 3-0 Reserved always reads 0**

Offset 08 – GPIO Port 0 DataRW

7-0 GPIO Data 0.....default = 00h

If this register as GPO, it should be program with the value of each bit determines the value drive on the corresponding GPIO pin when its output buffer is enabled. Writing to the bit latches the written data. Reading the bit returns its value, regardless of the pin value.

If as GPI and reads each bit should returns the value of the corresponding GPIO pin when its output buffer is disabled, regardless of the write value.

This direction (I/O) configuration of GPIO pin is decided by register of GPOUTCFG0(Reg. 20h) and pin function configured by Global Register offset 25h.

Offset 09 – GPIO Port 1 DataRW

7-0 GPIO Data 0.....default = 00h

If this register as GPO, it should be program with the value of each bit determines the value drive on the corresponding GPIO pin when its output buffer is enabled. Writing to the bit latches the written data. Reading the bit returns its value, regardless of the pin value.

If as GPI and reads each bit should returns the value of the corresponding GPIO pin when its output buffer is disabled, regardless of the write value.

The direction (I/O) configuration of the GPIO pins is decided by Rx22 and pin functions are configured by Global Register offset 26h.

Offset 0A – Module IRQ Status 0..... RO

7-0 Module IRQ [7:0] Status

This register shows the status of device IRQs (MIRQx) 7-0 detection. The MIRQ interrupts are enabled by corresponding bits of Rx0C.

- 0 IRQx undetected..... default
- 1 IRQx detected

These bits are set by hardware and can only be cleared when Module IRQ events have finished their service

Offset 0B – Module IRQ Status 1..... RO

7-0 Module IRQ [15:8] Status

This register shows the status of device IRQs (MIRQx) 15-8 detection. The MIRQ interrupts are enabled by corresponding bits of Rx0D.

- 0 IRQx undetected..... default
- 1 IRQx detected

These bits are set by hardware and can only be cleared when Module IRQ events have finished their service

Offset 0C – Module IRQ Enable 0 RW

7-0 Module IRQ [7:0] Enable

This register controls the status function of module IRQs 7-0. Each bit enables the corresponding bit of Rx0A.

- 0 IRQx undetected..... default
- 1 IRQx detected

Offset 0D – Module IRQ Enable 1 RW

7-0 Module IRQ [15:8] Enable

This register controls the status function of module IRQs 15-8. Each bit enables the corresponding bit of Rx0B.

- 0 IRQx undetected..... default
- 1 IRQx detected

Offset 0E – SMI# Event Enable 0 RW

- 7 Module IRQ**
 - 0 Disable default
 - 1 Enable
- 6 Software Enable**
 - 0 Disable default
 - 1 Enable
- 5-3 Reserved** always reads 0
- 2 RI2# Enable**
 - 0 Disable default
 - 1 Enable
- 1 RI1# Enable**
 - 0 Disable default
 - 1 Enable
- 0 Reserved** always reads 0

Offset 0F – SMI# Event Enable 1 RW

- 7-0 GPx [7:0] Enable**
This register enables the GPIO of either GP2x or GP7x event detection, according to Wake-up Configuration Register Rx1C[7].
 - 0 Disable default
 - 1 Enable

Offset 11 – IRQ Event Enable 0 RW

- 7 Module IRQ**
 - 0 Disable default
 - 1 Enable
- 6 Software Enable**
 - 0 Disable default
 - 1 Enable
- 5-3 Reserved** always reads 0
- 2 RI2# Enable**
 - 0 Disable default
 - 1 Enable
- 1 RI1# Enable**
 - 0 Disable default
 - 1 Enable
- 0 Reserved** always reads 0

Offset 12 – IRQ Event Enable 1 RW

- 7-0 GPx [7:0] Enable (GPIEN [7:0])**
This register enable the GPIO of either GP2x or GP7x event detection, according to Wake-up Configuration Register Rx1C[7].
 - 0 Disable default
 - 1 Enable

Offset 1C – Event ConfigurationRW

- 7 GPIO Event Source Select**
 - 0 Select GPIO7x as event input source
 - 1 Select GPIO2x as event input sourcedefault
- 6 Reserved** always reads 0
- 5 SMI# Output Select**
 - 0 Wake-up events that are enabled active the SMI# signal control by SMIENx register and regardless of the WUENx register.....default
 - 1 Wake-Up events status bits (see Rx01) that are enabled activate the SMI# signal on pin 98
- 4-3 Reserved** always reads 0
- 2-0 Power LED Output Control**

There are some types that are enabled activate on the PLED signal of pin 102.

 - 000 Control by Wakeup Config Rx6[4]default
 - 001 LED with 1/4 Hz toggle rate
 - 010 LED with 1/2 Hz toggle rate
 - 011 LED with 1 Hz toggle rate
 - 100 LED with 2 Hz toggle rate
 - 101 LED with 4 Hz toggle rate
 - 110 LED off
 - 111 LED constant on

Offset 1D – Event Debounce Enable.....RW

- 7-0 Event Debounce Enable**

This register enables the debounce of inputs of GPIO of either GP2x or GP7x as event inputs, according to Wake-up Configuration Register Rx1C[7].

 - 0 Disabledefault
 - 1 Enable

Offset 1E – Event Polarity.....RW

- 7-0 Event Polarity Type**

This register selects the polarity of inputs of GPIO of either GP2x or GP7x as event inputs, according to Wake-up Configuration Register Rx1C[7].

 - 0 Not Inverteddefault
 - 1 Inverted

Offset 1F – Event Trigger TypeRW

- 7-0 Event Trigger Type**

This register selects edge or level type of input for GPIO event inputs of either GP2x or GP7x, according to Wake-up Configuration Register Rx1C[7].

 - 0 Edgedefault
 - 1 Level

Offset 20 – GP2x Output Enable..... RW

- 7-0 GP2x Output Enable**

This register enables polarity inversion on the input pins of GP2x.

 - 0 GPI default
 - 1 GPO

Offset 21 – GP2x Polarity Inversion RW

- 7-0 GP2x Polarity Inversion**

This register enables polarity inversion on the input pins of GP2x.

 - 0 Disable..... default
 - 1 Enable

Offset 22 – GP7x Output Enable..... RW

- 7-0 GP7x Output Enable**

This register selects GPI or GPO functions for GP7x.

 - 0 GPI default
 - 1 GPO

Offset 23 – GP2x Polarity Inversion RW

- 7-0 GP2x Polarity Inversion**

This register enables polarity inversion on the input pins of GP7x.

 - 0 Disable..... default
 - 1 Enable

Hardware Monitor I/O Registers

These registers are normally accessed at I/O port addresses starting at EC00h (see LDN B Rx61-60 for the Hardware Monitor I/O Port Base setting).

Offset 10 – SELD0 [7:0] for AFE as Digital filter parameter SELD [7:0]RW

Offset 11 – SELD1 [7:0] for SELD [15:8]RW

Offset 12 – SELD2 [7:0] for SELD [19:16]RW

Offset 13 – Analog data D [15:8]RW

Offset 14 – Analog data D [7:0]RW

Offset 15 – Digital data D [7:0]RW

Offset 16 – Channel Counter.....RW

Offset 17 – Data Valid & Channel IndicationsRW

Offset 18 – SMBus Control Register (Noise Avoiding) ..RW

Offset 19 – AFE ControlRW

- 7 AFE Internal current source select default = 0
- 6 AFE Oscillator output select default = 0
- 5 AFE Clock source select default = 0
- 4 AFE Clock frequency select default = 0
- 3 Negative voltage input select default = 0
- 2 Cycle time select default = 0
- 1 Cycle type select default = 0
- 0 Data input select default = 0

Offset 1A – AFE Test ControlRW

- 7 BIST Enabled default = 0
- 6-4 BIST mode select default = 0
- 3-1 Reserved always reads 0
- 0 Enable channel setting default = 0

Offset 1B – Channel SettingRW

- 7-4 Reserved always reads 0
- 3-0 Channel Setting default = 0

Offset 1D – Hot Temp Limit (H) (For Temp reading 3). RW

Offset 1E – Hot Temp Hysteresis Limit (Low)..... RW

Offset 1F – Temp reading 1 (for Intel Thermal Diode).. RW

Offset 20 – Temperature Reading 3 (Reserved for Internal Thermal Diode)..... RW

Offset 21 – UCH 1 Default as Thermal input (Temperature reading 2) that setting for NTC type thermistor input.. RW

Offset 22 – UCH 2 ,Default setting for Voltage inputs... RW

Offset 23 – UCH 3 Default setting for Voltage inputs ... RW

Offset 24 – UCH 4 Default setting for Voltage inputs ... RW

Offset 25 – UCH 5 Default setting for Voltage inputs ... RW

Offset 26 – +3.3V (Internal VDD)..... RW

Offset 27 – +2.5V Sense/Vccp2 or –12v (Reserved) RW

Offset 29 – FAN1 reading RW

Note: This location stores the number of counts of the internal clock per-revolution.

Offset 2A – FAN 2 reading RW

Note: This location stores the number of counts of the internal clock per-revolution.

Offset 2B – UCH2 High Limit.....RW

Offset 2C – UCH2 Low LimitRW

Offset 2D – UCH3 High Limit.....RW

Offset 2E – UCH3 Low Limit.....RW

Offset 2F – UCH4 High LimitRW

Offset 30 – UCH4 Low LimitRW

Offset 31 – UCH5 High LimitRW

Offset 32 – UCH5 Low LimitRW

Offset 33 – Internal +3.3V High LimitRW

Offset 34 – Internal +3.3V Low LimitRW

Offset 39 – Hot Temp Limit (H) (For Temp Reading 1) RW

Offset 3A – Hot Temperature Hysteresis Limit (Low) ..RW

Offset 3B – FAN 1 Fan Count Limit (FIN0).....RW

Note: It is the number of counts of the internal clock for the Low Limit of the fan speed.

Offset 3C – FAN 2 Fan Count Limit (FIN1).....RW

Note: It is the number of counts of the internal clock for the Low Limit of the fan speed.

Offset 3D – UCH1 High Limit (Default for Temperature Reading 2) RW

Offset 3E – UCH1 Low Limit RW

Offset 3F – Stepping ID Number..... RW

Setting all ones to the high limits for voltages and fans (1111 1111 binary for temperature) means interrupts will never be generated except the case when voltages go below the low limits.

Note: For the high limits of the voltages, the device is doing a greater-than comparison. For the low limits, however, it is doing a less than or equal comparison.

Offset 40 – Configuration (08h)..... RW

- 7 Initialization**
 - 0 Power-on defaultdefault
 - 1 Restore powerup default values to the Configuration register, Interrupt Status register, Interrupt Mask registers, Fan Divisor / RST# / OS# register, and OS# Configuration / Temperature resolution register. This bit automatically clears itself.
- 6 CI Pulse** default = 0
A one outputs a minimum 20ms active low pulse on the Chassis Intrusion pin. This register bit clears itself once the pulse is output.
- 5 AFE Data Out**
 - 0 Disabledefault
 - 1 Enable AFE test data output on ATEST pin
- 4 AFE Enable**
 - 0 Enabledefault
 - 1 Disable
- 3 INT Clear**..... default = 1
During the Interrupt Service Routine (ISR) this bit-asserted logic 1 clears the INT output without affecting the contents of the Interrupt Status Register. The device will stop monitoring and resume after clearing this bit.
- 2 Reserved** always reads 0
- 1 INT Output**
 - 0 Disabledefault
 - 1 Enable
- 0 Start** default = 0
 - 0 Put chip in standby modedefault
 - 1 Enable startup of hardware monitoring
 At startup, limit checking functions and scanning begins. Note: Set all HIGH and LOW LIMITS into the LANDesk Configuration Manager ASIC prior to turning on this bit.

Caution: The outputs of the Interrupt pins will not be cleared if the user writes a zero to this location after an interrupt has occurred (see “INT Clear” bit).

Offset 41 – Interrupt Status 1..... RO

- 7 FAN2 Error (FANIN1)** default = 0
A one indicates that a fan count limit has been exceeded.
- 6 FAN1 Error (FANIN0)** default = 0
A one indicates that a fan count limit has been exceeded.
- 5 Reserved** always reads 0
- 4 Temp1 Error (Thermal IN0)** default = 0
Low Hot Temperature limit has been exceeded. Only ‘Default Interrupt’ and ‘One-Time Interrupt’ modes are supported. The mode is set by bit 0 and 1 of the Temperature Resolution Register (for Intel type thermal diode).
- 3 +5V Error (UCH4)**..... default = 0
A one indicates a High or Low limit has been exceeded. (also CH5 of AFE).
- 2 +3.3V Error (Internal VDD)** default = 0
A one indicates a High or Low limit has been exceeded. (also CH7 of AFE).
- 1 VCCP Error (UCH3)** default = 0
A one indicates a High or Low limit has been exceeded. (also CH4 of AFE).
- 0 +2.5V Error (UCH2)**..... default = 0
A one indicates a High or Low limit has been exceeded. (also CH3 of AFE).

Offset 42 – Interrupt Status 2..... RO

- 7 Temp3 Error (THERMAL IN2)** default = 0
Reserved for Internal thermal diode.
- 6-5 Reserved** always reads 0
- 4 Chassis Error (CHASSIS IN)**..... default = 0
A one indicates Chassis Intrusion has gone high.
- 3 Temp2 Error (UCH1 or THERMAL IN1)**...def = 0
A one indicates a High or Low limit has been exceeded. (also for CH2 of AFE).
- 2 Reserved** always reads 0
- 1 –12V / VCCP2 Error (AIN5)**..... default = 0
Reserved
- 0 +12V Error (UCH5)**..... default = 0
A one indicates a High or Low limit has been exceeded.

Note: Any time the Status Register is read, the conditions (in other words, Register) that are read are automatically reset. In the case of voltage priority indication, if two or more voltages were out of limits, then another indication would automatically be generated if it were not handled during the ISR. In the Control Register, the errant voltage may be disabled until the operator has time to clear the errant condition or set the limit higher or lower.

Offset 43 – Interrupt Mask 1RW

- 7 **FAN2** default = 0
A one disables the corresponding interrupt status bit for the INT interrupt.
- 6 **FAN1** default = 0
A one disables the corresponding interrupt status bit for the INT interrupt.
- 5 **Over Temp 1(Intel Thermal TIN0)** default = 0
A one disables the Temp1 as input source to activate Over Temperature (OVTEMP#) indication. (This bit is independent of any interrupt status bit).
- 4 **Temp1 (TIN0)** default = 0
A one disables the corresponding interrupt status bit for the INT interrupt (for Intel type thermal diode).
- 3 **+5V (UCH4)**..... default = 0
A one disables the corresponding interrupt status bit for the INT interrupt.
- 2 **+3.3V (Internal VDD)**..... default = 0
A one disables the corresponding interrupt status bit for the INT interrupt.
- 1 **+VCCP (UCH3)** default = 0
A one disables the corresponding interrupt status bit for the INT interrupt.
- 0 **+2.5V (UCH2)**..... default = 0
A one disables the corresponding interrupt status bit for the INT interrupt.

Offset 44 – Interrupt Mask 2RW

- 7-6 **Reserved** always reads 0
- 5 **Over Temp2 (UCH1 & TIN1)**..... default = 0
A one disables Temp2 as an input source to activate Over Temperature (OVTEMP#) indication. (This bit is independent of any interrupt status bit).
- 4 **Chs_sec (Chassis Intrusion)** default = 0
A one disables the corresponding interrupt status bit for the INT interrupt.
- 3 **Temp2 (UCH1 & TIN1)**..... default = 0
A one disables the corresponding interrupt status bit for the INT interrupt.
- 2-1 **Reserved** always reads 0
- 0 **+12V (UCH5)** default = 0
A one disables the corresponding interrupt status bit for the INT interrupt.

Offset 45 – VID (00h) RO

- 7 **Over Temperature**
0 OVTEMP# output active (low)
1 OVTEMP# output inactive (high)
- 6 **Over Voltage**
0 OVOLT output inactive (low)
1 OVOLT output active (high)
- 5 **Over Fan**
0 OVFAN output inactive (low)
1 OVFAN output active (high)
- 4-0 **VID[4-0]**
These bits read the state of the Voltage ID readouts from the CPU.

Offset 46 – Over Voltage & Over Fan Control (FFh) .. RW

- 7 **Reserved** always reads 1
- 6 **Over FAN of FAN2** default = 1
A one disables FAN2 as an input source to activate the Over FAN (OVFAN) indication. (This bit is independent of any interrupt status bit).
- 5 **Over FAN of FAN1** default = 1
A one disables FAN1 as an input source to activate the Over FAN (OVFAN) indication. (This bit is independent of any interrupt status bit).
- 4 **Over Voltage of UCH5** default = 1
A one disables UCH5 as an input source to activate the Over Voltage (OVOLT) indication. (This bit is independent of any interrupt status bit).
- 3 **Over Voltage of UCH4**..... default = 1
A one disables UCH4 as an input source to activate the Over Voltage (OVOLT) indication. (This bit is independent of any interrupt status bit).
- 2 **Over Voltage of UCH3**..... default = 1
A one disables UCH3 as an input source to activate the Over Voltage (OVOLT) indication. (This bit is independent of any interrupt status bit).
- 1 **Over Voltage of UCH2**..... default = 1
A one disables UCH2 as an input source to activate the Over Voltage (OVOLT) indication. (This bit is independent of any interrupt status bit).
- 0 **Over Voltage of UCH1**..... default = 1
A one disables UCH1 as an input source to activate the Over Voltage (OVOLT) indication. (This bit is independent of any interrupt status bit)

Offset 47 – Fan Speed Control (25h).....RW

- 7-6 FAN2 RPM Control**
FAN2 Speed Control
 - 00 Divide by 1
 - 01 Divide by 2.....default
 - 10 Divide by 4
 - 11 Divide by 8
- 5-4 FAN1 RPM Control**
FAN1 Speed Control
 - 00 Divide by 1
 - 01 Divide by 2.....default
 - 10 Divide by 4
 - 11 Divide by 8
- 3-0 Reserved** always reads 0

Offset 48 – Interrupt Mask 2 (2Dh).....RW

- 7 SMBus Busy** RO
A one indicates that the Hardware Monitor is busy for a Serial Bus transaction.
- 6-0 SMBus Address** RW
[6:0] = 0101101

Offset 49 –VID4 / Device IDRW

- 7-6 Reserved** always reads 0
- 5-4 Temp2 (UCH1, TIN1)**..... RO
For thermal input 2:10-bit temperature resolution (LSB TEMP2[1:0]).
- 3 BEEP**RW
Beep Output
- 2 Chassis** RO
Chassis active low output 20ms.
- 1 Interrupt** RO
Interrupt active high output.
- 0 AFE Enable** RO
If High Enable AFE operation and Low would be enter to standby mode of AFE.

Offset 4A –Universal Channel Configuration (07h)..... RW

- 7 Reserved** always reads 0
- 6 UCH5** default = 0
Logic 1 enables the Thermal input of Universal Channel 1 (UCH5), Logic 0 for Voltage inputs. (Powerup default = 0).
- 5 UCH4** default = 0
Logic 1 enables the Thermal input of Universal Channel 1 (UCH4), Logic 0 for Voltage inputs. (Powerup default = 0)
- 4 UCH3** default = 0
Logic 1 enables the Thermal input of Universal Channel 1 (UCH3), Logic 0 for Voltage inputs. (Powerup default = 0)
- 3 UCH2** default = 0
Logic 1 enables the Thermal input of Universal Channel 1 (UCH2), Logic 0 for Voltage inputs. (Powerup default = 0)
- 2 UCH1** default = 1
Logic 1 enables the Thermal input of Universal Channel 1 (UCH1), Logic 0 for Voltage inputs. (Powerup default = 1)
- 1-0 Reserved** always reads 0

Offset 4B – Temperature Configuration 1 (15h).....RW

7-6 Temperature 1..... RO
For thermal input 1:10- bit temperature resolution. (LSB temp1 [1:0]).

5-4 Same as Bits 1-0 But For Internal Thermal Input 3
Same as above bit 1 & 0, but for thermal input 3 (Reserved for internal thermal diode). def = 01b

3 Hot Temperature Interrupt mode select Bit 1 of Thermal Input of UCH1..... default = 0
A one on this bit (Bit 1) and a zero on Bit 0 selects the comparator mode. This gives an INT when the temperature exceeds the hot limit. This INT remains active until the temperature goes below the hot limit (no hysteresis). When the INT will become inactive.

2 Hot Temperature Interrupt Mode Select Bit 0 of Thermal Input of UCH1..... default = 1
If Bits 0 and Bits 1 of this register are both zero or one, this selects the default interrupt mode, which gives the user an interrupt if the temperature goes above the hot limit. The interrupt will be cleared once the status register is read, but it will again be generated when the next conversion has completed. It will continue to do so until the temperature goes below the hysteresis limit.

A zero on Bit 1 and a one on Bit 0 selects the one-time interrupt mode that gives the user an indefinite interrupt when it goes above the hot limit. The interrupt will be cleared once the status register is read. Another interrupt will not be generated until the temperature first goes below the hysteresis limit. It will also be cleared if the status register is read.

No more interrupts will be generated until the temperature goes above hot limit again. The corresponding bit will be cleared in the status register every time it is read but may not set again when the next conversion is done.

1 Hot Temperature Interrupt Mode Select Bit 1 of Thermal Input of Intel Type Thermal Diodedef = 0
A one on this bit (Bit 1) and a zero on Bit 0 selects the comparator mode. This gives an INT when the temperature exceeds the hot limit. This INT remains active until the temperature goes below the hot limit (no hysteresis). When the INT will become inactive.

0 Hot Temperature Interrupt Mode Select Bit 0 of Thermal Input of Intel Type Thermal Diodedef = 1
If Bits 0 and Bits 1 of this register are both zero or one, this selects the default interrupt mode, which gives the user an interrupt if the temperature goes above the hot limit. The interrupt will be cleared once the status register is read, but it will again be generated when the next conversion has completed. It will continue to do so until the temperature goes below the hysteresis limit.

A zero on Bit 1 and a one on Bit 0 selects the one-time interrupt mode that gives the user an indefinite interrupt when it goes above the hot limit. The interrupt will be cleared once the status register is read. Another interrupt will not be generated until the temperature first goes below the hysteresis limit. It will also be cleared if the status register is read.

No more interrupts will be generated until the temperature goes above the hot limit again. The corresponding bit will be cleared in the status register every time it is read but may not set again when the next conversion is done.

Offset 4C – Temperature Configuration 2 (55h).....RW

- 7-6 Same as bit 1-0 but for Thermal input of UCH5**
..... default = 00b
Same as above bit 1 & 0, but for Thermal input of UCH5
- 5-4 Same as bit 1-0 but for Thermal input of UCH4**
..... default = 10b
Same as above bit 1 & 0, but for Thermal input of UCH4
- 3 Hot Temperature Interrupt Mode select bit 1 of thermal input of UCH3** default = 0
A one on this bit (Bit 1) and a zero on Bit 0 selects the comparator mode. This gives an INT when the temperature exceeds the hot limit. This INT remains active until the temperature goes below the hot limit (no hysteresis). When the INT will become inactive.
- 2 Hot Temperature Interrupt mode select bit 1 of thermal input of UCH3** default = 0
If Bits 0 and Bits 1 of this register are both zero or one, this selects the default interrupt mode, which gives the user an interrupt if the temperature goes above the hot limit. The interrupt will be cleared once the status register is read, but it will again be generated when the next conversion has completed. It will continue to do so until the temperature goes below the hysteresis limit.
A zero on Bit 1 and a one on Bit 0 selects the one-time interrupt mode that gives the user an indefinite interrupt when it goes above the hot limit. The interrupt will be cleared once the status register is read. Another interrupt will not be generated until the temperature first goes below the hysteresis limit. It will also be cleared if the status register is read.
No more interrupts will be generated until the temperature goes above hot limit again. The corresponding bit will be cleared in the status register every time it is read but may not set again when the next conversion is done.

- 1 Hot Temperature Interrupt mode select Bit 1 of thermal input of UCH2** default = 1
A one on this bit (Bit 1) and a zero on Bit 0 selects the comparator mode. This gives an INT when the temperature exceeds the hot limit. This INT remains active until the temperature goes below the hot limit (no hysteresis). When the INT will become inactive.
- 0 Hot Temperature Interrupt mode select Bit 0 of thermal input of UCH2** default = 0
If Bits 0 and Bits 1 of this register are both zero or one, this selects the default interrupt mode, which gives the user an interrupt if the temperature goes above the hot limit. The interrupt will be cleared once the status register is read, but it will again be generated when the next conversion has completed. It will continue to do so until the temperature goes below the hysteresis limit.
A zero on Bit 1 and a one on Bit 0 selects the one-time interrupt mode that gives the user an indefinite interrupt when it goes above the hot limit. The interrupt will be cleared once the status register is read. Another interrupt will not be generated until the temperature first goes below the hysteresis limit. It will also be cleared if the status register is read.
No more interrupts will be generated until the temperature goes above hot limit again. The corresponding bit will be cleared in the status register every time it is read but may not set again when the next conversion is done.

Offset 4D – Temperature Resolution.....RO

- 7-6 Temp of UCH5**
For thermal input of UCH5: 10-bit temperature resolution (LSB TEMP [1:0]).
- 5-4 Temp of UCH4**
For thermal input of UCH4: 10-bit temperature resolution (LSB TEMP [1:0]).
- 3-2 Temp of UCH3**
For thermal input of UCH3: 10-bit temperature resolution (LSB TEMP [1:0]).
- 1-0 Temp of UCH2**
For thermal input of UCH2: 10-bit temperature resolution (LSB TEMP [1:0]).

Offset 4E – Over Temperature Control (0Fh) RW

- 3 Over Temperature of UCH5** default = 1
A one disables the UCH5 as input source to activate the Over Temperature (OVTEMP_) occurs. (This bit is independent with any interrupt status bit). (Powerup default = 1).
- 2 Over Temperature of UCH4** default = 1
A one disables the UCH4 as input source to activate the Over Temperature (OVTEMP_) occurs. (This bit is independent with any interrupt status bit). (Powerup default = 1).
- 1 Over Temperature of UCH3** default = 1
A one disables the UCH3 as input source to activate the Over Temperature (OVTEMP_) occurs. (This bit is independent with any interrupt status bit). (Powerup default = 1).
- 0 Over Temperature of UCH2** default = 1
A one disables the UCH2 as input source to activate the Over Temperature (OVTEMP_) occurs. (This bit is independent with any interrupt status bit). (Powerup default = 1).

Offset 50 – PWM Clock Selection (00h).....RW

- 7-3 **Reserved** always reads 0
- 2-0 **PWM Clock Selection** default = 000b
 - 000 90K Hz
 - 001 45K Hz
 - 010 22.5K Hz
 - 011 11.25K Hz
 - 100 5.63K Hz
 - 101 2.8K Hz
 - 110 1.4K Hz
 - 111 700 Hz

Offset 51 – PWM Control (00h).....RW

- 7 **Reserved** always reads 0
- 6-4 **PWM 2 Input Selection**
 - 000 External Intel Thermal Sensor.....default
 - 001 Internal Thermal Sensor
 - 010 External UCH1
 - 011 External UCH2
 - 100 External UCH3
 - 101 External UCH4
 - 110 External UCH5
 - 111 External Intel Thermal Sensor
- 3 **Reserved** always reads 0
- 2-0 **PWM 1 Input Selection**
 - 000 External Intel Thermal Sensor.....default
 - 001 Internal Thermal Sensor
 - 010 External UCH1
 - 011 External UCH2
 - 100 External UCH3
 - 101 External UCH4
 - 110 External UCH5
 - 111 External Intel Thermal Sensor

Offset 52 –PWM Full Speed Temperature (00h).....RW

- 7-0 **PWM Full Speed Temperature Value**..... def= 00h

Offset 53 – PWM High Speed Temperature (00h)RW

- 7-0 **PWM High Speed Temperature Value** def= 00h

Offset 54 – PWM Low Speed Temperature (00h).....RW

- 7-0 **PWM Low Speed Temperature Value** def= 00h

Offset 55 – PWM Fan Off Temperature (00h)RW

- 7-0 **PWM Fan Off Temperature Value** def= 00h

Offset 56 – PWM 1 High Speed Duty Cycle (FFh) RW

Offset 57 – PWM 1 Low Speed Duty Cycle (FFh)..... RW

Offset 58 – PWM 2 High Speed Duty Cycle (FFh)..... RW

Offset 59 – PWM 2 Low Speed Duty Cycle (FFh)..... RW

Note: For these registers 00h = 0% duty cycle, FFh = 100%

Offset 5C – BEEP Event Enable RW

- 7-3 **Reserved** always reads 0
- 2 **Temperature Beep**
 - 0 Disable..... default
 - 1 Enable (Beep when the temperature value exceeds the limit)
- 1 **Voltage Beep**
 - 0 Disable..... default
 - 1 Enable (Beep when the voltage value exceeds the limit)
- 0 **Fan Beep**
 - 0 Disable..... default
 - 1 Enable (Beep when the fan counter value exceeds the limit)

Offset 5D – Fan Beep Frequency Divisor RW

- 7-4 **Fan Event Tone Divisor** default = 0
Tone = 8Hz / (bits [7:4] + 1)
- 3-0 **Fan Event Frequency Divisor**..... default = 0
Frequency = 8Kz / (bits [3:0] +1)

Offset 5E – Voltage Beep Frequency Divisor RW

- 7-4 **Voltage Event Tone Divisor**..... default = 0
Tone = 8Hz / (bits [7:4] + 1)
- 3-0 **Voltage Event Frequency Divisor** default = 0
Frequency = 8Kz / (bits [3:0] +1)

Offset 5F – Temperature Beep Frequency Divisor..... RW

- 7-4 **Temperature Event Tone Divisor** default = 0
Tone = 8Hz / (bits [7:4] + 1)
- 3-0 **Temperature Event Frequency Divisor** .. default = 0
Frequency = 8Kz / (bits [3:0] +1)

Offset 60 – PWM1 Current Duty Cycle..... RW

Offset 61 – PWM2 Current Duty Cycle..... RW

IrDA (VFIR) Host Controller I/O Registers

These registers are normally accessed at I/O port addresses starting at E800h (see LDN C Rx61-60 for the VFIR Controller I/O Port Base setting).

Offset 10 – Infrared Configuration Low 0.....RW

- 7 CRC Length**
 - 0 32-bit CRCdefault
 - 1 16-bit CRC
- 6 FIR Mode**
 - 0 Disabledefault
 - 1 Enable
- 5 MIR Mode**
 - 0 Disabledefault
 - 1 Enable
- 4 SIR Mode**
 - 0 Disabledefault
 - 1 Enable
- 3 SIR Configuration Enable**
 - 0 Disabledefault
 - 1 Enables SIR Byte FILTER on the receiver when SIR mode bit is set
- 2 SIR Test**
 - 0 Disabledefault
 - 1 Enables SIR FILTER to be used when not in SIR mode
- 1 Invert Transmit LED**
 - 0 Do not invertdefault
 - 1 Invert TX LED (TXD pin) output
- 0 Invert Receive LED**
 - 0 Do not invertdefault
 - 1 Invert RX LED (FIRRXD and SIRRXD) input

Offset 11 – Infrared Configuration High 0 RW

- 7-6 Reserved**..... always reads 0
- 5 VFIR Mode (16 Mbit)**
 - 0 Disable..... default
 - 1 Enable
- 4 Transmit Enable**
 - 0 Disable..... default
 - 1 Enables the transmitter at the physical layer
- 3 Receive Enable**
 - 0 Disable..... default
 - 1 Enables the receiver at the physical layer (The receiver will not be enabled if ENTX is on and loop back is not active).
- 2 Memory Sequencer Enable**
 - 0 Disable..... default
 - 1 Enable the memory sequencer to allow memory access through by ISA DMA controller
- 1 Receive Small / Runtime Packets (<4 Bytes)**
 - 0 Disable..... default
 - 1 Enable (used for SIR mode only)
- 0 FIFO Size**
 - 0 64 bytes of FIFO level for each of Rx and Tx default
 - 1 32 bytes of FIFO level for each of Rx and Tx

Offset 12 – Infrared SIR BOF (C0h).....RW

7-0 **BOF Flag**.....default = C0h
Value used as Begin-of-Flag for SIR format.

Offset 13 – Infrared SIR EOF (C1h).....RW

7-0 **EOF Flag**.....default = C1h
Value used as of End-of-Flag for SIR format.

Offset 14 – Infrared Status High 0RO

7-1 **Reserved**..... always reads 0
0 **VFIR On**..... default = 0
'1' indicates a valid VFIR configuration

Offset 15 – Infrared Status and Control 0 (00h)RW

7 **IR Enable**RW
0 Disabledefault
1 Enables both circuits of physical layer interface and clock generation

6 **Configuration Error** RO
When set to '1', indicates an error occurs by more than one mode was selected. (Powerup Default=0).

5 **FIR On** RO
When set to '1', indicates a valid FIR configuration. (Powerup Default=0).

4 **MIR On** RO
When set to '1', indicates a valid MIR configuration. (Powerup Default=0).

3 **SIR On** RO
When set to '1', indicates a valid SIR configuration. (Powerup Default=0).

2 **Transmit** RO
0 Disableddefault
1 Enabled at the physical layer

1 **Receive** RO
0 Disableddefault
1 Enabled at the physical layer

0 **CRC 16 / 32** RO
0 32-bit CRC generation
1 16-bit CRC generation

Offset 16 – Infrared Status Low 1 (00h)..... RO

7-5 **SIR/MIR Pulse Width [2:0]** (see Table 7 below) RO
4-0 **Preamble [4:0]**RO
Number of Preamble bytes to send in MIR and FIR mode. For MIR this is the number of start flags plus 1, for FIR it is the number of preamble bytes plus 1. (i.e., 0 means 1 byte). (see Table 7 below).

Offset 17 – Infrared Status High 1 (00h)..... RO

7-2 **Data Baud Rate [5:0]** (see Table 7 below).....RO
1-0 **SIR/MIR Pulse Width [4:3]** (see Table 7 below) RO

Offset 18 – Infrared Configuration Low 1 (00h).. RW

7-5 **SIR/MIR Pulse Width [2:0]** (see Table 7 below)
..... default = 0
4-0 **Preamble [4:0]** (see Table 7 below)..... default = 0
Number of Preamble bytes to send in MIR and FIR mode. For MIR this is the number of start flags plus 1, for FIR it is the number of preamble bytes plus 1. (ie, 0 means 1 byte).

Offset 19 – Infrared Configuration High 1 (00h)..... RW

7-2 **Data Baud Rate [5:0]** (see Table 7 below)
..... default = 0
1-0 **SIR/MIR Pulse Width [4:3]** (see Table 7 below)
..... default = 0

Table 7. IR Operational Modes

Mode	Baud Rate	Pulse Width			Preamble
		Min	Nom	Max	
SIR (2400)	47d	0d	12d	12d	don't care
SIR (9600)	11d	0d	12d	12d	don't care
SIR (19200)	5d	1d	12d	12d	don't care
SIR (38400)	2d	3d	12d	14d	don't care
SIR (57600)	1d	5d	12d	16d	don't care
SIR (115200)	0d	11d	12d	20d	don't care
MIR	0	8d			1
FIR	0	don't care			14d (0Eh)

Offset 1A – Infrared Configuration Low 2 (00h)..... RW

7-0 **Max Allowable Receive Packet [7:0]** def = 0
This is used to indicate the maximum length in bytes of a receive packet (see Rx1B below for bits 12-8).

Offset 1B – Infrared Configuration High 2 (00h)..... RW

7-5 **Reserved** always reads 0
4-0 **Max Allowable Receive Packet [12:8]** def = 0
Used to indicate the maximum length in bytes of a receive packet (see Rx1A above for bits 7-0).

Offset 1E – Infrared Configuration 3 (00h).....RW

- 7-6 Filter Select**
 - 00 Highest filterdefault
 - 01 Medium high filter
 - 10 Medium low filter
 - 11 Lowest filter
- 5 FIR Adjacent Pulse Width Packet Circuit**
 - 0 Enabledefault
 - 1 Disable
- 4 FIR Pulse Width Adjustment.**
 - 0 Enabledefault
 - 1 Disable
- 3-2 Reserved** always reads 0
- 1 Number of Receive Pins**
One receive pin instead of two.
 - 0 2 receiver paths. (use IRRX for FIR and IRRX1 for SIR).....
 - 1 1 receiver (i.e., use IRRX for FIR and SIR)
- 0 Invert RX Mode**
When one receive pin is configured, this bit defines polarity for the mode pin to the Optical module.
 - 0 Slow speed is chosen by a logic ‘0’.....default
 - 1 Slow speed is chosen by a logic ‘1’

Offset 20 – Host Control..... RW

- 7 Interrupt Enable**
 - 0 Disable..... default
 - 1 Enables all FIR Controller interrupts
- 6 Transmit Start** default = 0
Start execution of transmit. Logic 1 initiates the transmitter logic of controller to execute the transmitting mode of IR programmed in the infrared configuration registers and also need to setup DMA and all necessary registers prior to writing a 1 to this bit position. Writing a 0 has no effect. This bit always reads 0. The Host_Busy bit can be used to identify when the IR host controller has finished executing the Transmission.
- 5 Receive Start**..... default = 0
Start receive execution. Logic 1 initiates the default controller receiver logic to execute the receiving mode of IR programmed in the infrared configuration registers. DMA and all necessary registers need to be set up prior to writing a 1 to this bit position. Writing a 0 has no effect. This bit always reads 0. The Host_Busy bit can be used to identify when the IR host controller has finished executing the reception.
- 4 Clear Rx Interrupt**
 - 0 Don’t clear default
 - 1 Clear Rx Interrupt output
- 3-0 Reserved**..... always reads 0

Offset 21 – Host Status (00h).....RO

- 7 **Reserved** always reads 0
- 6 **Timer Interrupt**..... RO
‘1’ indicates that a timer interrupt is pending.
- 5 **Tx Interrupt** RO
‘1’ indicates that a transmitter interrupt is pending.
- 4 **Rx Interrupt** RO
‘1’ indicates that a receiver interrupt is pending. The following conditions clear the Rx Interrupt condition:
 - Reading the Rx Ring Packet Counter Low Register
 - Issuing a Reset Rx Special Condition Interrupt command
 - Hardware Reset
 - Software Reset
- 3-1 **Interrupt Identification [2:0]** RO
This 3-bit identification code provides an alternative method for identifying the interrupt source by indicating the interrupt type and priority level.

<u>Interrupt Type</u>	<u>Priority</u>
0xx -reserved-	n/a
100 Rx Special Condition	Highest
– FIFO Overrun	
– CRC Error	
– End of Packet (EOF)	
– Phy Error	
– Max Length	
– Bad SIR	
101 Rx Data Available	Second
110 Tx Buffer Empty	Third
111 Tx Special Condition	Fourth
– FIFO Underrun	
– EOM	
– Early EOM	
- 0 **Host Busy** RO
 - 0 IR controller host interface is not processing a transaction.
 - 1 IR controller host interface is in the process of completing a transaction (any transmit or receive).

Offset 22 – Miscellaneous Control RW

- 7 **Transmit DMA Enable**
 - 0 Disable..... default
 - 1 Enable DREQ1 (if dual DMA channel is selected) as a transmit DMA channel
- 6 **Receive DMA Enable**
 - 0 Disable the receive DMA channel (but DREQ0 is used also for transmit if both of bits of single DMA channel DREQ0 and Transmit DMA Enable are set) default
 - 1 Enable DREQ0 as a receive DMA channel (DREQ0 is also used for the transmit DMA channel if a single DMA channel is selected)
- 5 **Swap DMA Channel**
 - 0 Disable..... default
 - 1 Enable swap of DREQ0 and DREQ1
- 4 **Internal Loopback**
 - 0 Disable..... default
 - 1 Enable internal loopback at the physical layer
- 3 **Enable Transmit on Loop**
 - 0 Disable..... default
 - 1 Enable transmission to LED when internal loopback is enabled
- 2-0 **Reserved** always reads 0

Offset 23 – Transmit Control 1 (00h)..... RW

- 7 **Reserved** always reads 0
- 6 **Transmit FIFO Ready Interrupt**
 - 0 Disable..... default
 - 1 Enable TxFIFO Ready interrupt (when TXFIFO reaches its threshold level).
- 5 **Transmit FIFO Underrun/EOM Interrupt Enable**
 - 0 Disable..... default
 - 1 Enable TxFIFO Underrun and EOM interrupts.
- 4-3 **Transmit FIFO Level**
An interrupt occurs when bit-6 (Transmit FIFO Ready Interrupt) is set and the Transmit FIFO level is below the trigger level per the following setting (settings depend on the FIFO size):
 - 00 FIFO Full..... default
 - 01 FIFO 3/4 Full
 - 10 FIFO 1/2 Full
 - 11 FIFO 1/4 Full
- 2-0 **Reserved** always reads 0

Offset 24 – Tx Control 2 (40h)RW

- 7 Force Underrun**
 - 0 Disabledefault
 - 1 Enable an underrun on this packet for testing (for an underrun occur, the Tx count should be greater than 18 bytes)
- 6 Transmit CRC**
 - 0 Setting for SIR mode or bridging application where CRC should not be generated by hardware
 - 1 Enable Tx CRC for synchronous packets.... **def**
- 5 Bad CRC**
 - 0 Disabledefault
 - 1 Send out inverted CRC or bad CRC (used to test the receiver CRC verification hardware)
- 4 Need Pulse**
 - 0 Disabledefault
 - 1 Transmit an indication pulse after this packet has been transmitted
- 3 Request To Clear Enable Transmit**
 - 0 Disabledefault
 - 1 Enables the hardware to clear the ENTX bit (Rx10[5]) after this packet is completed. Should be set on a least packet of a transmit sequence.
- 2-0 Early EOM Interrupt Level..... default = 000b**
 Specifies the number of bytes that must remain in Tx Byte Count before an Early EOM interrupt is generated. The reason for having an interrupt occur before transmission has actually completed is to allow enough time for the software to enter the proper interrupt handler routine, turn the DMA channel around for reception (Single DMA mode), or prepare for another back-to-back transmission. Once in the interrupt handler routine, the software can poll the EOM bit in TxStatus Register to determine exactly when the transmission ends.
 - 000 Interrupt by EOM.....default
 - 001 EOM intr occurs when remaining count = 16
 - 010 EOM intr occurs when remaining count = 32
 - 011 EOM intr occurs when remaining count = 64
 - 100 EOM intr occurs when remaining count = 128
 - 101 EOM intr occurs when remaining count = 256
 - 110 EOM intr occurs when remaining count = 512
 - 111 EOM intr occurs when remaining count = 1024

Offset 25 – Tx Status RO

- 7-4 Reserved..... always reads 0**
- 3 TxFIFO Underrun..... default = 0**
 '1' indicates that the TxFIFO ran out of data before the transmitter could finish transmitting all the data (i.e., TxFIFO is empty, and the Tx Byte Count value is greater than zero). This bit must be reset by an explicit FIFO Underrun/EOM Latch command.
- 2 EOM (End of Message)..... default = 0**
 '1' indicates transmission completed successfully. The EOM interrupt occurs immediately after the CRC and ending flag have been transmitted. The EOM bit would be clear by a reset FIFO Underrun/EOM Latch command from the Reset Command Register.
- 1 TxFIFO Ready..... default = 0**
 '1' indicates that the Transmit FIFO is ready for more data transfers. When the En_TXFIFO_Ready Int bit (Bit 6 of the 'TxControl 1' Register) is set, an interrupt is generated whenever this condition becomes true.
- 0 Early End of Message (EOM)..... default = 0**
 '1' indicates that the Tx Byte Count has reached the count level set by the Early EOM Interrupt Level (Bits 2:0 in 'TxControl 2' Register). This bit is cleared by reading TxStatus.

Offset 26 – Rx Control (40h).....RW

- 7-6 RxFIFO Level**
An interrupt occurs when bit-1 (Rx FIFO Ready Interrupt) is set and the Receive FIFO level reaches the following setting (settings depend on FIFO Size bits 1-0):
- 00 Full leveldefault
 - 01 1/4
 - 10 1/2
 - 11 3/4
- 5-4 Rx Address Mode [1:0]**
Specifies the type of address filtering to apply for determining which receive packets to accept.
- 00 All packets are received with no filter applieddefault
 - 01 Packets with addresses that match the address aetting in bits 7-1 of the Packet Address register will be received
 - 10 Packets with addresses that match the address aetting in bits 7-4 of the Packet Address register will be received
 - 11 Packets with addresses that match the address aetting in bits 7-0 of the Packet Address register will be received
- 3-2 Reserved** always reads 0
- 1 Rx FIFO Ready Interrupt**
- 0 Disabledefault
 - 1 Enable
- 0 Rx Special Condition Interrupt**
- 0 Disabledefault
 - 1 Enable the following receive special condition interrupts:
 - Overrun
 - CRC Error
 - End of Packet (EOF)
 - PHY Error: The physical layer detected an encoding error.
 - Max Length: The maximum length packet was encountered.
 - SIR Bad

Offset 27 – Rx Status..... RO

- 7 PHY Error** default = 0
‘1’ indicates the physical layer has detected an error encoding. This bit is automatically cleared upon detection of the ending/stop flag of the next incoming packet.
- 6 CRC Error** default = 0
‘1’ indicates that a CRC error occurred. The CRC is checked against known constants for either 16 or 32 bits depending on the length of the CRC chosen in the IRCONFIG0 register (Rx10h). Valid for VFIR, MIR, and FIR modes only. This bit is automatically cleared upon detection of the ending/stop flag of the next incoming packet.
- 5 FIFO Overrun Interrupt** default = 0
‘1’ indicates that the RxFIFO overflowed. This bit is cleared by a reset Rx Special Condition Interrupt command from the Reset Command Register.
- 4 EOF (End of Packet)** default = 0
‘1’ indicates that a packet has completed reception. This bit is automatically cleared upon starting of the next packet.
- 3 Rx Data Available**
- 0 RxFIFO is empty default
 - 1 RxFIFO is not empty (i.e., the FIFO contains receive data).
- This bit doesn’t cause an interrupt.
- 2 Reserved** always reads 0
- 1 Rx Max Length** default = 0
‘1’ indicates the maximum length packet was encountered. For SIR this means the packet was closed and another will be open without any data being truncated. In other modes once the maximum length is hit, no other data will be received. This bit is automatically cleared upon starting the next packet.
- 0 SIR Bad** default = 0
If the SIR filter is on and this bit is ‘1’, it indicates that a begin flag is seen followed by valid data and then followed by another begin flag (without an end flag). This bit is automatically cleared upon starting of the next packet.

Offset 28 – Reset Command (00h)RW

- 7-4 Reset Command [3:0]WO**
Used to send a reset signal to the appropriate hardware in order to clear a particular status condition, a counter, or general reset. These bits are self-clearing (i.e., the programmer does not need to reset the Reset Command bit value to 0000).
0000 No reset command.....default
0001 -reserved-
0010 Reset Rx FIFO Pointer
0011 Reset Rx Special Condition Interrupt
0100 Reset Rx Ring Packet Pointer
0101 Reset FIFO Underrun / EOM Latch
0110 Reset Tx FIFO Pointer
0111 Software Reset
1xxx -reserved-
- 3-0 Reserved always reads 0**

Offset 29 – Packet Address.....RW

- 7-0 Rx Packet Address default = 0**
Specifies the address value that must be contained in the address field of incoming packets.
See also the Rx Address Mode setting (BITS 5-4 in RxControl Register) in the ‘Rx Control’ Register.

Offset 2A – Rx Byte Count LowRO

- 7-0 Rx Byte Count [7:0] default = 0**
Provides a running count (low-order value) of the number of bytes of data being received. This information is useful for checking if a reception is in progress. It should not be used to determine packet length (RFP would be used to do this).

Offset 2B – Rx Byte Count High (00h).....RO

- 7-5 Reserved always reads 0**
- 4-0 Rx Byte Count [12:8]**
Provides a running count (high-order value) of the number of bytes of data being received. This information is useful for checking if a reception is in progress. It should not be used to determine packet length (RFP would be used to do this).

Offset 2C – Rx Ring Packet Pointer Low RO

- 7-0 Ring Frame Pointer [7:0]..... default = 0**
Used in back-to-back packet reception to provide the end-of-packet pointer value (i.e., a pointer to the last byte of a frame received in the receive buffer).
The order of byte access to the Ring Packet Pointer is critical for obtaining a valid pointer value. The programmer must ensure that the low byte is read first, followed by the high byte.

Offset 2D – Rx Ring Packet Pointer High (00h) RO

- 7 Reserved always reads 0**
- 6-0 Rx Frame Pointer [14:8]**
Used in back-to-back packet reception to provide the end-of-packet pointer value (i.e., a pointer to the last byte of a frame received in the receive buffer).
The order of byte access to the Ring Packet Pointer is critical for obtaining a valid pointer value. The programmer must ensure that the low byte is read first, followed by the high byte.

Offset 2E – Tx Byte Count Low RW

- 7-0 Tx Byte Count [7:0]..... default = 0**
Provides a running count of the number of bytes of remaining to be transmitted. Before enabling transmission, software loads this register with the low-order byte length of the data packet. Each time Tx FIFO is written to, the value of this counter decrements by 1. When the counter reaches zero, the transmitter ceases to make DMA requests. Transmission continues until Tx FIFO is depleted.

Offset 2F – Tx Byte Count High..... RW

- 7-4 Reserved always reads 0**
- 3-0 Tx Byte Count [11:8]..... default = 0000b**
Provides a running count of the number of bytes remaining to be transmitted. Before enabling transmission, software loads this register with the high-order byte length of the data packet. Each time the Tx FIFO is written to, the value of this counter decrements by 1. When the counter reaches zero, the transmitter ceases to make DMA requests. Transmission continues until the Tx FIFO is depleted.

Offset 32 – General Purpose TimerRW

- 7-0 Timer** default = 0
The current value of the up-counter is returned when host reading this register. The running value is reset to '0' if host write to this register.
The up-counter has a count time of 125us per increment. The counter will stop incrementing when it reaches the programmed target value.

Offset 33 – Infrared ConfigurationRW

- 7 GPIO0 Source** default = 0
 - 0 GPIO0 source depends on the IrDA mode select (Rx10[6:4]) and Infrared Configuration Register 3 (Rx1Eh) bits 1-0.
 - 1 Select the GPIO0 source as IRRX1
- 6-2 Reserved** always reads 0
- 1 Enable Timer Interrupt**
 - 0 Disable default
 - 1 Enable
- 0 Timer Interrupt Pending.....WC**
 - 0 No timer interrupt pending..... default
 - 1 Timer interrupt pending

A timer interrupt occurs when the value in the General Purpose Timer register reaches the programmed target value. To clear the interrupt, software writes a 1 to this bit.

Offset 34 – Infrared Transceiver Control Low RW

- 7 GPIO 0** default = 0
For data input/output and from/to IRRX1 pin. This bit is controlled by Rx33[7].
- 6 GPIO 1** default = 0
For data input/output and from/to ITMOFF pin.
- 5-4 Reserved** always reads 0
- 3 IRRX Pin** **RO**
Used for reading the state of the IRRX pin
- 2-1 Reserved** always reads 0
- 0 IRTX Force**
 - 0 IRTX pin deasserted default
 - 1 IRTX pin asserted

Offset 35 – Infrared Transceiver Control High RW

- 7 Drive IRRX1**
This bit controls and reads the IRRX1 pin.
 - 0 Disable..... default
 - 1 Enables mode programming of the Infrared Transceiver
- 6 Drive ITMOFF**
 - 0 Disable..... default
 - 1 Enables the SCLK pin as an interface signal for a device that meets revision 1.0 of the Transceiver Control Serial Interface specification.
- 5-0 Reserved** always reads 0

ELECTRICAL SPECIFICATIONS

Absolute Maximum Ratings

Symbol	Parameter	Min	Max	Unit	Comment
T _{STG}	Storage temperature	-55	125	°C	
T _C	Case operating temperature	0	85	°C	
V _{CC}	Power supply voltages	-0.5	4.0	Volts	
V _I	Input voltage	-0.5	5.5	Volts	
V _O	Output voltage at any output	-0.5	V _{CC} + 0.5	Volts	
V _{ESD}	Electrostatic discharge		2	kV	Human Body Model

Note: Stress above the conditions listed may cause permanent damage to the device. Functional operation of this device should be restricted to the conditions described under operating conditions.

DC Characteristics

T_C = 0-85°C, V_{CC} = V_{CCA} = 3.3V±5%, GND = 0V

Symbol	Parameter	Min	Max	Unit	Condition
V _{IL}	Input Low Voltage	-0.50	0.8	Volts	
V _{IH}	Input High Voltage	2.0	V _{CC} + 0.5	Volts	
V _{OL}	Output Low Voltage	-	0.45	Volts	I _{OL} =4.0mA
V _{OH}	Output High Voltage	2.4	-	Volts	I _{OH} =-1.0mA
I _{IL}	Input Leakage Current	-	± 10	uA	0<V _{IN} <V _{CC}
I _{OZ}	Tristate Leakage Current	-	± 20	uA	0.45<V _{OUT} <V _{CC}

Power Specifications

T_C = 0-85°C, V_{CC} = 3.3V±5%, GND = 0V

Symbol	Parameter	Typ	Max	Unit	Condition
I _{CC-PD}	Power Supply Current – VCC	63.37	63.55	mA	Power down or suspend
I _{CC}	Power Supply Current – VCC	71.67	75.7	mA	Normal Operation

MECHANICAL SPECIFICATIONS

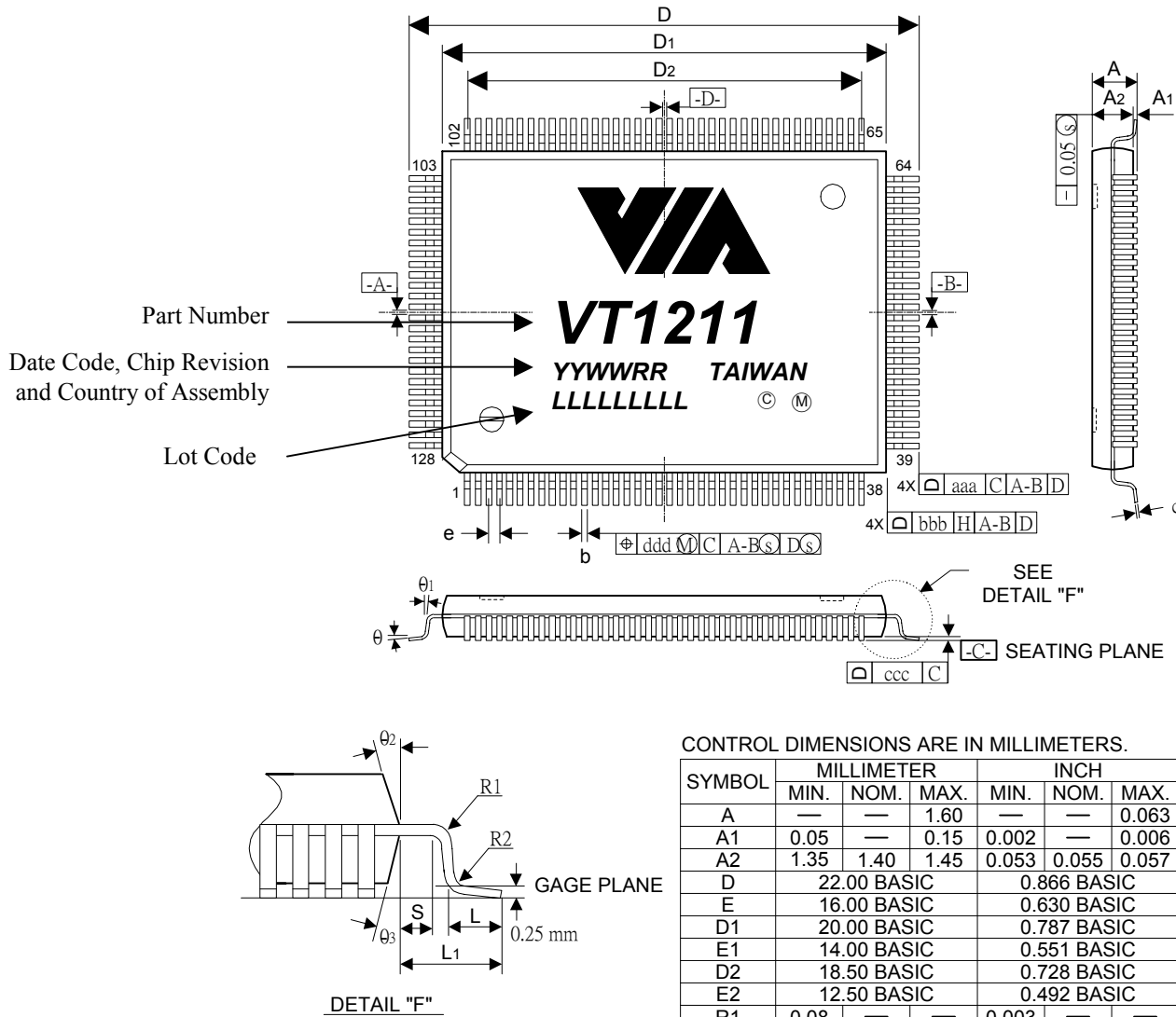

CONTROL DIMENSIONS ARE IN MILLIMETERS.

SYMBOL	MILLIMETER			INCH		
	MIN.	NOM.	MAX.	MIN.	NOM.	MAX.
A	—	—	1.60	—	—	0.063
A1	0.05	—	0.15	0.002	—	0.006
A2	1.35	1.40	1.45	0.053	0.055	0.057
D	22.00 BASIC			0.866 BASIC		
E	16.00 BASIC			0.630 BASIC		
D1	20.00 BASIC			0.787 BASIC		
E1	14.00 BASIC			0.551 BASIC		
D2	18.50 BASIC			0.728 BASIC		
E2	12.50 BASIC			0.492 BASIC		
R1	0.08	—	—	0.003	—	—
R2	0.08	—	0.20	0.003	—	0.008
θ	0	3.5	7	0	3.5	7
θ1	0	—	—	0	—	—
θ2	11	12	13	11	12	13
θ3	11	12	13	11	12	13
c	0.09	—	0.20	0.004	—	0.008
L	0.45	0.60	0.75	0.018	0.024	0.030
L1	1.00 REF			0.039 REF		
S	0.20	—	—	0.008	—	—
b	0.17	0.20	0.27	0.007	0.008	0.011
e	0.50 BASIC			0.020 BASIC		
TOLERANCES OF FORM AND POSITION						
aaa	0.20			0.008		
bbb	0.20			0.008		
ccc	0.08			0.003		
ddd	0.08			0.003		

NOTES :

- DIMENSIONS D1 AND E1 DO NOT INCLUDE MOLD PROTRUSION. ALLOWABLE PROTRUSION IS 0.25 mm PER SIDE. D1 AND E1 ARE MAXIMUM PLASTIC BODY SIZE DIMENSIONS INCLUDING MOLD MISMATCH.
- DIMENSION b DOES NOT INCLUDE DAMBAR PROTRUSION. ALLOWABLE DAMBAR PROTRUSION SHALL NOT CAUSE THE LEAD WIDTH TO EXCEED THE MAXIMUM b DIMENSION BY MORE THAN 0.08mm. DAMBAR CAN NOT BE LOCATED ON THE LOWER RADIUS OR THE FOOT. MINIMUM SPACE BETWEEN PROTRUSION AND AN ADJACENT LEAD IS 0.07mm.

Figure 4. 128-Pin LQFP – Low-Profile Quad Flat Pack

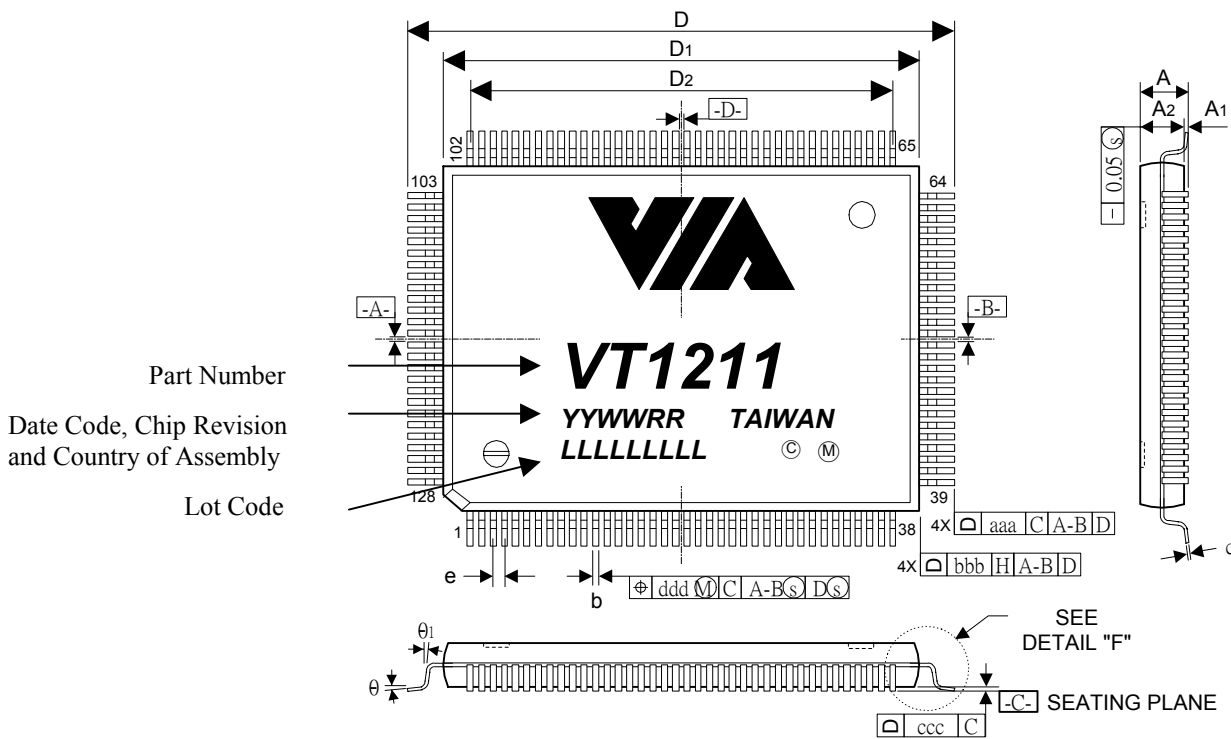

Part Number
Date Code, Chip Revision
and Country of Assembly
Lot Code

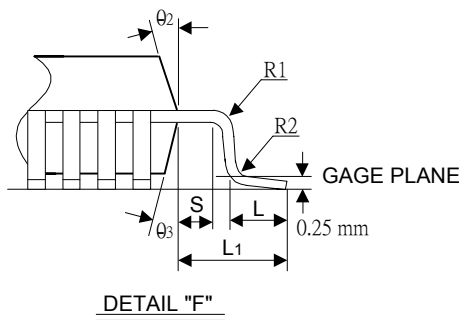

DETAIL "F"

NOTES :

- DIMENSIONS D1 AND E1 DO NOT INCLUDE MOLD PROTRUSION. ALLOWABLE PROTRUSION IS 0.25 mm PER SIDE. D1 AND E1 ARE MAXIMUM PLASTIC BODY SIZE DIMENSIONS INCLUDING MOLD MISMATCH.
- DIMENSION b DOES NOT INCLUDE DAMBAR PROTRUSION. ALLOWABLE DAMBAR PROTRUSION SHALL NOT CAUSE THE LEAD WIDTH TO EXCEED THE MAXIMUM b DIMENSION BY MORE THAN 0.08mm. DAMBAR CAN NOT BE LOCATED ON THE LOWER RADIUS OR THE FOOT. MINIMUM SPACE BETWEEN PROTRUSION AND AN ADJACENT LEAD IS 0.07mm.

CONTROL DIMENSIONS ARE IN MILLIMETERS.

SYMBOL	MILLIMETER			INCH		
	MIN.	NOM.	MAX.	MIN.	NOM.	MAX.
A	—	—	3.40	—	—	0.134
A1	0.25	—	—	0.010	—	—
A2	2.50	2.72	2.90	0.098	0.107	0.114
D	23.20 BASIC			0.913 BASIC		
E	17.20 BASIC			0.677 BASIC		
D1	20.00 BASIC			0.787 BASIC		
E1	14.00 BASIC			0.551 BASIC		
D2	18.50 BASIC			0.728 BASIC		
E2	12.50 BASIC			0.492 BASIC		
R1	0.13	—	0.30	0.005	—	0.012
R2	0.13	—	—	0.005	—	—
theta	0	—	7	0	—	7
theta_1	0	—	—	0	—	—
theta_2	15 REF			15 REF		
theta_3	15 REF			15 REF		
c	0.11	0.15	0.23	0.004	0.006	0.009
L	0.73	0.88	1.03	0.029	0.035	0.041
L1	1.60 REF			0.063 REF		
S	0.20	—	—	0.008	—	—
b	0.17	0.20	0.27	0.007	0.008	0.011
e	0.50 BASIC			0.020 BASIC		
TOLERANCES OF FORM AND POSITION						
aaa	0.20			0.008		
bbb	0.20			0.008		
ccc	0.08			0.003		
ddd	0.08			0.003		

Figure 5. 128-Pin PQFP – Plastic Quad Flat Pack